

Blok Tip Santrifüj Pompa



Kullanım Alanları

- Su temini
- Yağmurlama-tarım
- Havalandırma
- Sıcak su
- Deniz suyu
- Az kirli sular
- Yağlar
- Yangın söndürme
- Isıtma
- İçme suyu
- Soğutma suyu
- Havuz suyu
- Kondens suyu
- Muhtelif endüstriyel akışkanlar

İşletme Bilgileri

Debi	: 200 m ³ /h'e kadar.
Basma Yüksekliği	: 90 m'ye kadar.
Pompa Çıkış Ağız	: 32-80 mm
Çalışma Basıncı	: 10 bar'a kadar.
Çalışma Sıcaklığı	: -30°C ile +140°C arası

Dizayn

Yatay salyangoz gövdeli, sondan emişli, tek kademeli, direkt akuple blok tip santrifüj pompa. Dizaynı optimize edilmiş çark ile yüksek verimlilik ve düşük enerji sarfiyatı sağlanmıştır.

Mil Sızdırmazlığı

EN 12756'ya uygun mekanik salmastra.

Tanımlama

Tipi	BETABLOC	65	-	250	G	16
Basma ağız DN						
Nominal çark çapı-mm						
Malzeme kodu (G,M,B,S,C)						
Salmastra tipi:						
						16 - Standart max. 140°C su için mekanik salmastra

Motor

Üç faz sincap kafesli asenkron motor.	
2,2 kw'a kadar	: 220-240V / 380-420V
3 kw ve üzeri	: 380-420V / 660-725V
Dizayn	: IM V15
Koruma sınıfı	: IP54 veya IP55
İzolasyon sınıfı	: F (opsiyonel olarak 3 termistörlü)
Çalışma modu	: Sürekli S1

Kaplin Koruyucu

EN 294'e uygun kaplin koruyucu.

Seçim Eğrileri
n=1450 d/dak.

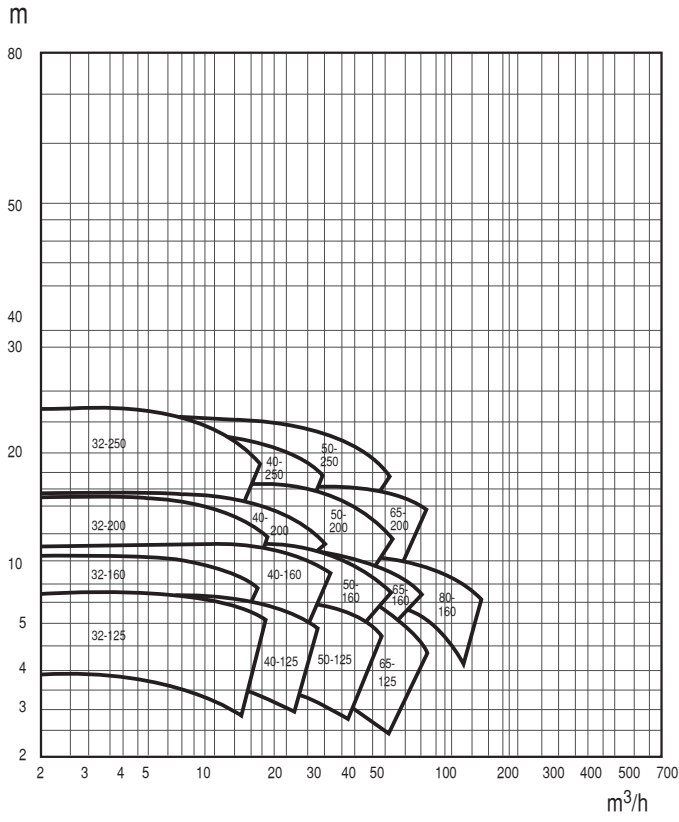

n=2900 d/dak.

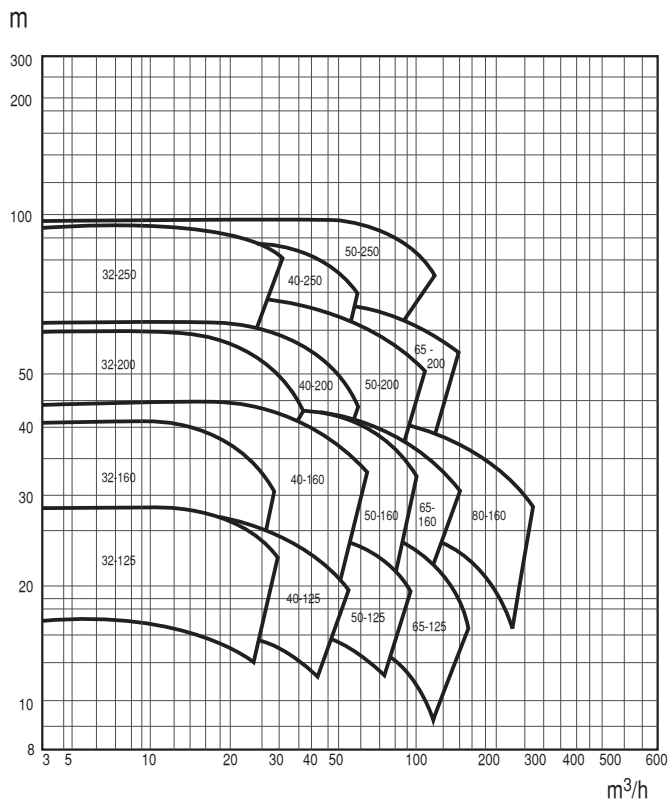

Malzeme Kombinasyonları

	BETABLOC G	BETABLOC M	BETABLOC B
Gövde	JL 1040 (Gri dökme demir)	JL 1040 (Gri dökme demir)	CC 480 K-GS (Bronz)
Baskı kapağı	JL 1040 (Gri dökme demir)	JL 1040 (Gri dökme demir)	CC 480 K-GS (Bronz)
Çark	JL 1040 (Gri dökme demir)	CC 480 K-GS (Bronz)	CC 480 K-GS (Bronz)
Mil	ST 70 (Karbon çeliği)	ST 70 (Karbon çeliği)	1.4401 (P.Çelik)
Yatak konsülü	JL 1040 (Gri dökme demir)	JL 1040 (Gri dökme demir)	JL 1040 (Gri dökme demir)

	BETABLOC S	BETABLOC C
Gövde	JS 1025 (Küresel grafitli dökme demir)	1.4401 (P.Çelik)
Baskı kapağı	JS 1025 (Küresel grafitli dökme demir)	1.4401 (P.Çelik)
Çark	JL 1040 (Gri dökme demir)	1.4401 (P.Çelik)
Mil	ST 70 (Karbon çeliği)	1.4401 (P.Çelik)
Yatak konsülü	JL 1040 (Gri dökme demir)	JL 1040 (Gri dökme demir)

Betabloc'un Üstün Özellikleri

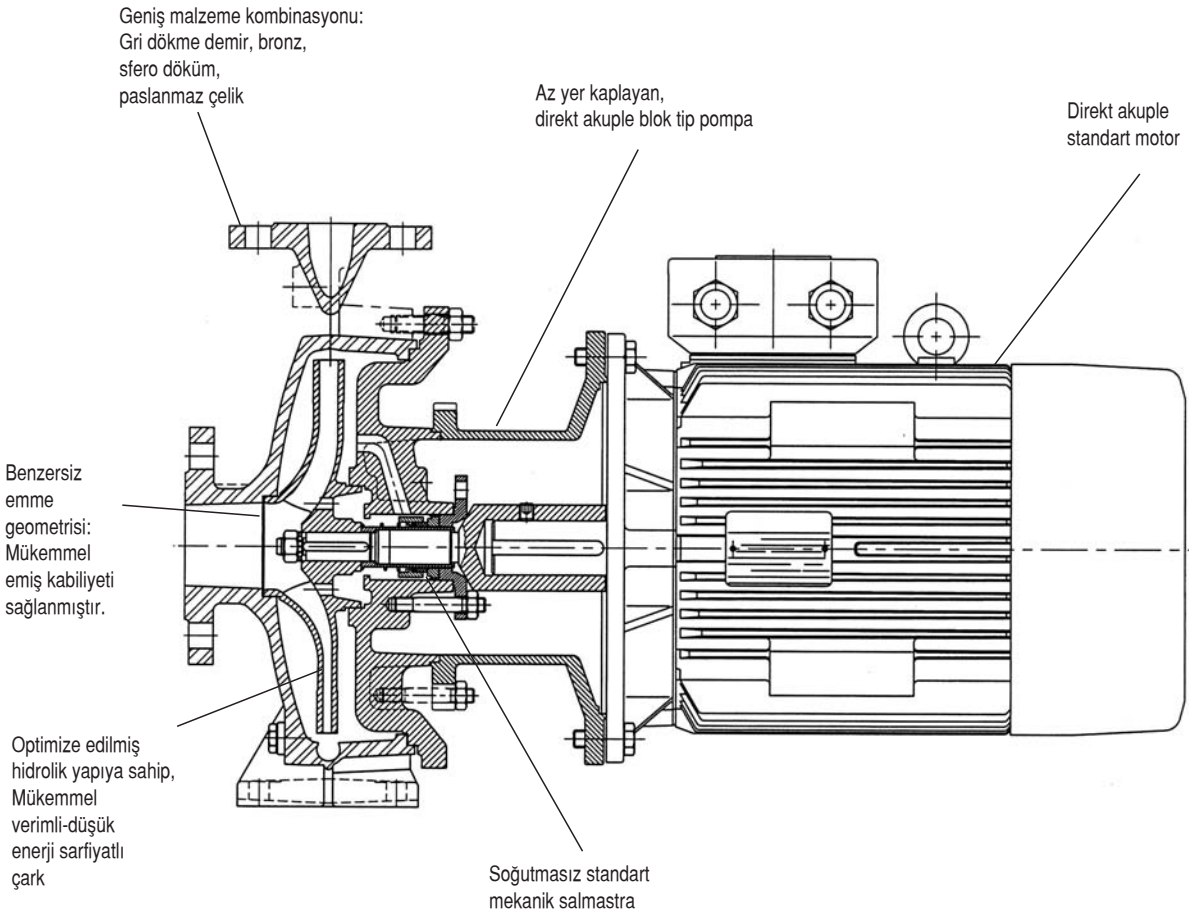

SIVI	Çalışma Limitleri	MALZEME Gövde/Çark				
		JL 1040/JL 1040	JL 1040/ CC 480 K-GS	CC 480 K-GS/ CC 480 K-GS	JS 1025/JL 1040	1.4401 / 1.4401 (P.Çelik)
SU ÇEŞİTLERİ 1)		G	M	B	S	C
Hafif tuzlu, acı su	$t \leq 25^{\circ}\text{C}$			☒		
Kondens suyu ²⁾	$t \leq 120^{\circ}\text{C}$	X				
Soğutma suyu (antifriz içermeyen)	$t \leq 60^{\circ}\text{C}$	X				
Soğutma suyu PH $\geq 7,5$ (antifrizli) ⁴⁾	$t \geq 30^{\circ}\text{C}, t \leq 110^{\circ}\text{C}$	X				
Baraj suyu	$t \leq 60^{\circ}\text{C}$		X			
İçme suyu	$t \leq 60^{\circ}\text{C}$		X			
Yangın söndürme suyu	$t \leq 35^{\circ}\text{C}$		X	X	X	
Tam tuzu alınmış su ²⁾	$t \leq 120^{\circ}\text{C}$					X
Isıtma suyu ²⁾	$t \leq 120^{\circ}\text{C}$	X				
Isıtma suyu ²⁾	$t \leq 140^{\circ}\text{C}$	X				
Isıtma suyu ³⁾	$t \leq 110^{\circ}\text{C}$	X	X	X	X	
Kısmen tuzu alınmış su	$t \leq 120^{\circ}\text{C}$					X
Saf su ⁵⁾	$t \leq 60^{\circ}\text{C}$	X				
Ham su	$t \leq 60^{\circ}\text{C}$	X	X			
Deniz suyu	$t \leq 25^{\circ}\text{C}$			X		
Çok az kirli su	$t \leq 60^{\circ}\text{C}$	X				
Yüzme havuzu suyu (tatlı su)	$t \leq 60^{\circ}\text{C}$	X	X			
Yüzme havuzu suyu (deniz suyu) ^{1) 4)}	$t \leq 40^{\circ}\text{C}$			X		
Soğutucular ve soğutma tuz çözeltilisi						
Soğutma tuz çözeltilisi, inorganik PH>7,5	$t \geq -30^{\circ}\text{C}, t \leq 25^{\circ}\text{C}$	X				
Antifrizli su, PH>7,5	$t \geq -30^{\circ}\text{C}, t \leq 110^{\circ}\text{C}$	X	X	X		
Yakıtlar ve Yağlar						
Dizel yakıtı, fuel-oil EL	$t \leq 60^{\circ}\text{C}$				X	
Delik açma işlemleri için yağ emülsiyonları	$t \leq 60^{\circ}\text{C}$	X	X	X		
Yağlama yağı, türbin yağı (SDF yağları için uygun değil)	$t \leq 80^{\circ}\text{C}$				X	
Yağ ve su karışımları	$t \leq 60^{\circ}\text{C}$	X				

Çalışma Limitleri ve liste dışındaki sıvılar için KSB Ofislerine danışınız.

1) Su analizi için genel kriter: PH > 6,5; Cl < 150 mg/kg, Cl < 0,6 mg/kg.
Bronz parçalar içeren pompalar için kriter: Amonyak (NH) < 5 mg/kg,
Hidrojen sülfat'tan (H S); arındırılmış olmalıdır. Eğer limitler aşıyor ise
lütfen KSB Ofislerine başvurunuz.

2) 25°C'deki iletkenlik <250 uS/cm. SiO (Silikat) içeriği <10 mg/l

3) 25°C'deki iletkenlik : 100 ile 800 uS/cm

4) % 20 ile % 50 arasında

5) Ultra saf su değil! 25°C'deki iletkenlik < 800 uS/cm

Beta 32-125

2900 d/dak

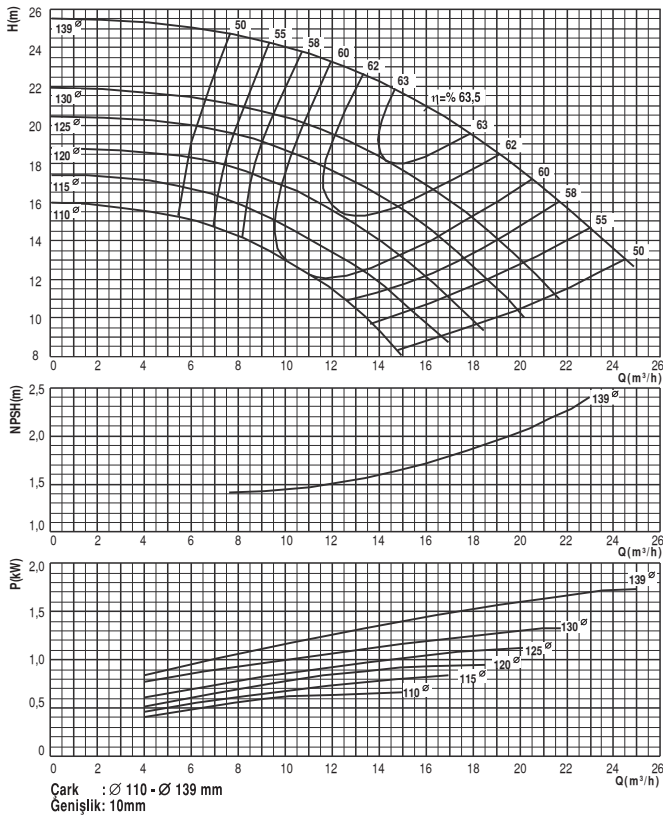

Beta 32-160

2900 d/dak

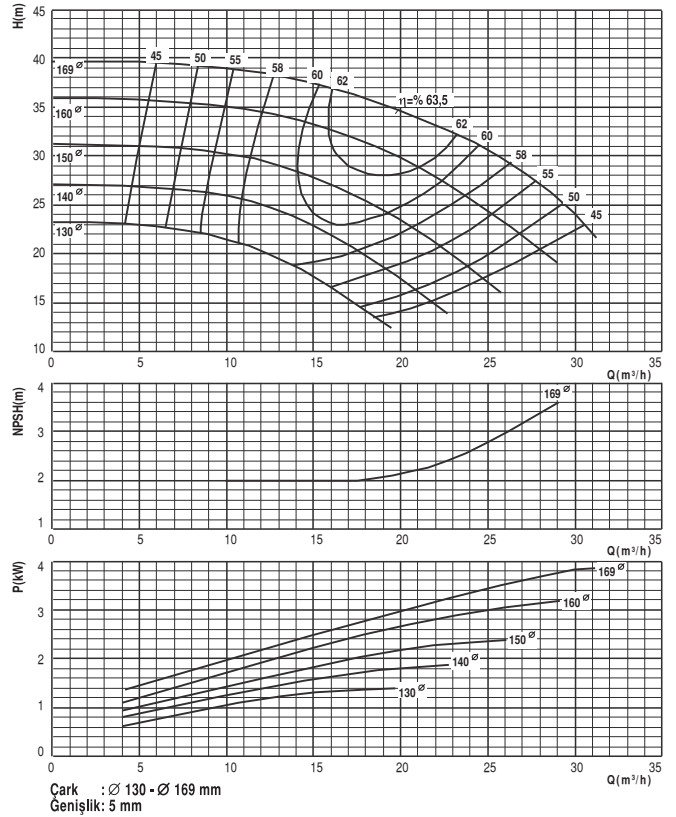

Beta 32-200

2900 d/dak

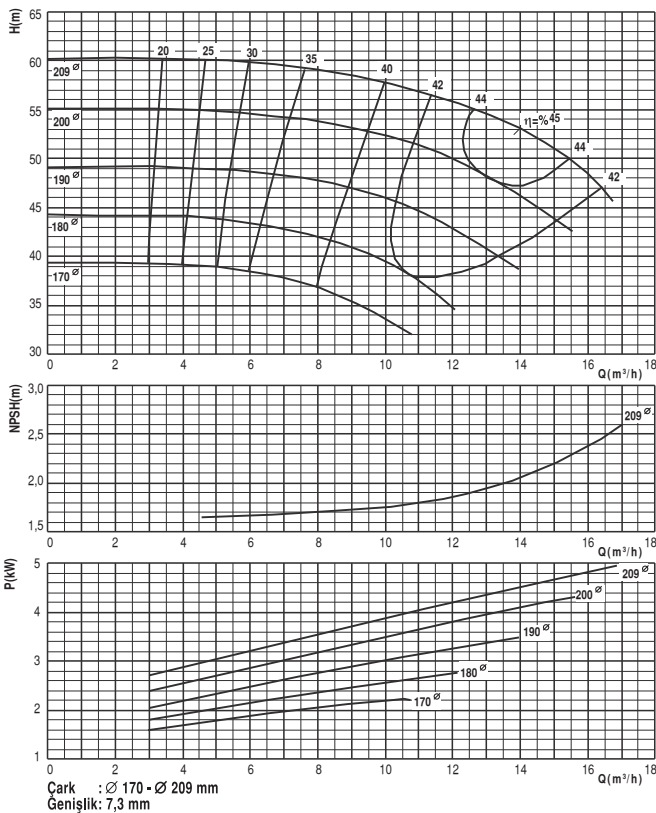

Beta 32-250

2900 d/dak

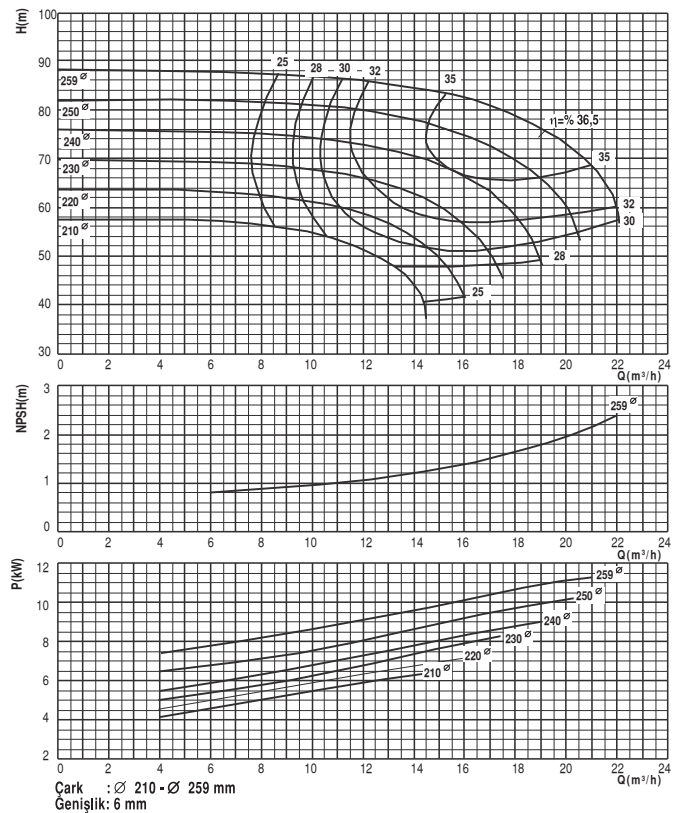

Beta 40-125

2900 d/dak

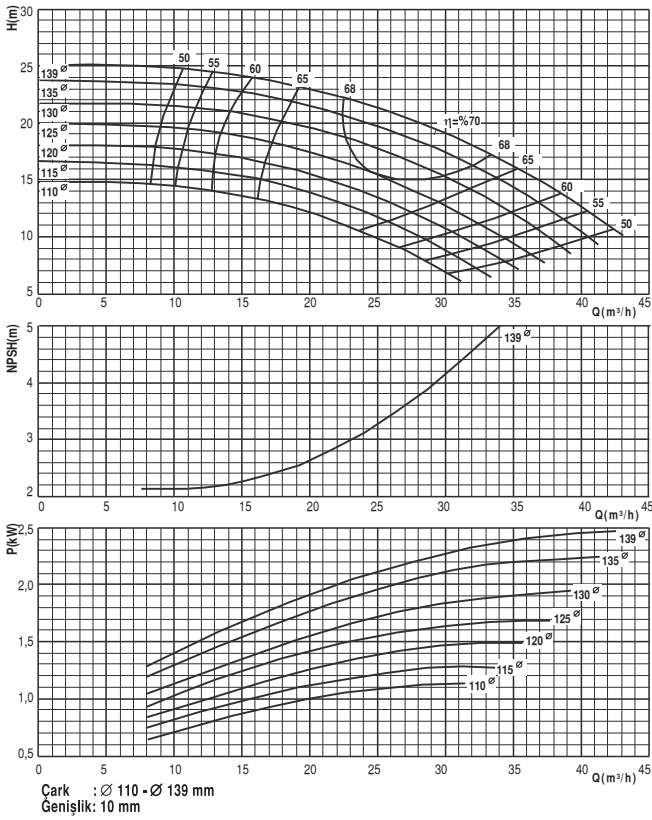

Beta 40-160

2900 d/dak

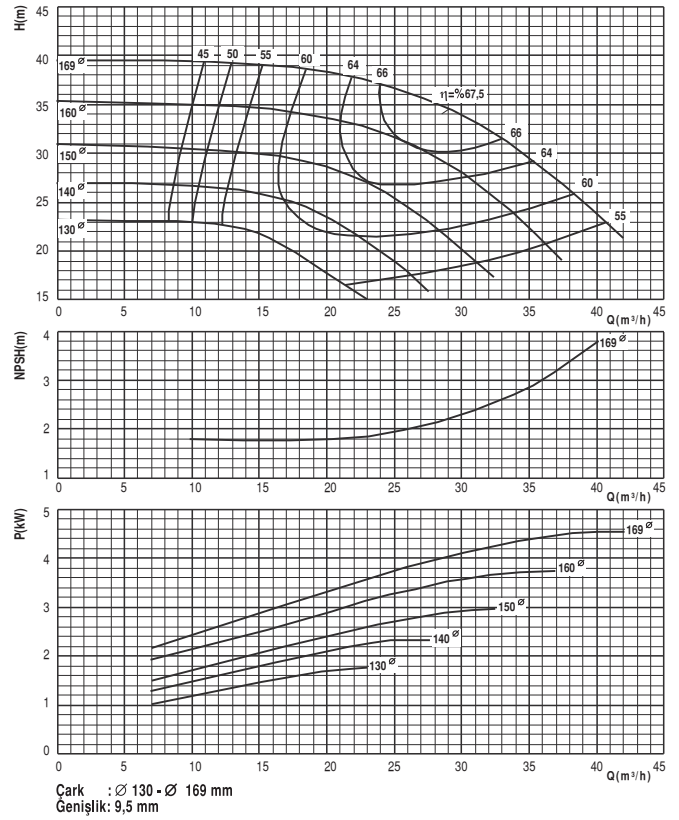

Beta 40-200

2900 d/dak

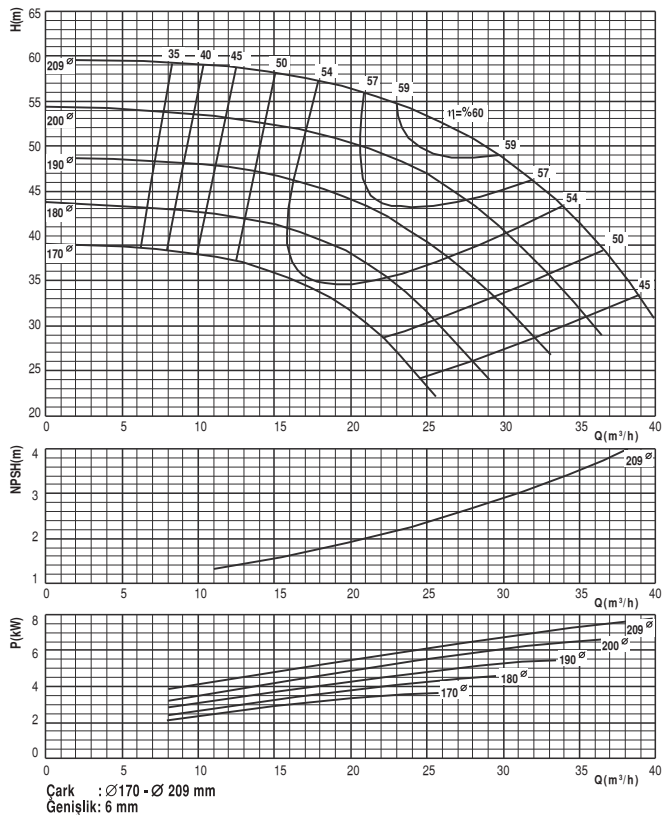

Beta 40-250

2900 d/dak

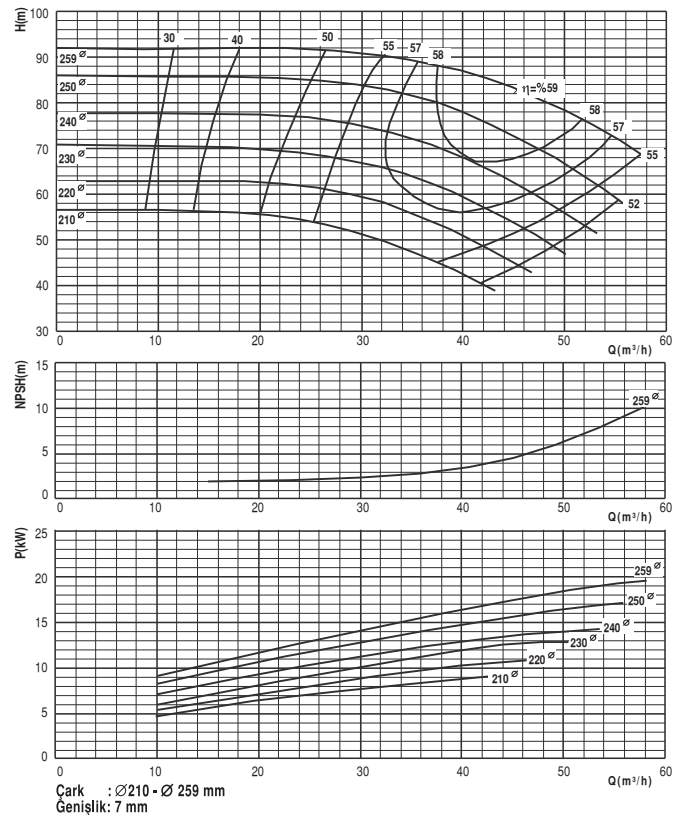

Beta 50-125

2900 d/dak

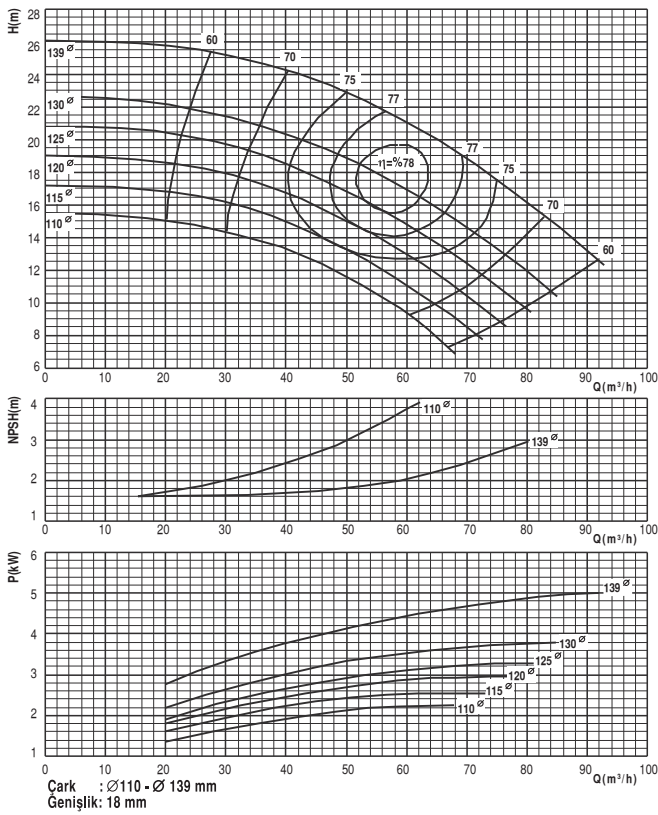

Beta 50-160

2900 d/dak

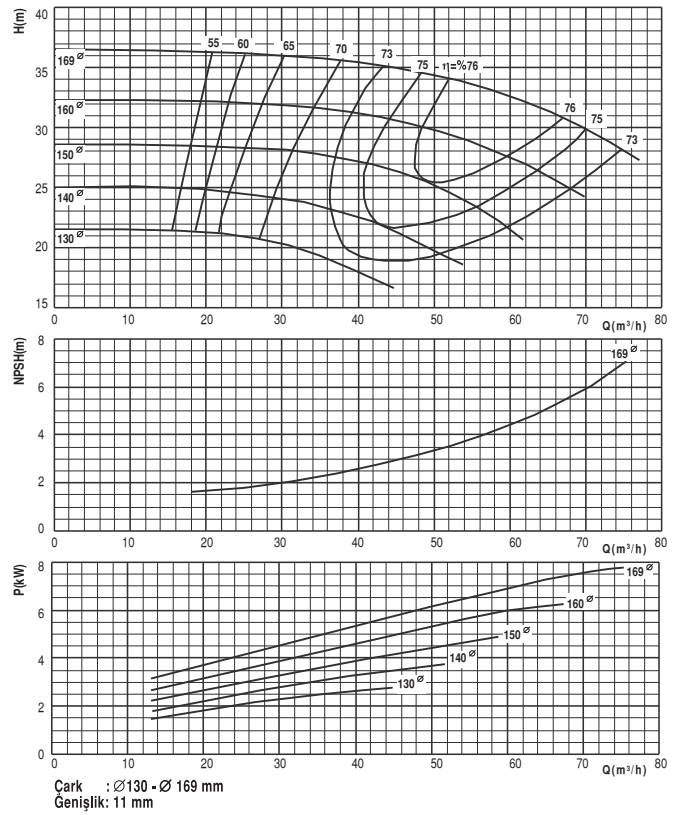

Beta 50-200

2900 d/dak

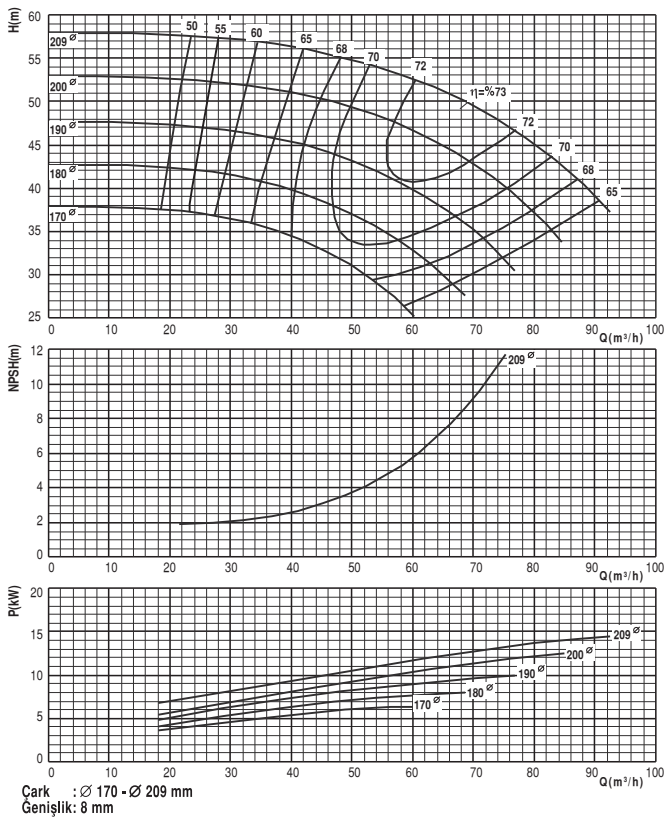

Beta 50-250

2900 d/dak

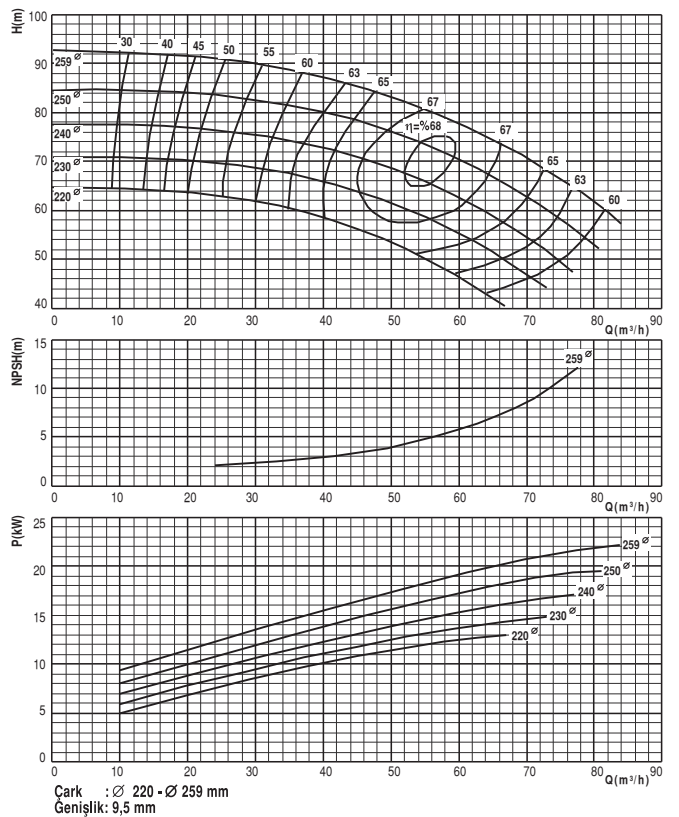

Beta 65-125

2900 d/dak

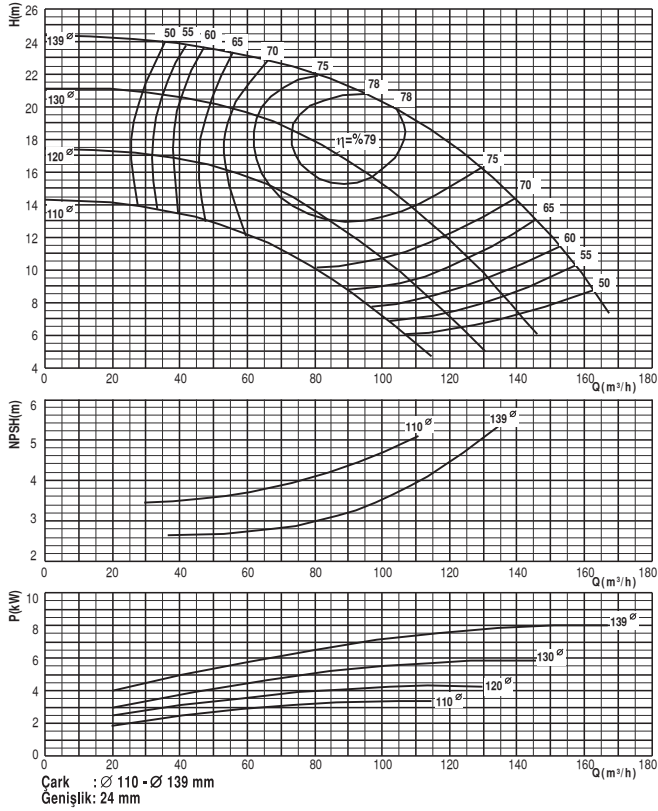

Beta 65-160

2900 d/dak

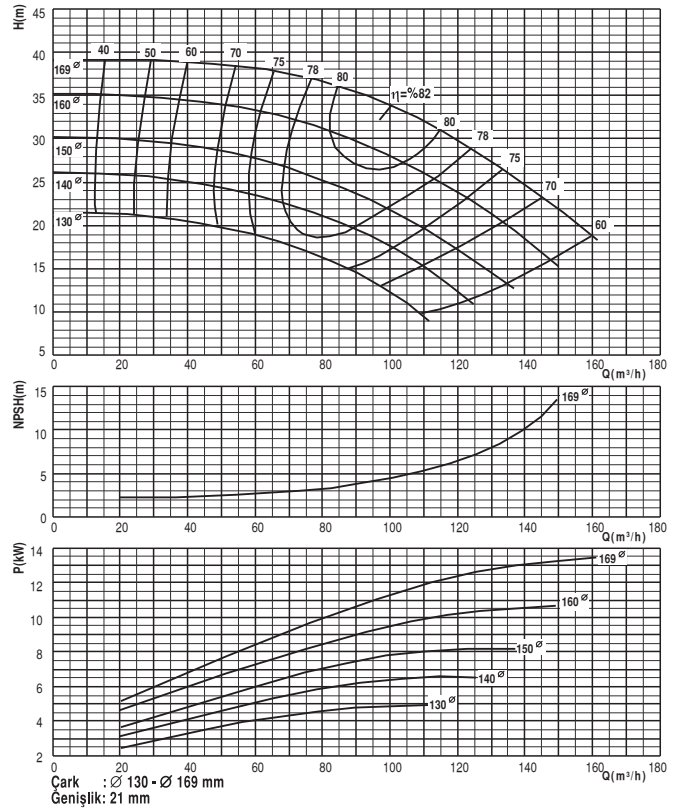

Beta 65-200

2900 d/dak

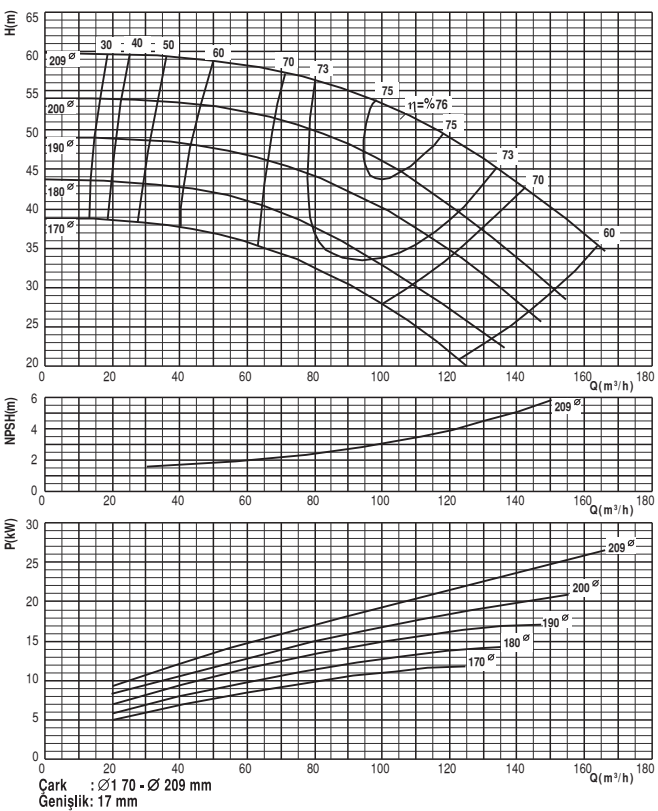

Beta 80-160

2900 d/dak

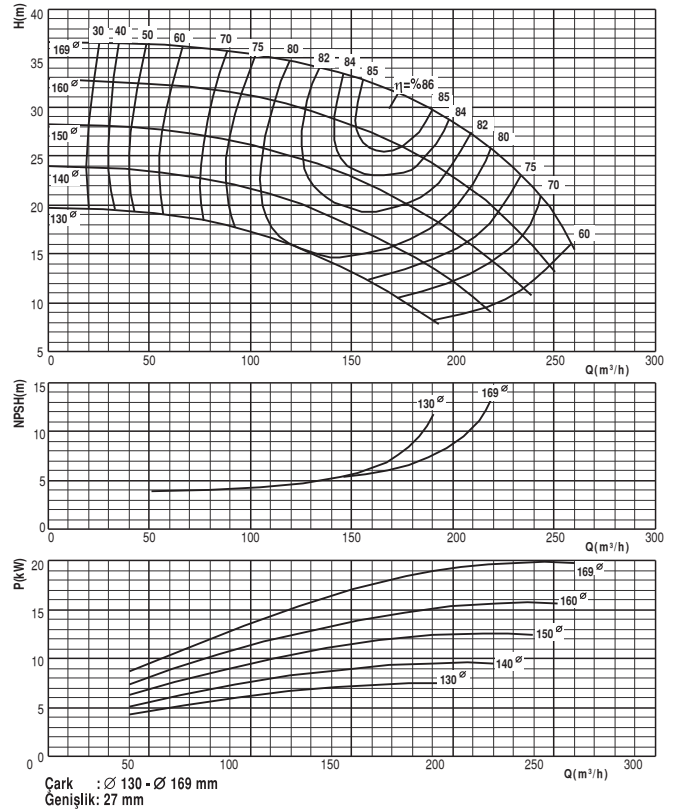

Beta 32-125

1450 d/dak

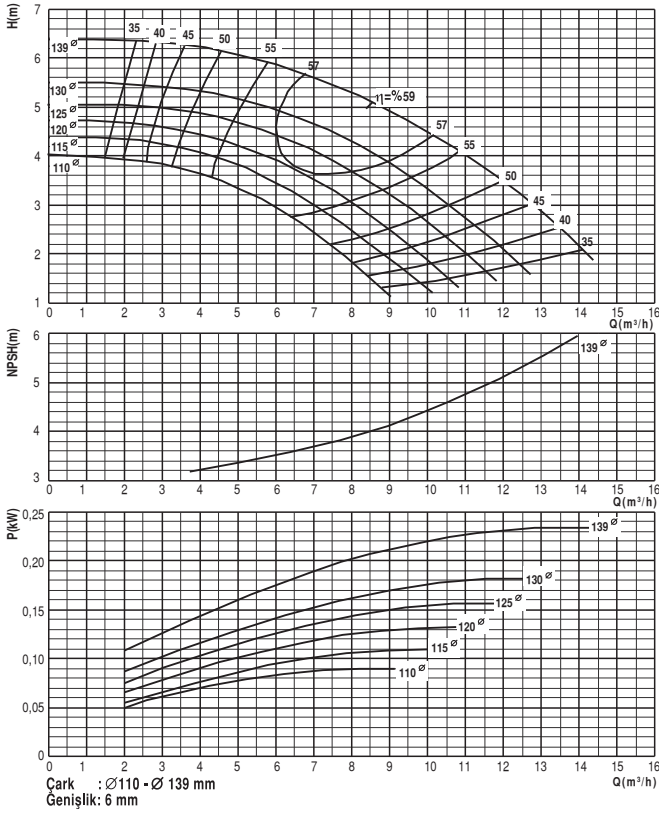

Beta 32-160

1450 d/dak

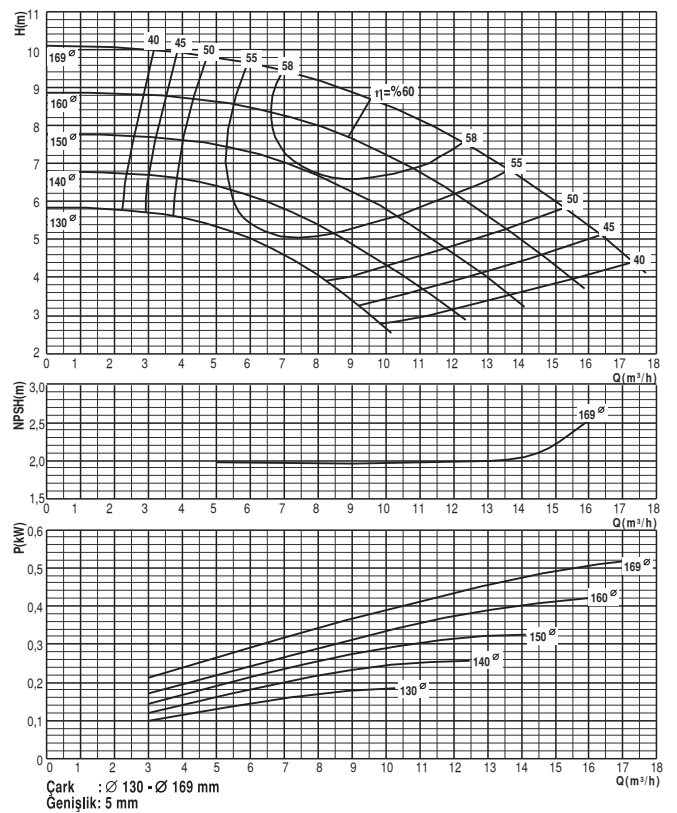

Beta 32-200

1450 d/dak

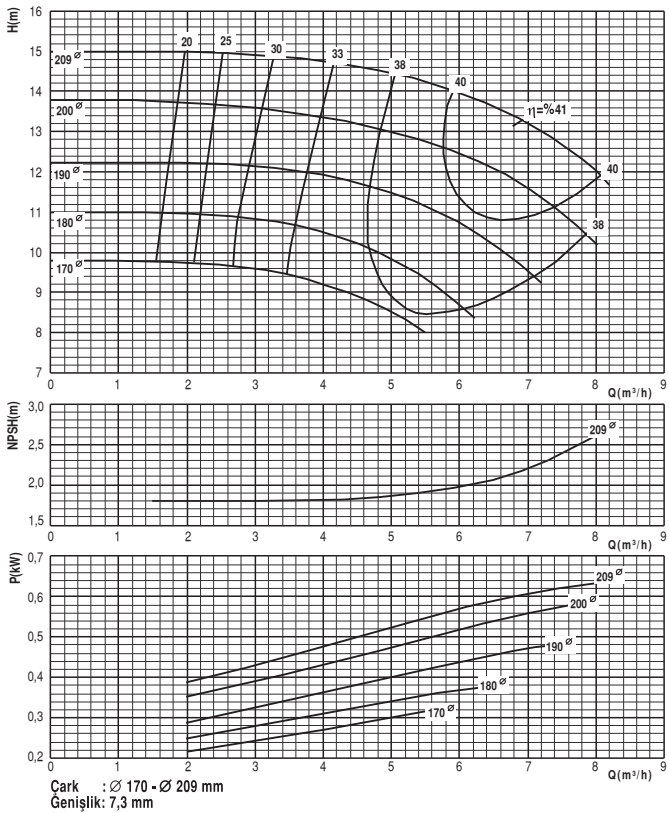

Beta 32-250

1450 d/dak

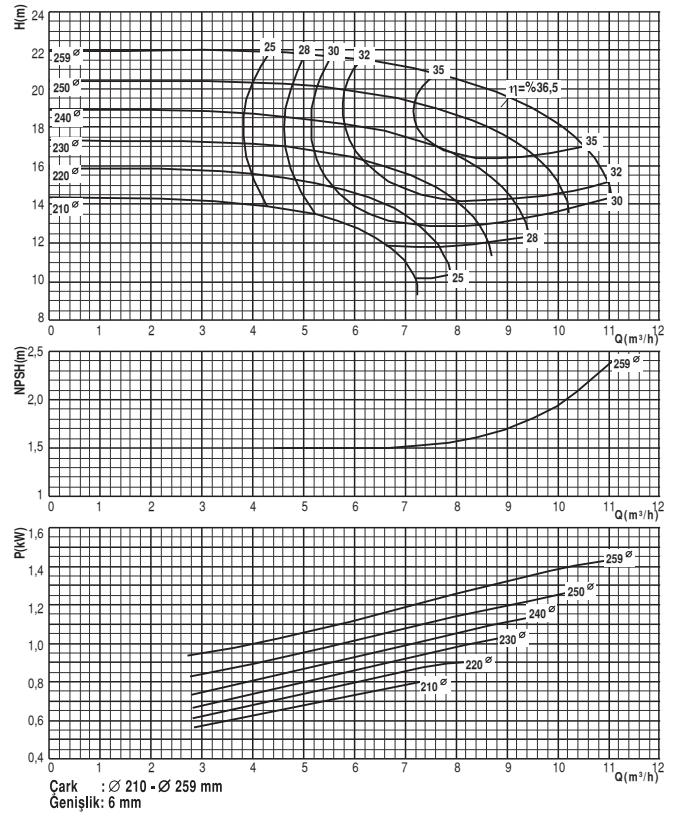

Beta 40-125

1450 d/dak

Beta 40-160

1450 d/dak

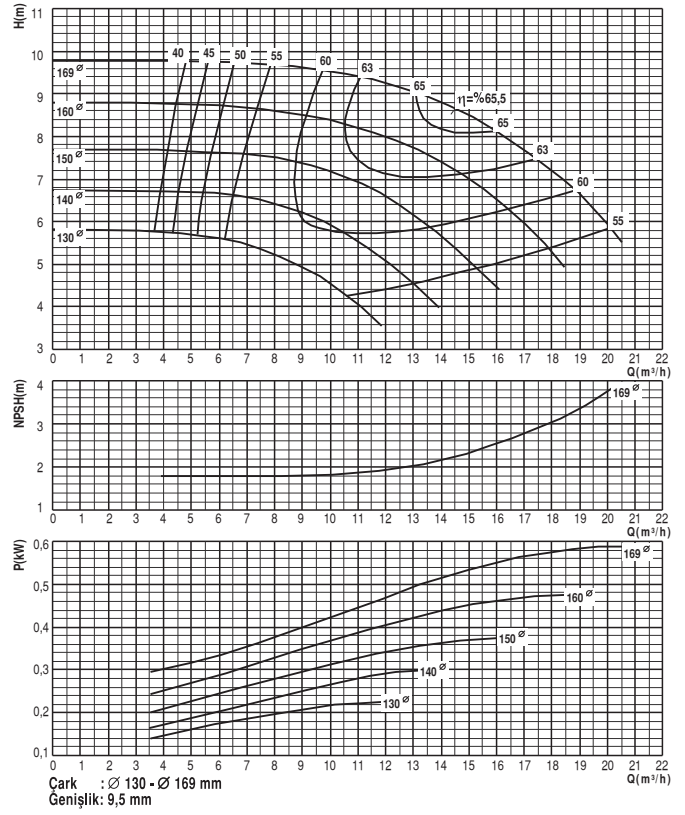
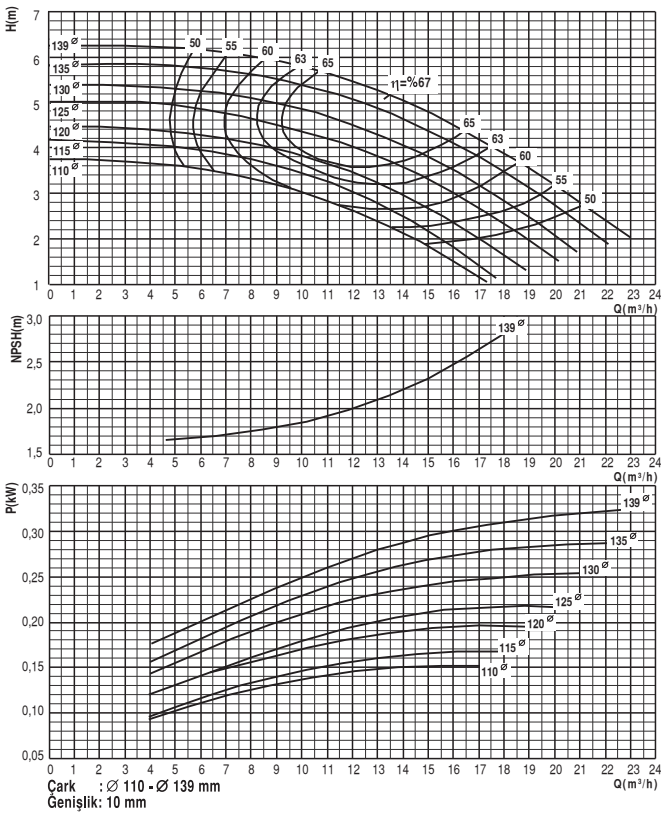

Beta 40-200

1450 d/dak

Beta 40-250

1450 d/dak

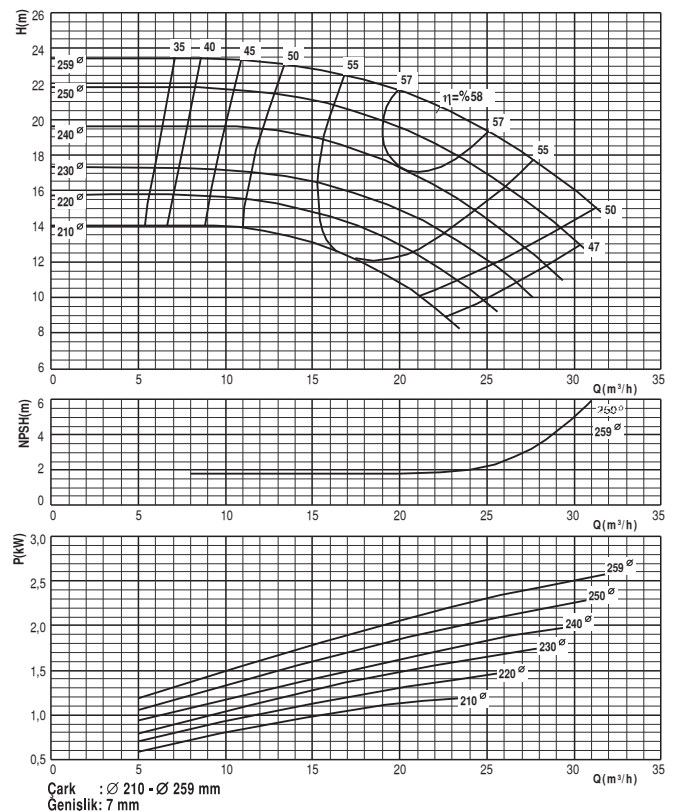
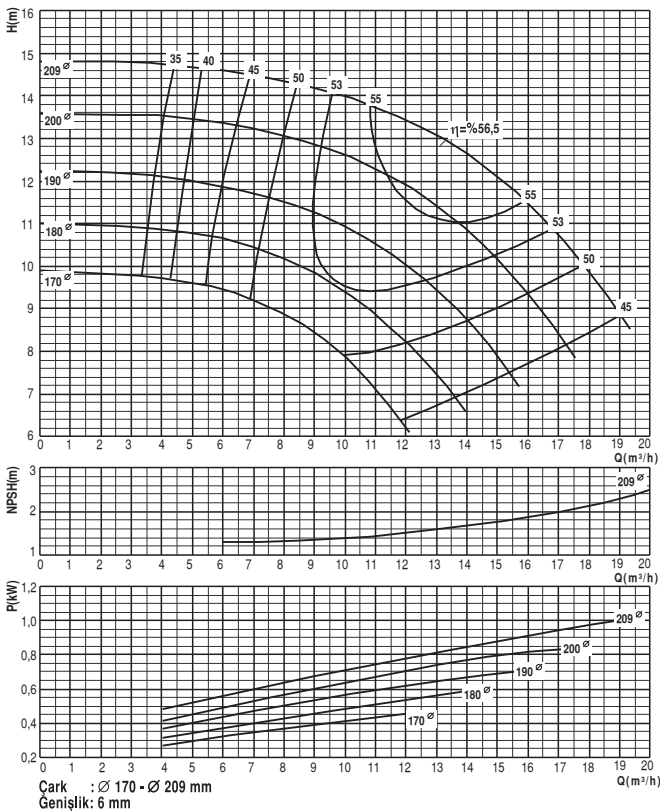

Beta 50-125

1450 d/dak

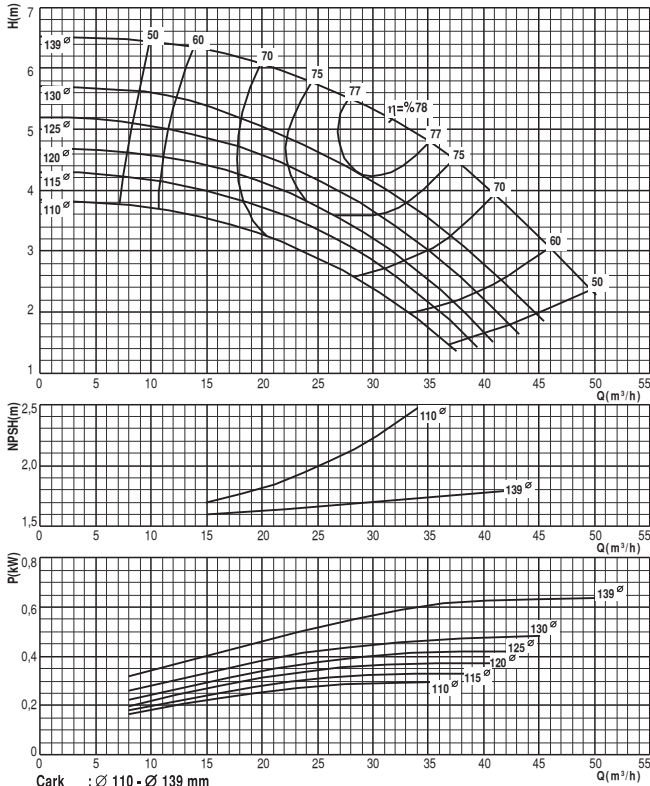

Çark : Ø 110 - Ø 139 mm
Genişlik: 18 mm

Beta 50-160

1450 d/dak

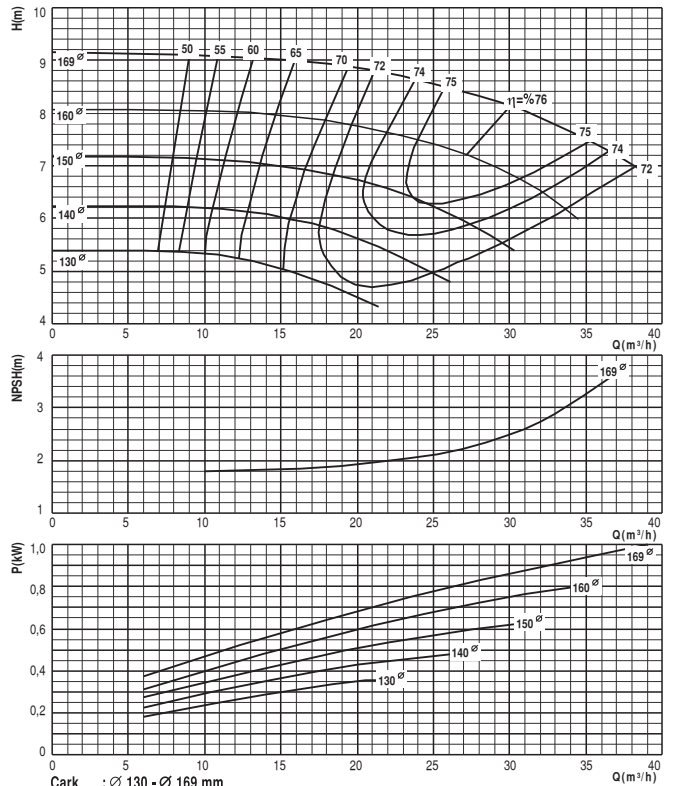

Çark : Ø 130 - Ø 169 mm
Genişlik: 11 mm

Beta 50-200

1450 d/dak

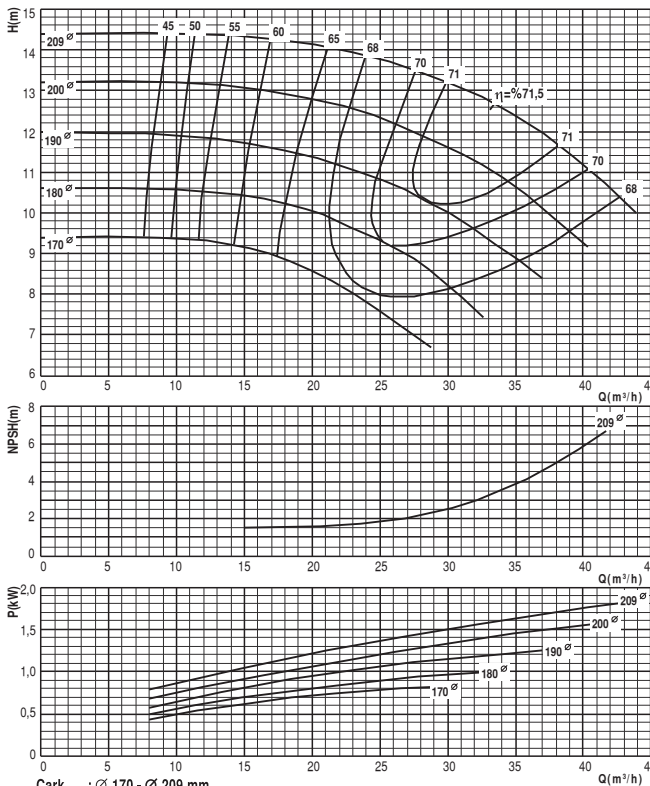

Çark : Ø 170 - Ø 209 mm
Genişlik: 8 mm

Beta 50-250

1450 d/dak

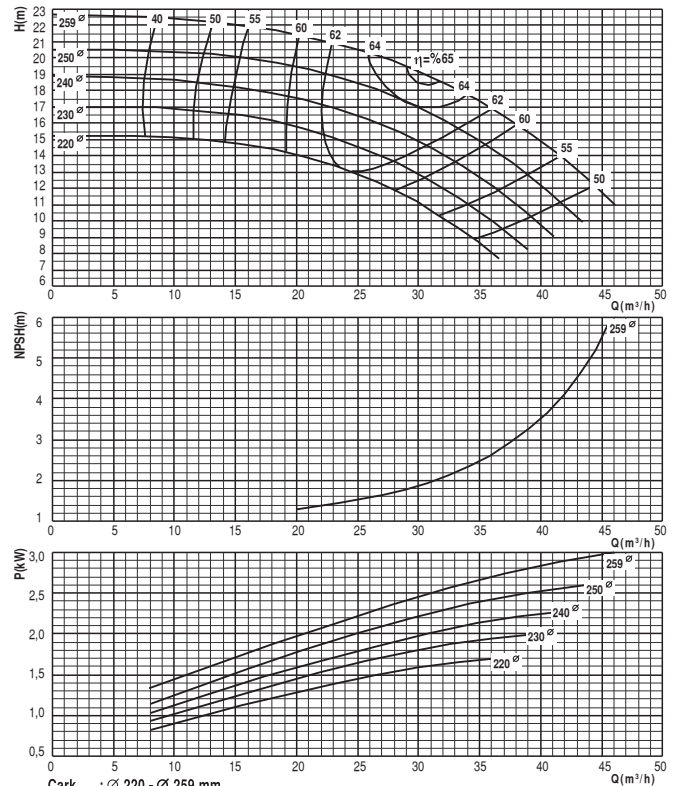

Çark : Ø 220 - Ø 259 mm
Genişlik: 9,5 mm

Beta 65-125

1450 d/dak

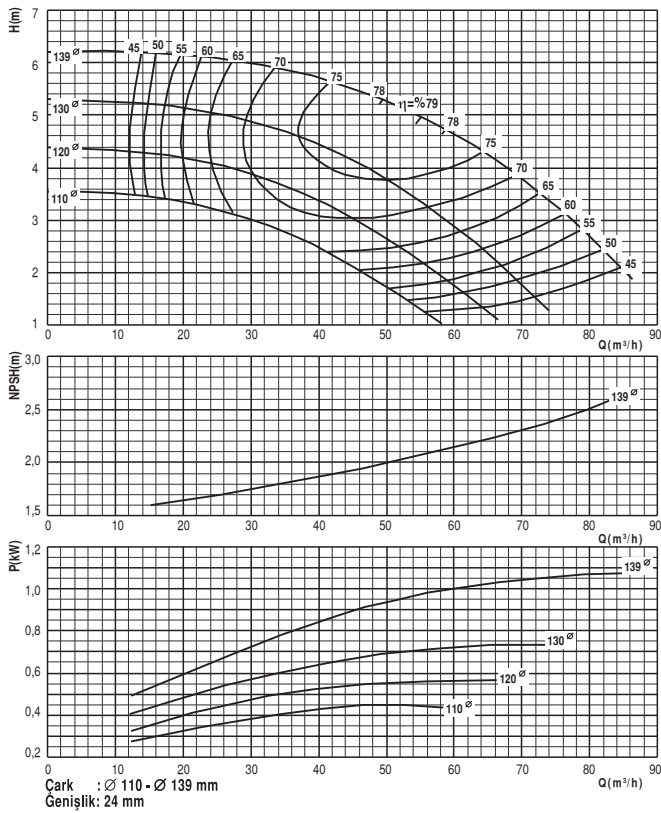

Beta 65-160

1450 d/dak

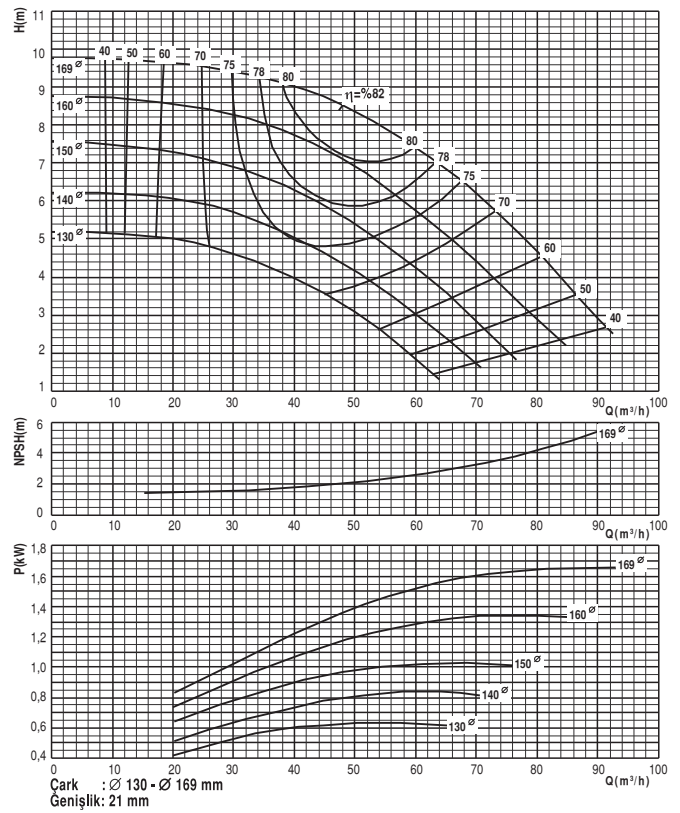

Beta 65-200

1450 d/dak

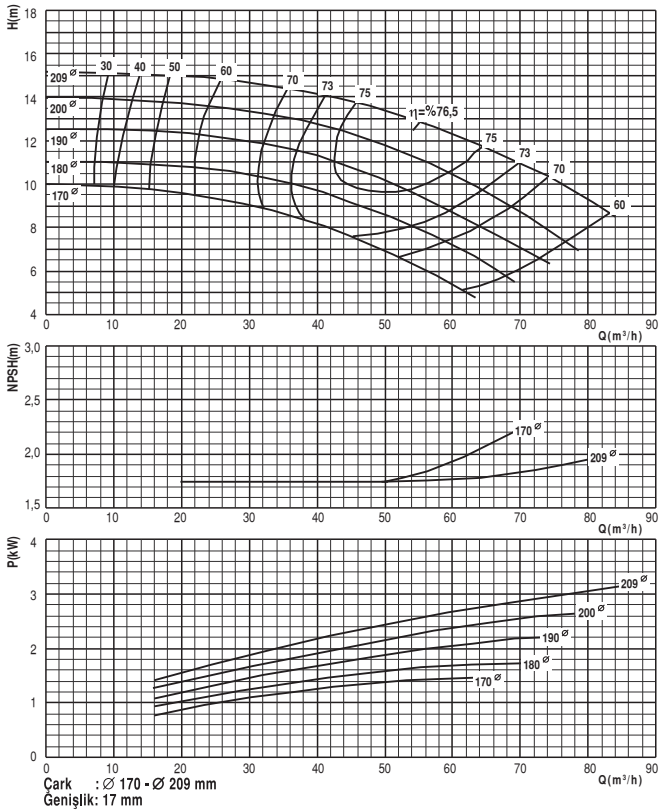

Beta 80 -160

1450 d/dak

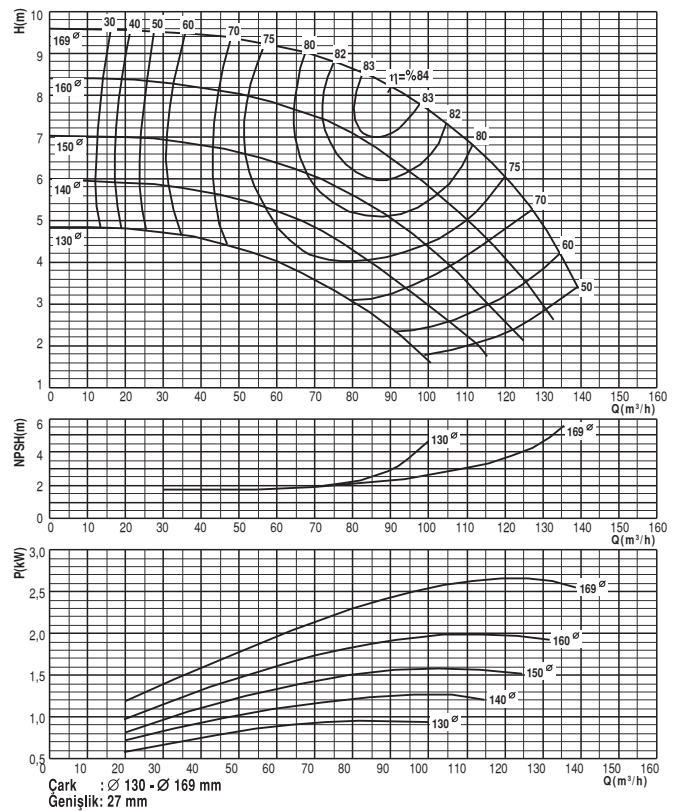

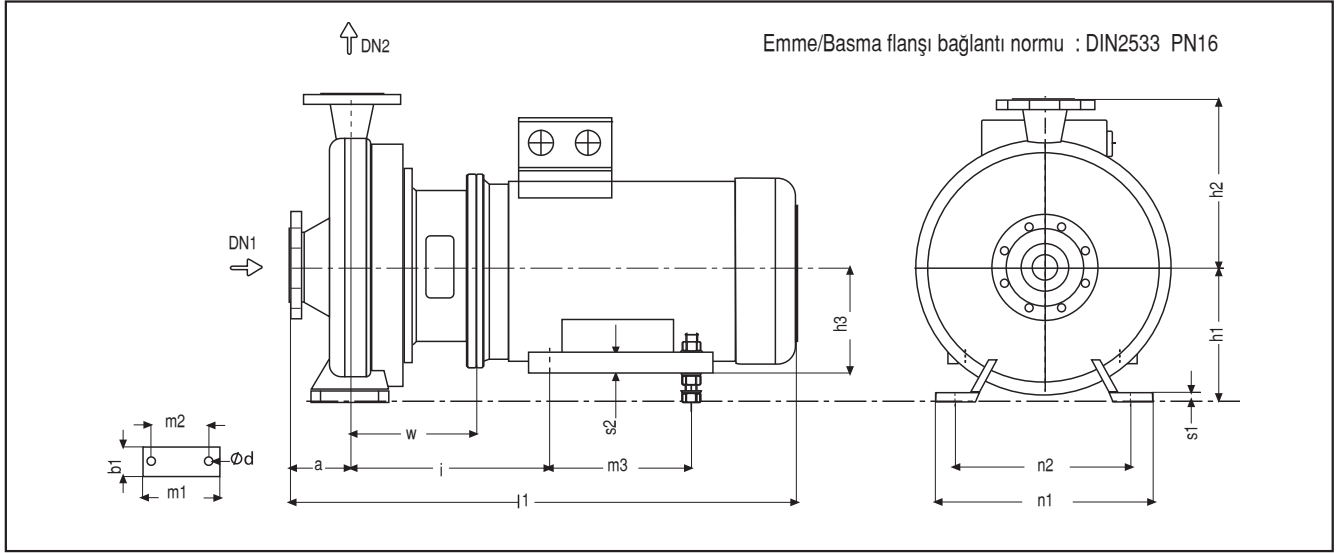
BETABLOC 32-125 - 40-160

Betabloc		2900 1450		konsol tipi	DN1	DN2	a	w	i	h1	h2	l1	h3	s1	m1	m2	s2	n1	n2	Ød	W(kg)
		d/dak	kW																		
32-125	024		0,25	605	50	32	80	155	200	112	140	445	71	15	100	70	7	190	140	14	28
	072	0,75		606	50	32	80	155	205	112	140	468	80	15	100	70	8	190	140	14	33
	112	1,1		606	50	32	80	155	205	112	140	468	80	15	100	70	8	190	140	14	35
	152	1,5		606	50	32	80	155	211	112	140	516	90	15	100	70	10	190	140	14	37
	222	2,2		606	50	32	80	155	211	112	140	516	90	15	100	70	10	190	140	14	40
32-160	024		0,25	605	50	32	80	136	181	132	160	426	71	15	100	70	7	240	190	14	31
	034		0,37	605	50	32	80	136	181	132	160	426	71	15	100	70	7	240	190	14	32
	054		0,55	606	50	32	80	156	186	132	160	469	80	15	100	70	8	240	190	14	35
	152	1,5		606	50	32	80	156	212	132	160	517	90	15	100	70	10	240	190	14	39
	222	2,2		606	50	32	80	156	212	132	160	517	90	15	100	70	10	240	190	14	42
	302	3		607	50	32	80	170	233	132	160	562	100	15	100	70	12	240	190	14	50
	402	4		607	50	32	80	170	240	132	160	583	112	15	100	70	12	240	190	14	57
32-200	034		0,37	605	50	32	80	136	181	160	180	426	71	18	100	70	7	240	190	14	40
	054		0,55	606	50	32	80	156	206	160	180	469	80	18	100	70	8	240	190	14	43
	074		0,75	606	50	32	80	156	206	160	180	469	80	18	100	70	8	240	190	14	44
	222	2,2		606	50	32	80	156	212	160	180	517	90	18	100	70	10	240	190	14	50
	302	3		607	50	32	80	170	233	160	180	562	100	18	100	70	12	240	190	14	58
	402	4		607	50	32	80	170	240	160	180	583	112	18	100	70	12	240	190	14	65
	552	5,5		608	50	32	80	193	282	160	180	645	132	18	100	70	15	240	190	14	77
32-250	114		1,1	606	50	32	100	156	206	180	225	489	90	18	125	95	10	320	250	14	61
	154		1,5	606	50	32	100	156	212	180	225	537	90	18	125	95	10	320	250	14	64
	752	7,5		608	50	32	100	193	282	180	225	665	132	18	125	95	15	320	250	14	100
	1102	11		609	50	32	100	226	334	180	225	801	160	18	125	95	18	320	250	14	126
40-125	024		0,25	605	65	40	80	136	181	112	140	426	71	15	100	70	7	210	160	14	31
	034		0,37	605	65	40	80	136	181	112	140	426	71	15	100	70	7	210	160	14	32
	152	1,5		606	65	40	80	156	212	112	140	517	90	15	100	70	10	210	160	14	39
	222	2,2		606	65	40	80	156	212	112	140	517	90	15	100	70	10	210	160	14	42
	302	3		607	65	40	80	170	233	112	140	562	100	15	100	70	12	210	160	14	50
40-160	024		0,25	605	65	40	80	136	181	132	160	426	71	15	100	70	7	240	190	14	34
	034		0,37	605	65	40	80	136	181	132	160	426	71	15	100	70	7	240	190	14	35
	054		0,55	606	65	40	80	156	206	132	160	469	80	15	100	70	8	240	190	14	38
	074		0,75	606	65	40	80	156	206	132	160	469	80	15	100	70	8	240	190	14	39
	222	2,2		606	65	40	80	156	212	132	160	517	90	15	100	70	10	240	190	14	45
	302	3		607	65	40	80	170	233	132	160	562	100	15	100	70	12	240	190	14	53
	402	4		607	65	40	80	170	240	132	160	583	112	15	100	70	12	240	190	14	60
	552	5,5		608	65	40	80	193	282	187	160	645	132	15	100	70	15	240	190	14	72

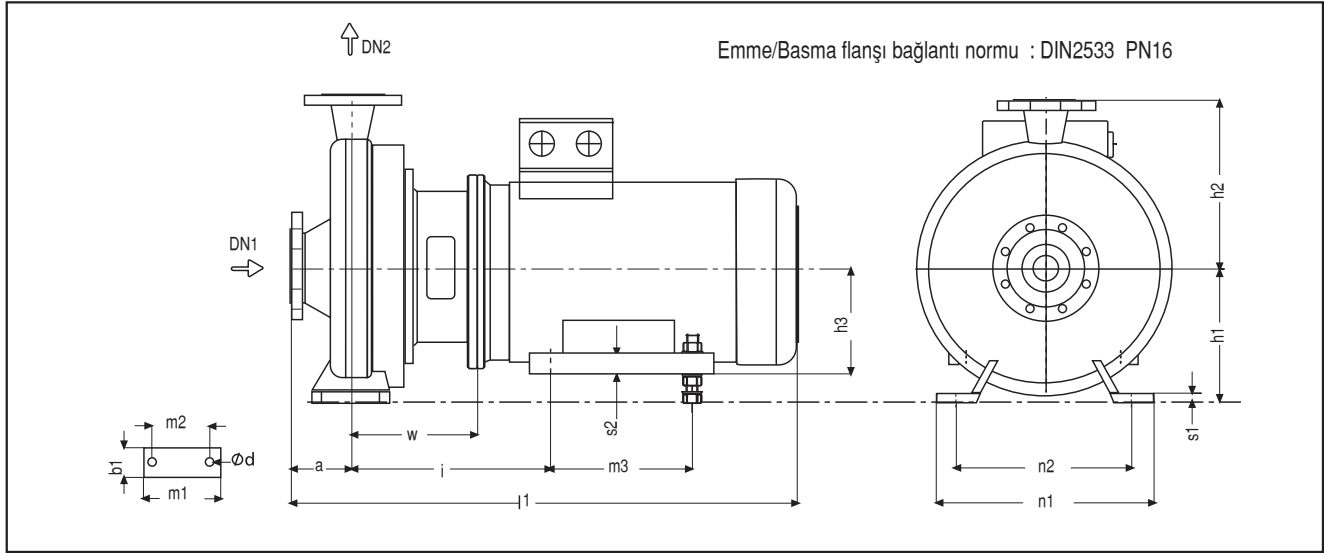
BETABLOC 40-200 - 50-125

Betabloc		2900	1450	konsol tipi	DN1	DN2	a	w	i	h1	h2	l1	h3	s1	m1	m2	s2	n1	n2	Ød	W(kg)
		d/dak	kW																		
40-200	054		0,55	606	65	40	100	156	206	160	180	489	80	18	100	70	8	265	212	14	46
	074		0,75	606	65	40	100	156	206	160	180	489	80	18	100	70	8	265	212	14	47
	114		1,1	606	65	40	100	156	206	160	180	489	90	18	100	70	10	265	212	14	50
	402	4		607	65	40	100	170	240	160	180	603	112	18	100	70	12	265	212	14	67
	552	5,5		608	65	40	100	193	282	160	180	665	132	18	100	70	15	265	212	14	80
	752	7,5		608	65	40	100	193	282	160	180	665	132	18	100	70	15	265	212	14	89
	1102	11		609	65	40	100	226	334	215	180	804	160	18	100	70	18	265	212	14	115
40-250	154		1,5	606	65	40	100	156	212	180	225	537	90	18	125	95	10	320	250	14	69
	224		2,2	607	65	40	100	170	226	180	225	551	100	18	125	95	12	320	250	14	76
	304		3	607	65	40	100	170	233	180	225	582	100	18	125	95	12	320	250	14	79
	1102	11		609	65	40	100	226	334	180	225	804	160	18	125	95	18	320	250	14	132
	1502	15		609	65	40	100	226	334	180	225	804	160	18	125	95	18	320	250	14	141
	1802	18,5		609	65	40	100	226	334	180	225	804	160	18	125	95	18	320	250	14	150
	2202	22		609	65	40	100	226	347	180	225	928	180	18	125	95	18	320	250	14	177
50-125	034		0,37	605	65	50	100	156	181	132	160	466	71	18	100	70	7	240	190	14	35
	054		0,55	605	65	50	100	156	206	132	160	466	80	18	100	70	8	240	190	14	38
	074		0,75	606	65	50	100	170	206	132	160	503	80	18	100	70	8	240	190	14	39
	302	3		607	65	50	100	170	233	132	160	582	100	18	100	70	12	240	190	14	53
	402	4		607	65	50	100	170	240	132	160	603	112	18	100	70	12	240	190	14	60
	552	5,5		608	65	50	100	193	282	187	160	665	132	18	100	70	15	240	190	14	72

Bu tablo Siemens motor ölçülerine göre oluşturulmuştur. Motor markasındaki değişiklik veya Siemens motor üreticisinin katalog ölçülerini değiştirmesi bu tablodaki ölçüleri etkileyebilir.

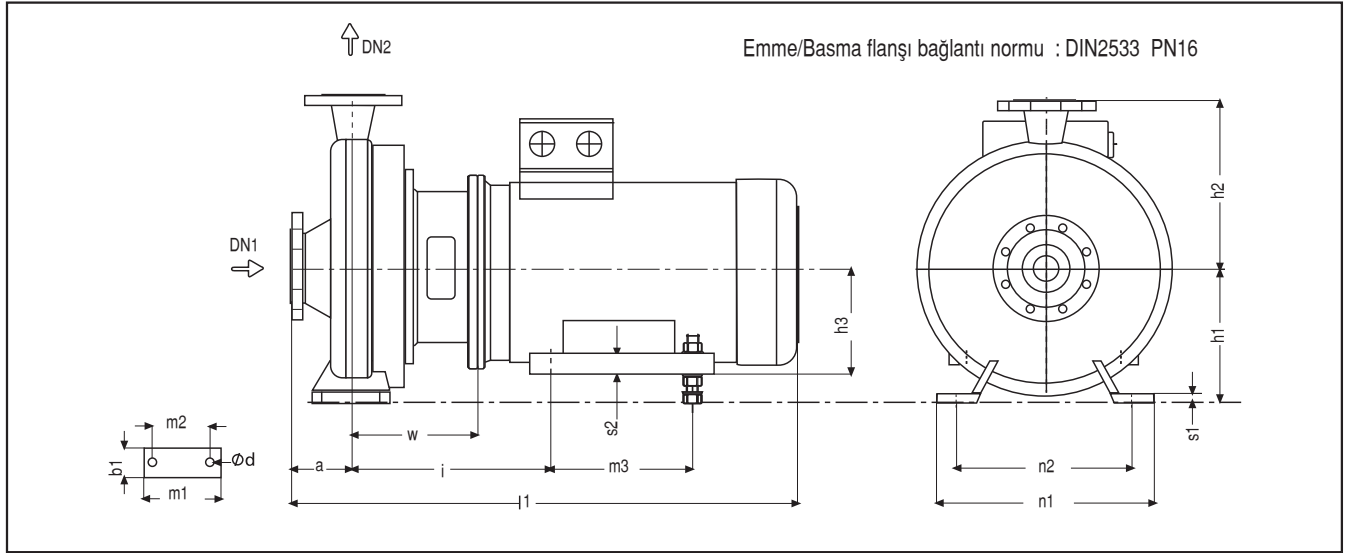
BETABLOC 50-160 - 65 -160

Betabloc		2900 1450		konsol tipi																	
		d/dak kW			DN1	DN2	a	w	i	h1	h2	l1	h3	s1	m1	m2	s2	n1	n2	Ød	W(kg)
50-160	034		0,37	605	65	50	100	136	181	160	180	446	71	18	100	70	7	265	212	14	38
	054		0,55	606	65	50	100	156	206	160	180	489	80	18	100	70	8	265	212	14	41
	074		0,75	606	65	50	100	156	206	160	180	489	80	18	100	70	8	265	212	14	42
	302	3		607	65	50	100	170	233	160	180	582	100	18	100	70	12	265	212	14	56
	402	4		607	65	50	100	170	240	160	180	603	112	18	100	70	12	265	212	14	63
	552	5,5		608	65	50	100	193	282	160	180	665	132	18	100	70	15	265	212	14	75
	752	7,5		608	65	50	100	193	282	160	180	665	132	18	100	70	15	265	212	14	85
	1102	11		609	65	50	100	226	334	215	180	804	160	18	100	70	18	265	212	14	111
50-200	114		1,1	606	65	50	100	156	206	160	200	489	90	18	100	70	10	265	212	14	53
	154		1,5	606	65	50	100	156	212	160	200	537	90	18	100	70	10	265	212	14	56
	224		2,2	607	65	50	100	170	226	160	200	551	100	18	100	70	12	265	212	14	62
	752	7,5		608	65	50	100	193	282	160	200	665	132	18	100	70	15	265	212	14	92
	1102	11		609	65	50	100	226	334	215	200	804	160	18	100	70	18	265	212	14	118
	1502	15		609	65	50	100	226	334	215	200	804	160	18	100	70	18	265	212	14	128
50-250	224		2,2	607	65	50	100	170	226	180	225	551	100	18	100	70	12	265	212	14	74
	204		3	607	65	50	100	170	233	180	225	582	100	18	100	70	12	265	212	14	77
	1502	15		609	65	50	100	226	334	180	225	804	160	18	100	70	18	265	212	14	139
	1852	18,5		609	65	50	100	226	334	180	225	804	160	18	100	70	18	265	212	14	148
	2202	22		609	65	50	100	226	347	180	225	928	180	18	100	70	18	265	212	14	175
65-125	054		0,55	606	80	65	100	156	206	160	180	489	80	18	125	95	8	280	212	14	39
	074		0,75	606	80	65	100	156	206	160	180	489	80	18	125	95	8	280	212	14	42
	402	4		607	80	65	100	170	240	160	180	603	112	18	125	95	12	280	212	14	64
	552	5,5		608	80	65	100	193	282	160	180	665	132	18	125	95	15	280	212	14	76
	752	7,5		608	80	65	100	193	282	160	180	665	132	18	125	95	15	280	212	14	86
	1102	11		609	80	65	100	226	334	220	180	804	160	18	125	95	18	280	212	14	112
65-160	114		1,1	606	80	65	100	156	206	160	200	489	90	18	125	95	10	280	212	14	50
	154		1,5	606	80	65	100	156	212	160	200	537	90	18	125	95	10	280	212	14	53
	224		2,2	607	80	65	100	170	226	160	200	551	100	18	125	95	12	280	212	14	59
	552	5,5		608	80	65	100	193	282	160	200	665	132	18	125	95	15	280	212	14	80
	752	7,5		608	80	65	100	193	282	160	200	665	132	18	125	95	15	280	212	14	89
	1102	11		609	80	65	100	226	334	220	200	804	160	18	125	95	18	280	212	14	115
	1502	15		609	80	65	100	226	334	220	200	804	160	18	125	95	18	280	212	14	125

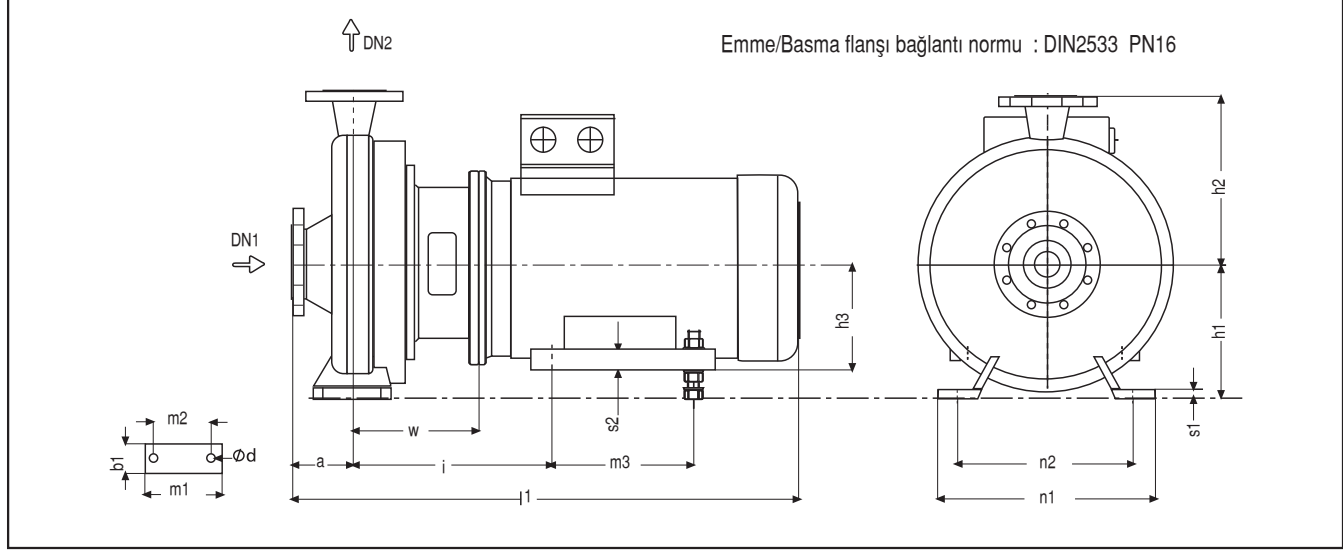
BETABLOC 65-200 - 80-160

Betabloc	2900	1450	d/dak kW	konsol tipi	DN1	DN2	a	w	i	h1	h2	l1	h3	s1	m1	m2	s2	n1	n2	Ød	W(kg)
					DN1	DN2	a	w	i	h1	h2	l1	h3	s1	m1	m2	s2	n1	n2	Ød	W(kg)
65-200	224		2,2	607	80	65	100	170	226	180	225	551	100	18	125	95	12	320	250	14	67
	204		3	607	80	65	100	170	233	180	225	582	100	18	125	95	12	320	250	14	70
	404		4	607	80	65	100	170	240	180	225	603	112	18	125	95	12	320	250	14	77
	1502	15		609	80	65	100	226	334	180	225	804	160	18	125	95	18	320	250	14	132
	1852	18,5		609	80	65	100	226	334	180	225	804	160	18	125	95	18	320	250	14	141
	2202	22		609	80	65	100	226	359	180	225	928	180	18	125	95	18	320	250	14	168
80-160	154		1,5	606	100	80	125	156	212	180	225	562	90	18	125	95	10	320	250	14	60
	224		2,2	607	100	80	125	170	226	180	225	576	100	18	125	95	12	320	250	14	67
	204		3	607	100	80	125	170	233	180	225	607	100	18	125	95	12	320	250	14	70
	404		4	607	100	80	125	170	240	180	225	628	112	18	125	95	12	320	250	14	77
	752	7,5		608	100	80	125	193	282	180	225	690	132	18	125	95	15	320	250	14	97
	1102	11		609	100	80	125	226	334	180	225	829	160	18	125	95	18	320	250	14	112
	1502	15		609	100	80	125	226	334	180	225	829	160	18	125	95	18	320	250	14	132
	1852	18,5		609	100	80	125	226	334	180	225	829	160	18	125	95	18	320	250	14	141
2202	22		609	100	80	125	226	347	180	225	953	180	18	125	95	18	320	250	14	168	

Bu tablo Siemens motor ölçülerine göre oluşturulmuştur. Motor markasındaki değişiklik veya Siemens motor üreticisinin katalog ölçülerini değiştirmesi bu tablodaki ölçüleri etkileyebilir.