

GEA VARIPUMP



GEA Hilge SIPLA

Single-stage Self-priming Centrifugal Pumps
Catalog 2020

Legal notice

Publication date: August 2020

The publication of specifications, technical data and information in written or electronic form does not release the user from the responsibility of checking for themselves all products delivered by us for suitability for the application(s) intended. These may be subject to change without prior notification. Errors and printing errors excepted – we assume no liability for the correctness of specifications given.

The general terms and conditions of delivery apply.

All rights reserved – copyright on all contents.

GEA reserves the right to make technical changes to the information in this catalog.

GEA Hilge

Niederlassung der GEA Tuchenhagen GmbH

Hilgestraße 37–47, 55294 Bodenheim, Germany

Registered Office: Büchen, Court of Registration: HRB 836 SB in Lübeck

Management Board: Franz Bürmann, Frank Prescher, Hanno Kussmann

VAT-ID: DE 812589019, Tax No.: 105/5857/1004

Introduction to GEA Flow Components.....	6
Hygienic Pumps	
Introduction to Hygienic Pumps	8
Certificates	26
GEA Hilge SIPLA Pumps	
Overview	28
Identification.....	34
Product Range.....	35
Connection Guide.....	36
Seals.....	39
Installation.....	40
Media Guide.....	42
Pump Selection Matrix.....	48
GEA Hilge SIPLA	
GEA Hilge SIPLA Adapta – on Cast Iron Foot.....	50
GEA Hilge SIPLA Adapta – on Adapta Foot.....	51
GEA Hilge SIPLA Adapta-SUPER – on Combi Foot.....	52
GEA Hilge SIPLA Bloc – on Motor Foot.....	53
GEA Hilge SIPLA Bloc-SUPER – on Combi Foot.....	54
GEA Hilge SIPLA Bloc-SUPER – on Stainless Steel Ball Feet.....	55
Performance Curves	
GEA Hilge SIPLA 3.1, 32/32 (128 × 10) – 4-pole, 50 Hz.....	56
GEA Hilge SIPLA 6.1, 40/40 (165 × 15) – 4-pole, 50 Hz.....	57
GEA Hilge SIPLA 12.1, 40/40 (165 × 15) – 4-pole, 50 Hz.....	58
GEA Hilge SIPLA 18.1, 50/50 (190 × 20) – 4-pole, 50 Hz.....	59
GEA Hilge SIPLA 28.1, 65/65 (199 × 25) – 4-pole, 50 Hz.....	60
GEA Hilge SIPLA 52.1, 65/65 (199 × 32) – 4-pole, 50 Hz.....	61
GEA Hilge SIPLA 65.1, 80/80 (236 × 35) – 4-pole, 50 Hz.....	62
GEA Hilge SIPLA 90.1, 80/80 (240 × 49) – 4-pole, 50 Hz.....	63
GEA Hilge SIPLA 3.1, 32/32 (128 × 10) – 4-pole, 60 Hz.....	64
GEA Hilge SIPLA 6.1, 40/40 (165 × 15) – 4-pole, 60 Hz.....	65
GEA Hilge SIPLA 12.1, 40/40 (165 × 15) – 4-pole, 60 Hz.....	66
GEA Hilge SIPLA 18.1, 50/50 (190 × 20) – 4-pole, 60 Hz.....	67
GEA Hilge SIPLA 28.1, 65/65 (199 × 25) – 4-pole, 60 Hz.....	68
GEA Hilge SIPLA 52.1, 65/65 (199 × 32) – 4-pole, 60 Hz.....	69
GEA Hilge SIPLA 65.1, 80/80 (236 × 35) – 4-pole, 60 Hz.....	70
Appendix	
Inquiry Sheet.....	72
Description of Certificates and Test Reports.....	74
Abbreviations and Terms.....	75



Regardless of the application – for our customers product quality and profitability are what matters. This is what GEA Flow Components is known for. Our engineers are specialists in everything that flows.

GEA Group Aktiengesellschaft

GEA is one of the largest suppliers of process technology for the food industry and for a wide range of other industries. As an international technology group, the company focuses on world-leading process solutions and components for sophisticated production processes.

GEA Flow Components

GEA offers well-engineered process components and services to ensure smooth production processes in the treatment of liquid products. We develop and produce a comprehensive product range that includes valve technology for all hygienic classes (Hygienic, UltraClean, Aseptic), hygienic pumps and cleaning technology.

GEA Flow Components products and services are available around the world through the international GEA network.



Around one quarter of the milk processed is handled by GEA equipment



Roughly every second liter of beer is brewed using GEA equipment and solutions



Every fourth liter of human blood is handled by GEA equipment

State-of-the-art hygienic design

GEA Flow Components meet the highest hygienic standards where required, such as EHEDG and 3-A standards.

Hygienic valves and components from GEA form the core component of matrix-piped process plants.

When it comes to sterile applications, GEA offers both UltraClean and Aseptic valves and systems. The hermetic sealing of the product area provides a maximum level of process line isolation and thus contributes to process and product safety.

The hygienic pump range from GEA includes centrifugal pumps (single-stage, multi-stage and self-priming), as well as rotary lobe pumps.

GEA cleaning devices – whether index, orbital, rotary or static – achieve optimum cleaning results in multiple industries. GEA product recovery systems help to recover valuable products and reduce both waste disposal costs as well as water and detergent consumption.

Applications

- Beverages
 - Beer, juice, smoothies, and more
- Dairy processing
 - Milk, yoghurt, cheese, and more
- Food
 - Sauces, pastes, ketchup, mayonnaise, and more
- Pharma/Biotech
 - Pharmaceuticals, biotech, cosmetics, health care, and more
- Chemicals
 - Fine chemicals, bulk chemicals, cleaning agents, and more



Hygienic Valve Technology

A complete range of economically designed Hygienic valves for complex tasks as well as basic functions, helping producers to achieve high product quality and efficiency.



Aseptic Valve Technology

UltraClean and Aseptic valves are suitable for production processes which require a higher safety protection against contamination from the environment and thus warrant microbial stability of the product over the whole process.



Hygienic Pump Technology

A great variety of Hygienic pumps with sensibly rated high efficiency motors and carefully designed flow paths, driving economic efficiency and sustainable operation.



Cleaning Technology

Index, orbital, rotating and static cleaners in a complete range, developed with special emphasis on saving valuable resources in the cleaning process.

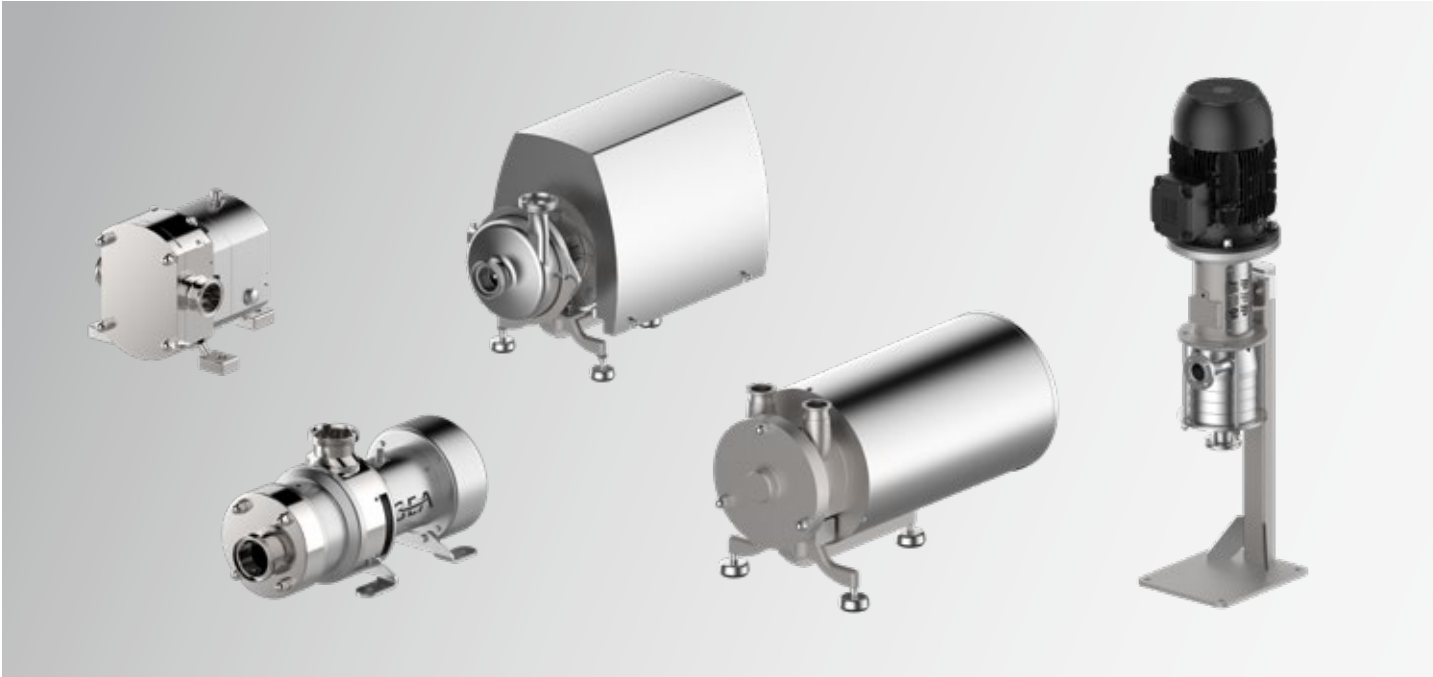

Gentle product handling, continued reliability and economic efficiency are key characteristics of the state-of-the-art hygienic pumps in the GEA Flow Components range.

Maximum reliability and cost control

Because GEA customers rely on the safe, continuous operation of their production systems, GEA pumps are optimized for uncompromising reliability in all applications. The great number of pumps currently in operation is proof of their robust design, long service life and ease of maintenance.

Applying GEA pumps to production processes can significantly reduce operational costs. Sensibly rated high-efficiency motors in all the required dimensions keep energy consumption as low as possible. The product is conveyed evenly and gently for higher product quality and improved processing and distribution options.

Economical

- Higher product quality
- Reduced consumption of energy, water and cleaning media
- Reduced time and personnel costs for maintenance and cleaning



Hygienic and sustainable design

GEA pumps comply with all relevant hygiene standards and norms, with continuous documentation and up-to-date certifications safely ensuring judicial security.

Carefully designed flow paths free of dead zones ensure optimum cleaning and utilization of the conveying energy. Lower consumption of energy, water and chemicals helps to protect climate and environment, observe international regulations and promote the producer's standing with customers and authorities.

Long-term partnership

The GEA Hilge Hygienic Pumps Competence Center situated in Bodenheim, Germany, is the primary point of contact for GEA customers and partners to plan individual solutions. The worldwide GEA sales and service network provides further assistance with support offers covering the entire lifecycle of the pump.

Sustainable

- Lower climate and environmental impact
- Sustainable, environmentally friendly production processes
- High standards for hygienic processing and care of products

Service-oriented

- Individual engineering support
- Shortest possible downtime of production
- Individual service concept

Two modern pump lines for maximum efficiency

Two product lines, GEA VARIPUMP and GEA SMARTPUMP, form a highly versatile pump range with a multitude of adaption options to ensure simpler operation, higher-quality production, and reduced consumption of valuable resources.

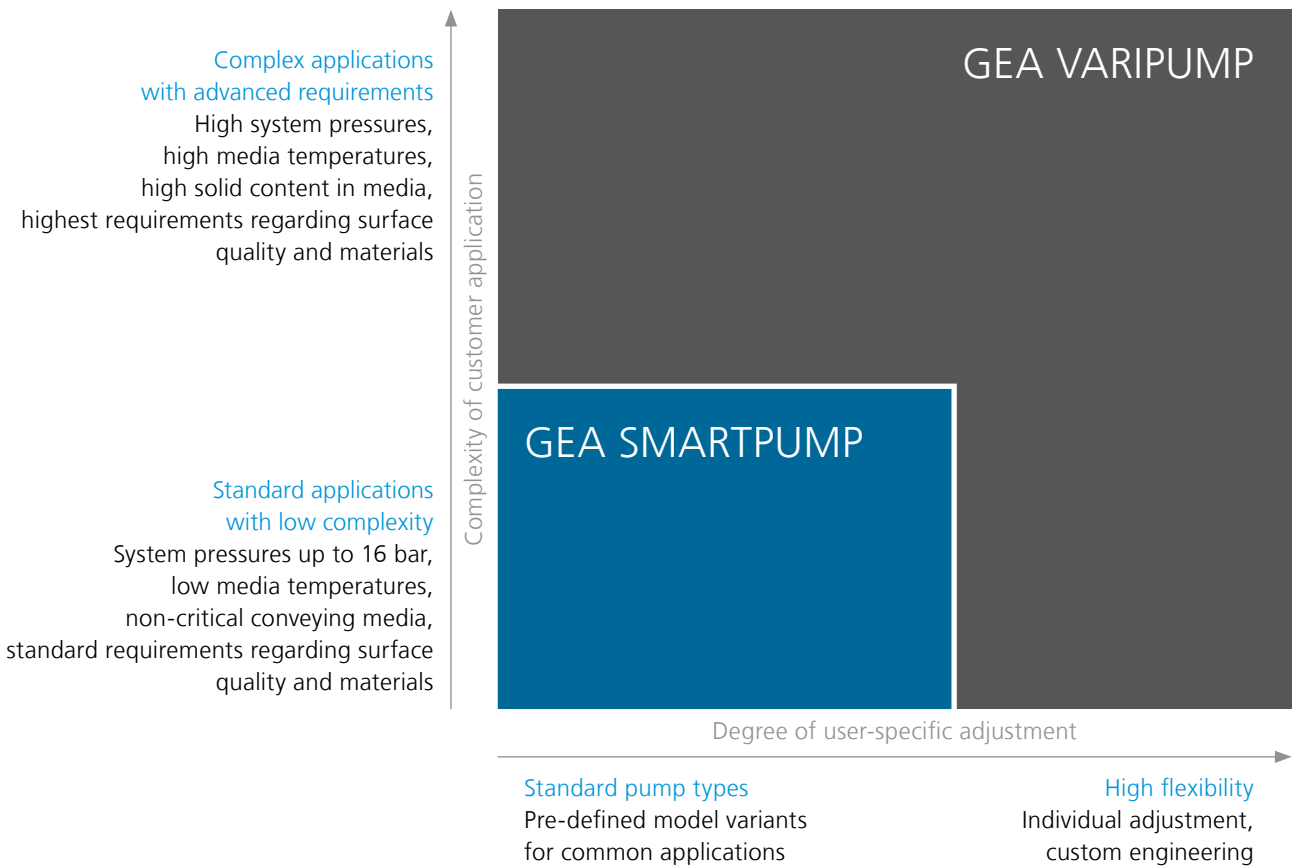

GEA VARIPUMP

The pump series in the GEA VARIPUMP line have been conceived for extreme application demands. The pumps are individually optimized by GEA for each task.

GEA VARIPUMP models are made entirely without die-cast components, offering high-quality surfaces and materials that meet stringent demands even in the sensitive pharmaceutical industry, further ensured by complementing services, e.g. Witnessed Factory Acceptance Test (FAT).

With a great variety of set-up and customizing options the pumps can be adapted individually to any production process, for lower operational costs and maximum system efficiency.

- Developed for advanced application conditions
- Project-specific customization
- Surface roughness up to $R_a \leq 0.4 \mu\text{m}$
- Product-wetted materials according to specific requirements (e.g. no cast parts, $F_e \leq 1\%$ optional)

GEA SMARTPUMP

The GEA SMARTPUMP line comprises highly standardized and attractively priced pump series for common, often-used applications at standard conditions. The pumps are easy to select and ready for fast delivery. Within pre-defined parameters, the standard models can be configured to individual tasks.

The modular construction using high-value materials, the proven “Hygienic Design” and easy-to-apply standardized spare parts all recommend GEA SMARTPUMP pumps for use in cost-critical production systems – at no compromise in terms of quality.

- Application for common and clearly defined “standard” process tasks
- Simple selection and configuration
- Fast delivery
- Standardized spare parts

Single-stage, VARIPUMP
2-pole, 50 Hz

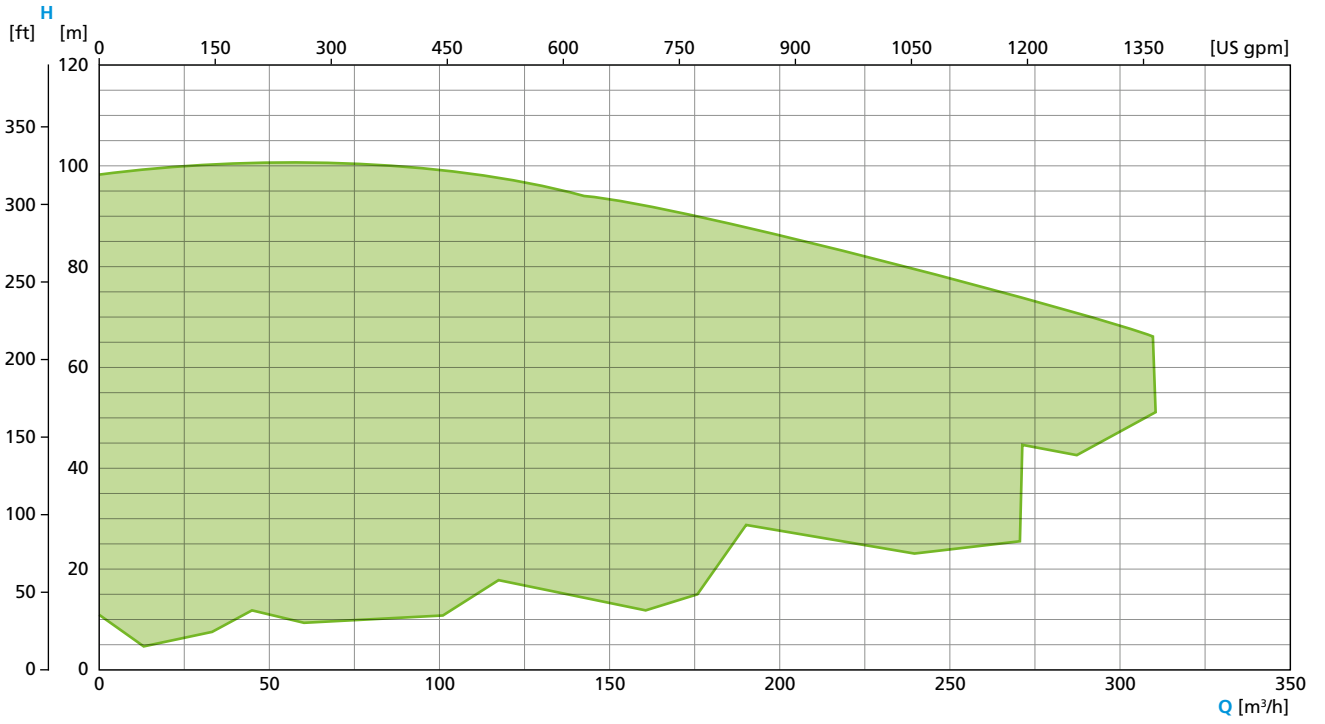

Single-stage, VARIPUMP*
4-pole, 50 Hz

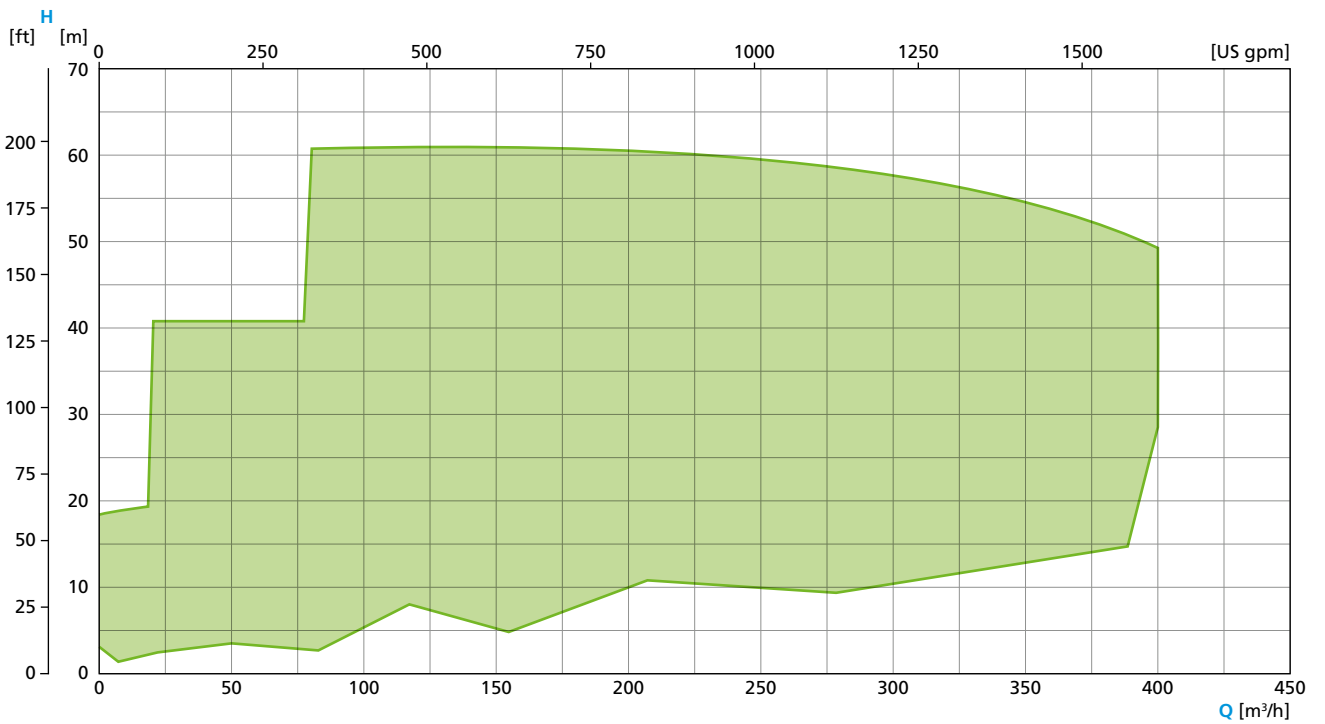

* GEA Hilge HYGIA & GEA Hilge MAXA (up to 150/400)

Single-stage, VARIPUMP*
4- and 6-pole, 50 Hz

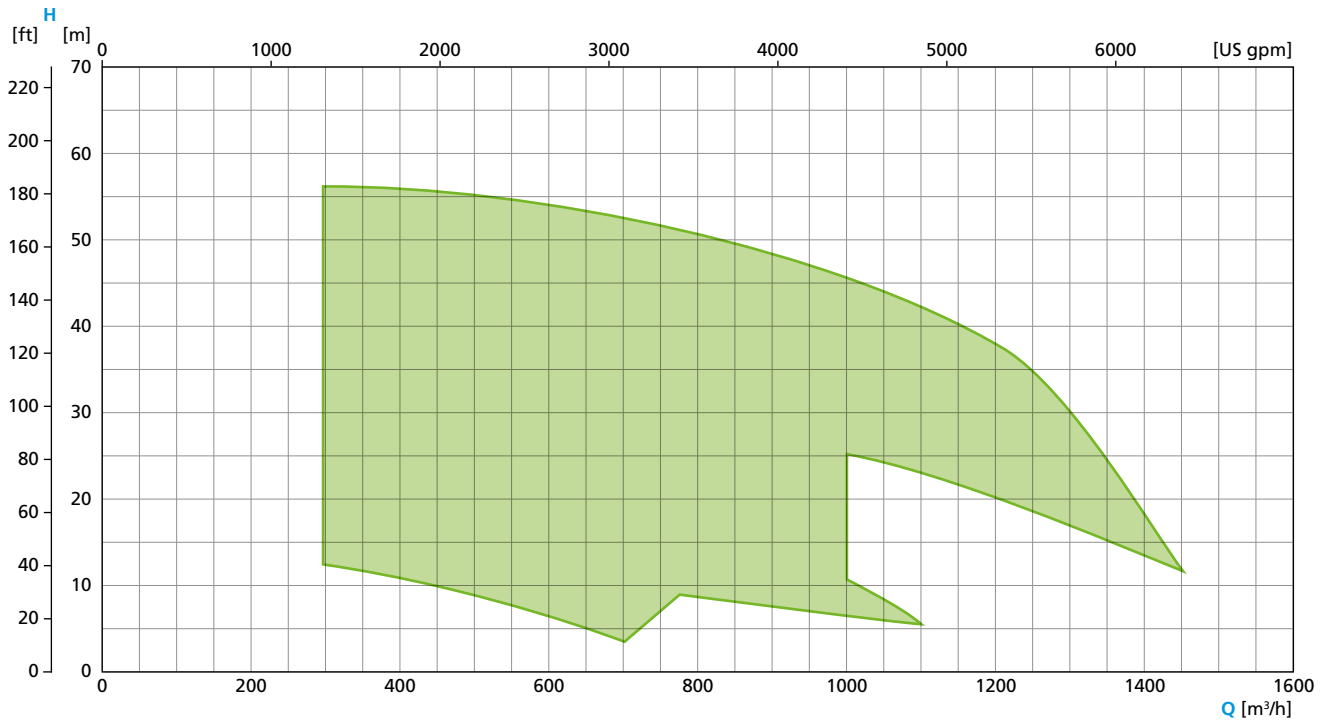

* GEA Hilge MAXA 200/400 and 250/400

Single-stage, VARIPUMP
2-pole, 60 Hz

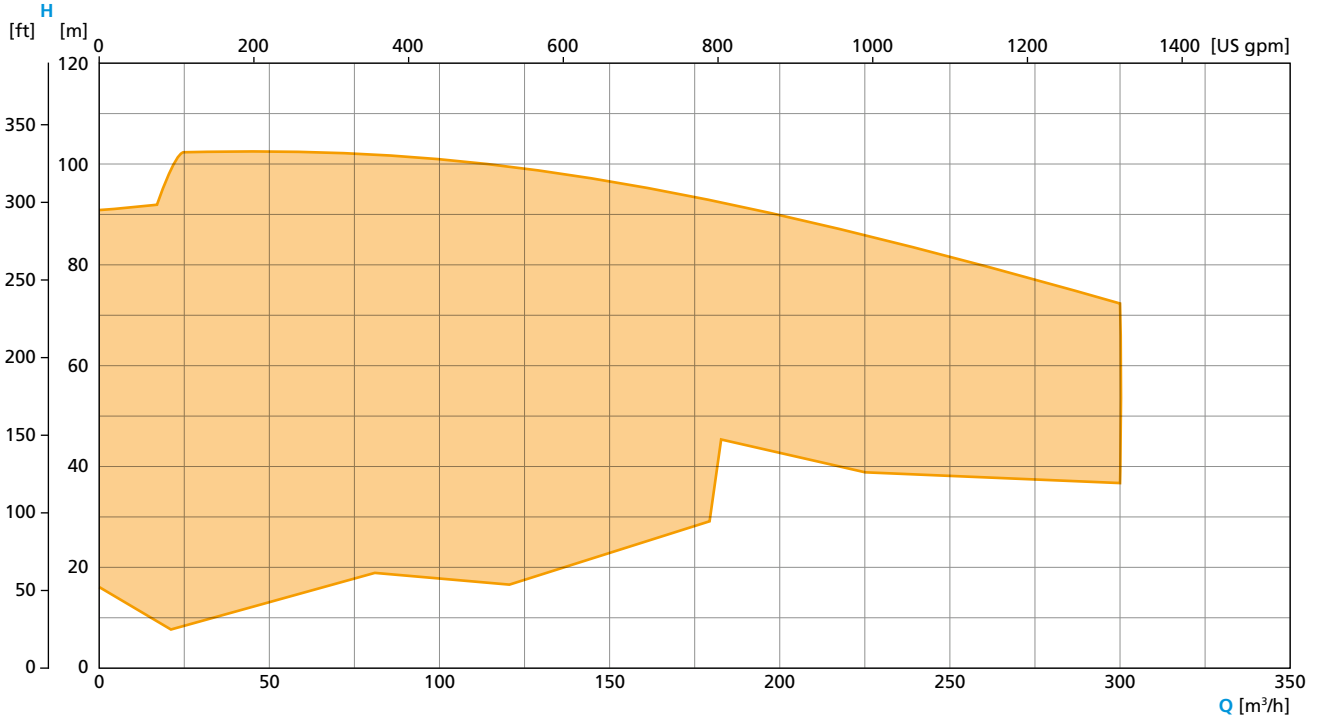

Single-stage, VARIPUMP
4-pole, 60 Hz

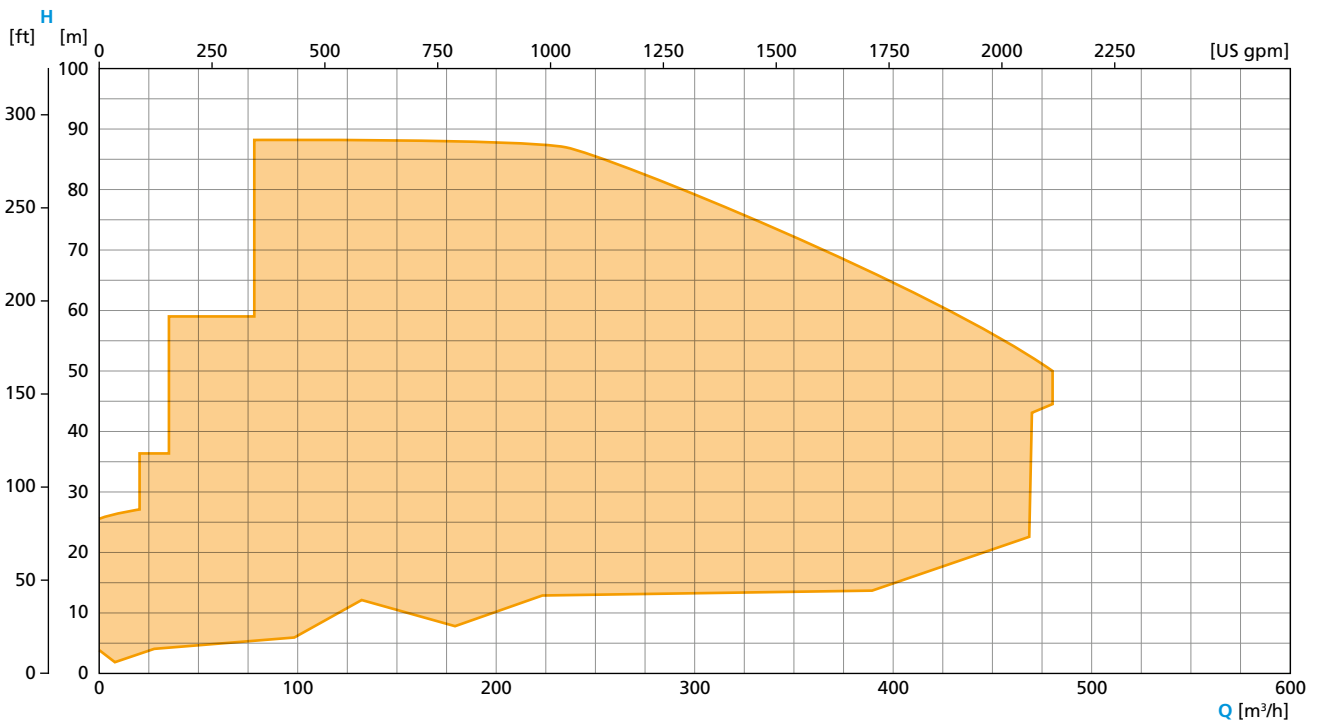

Single-stage, VARIPUMP
6-pole, 60 Hz

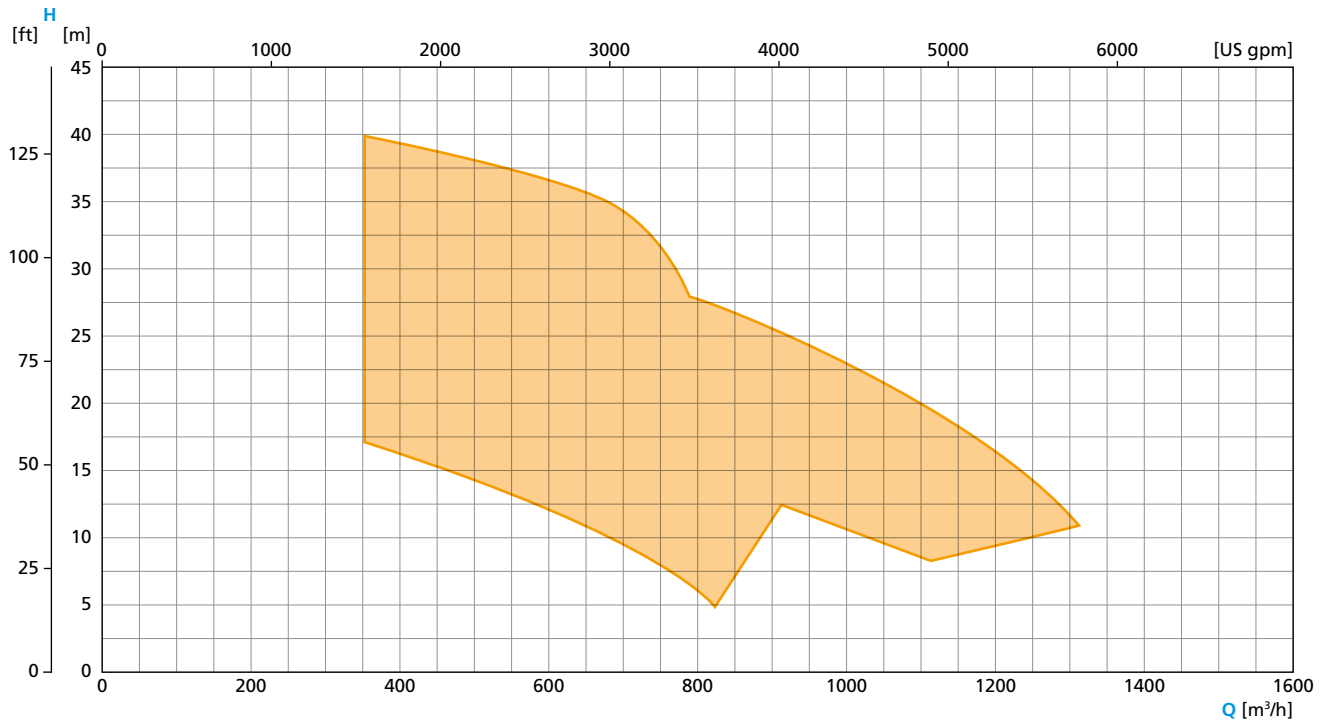

Multi-stage, VARIPUMP
2-pole, 50 Hz

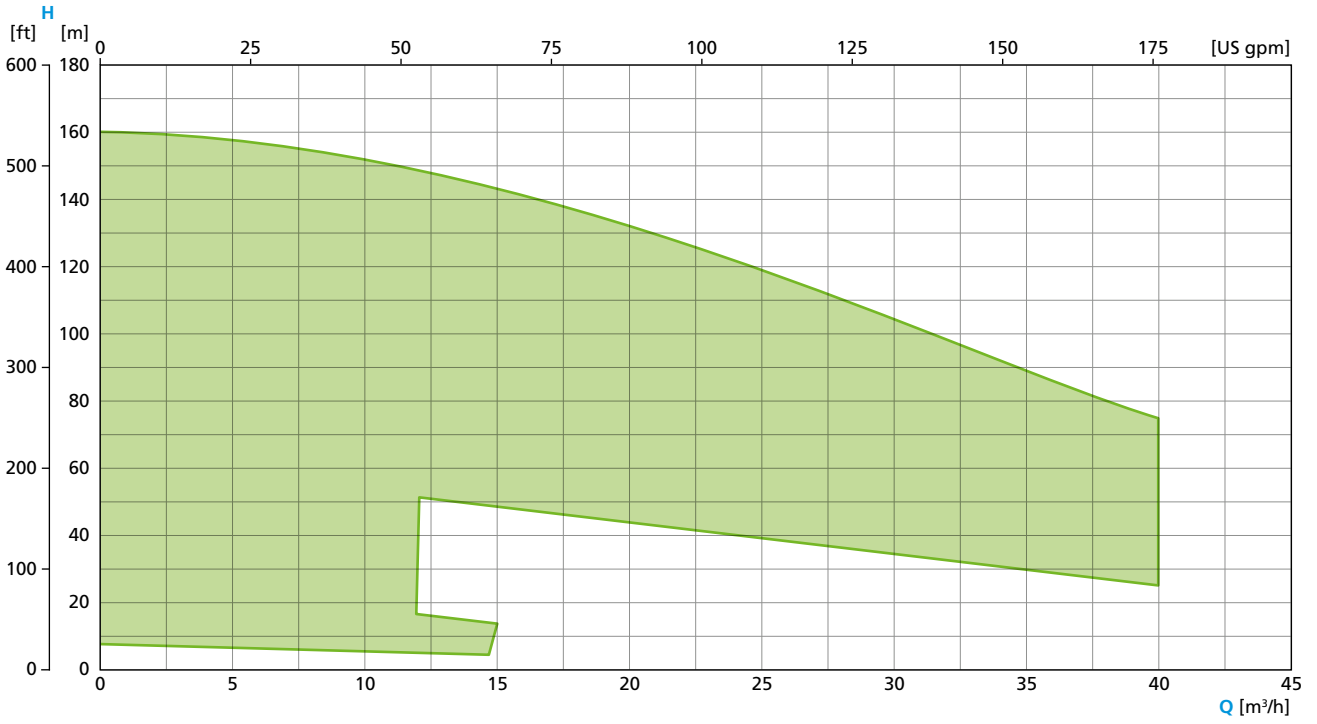

Multi-stage, VARIPUMP
2-pole, 60 Hz

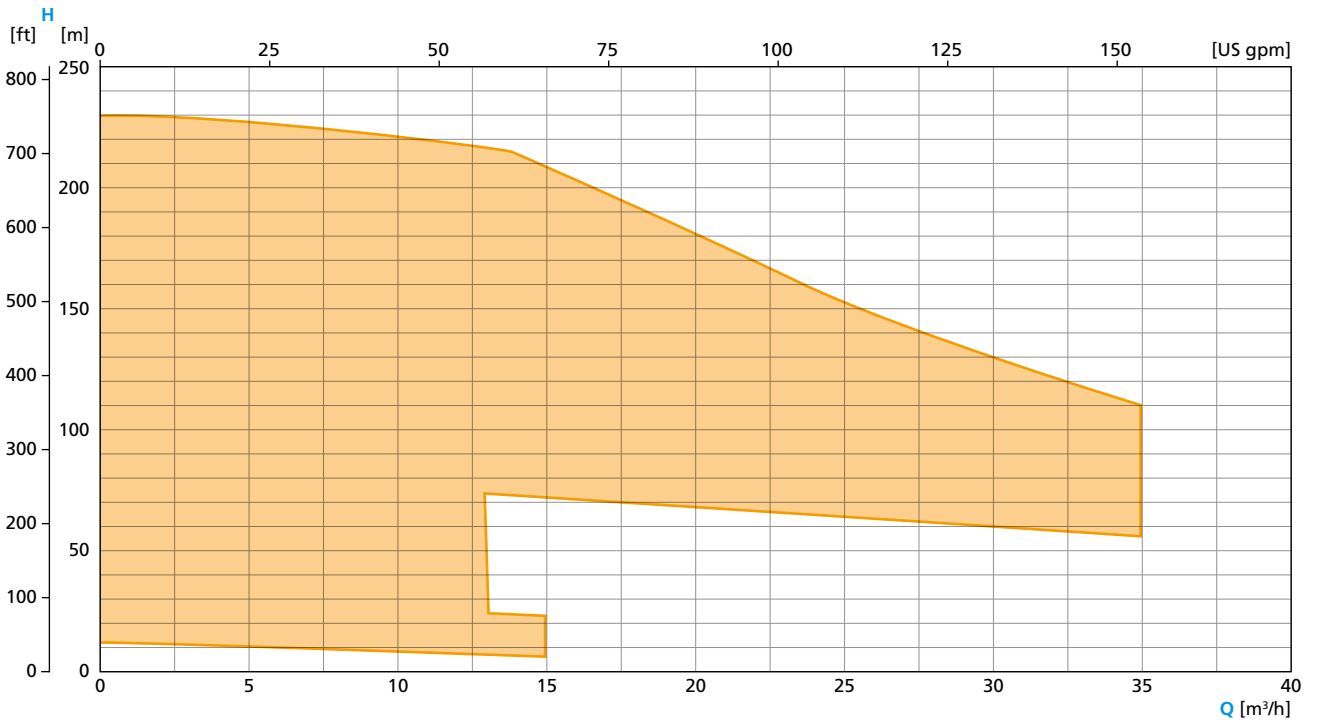

Single-stage, SMARTPUMP
2-pole, 50 Hz

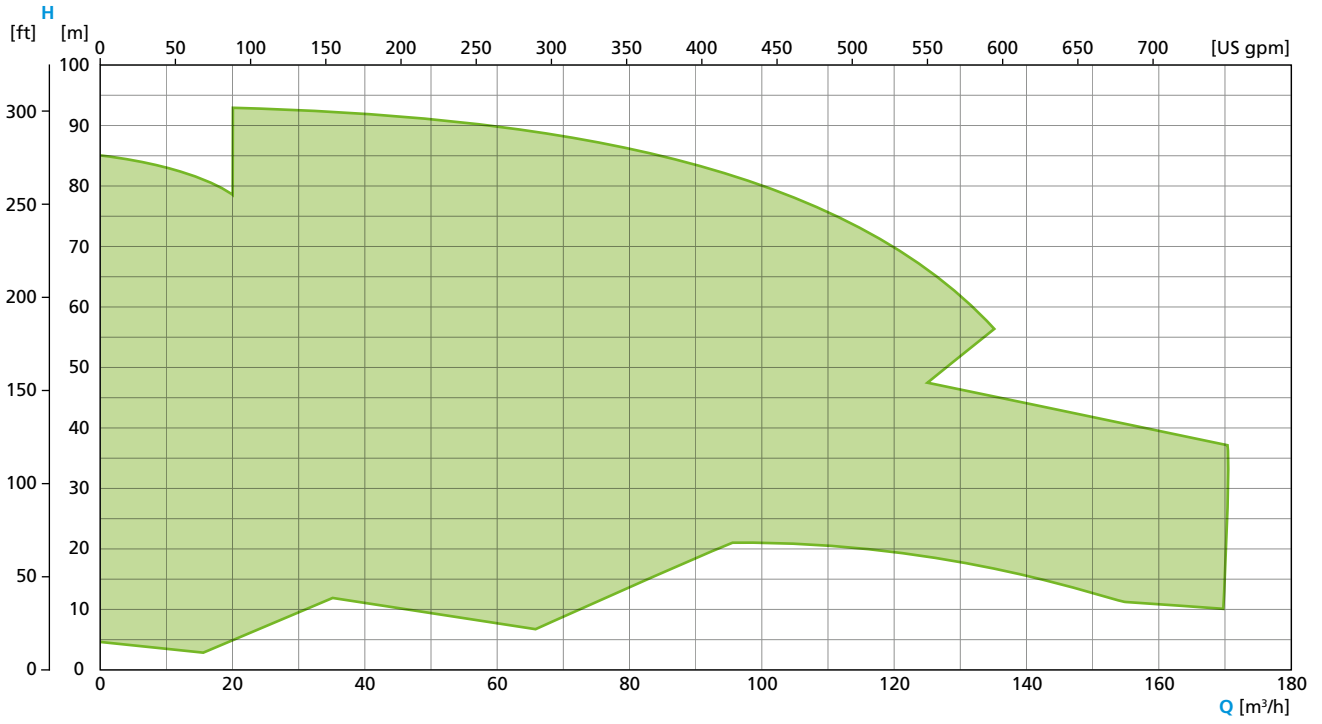

Single-stage, SMARTPUMP
4-pole, 50 Hz

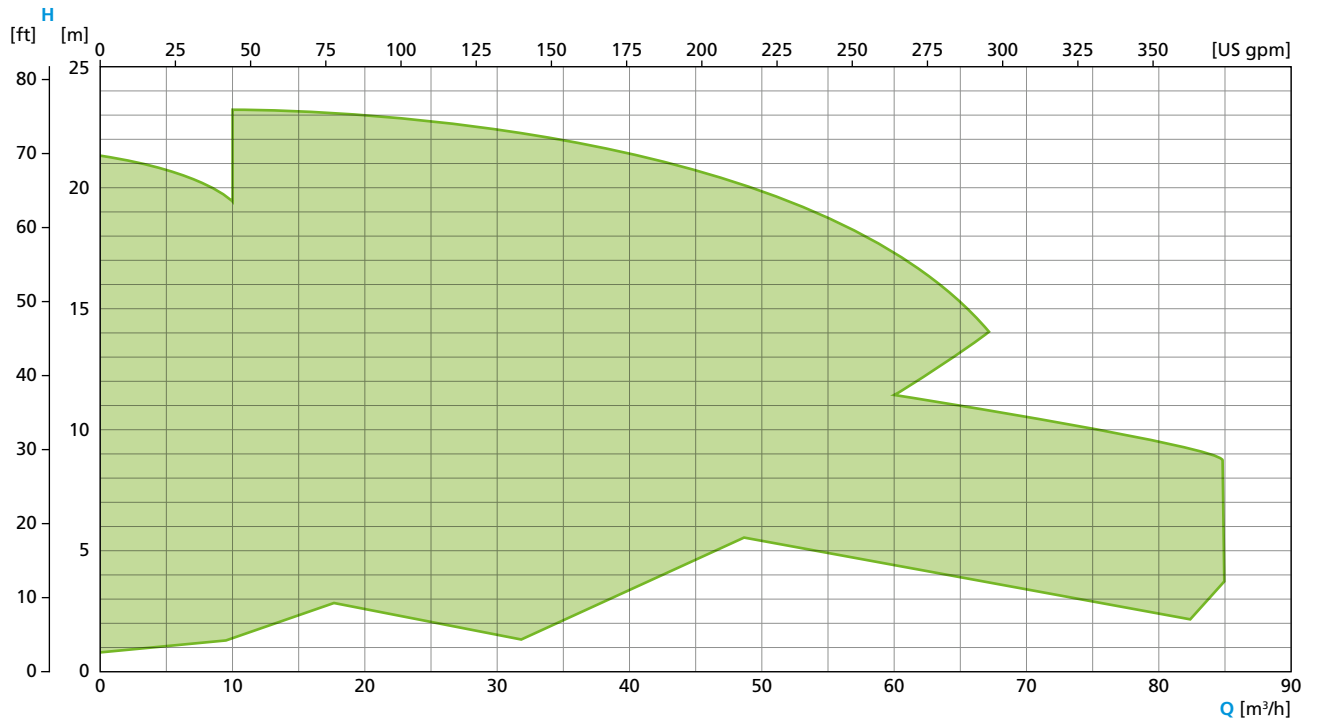

Single-stage, SMARTPUMP
2-pole, 60 Hz

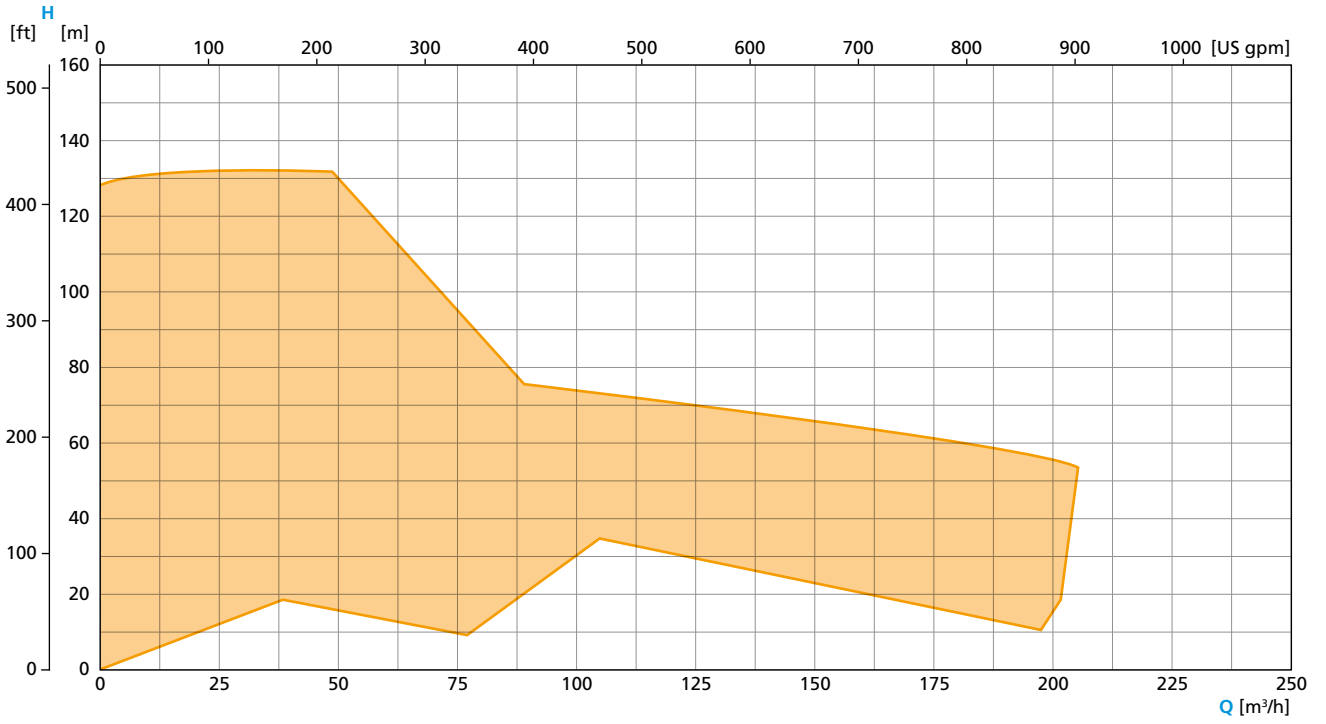

Single-stage, SMARTPUMP
4-pole, 60 Hz

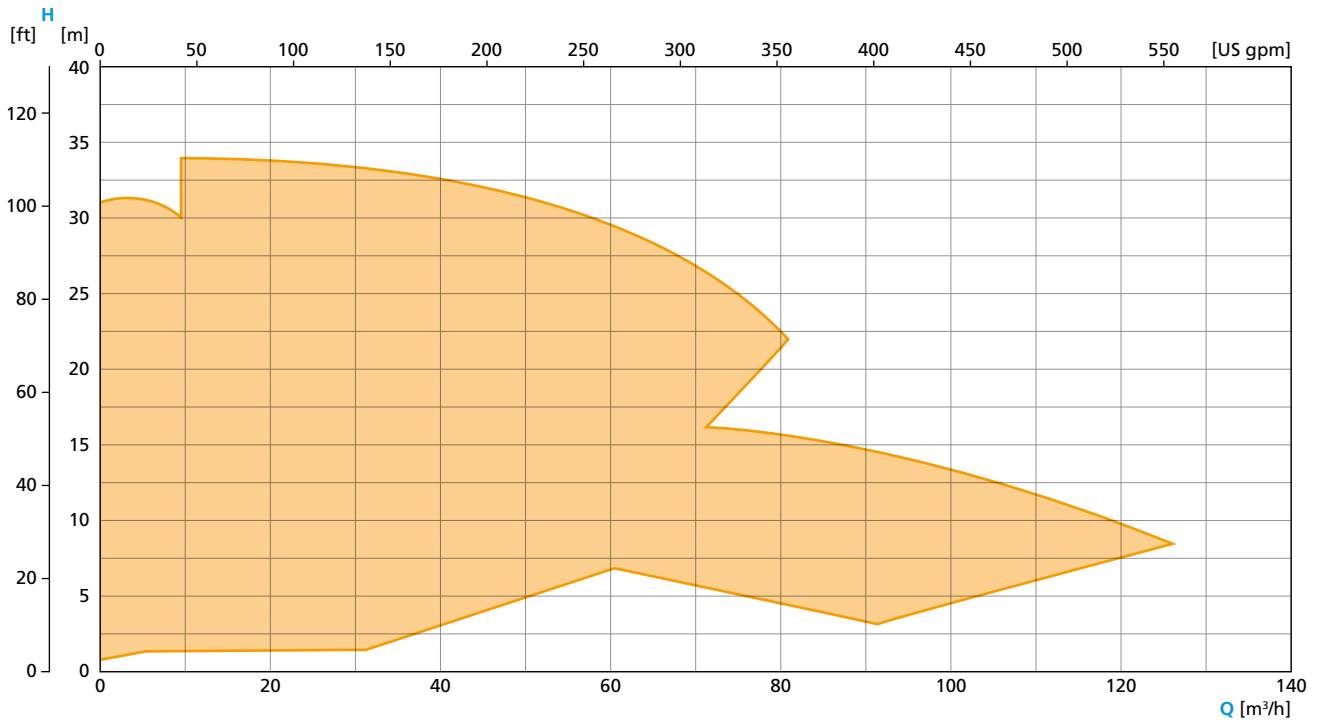

Multi-stage, SMARTPUMP
2-pole, 50 Hz

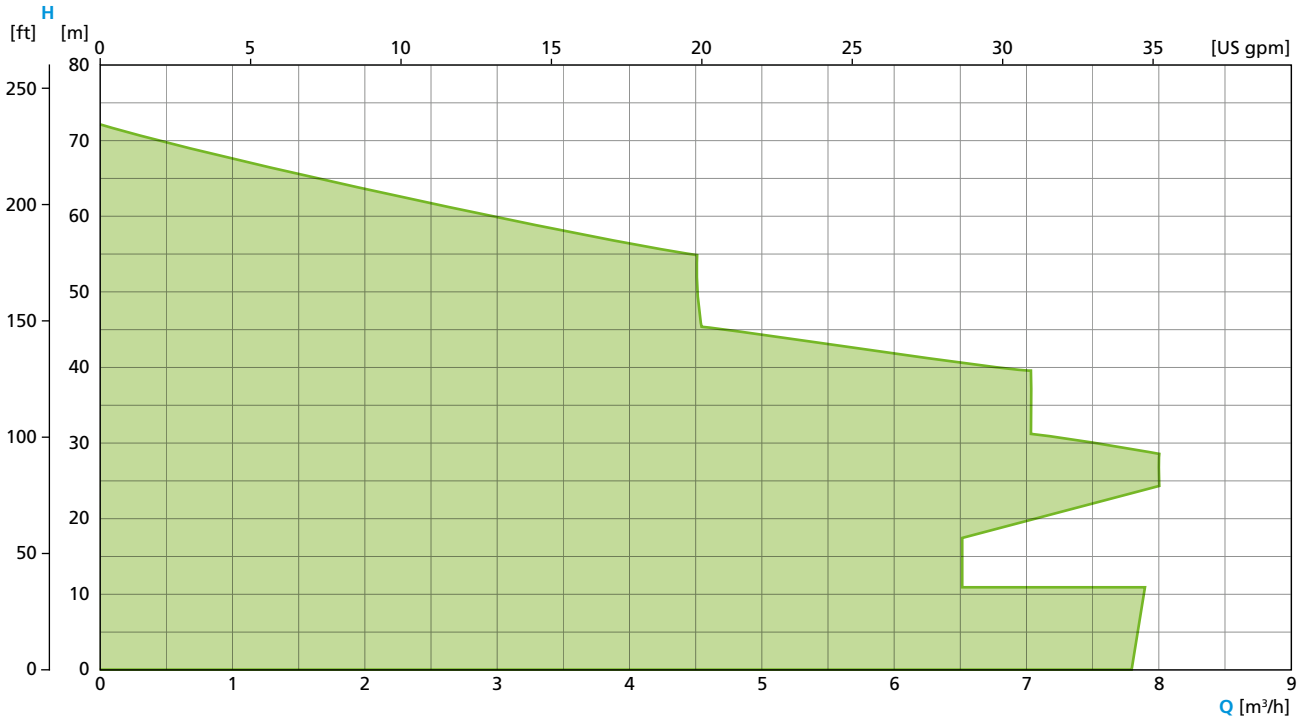

Multi-stage, SMARTPUMP
2-pole, 60 Hz

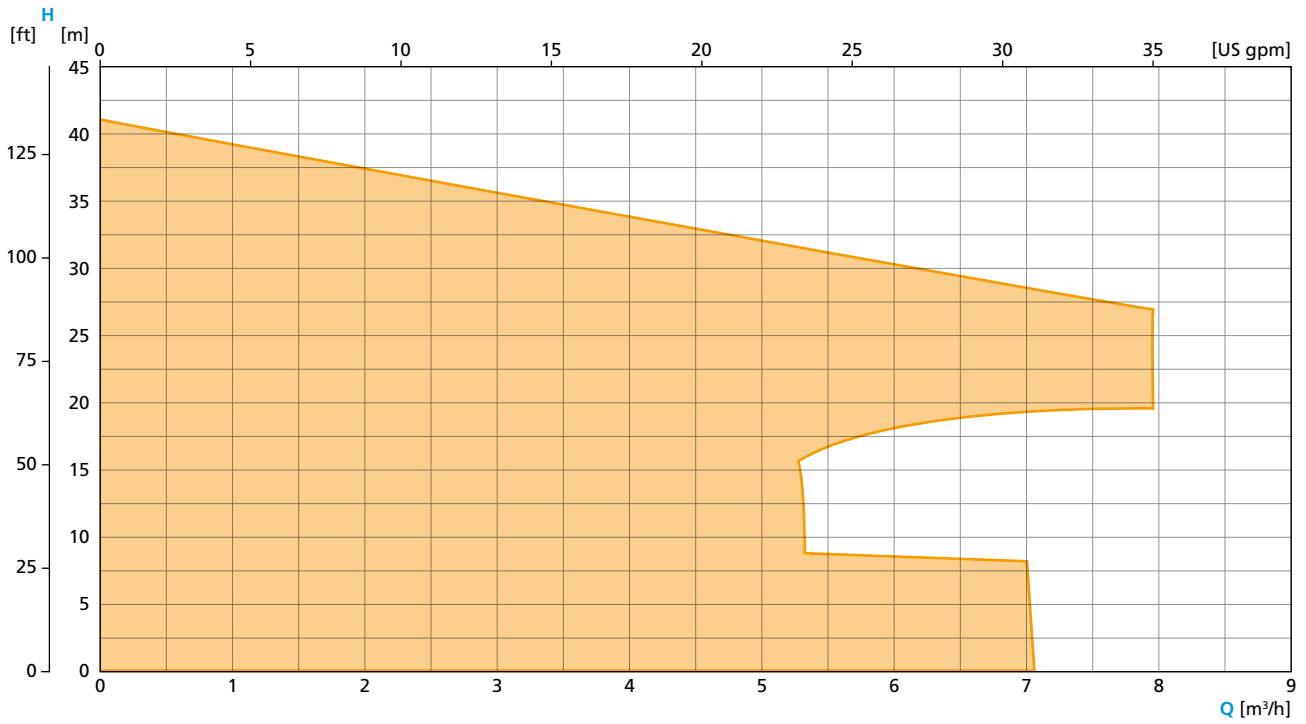

Single-stage, self-priming, VARIPUMP
4-pole, 50 Hz

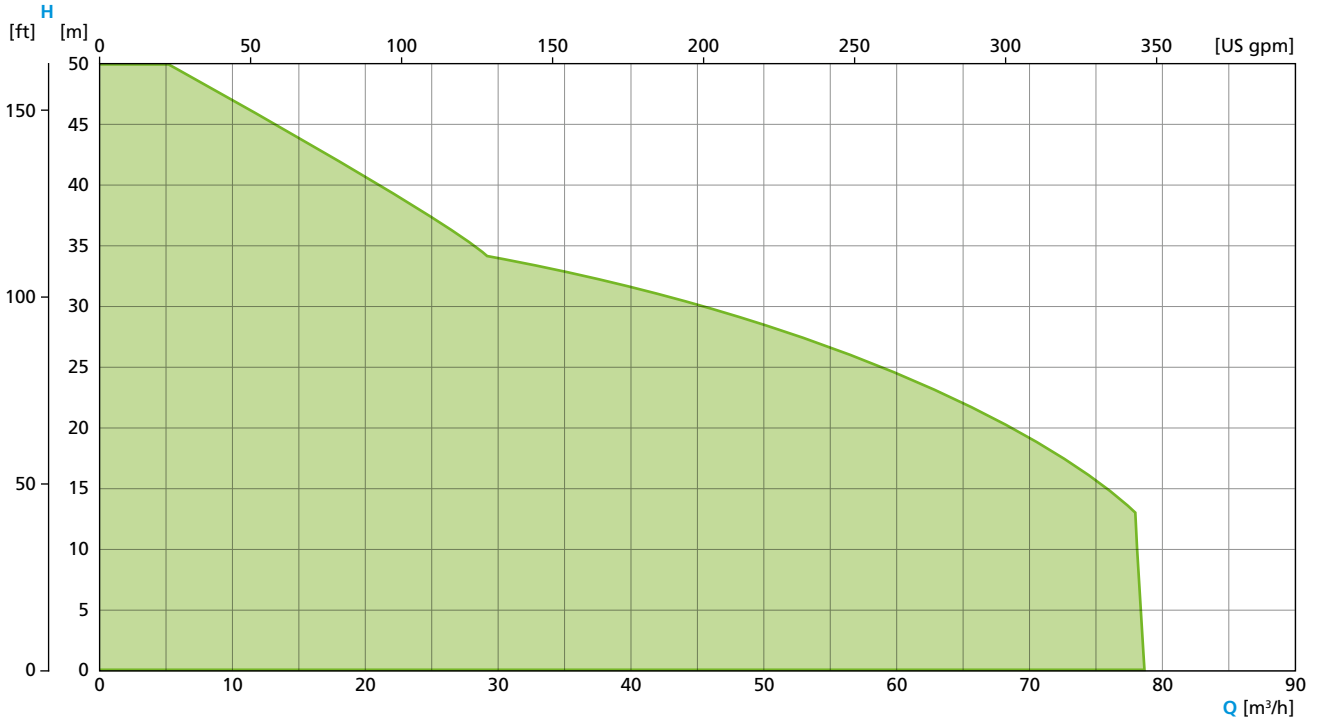

Single-stage, self-priming, VARIPUMP
4-pole, 60 Hz

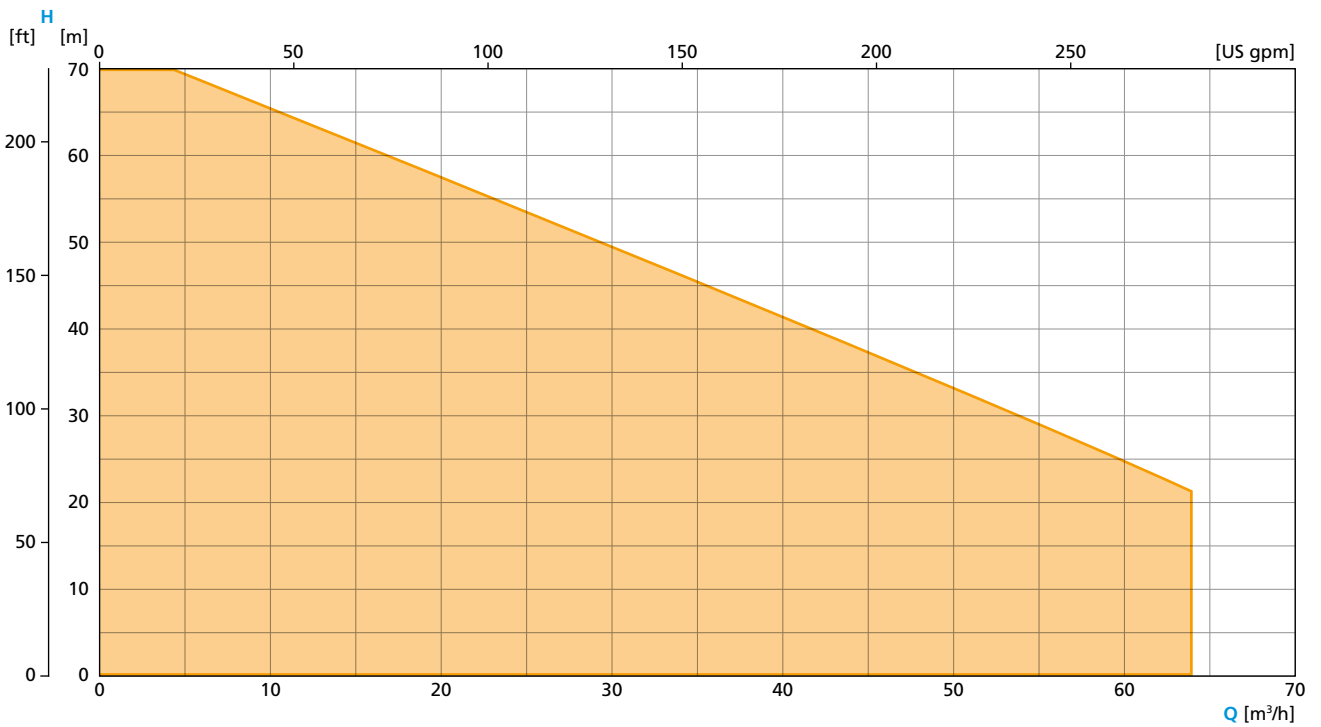

Single-stage, self-priming, SMARTPUMP
2-pole, 50 Hz

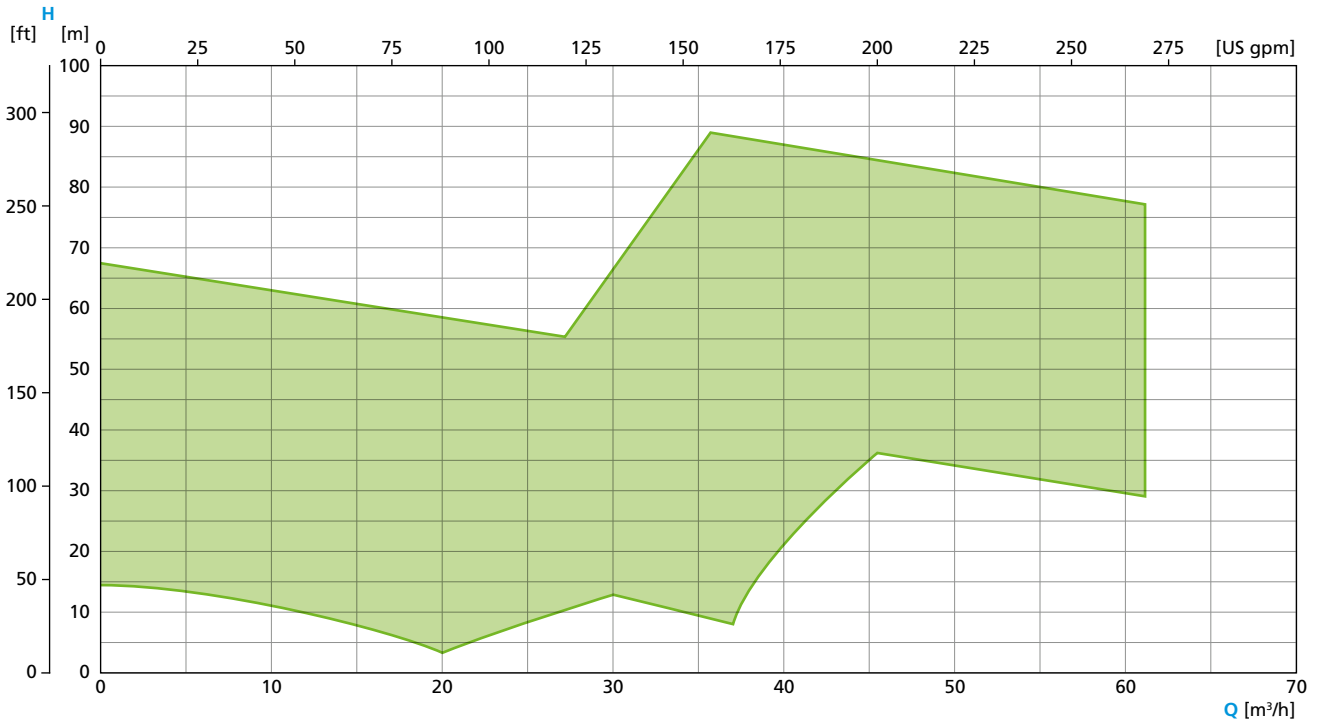

Single-stage, self-priming, SMARTPUMP
2-pole, 60 Hz

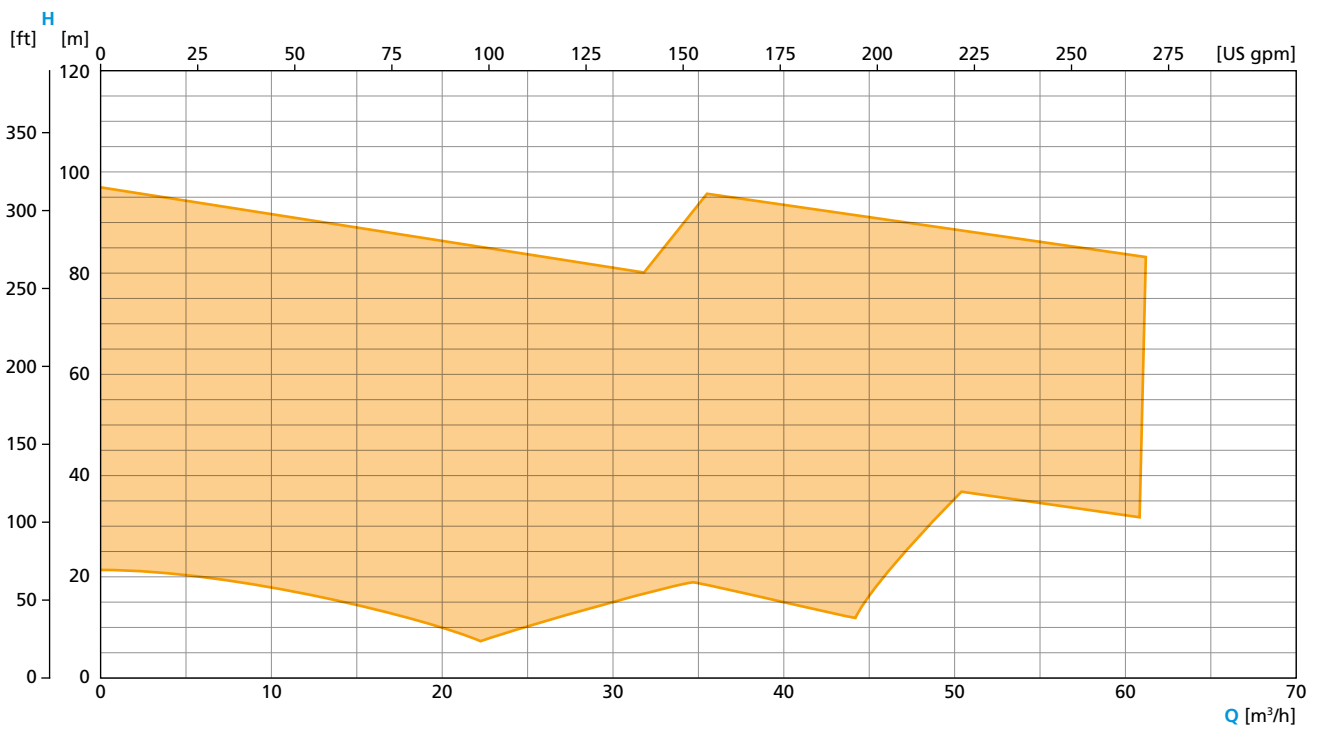

Rotary Lobe Pump, VARIPUMP

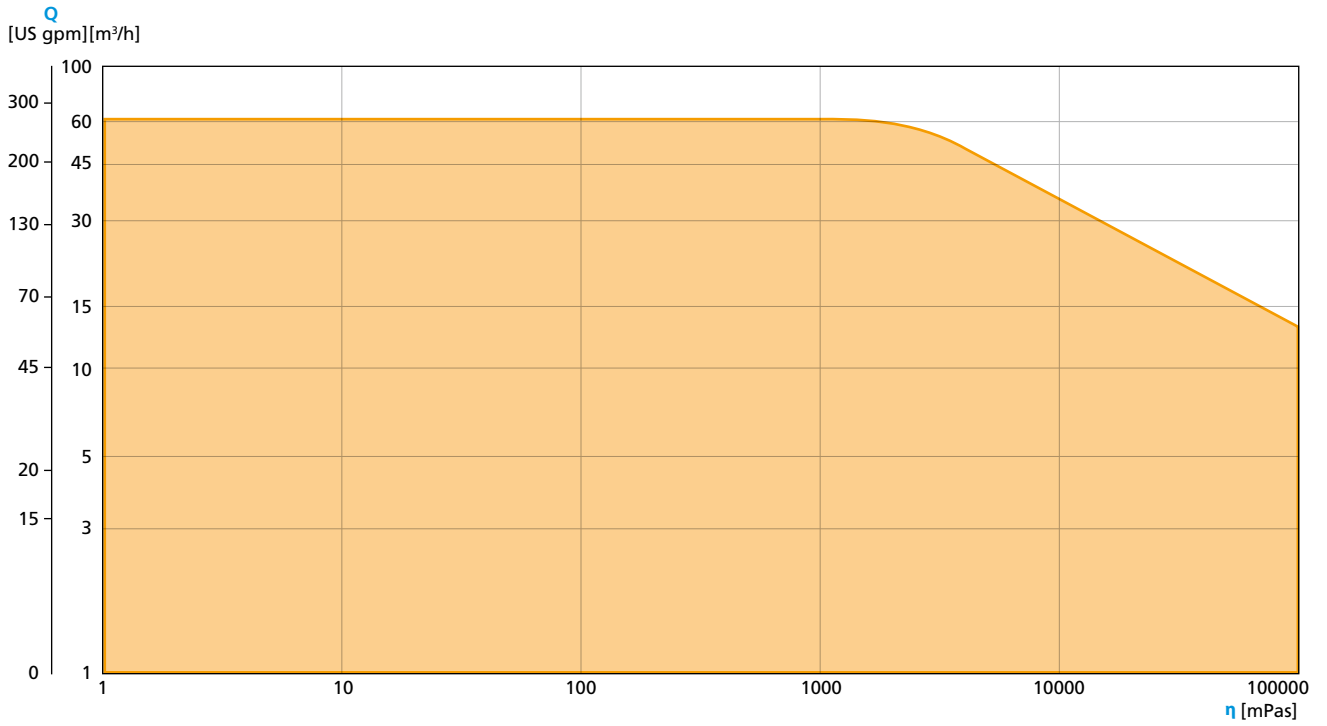

Twin Screw Pump, VARIPUMP

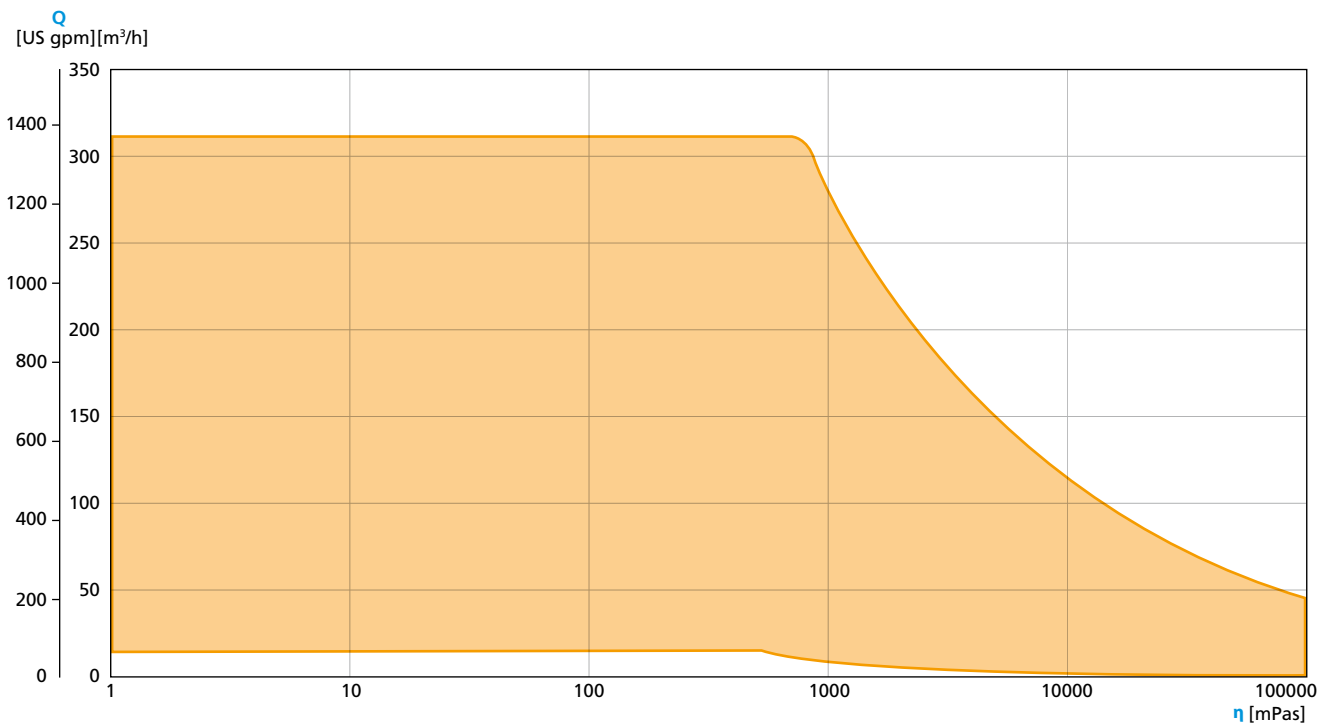

GEA Hilge HYGIA/HYGIA H

The “Swiss Knife” among the hygienic pumps. Premium quality and highest flexibility of customization ensure successful application in the food, beverage, and pharma industries.

Technical data	50 Hz	60 Hz
Max. flow rate	200 m³/h	175 m³/h
Max. head	72 m	105 m
System pressure	16 / 25 / 64 bar	

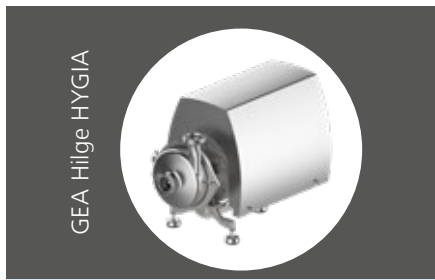

GEA Hilge HYGIA

GEA Hilge MAXA

A single-stage centrifugal pump designed for heavy-duty operation in industrial processes. The major dimensions and characteristics of these pumps correspond to DIN EN 733 and DIN EN 22858.

Technical data	50 Hz	60 Hz
Max. flow rate	1,450 m³/h	1,320 m³/h
Max. head	100 m	100 m
System pressure	10 bar	

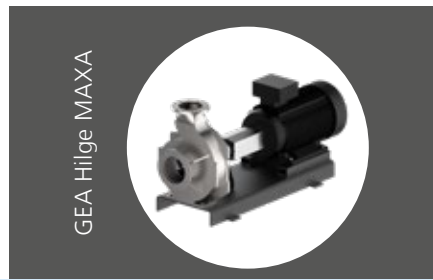

GEA Hilge MAXA

GEA Hilge SIPLA

A single-stage self-priming side channel pump, especially suited for SIP/CIP return systems and applications with high gas content. Right- and left-hand rotation can be freely adjusted for additional application options.

Technical data	50 Hz	60 Hz
Max. flow rate	78 m³/h	64 m³/h
Max. head	47 m	60 m
System pressure	10 bar	

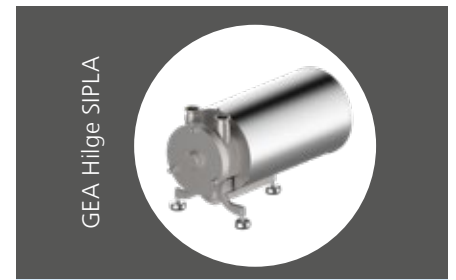

GEA Hilge SIPLA

Single-stage end-suction centrifugal pumps

Single-stage self-priming centrifugal pumps

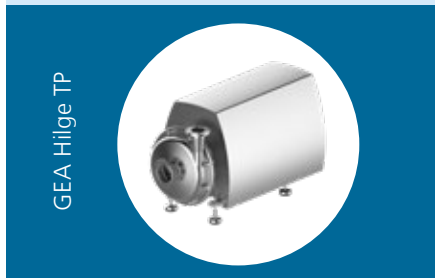

GEA Hilge TP

GEA Hilge TP

The GEA Hilge TP is the smart solution for standard applications. The single-stage centrifugal pump suits a wide range of applications and offers uncompromising hygiene and quality.

Technical data	50 Hz	60 Hz
Max. flow rate	210 m³/h	240 m³/h
Max. head	90 m	130 m
System pressure	16 bar	

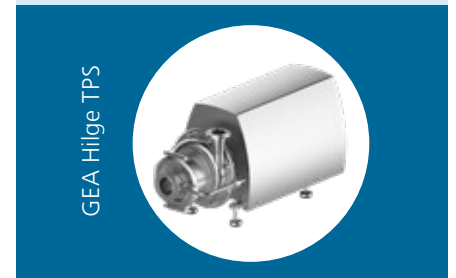

GEA Hilge TPS

GEA Hilge TPS

This self-priming centrifugal pump is the solution of choice especially for emptying tanks as well as for conveying products containing gas, e.g. CIP return systems.

Technical data	50 Hz	60 Hz
Max. flow rate	125 m³/h	155 m³/h
Max. head	95 m	138 m
System pressure	16 bar	

GEA VARIPUMP

Wide model range with numerous variants. Customization to specific customer requirements

GEA SMARTPUMP

Clearly defined list of models, limited to standard requirements no other variants

GEA Hilge CONTRA

Single- and multi-stage centrifugal pumps are available in this series. The hygienic design in every detail provides perfect solutions to numerous tasks in sterile and hygienic processes.

Technical data	50 Hz	60 Hz
Max. flow rate	40 m ³ /h	35 m ³ /h
Max. head	160 m	230 m
System pressure	25 bar	

GEA Hilge NOVALOBE

This rotary lobe pump has been specifically designed for highly viscous media – and for applications where gentle pumping or dosing is required. The pump is fully drainable with vertical ports.

Technical data	50 / 60 Hz
Max. displacement	2.1 l/rev
Max. differential pressure	16 bar
System pressure	10/16 bar

GEA Hilge NOVATWIN

The GEA Hilge NOVATWIN is a flexible twin screw pump. It fulfills the highest hygienic standards for gentle product handling as well as CIP with one pump only.

Technical data	50 / 60 Hz
Max. displacement	5.1 l/rev
Max. differential pressure	25 bar
Max. flow rate	310 m ³ /h
System pressure	up to 30 bar



Multi-stage centrifugal pumps

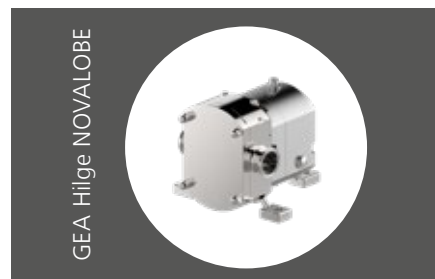

Rotary-lobe pumps



Twin-screw pumps

Positive displacement pumps

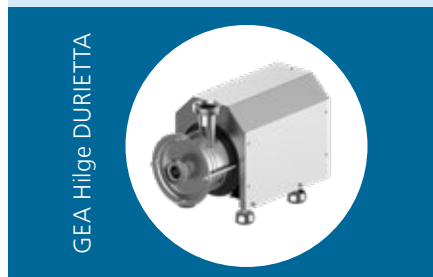

GEA Hilge DURIETTA

This end-suction single- or multi-stage centrifugal pump in a very compact design has been created for applications with low flow rates at high flow heads.

Technical data	50 Hz	60 Hz
Max. flow rate	8 m ³ /h	8 m ³ /h
Max. head	72 m	41 m
System pressure	8 bar	

The certificates listed here are valid for corresponding GEA pump models. Pumps conforming to the requirements of the European Hygienic Engineering and Design Group (EHEDG) as well as 3-A Sanitary Standards, Inc. (3-A SSI) are available for numerous fields of application.

Moreover, independent, standardized tests have confirmed the efficient, problem-free cleaning ability of numerous pumps – for optimum safety and economic gain.

EHEDG certificates apply only to the specific pump type as listed. However, they may be transferred to specific other pump types, owing to identical housing designs and flow path geometries.

Document	GEA Hlge HYGIA / HYGIA H	GEA Hlge TP / TPS	GEA Hlge CONTRA	GEA Hlge MAXA	GEA Hlge DURIETTA	GEA Hlge SIPLA	GEA Hlge NOVALOBE	GEA Hlge NOVATWIN
3-A Sanitary Standard	•	•						
EHEDG certificate	•*	•	•*				•*	•*
FDA declaration of conformity	•	•	•	•	•	•	•	•
Declaration of compliance with the order 2.1 acc. to EN 10204	•		•	•	•	•	•	•
Test report 2.2 acc. to EN 10204	•	•	•	•	•	•	•	•
Inspection certificate 3.1 acc. to EN 10204	•	•	•	•		•	•	•
EAC-Certificate	•	•	•	•	•	•	•	•
Surface roughness test report	•	•	•	•			•	•
Delta ferrite test report	•		•				•	•
Acoustic measurement test report	•	•	•	•	•	•	•	•
USP Class VI – declaration of conformity	•	•	•			•	•	•
Certificate in acc. with the regulation (EG) No. 1935/2004	•	•	•	•	•	•	•	•
Certificate DIN EN ISO 9001:2015	•	•	•	•	•	•	•	•

Many more certificates on request
Subject to change without notice.

* registered for certification/recertification



GEA Hilge SIPLA Adapta on combi foot

Features and benefits

- Good suction performance enables short process times, even for media with high gas content
- Process flexibility through clockwise and counterclockwise rotation in standard version (advantage especially for mobile pumps)
- Quick and easy motor change due to Adapta Design, pump remains in the pipeline
- Optimized stocking of wear parts through GEA Hilge sealing concept for SIPLA, CONTRA, HYGIA
- Ideal adaptation to customer requirements through variability (e.g. connections, seals, mounting)
- Long service life of wear parts due to low-vibration running
- Pumping of media with viscosities up to 1000 mPas and thus pumping of product & CIP with only 1 pump results in lower investment costs

Technical data

	50 Hz	60 Hz
Flow head	47 m	60 m
Flow rate	78 m ³ /h	64 m ³ /h
Operating pressure	up to 10 bar	
Operating temperature	95 °C	
Sterilization temperature	140 °C (SIP)	
Max. pump efficiency	32 %	34 %

Applications

The GEA Hilge SIPLA pump range is suitable for the following application areas and products, due to the hygienic design and material selection:

Food and beverage industry

- Breweries (beer, wort, mash, yeast, etc.)
- Dairies (milk, milk-based mixed beverages, cheese manufacturing, etc.)
- Soft drinks (fruit juice, lemonade, mineral water, etc.)
- Wine and champagne cellars
- Distilleries (mash, distillates, etc.)
- Food manufacturing (marinades, brine, cooking oil, etc.)

Other industrial applications

- CIP return systems
- Applications with liquid containing entrained gas or air
- Filtration systems

Thanks to its unique side-channel design, the GEA Hilge SIPLA pump is capable of handling liquids with a high air content as in CIP return systems.

Design

GEA Hilge SIPLA pumps are self-priming, side-channel pumps, designed to meet the hygienic requirements of food and beverage process technologies.

The pumps are available in eight sizes with a variety of flexible versions. The pumps are CIP- and SIP- capable in compliance with the DIN EN 12462 performance criteria. The design fulfills the following requirements:

- QHD criteria
- EAC



Certification

Thanks to its unique side-channel design, the SIPLA pump is capable of handling liquids with a high air content as in CIP return systems.

All wet end parts are made of precision cast stainless steel 1.4404/AISI 316L. GEA Hilge SIPLA pumps are equipped with an open star impeller. See page 30.

The pump shaft is made of CrNiMo steel.

ATEX

For use in potentially explosive areas, Adapta pumps are available. These pumps, which possess an EC declaration of conformity in accordance with the ATEX guideline 2014/34/EU, correspond to device categories 2 or 3, and can be used in zone 1 or 2.



ATEX-Symbol

For explanation see chapter certificates on page 26.

Impeller

The pump type series SIPLA is offered with a star impeller.

Star impeller



Impeller version	Surface finish
Cast	$R_a \leq 3.2 \mu\text{m}$

The impeller is suitable for low-viscosity liquids and liquids containing low content of particles.

Materials

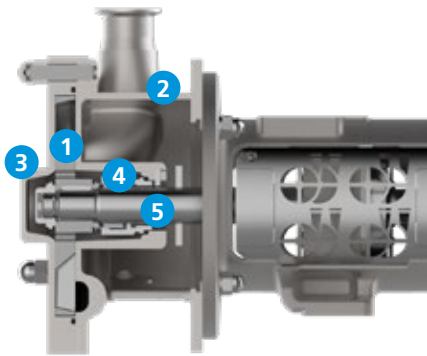

Material overview GEA Hilge SIPLA

Item	Component	Material	No.
1	Impeller	CrNiMo steel	316L (1.4404)
2	Pump casing	CrNiMo steel	316L (1.4404)
3	Front cover	CrNiMo steel	316L (1.4404)
4	Seal	Carbon/stainless steel/EPDM or FKM	
5	Pump shaft	CrNiMo steel	
	Shroud	Stainless steel	
	Foot	Stainless steel/ cast iron	

Motor

Standard motors are totally enclosed fan-cooled IEC motors (TEFC), protection class IP55.

Coating

Components not made of stainless steel are provided with one of the following coatings, depending on the design:

Version	Paint/coating	Coating thickness
Primer	2K epoxy resin	30–60 μm
	KTL coating	15–25 μm
Top coating	2K epoxy resin	50–70 μm
	2K polyurethane color	60 μm
	KTL coating	15–25 μm

Surface design

As standard, all wet end parts are electro-polished to improve corrosion-resistance and surface finish.

In order to meet the demands of the food and beverage industries, GEA has developed the surface and material requirements below:

Material	Surface
CrNiMo steel	$R_a \leq 3.2 \mu\text{m}$

Mechanical seal

GEA Hilge SIPLA pumps are equipped with a single mechanical seal or flushed single mechanical seal (Quench) with an optimal position in the pumped liquid. This ensures lubrication, cooling as well as CIP and SIP.

Standard mechanical seal material is carbon/stainless steel with EPDM elastomers. Shaft seals with SiC/SiC or FKM elastomers are available on request.

Design variants

Standard version	Description
GEA Hilge SIPLA Bloc	Horizontal installation, extended motor shaft
GEA Hilge SIPLA Bloc-SUPER	Horizontal installation, extended motor shaft, with stainless steel shroud

Bloc design

GEA hygienic pumps in compact Bloc design require small installation space. The motor has an extended stainless steel shaft. The modular design enables numerous installation variants.



SIPLA Bloc-SUPER on combi foot



SIPLA Bloc on motor foot

Standard version	Description
GEA Hilge SIPLA Adapta	Horizontal installation, supported pump shaft, standard motor
GEA Hilge SIPLA Adapta tronic	Horizontal installation, supported pump shaft, standard motor with integrated frequency converter
GEA Hilge SIPLA Adapta-SUPER	Horizontal installation, supported pump shaft, standard motor, stainless steel shroud

Adapta design

Pumps in Adapta design have a bearing bracket with a supported pump shaft. The connection between the pump shaft and the motor shaft is coupled with an elastic coupling. This design enables the use of various standard motors. The pump can remain in the system during engine demounting/mounting.



SIPLA Adapta on cast iron foot



SIPLA Adapta tronic on cast iron foot



SIPLA Adapta-SUPER on combi foot



SIPLA Adapta on trolley

Designs

The following overview lists common designs, installations and versions. Additional versions on request.

Description	Adapta	Bloc
Without foot	•	
On motor foot	•	•
On stainless steel trolley	•	•
On combi foot	•	•
With coupling	•	

Terminal box position

This terminal box positions are possible for all pumps without shroud.

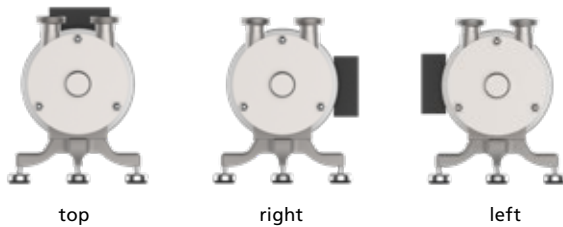

Possible terminal box positions

Pump connections

GEA Hilge offers the following standard connections for the GEA Hilge SIPLA pump range:

- Thread according to DIN 11851

Additional connections such as flange or clamp connections in accordance with DIN 11864/11853 and SMS are available on request.

Selected connections are also available with a drain port. You can find additional information in the connection selection guide on page 36.

Noise emissions

Measured values according to DIN EN ISO 3746 for pump units, measurement uncertainty 3 dB (A).

Pump size	Noise emission LpA [dB (A)]
GEA Hilge SIPLA 3.1	70
GEA Hilge SIPLA 6.1	70
GEA Hilge SIPLA 12.1	75
GEA Hilge SIPLA 18.1	81
GEA Hilge SIPLA 28.1	81
GEA Hilge SIPLA 52.1	83
GEA Hilge SIPLA 65.1	84
GEA Hilge SIPLA 90.1	85

The noise emissions of a pump are significantly affected by the given application. The values given here therefore serve only as a guide. Please contact GEA for more detailed information.

Type code

GEA Hilge SIPLA	3.1	BYY	32	/32	0.75	4
Pump range						
Size						
Design						
Nominal diameter of suction port (DN)						
Nominal diameter of discharge port (DN)						
Motor power (kW)						
Number of poles						

Design key

Code	Design
ADS	Adapta-SUPER
ADY	Adapta
ATS	Adapta-SUPER Tronic
BYS	Bloc-SUPER
BYY	Bloc

Designs

The following overview lists common designs, installations and versions. Additional versions on request.

Description	ADS	ADY	BYS	BYY
On cast iron foot	•	•		
On stainless steel foot	•	•		
On motor foot			•	•
On combi foot	•	•		
On stainless steel trolley	•	•	•	•
With integrated frequency converter (tronic) – from 1.5 kW to 18.5 kW (KTS to 7.5 kW)	•	•		
SUPER (motor with stainless steel shroud)	•		•	

Pump range GEA Hilge SIPLA

Pump range	GEA Hilge SIPLA 3.1	GEA Hilge SIPLA 6.1	GEA Hilge SIPLA 12.1	GEA Hilge SIPLA 18.1	GEA Hilge SIPLA 28.1	GEA Hilge SIPLA 52.1	GEA Hilge SIPLA 65.1	GEA Hilge SIPLA 90.1
Max. head [m] – 50 Hz / 60 Hz	24 / 35	32 / 47	24 / 35	28 / 41	36 / 54	38 / 55	47 / 71	34 / –
Max. flow rate [m³/h] – 50 Hz / 60 Hz	5 / 6	7 / 7	13 / 15	20 / 24	29 / 34	48 / 55	67 / 64	78 / –
Max. pump efficiency [%]	16.5	18.5	24	24	29	30	34	34

Motors

GEA Hilge SIPLA

P2 [kW]	Frame size 4-pole							
	3.1	6.1	12.1	18.1	28.1	52.1	65.1	90.1
0.75	•							
1.5		•	•					
2.2		•	•					
3.0			•	•				
4.0				•	•			
5.5				•	•			
7.5					•	•		
11.0						•		
15.0							•	
18.5							•	•
22.0							•	•

• Available motors

Motor protection

Three-phase motors should be connected to a motor-protective circuit breaker.

All three-phase mains-operated standard motors can be connected to an external frequency converter. When a frequency converter is connected, the motor isolation is often overloaded, making the motor louder than during normal operation. In addition, large motors will be exposed to bearing currents caused by the frequency converter.

The following should be taken into account when operating a frequency converter:

- In the event of special noise protection requirements, motor noise can be reduced by using a dU/dt filter between the motor and the frequency converter. For noise-sensitive environments, we recommend using a sinus filter.
- The length of the cable between motor and frequency converter affects the motor load. For this reason, check whether the cable length corresponds to the specifications issued by the supplier of the frequency converter.
- For supply voltages between 500 and 690 V, fit either a dU/dt filter to reduce voltage peaks, or use a motor with reinforced insulation.
- For supply voltages of 690 V, use a motor with reinforced insulation, and fit a dU/dt filter.

Design

The motors are totally enclosed, fan-cooled standard motors with main dimensions according to IEC and DIN standards. Electrical tolerances according to IEC 60034.

Pump range	Design – IEC 60034-7 Horizontal installation
GEA Hilge SIPLA	IM 3001 (IM B5) IM 2001 (IM B35)

Relative air humidity: Max. 95 %

Enclosure class: IP55

Insulation class: F according to IEC 85

Ambient temperature: Max. 40 °C (standard motor)

In humid locations, the lowest drain hole in the motor must be opened. In such cases, the motor enclosure class is IP44.

Power [kW]	Motor approval		IE Class		
	CEL China Energy	INMETRO Brazil	50 Hz	60 Hz	PTC
0.75		•	3	3	
1.5	•	•	3	3	
2.2	•	•	3	3	
3.0	•	•	3	3	•
4.0	•	•	3	3	•
5.5	•	•	3	3	•
7.5	•	•	3	3	•
11.0	•	•	3	3	•
15.0	•	•	3	3	•
18.5	•	•	3	3	•
22.0	•	•	3	3	•

Selecting according to the application

The table below is intended as a general guide. Selection of connection often depends on on-site conditions.

Connection		Application																			
		Beverages					Food				Life science and personal care			Industrial applications				Cleaning			
Type		Beer	Wine	Juice	Alcohol	Soft drinks	Confectionery	Dairy products	Frying oil	Syrup	Pure water	Biotechnology products	Perfumes and lotions	Glue and paint	Purification products	Chemical products	Industrial wastewater and efflux	Surface treatment products	Biofuel	CIP	SIP
Threads	DIN 11864-1/11853-1 aseptic thread	•	•	•	•	•	•	•	•	•	•	•	•							•	•
	DIN 11851 thread	•	•	•	•	•	•	•	•	•										•	•
	SMS thread	•	•	•	•	•	•	•	•	•										•	
Flanges	DIN 11864-2 / 11853-2 aseptic flange	•	•	•	•	•	•	•	•	•	•	•								•	•
	APV-FN1/APV-FG1 flange	•	•	•	•	•	•	•	•											•	
Clamps	DIN 32676 clamp							•			•	•	•							•	•

- Commonly used connections

Design

The following tables show the design of the different connection types.

Threads

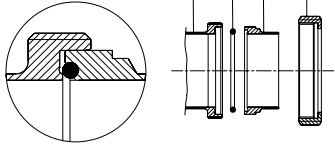
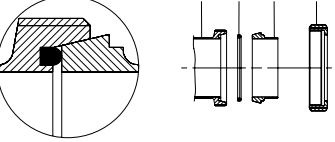
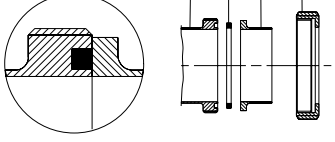
Applications	Standard	Design	Description of the components
Aseptic Thread			
<ul style="list-style-type: none"> • Biotechnology/pharmaceutical industry 	Aseptic thread DIN 11864-1/ 11853-1		0120a: Threaded connection at pump casing 0120: Threaded connection 0412: O-ring 0925: Grooved union nut
Thread			
<ul style="list-style-type: none"> • Food industry • Beverage industry 	Thread DIN 11851		0120a: Threaded connection at pump casing 0120: Threaded connection 0411: Joint ring 0925: Grooved union nut
<ul style="list-style-type: none"> • Food industry • Beverage industry 	SMS thread (DS 722)		0120a: Threaded connection at pump casing 0120: Threaded connection 0411: Joint ring 0925: Grooved union nut

Flanges

Applications	Standard	Design	Description of the components
Aseptic Flange			
<ul style="list-style-type: none"> • Biotechnology/pharmaceutical industry • Beverage industry 	DIN 11864-2/ 11853-2		0122a: Flanged connection at pump casing 0122: Flanged connection 0412: O-ring 0901: Hexagon head screw 0920: Hexagon nut
Flange			
<ul style="list-style-type: none"> • Food industry • Beverage industry 	APV-FN1/ APV-FG1		0122a: Flanged connection at pump casing 0122: Flanged connection 0410: Profile gasket 0901: Hexagon head screw 0920: Hexagon nut

Clamps

Applications	Standard	Design	Description of the components
<ul style="list-style-type: none"> • Biotechnology/pharmaceutical industry • Food industry 	DIN 32676 Range A, DIN 32676 Range B, DIN 32676 Range C		0121a: Clamp connection at pump casing 0121: Clamp connection 0410: Profile gasket 0501: Clamp ring

Shaft seals

In order to ensure correct operation (depending on the application and the medium), single mechanical or single mechanical flushed seals can be used. The mechanical seal is optimal placed inside the pump. This ensures efficient

lubrication and cooling of the mechanical seal, while also ensuring CIP (Cleaning In Place) capability. The standard material for the mechanical seals are carbon/stainless steel or SiC/SiC with EPDM or FKM (Viton) elastomers.

Mechanical seals

The operating range of the seal depends on the liquid, the type of seal, the operating pressure and the liquid temperature.

The seal types described below are standard seal types; other seals are available on request.

Version	Material	Max. system pressure	Max. temperature
Standard	Carbon / stainless steel / EPDM Carbon / stainless steel / FKM Silicon carbide/silicon carbide/EPDM Silicon carbide/silicon carbide/FKM	10 bar	-20 to 95 °C
Encapsulated spring	Carbon / stainless steel / EPDM Carbon / stainless steel / FKM Silicon carbide/silicon carbide/EPDM Silicon carbide/silicon carbide/FKM Carbon/silicon carbide/EPDM Carbon/silicon carbide/FKM	10 bar	-20 to 100 °C

Mechanical seal arrangements

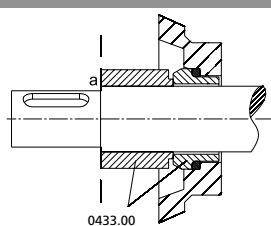
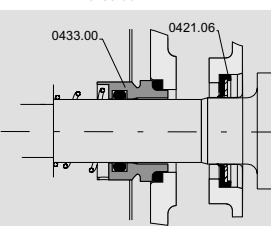
Arrangement	Design	Components	Seal characteristics	Adapta	Bloc
Single mechanical seal with encapsulated spring		0433.00: Mechanical shaft seal a: Contact surface impeller side	<ul style="list-style-type: none"> • Encapsulated spring • Easy to clean • Optimal position inside the pump • Bidirectional 	•	•
Flushed mechanical seal with quench		0433.00: Mechanical seal 0421.06: Lip seal	<ul style="list-style-type: none"> • Flushed single seal • Optimal position inside the pump • Easy to retrofit • Open or encapsulated spring possible 	•	

Mechanical installation

Never install the pump vertically!

The pumps must be installed in such a way that strain from the pipework is not transferred to the pump casing. When installed outdoors, the motor must be provided with a suitable cover to avoid condensation on the electronic components and to protect pump and motor against the direct effects of the elements.

Elimination of noise and vibrations

In order to achieve optimum operation and minimum noise and vibration, consider vibration dampening of the pump. Generally, always consider this for pumps with motors above 11 kW. Smaller motors, however, may also cause undesirable noise and vibration.

Noise and vibration are generated by the rotation in the motor and pump and by the flow in the pipework and fittings. The effect on the environment is subjective and depends on correct installation and the state of the remaining system.

Foundation

Vibration dampening is best achieved by installing the pumps on a plane and rigid concrete foundation.

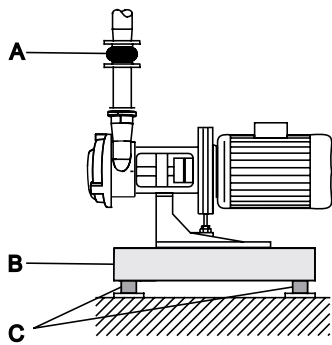

Example of a pump foundation

As a guideline, the weight of the concrete foundation should be 1.5 times the pump weight.

Vibration dampers

To prevent vibrations from being transmitted to the building, we recommend that you isolate the pump foundation from buildings by means of vibration dampers.

The selection of the correct vibration dampers requires the following data:

- Forces that will be transmitted through the vibration dampers
- Motor speed, taking speed control into account as needed
- Required dampening in % (suggested value is 70 %).

The right damper varies from installation to installation, and the wrong damper may increase the vibration level. Vibration dampers should therefore be sized by the supplier.

Space requirements

Horizontal installation

- Pumps fitted with motors up to and including 4 kW require a 300 mm clearance behind the motor.
- Pumps fitted with motors of 5.5 kW and up require at least a 1 meter clearance above the motor and 300 mm behind it to allow the use of lifting equipment.

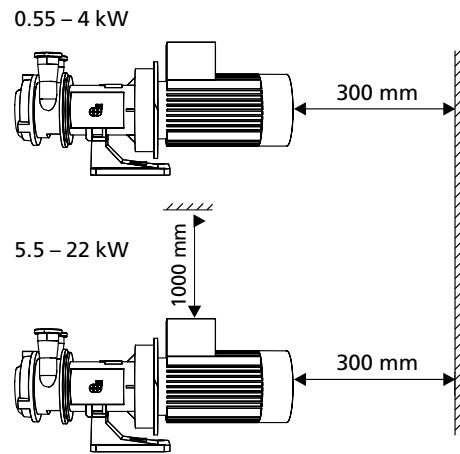

Horizontal installation

Expansion joints

If the pump is installed on a pedestal with vibration dampers, expansion joints must always be fitted on the pipeline connections. This is important to prevent the pump from "hanging" in the connections.

Install expansion joints in order to

- absorb expansion/contractions in the pipework caused by variable liquid temperatures
- reduce mechanical strains that occur in connection with pressure surges in the plant
- isolate mechanical structure-borne noise in the pipework (only rubber bellows expansion joints).

Note: Do not install expansion joints to compensate for inaccuracies in the pipework such as center displacement of flanges.

Fit expansion joints at a distance of at least 1 to 1.5 times the nominal flange diameter away from the pump on the suction as well as on the discharge side. This will prevent the development of turbulence in the expansion joints, resulting in better suction conditions and a minimum pressure loss on the discharge side.

We always recommend expansion joints with limiting rods for flanges larger than DN 100/4".

The pipes should be anchored so that they do not stress the expansion joints and the pump. Follow the supplier's instructions and pass them on to advisers or pipe installers.

The values for density and viscosity given here are ratios and can deviate in practice.

Application beer

				Mechanical seal* material product side / atmospheric side	
Subgroup	Temperature [°C]	Density [kg/m³]	Viscosity [mPas]	Single	Flushed seal
Beer	< 100	1,000	1	aeE	-
Beer mix					
Cold wort	< 40	< 1,050	< 5	aeE	-
Original wort					
Hop extract (dissolved)	< 100	< 1,050	< 5	-	kiE
Lees					
Mash (beer)					
Lauter wort	40–90	< 1,050	< 5	-	kiE
Hot wort	40–115	< 1,050	< 5	-	kiE
Crop yeast	< 20	< 1,050	< 100	aeE	-
Pitching yeast					
Yeast					
Enzymes (watery dissolution)	< 60	< 1,050	< 5	aeE	-
Lactic acid, con. < 50% (C ₃ H ₆ O ₃)	< 100	< 1,100	< 5	aeK	-
Lactic acid, con. > 50% (C ₃ H ₆ O ₃)	< 100	< 1,210	< 5	aeK	-

Application water

				Mechanical seal* material product side / atmospheric side	
Subgroup	Temperature [°C]	Density [kg/m³]	Viscosity [mPas]	Single	Flushed seal
Iced water	-4 to +3	< 1,000	1	kiE	-
Cold water	< 110	< 1,000	1	aeE	-
Demineralized water (Not for sterile applications)					
Drinking water					
Flushing water					
Hot water					
Mineral water					
Process water					
Service water					
Water					

Application wine/sparkling wine

				Mechanical seal* material product side / atmospheric side						
Subgroup	Temperature [°C]	Density [kg/m³]	Viscosity [mPas]	Single	Flushed seal					
Champagne	< 35	< 1,000	1	aeE	-					
Cider										
Cidre										
Prosecco										
Sparkling wine										
Strawberry wine										
Wine	< 35	< 1,050	15	aeE	-					
Grape must (w/o. particles)										
Wine lees						< 35	< 1,050	100	kiE	-
Wine yeast						< 35	< 1,050	100	aeE	-
Mash (wine) (w/o. particles)	< 35	< 1,050	5	kiE	-					

Application coffee/tea/cocoa

Subgroup	Temperature [°C]	Density [kg/m³]	Viscosity [mPas]	Mechanical seal* material product side / atmospheric side		
				Single	Flushed seal	Encapsulated seal for vacuum application
Coffee	< 125	1,000	1	aeE	–	
Coffee extract	< 80–100	< 1,200	< 250	–	–	x
Tea	< 125	1,000	1	aeE	–	
Fruit tea / flavored tea	< 125	1,000	1	aeE	–	
Cocoa drink	< 40	1,020	< 10	aeE	–	

Application vinegar/sauces/marinade

Subgroup	Temperature [°C]	Density [kg/m³]	Viscosity [mPas]	Mechanical seal* material product side / atmospheric side	
				Single	Flushed seal
Soy sauce	5–95	1,250	25	kiE	–
	95.1–125	1,250	25	–	kiE
Vinegar	60	1,020	1	aeE	–
Vinegar essence	60	1,050	1	aeV	–

Application non-alcoholic drink

Subgroup	Temperature [°C]	Density [kg/m³]	Viscosity [mPas]	Mechanical seal* material product side / atmospheric side		
				Single	Flushed seal	Encapsulated seal
Cola	< 100	1,040	< 5	aeE	–	
Concentrated lemon juice, without pulp and granules	< 70	1,060	25	kiV	–	
Fruit juice, with granules	< 70	1,040	< 50	kiE	–	x
Fruit juice, with pulp	< 70	1,040	< 50	kiV	–	x
Fruit juice, with pulp and with granules	> 70 – < 95	1,040	< 10	–	kiE	x
Fruit juice, without pulp	< 70	1,040	< 50	aeE	–	
	> 70 – < 95	1,040	< 10	–	kiE	
Grape juice	< 70	1,040	< 50	aeE	–	
	> 70 – < 95	1,040	< 10	–	kiE	
Iced tea	< 100	1,040	< 5	aeE	–	
Lemon juice, with pulp and granules	< 70	1,040	25	kiV	–	x
Lemon juice, without pulp and granules	< 70	1,040	25	aeV	–	
Lemonade	< 100	1,040	< 5	aeE	–	
Vegetable juice, with pulp and granules	< 70	1,050	< 50	kiV	–	x
	> 70 – < 95	1,050	< 10	–	–	x
Vegetable juice, without pulp and granules	< 70	1,050	< 50	aeV	–	
	> 70 – < 95	1,050	< 10	–	–	

* aeE: carbon/stainless steel/EPDM, aeV: carbon/stainless steel/Viton, kiE: SIC/SIC/EPDM, kiV: SIC/SIC/Viton. The elastomer of the static seals equals the elastomer of the mechanical seals.

Application milk

Subgroup	Temperature [°C]	Density [kg/m³]	Viscosity [mPas]	Mechanical seal* material product side / atmospheric side	
				Single	Flushed seal
Buttermilk	< 55	< 1,050	< 10	aeE	-
	> 55 – < 100	< 1,050	< 5	-	aeE
UHT milk	< 55	< 1,050	< 10	aeE	-
	> 55 – < 100	< 1,050	< 5	-	aeE
Yoghurt milk	< 55	< 1,050	< 10	aeE	-
	> 55 – < 100	< 1,050	< 5	-	aeE
Kefir	< 55	< 1,050	< 10	aeE	-
	> 55 – < 100	< 1,050	< 5	-	aeE
Cheese milk	< 55	< 1,050	< 10	aeE	-
	> 55 – < 100	< 1,050	< 5	-	aeE
Skimmed milk	< 55	< 1,050	< 10	aeE	-
	> 55 – < 100	< 1,050	< 5	-	aeE
Skimmed milk concentrate	< 55	< 1,050	< 10	aeE	-
	> 55 – < 100	< 1,050	< 5	-	aeE
Milk	< 55	< 1,050	< 10	aeE	-
	> 55 – < 100	< 1,050	< 5	-	aeE
Milk concentrate	< 55	< 1,050	< 10	aeE	-
	> 55 – < 100	< 1,050	< 5	-	aeE
Lactic culture	< 55	< 1,050	< 10	aeE	-
	> 55 – < 100	< 1,050	< 5	-	aeE
Milk mix	< 55	< 1,050	< 10	aeE	-
	> 55 – < 100	< 1,050	< 5	-	aeE
Whey	< 55	< 1,050	< 10	aeE	-
	> 55 – < 100	< 1,050	< 5	-	aeE
Raw milk	< 55	< 1,050	< 10	aeE	-
	> 55 – < 100	< 1,050	< 5	-	aeE
Pre-stirred yoghurt	< 55	< 1,050	< 10	aeE	-
	> 55 – < 100	< 1,050	< 5	-	aeE
Sour milk	< 55	< 1,050	< 10	aeE	-
	> 55 – < 100	< 1,050	< 5	-	aeE
Sour cream with thickening agents	< 55	< 1,050	< 10	aeE	-
	> 55 – < 100	< 1,050	< 5	-	aeV
Full cream milk	< 55	< 1,050	< 10	aeE	-
	> 55 – < 100	< 1,050	< 5	-	aeV
Coffee cream	< 55	< 1,100	< 40	aeV	-
	> 55 – < 100	< 1,100	< 20	-	aeV
Whipping cream	< 55	< 1,100	< 40	aeV	-
	> 55 – < 100	< 1,100	< 20	-	aeV
Sour cream	< 55	< 1,100	< 40	aeV	-
	> 55 – < 100	< 1,100	< 20	-	aeV
Cream	< 55	< 1,100	< 40	aeV	-
	> 55 – < 100	< 1,100	< 20	-	aeV
Condensed milk	< 55	< 1,100	< 40	aeV	-
	> 55 – < 100	< 1,100	< 20	-	aeV

Application spirits

Subgroup	Temperature [°C]	Density [kg/m³]	Viscosity [mPas]	Concentration [%]	Mechanical seal* material product side / atmospheric side	
					Single	Flushed seal
Spirits	40	< 1,000	< 5		aeE	-
	< 50	< 1,150	< 150		-	aeE
	< 100	< 1,150	< 100		-	aeE
	< 78	< 1,000	1	< 10	aeE	-
	< 78	900	1	< 50	aeE	-
	< 78	800	1	< 98	aeE	-

Application oil

				Mechanical seal* material product side / atmospheric side	
Subgroup	Temperature [°C]	Density [kg/m³]	Viscosity [mPas]	Single	
Vegetable oil	10–30	940	< 80	aeV	
	30.1–125	920	< 40	aeV	
Chip fat	< 170	900	10		
Butter oil (liquid)	> 45–120	860	45	aeV	
Lard (liquid)	> 45–120	860	45	aeV	
Liquid butter	> 35–120	860	45	aeV	
Fish oil	10–125	950	< 100	aeV	
Whale oil	10–125	950	< 100	aeV	
Cod liver (cod-liver oil)	10–125	950	< 100	aeV	
Mineral oil					
Motor oil	10–100			aeV	
Petroleum					
Derv					
Diesel oil	10–100	850	< 15	aeV	
Oil-in-water emulsion	0–100	1,000	< 50	aeV	

Application concentrated fruit juice

					Mechanical seal* material product side / atmospheric side	
Subgroup	Temperature [°C]	Density [kg/m³]	Viscosity [mPas]	Concentration [Brix]	Single	Flushed seal
Concentrated fruit juice	5–90	1,150	related to temperature	to 25°	aeE	–
	5–40	1,200		26–49°	aeE	–
	40.1–90	1,200		26–49°	–	aeE
	15–40	1,230		50°	aeE	–
	40.1–90	1,230		50°	–	aeE
	15–40	1,260		55°	aeE	–
	40.1–90	1,260		55°	–	aeE
	15–40	1,290		60°	aeE	–
	40.1–90	1,290		60°	–	aeE
	15–40	1,320		65°	aeE	–
	40.1–90	1,320		65°	–	aeE
	20–40	1,350		70°	aeE	–
	40.1–90	1,350		70°	–	aeE

Application cleaning in place CIP

					Mechanical seal* material product side / atmospheric side	
Subgroup	Temperature [°C]	Density [kg/m³]	Viscosity [mPas]	Concentration [%]	Single	Flushed seal
CIP liquid (concentration approx. 5%)	< 100	1,050	< 5	< 5	aeE	–

* aeE: carbon/stainless steel/EPDM, aeV: carbon/stainless steel/Viton. The elastomer of the static seals equals the elastomer of the mechanical seals.

Application chemicals

Subgroup	Temperature [°C]	Density [kg/m³]	Viscosity [mPas]	Concentration [%]	Mechanical seal* material product side / atmospheric side	
					Single	Flushed seal
Caustic soda (NaOH)	< 60	= Concentration		< 15	kiE	-
	< 60	= Concentration		> 15 - < 50	-	-
	> 60 - < 101	= Concentration		< 12	kiE	-
	> 60 - < 101	= Concentration		< 12 - < 50	-	kiE
Peracetic / peroxyacetic (C ₂ O ₃)	< 60	< 1,020	< 1	< 5	kiV	-
	< 60	< 1,060	< 5	> 5.1 - < 15	SIC/SIC/Kalrez	-
Phosphoric acid (H ₃ PO ₄)	< 40	1 % = 1,004 5 % = 1,026	< 5	< 15	kiV	-
	> 40 - < 85	10 % = 1,053 20 % = 1,114	< 5	< 15	-	kiV
	< 85	35 % = 1,216 45 % = 1,293	< 5	> 15 - < 45	-	-
Nitric acid (HNO ₃)	0-20	1 % = 1,004 10 % = 1,055	5	0-10	kiV	-
	20.1-40		5	0-10	-	kiV
	0-40	20 % = 1,115	5	10.1-20	-	kiV
	40.1-85	30 % = 1,180	5	0-20	-	-
	0-85	40 % = 1,245	5	20.1-40	-	-
Sulfuric acid (H ₂ SO ₄)	< 20	< 1,1	< 25	< 12	-	-
	< 70	< 1,08	< 20	< 12	-	-
High test peroxide (H ₂ O ₂) Hydrogen peroxide	< 90	< 1,050	2	2-3	aeV	-
	< 90	< 1,150	2	< 40	kiV	-
	< 90	< 1,300	2	< 60	kiV	-
	< 60	< 1,450	2	< 100	-	-
Brine solution Common salt solution Sodium chloride (NaCl)	< 30	< 1,050	< 5	< 5	aeE	-
	30.1-40	< 1,050	< 5	< 5	kiE	-
	< 40	< 1,080	< 5	5.1-10	kiE	-
	< 40	< 1,200	< 25	10.1-25	-	kiE
Curing brine (butchery)	< 40	1,200	< 300	< 20	kiE	-
Salting brine (cheese dairy)	< 40	1,300	< 60	20-30	-	-
Ammonia/ammoniac (NH ₃)	< 40	800	< 5		-	-
Caustic potash (KOH)	< 60	< 1,100	< 5	< 10	kiE	-
Potassium hydroxide	< 60	< 1,200	< 5	20	kiE	-
Glycerol Propanetriol	80	< 1,100	< 5	0-40	aeV	-
Propylene-glycol (C ₃ H ₈ O ₂)	0-80	1,010	< 5	1-20	kiV	-
	-5-80	1,020	< 20	20.1-50	kiV	-
	-10-80	1,040	< 150	50.1-75	kiV	-
	-10-0	1,060	< 255	75.1-100	kiV	-
	0.1-80	1,050	< 150	75.1-100	kiV	-
Ethanediol Ethylene-glycol (C ₂ H ₆ O ₂)	0-80	1,030	< 5	1-20	kiE	-
	-5-80	1,060	< 20	20.1-50	kiE	-
	-10-80	1,090	< 40	50.1-75	kiE	-
	-10-0	1,120	< 100	75.1-100	kiE	-
	0.1-80	1,110	< 65	75.1-100	kiE	-
Citric acid (C ₆ H ₈ O ₇) Natural citric acid	5-80	1 % = 1,005 10 % = 1,020	< 15	< 10	kiV	-
	5-80	10.1 % = 1,020 20 % = 1,050 30 % = 1,100 50 % = 1,260	< 15	10.1-50	kiV	-
Acetic acid (C ₂ H ₄ O ₂)	5-80	1,010	1	< 10	aeE	-
	5-100	1,050	1	10.1-100	-	-

Application sugar syrup

					Mechanical seal* material product side / atmospheric side	
Subgroup	Temperature [°C]	Density [kg/m³]	Viscosity [mPas]	Concentration [Brix]	Single	Flushed seal
Sugar syrup without crystals	5-90	1,150	related to temperature	to 25°	aeE	-
	5-40	1,200		26-49°	aeE	-
	40.1-90	1,200		26-49°	-	aeE
	15-40	1,230		50°	aeE	-
	40.1-90	1,230		50°	-	aeE
	15-40	1,260		55°	aeE	-
	40.1-90	1,260		55°	-	aeE
	15-40	1,290		60°	aeE	-
	40.1-90	1,290		60°	-	aeE
	15-40	1,320		65°	aeE	-
	40.1-90	1,320		65°	-	aeE
	20-40	1,350		70°	aeE	-
	40.1-90	1,350		70°	-	aeE
	20-40	1,360		72,7°	aeE	-
	40.1-90	1,360		72,7°	-	aeE
	5-90	1,150		to 25°	kiE	-
	5-40	1,200		26-49°	kiE	-
	40.1-90	1,200		26-49°	-	aeE
	15-40	1,230		50°	kiE	-
	40.1-90	1,230		50°	-	kiE
	15-40	1,260		55°	kiE	-
	40.1-90	1,260		55°	-	kiE
	15-40	1,290		60°	kiE	-
	40.1-90	1,290		60°	-	kiE
	15-40	1,320		65°	kiE	-
	40.1-90	1,320		65°	-	kiE
	20-40	1,350		70°	kiE	-
	40.1-90	1,350		70°	-	kiE

* aeE: carbon/stainless steel/EPDM, aeV: carbon/stainless steel/Viton, kiE: SiC/SiC/EPDM, kiV: SiC/SiC/Viton, kiH: SiC/SiC/EPDM (USP-Class VI), ooH: SiC/SiC/EPDM (USP-Class VI), kiK: SiC/SiC/Kalrez. The elastomer of the static seals equals the elastomer of the mechanical seals.



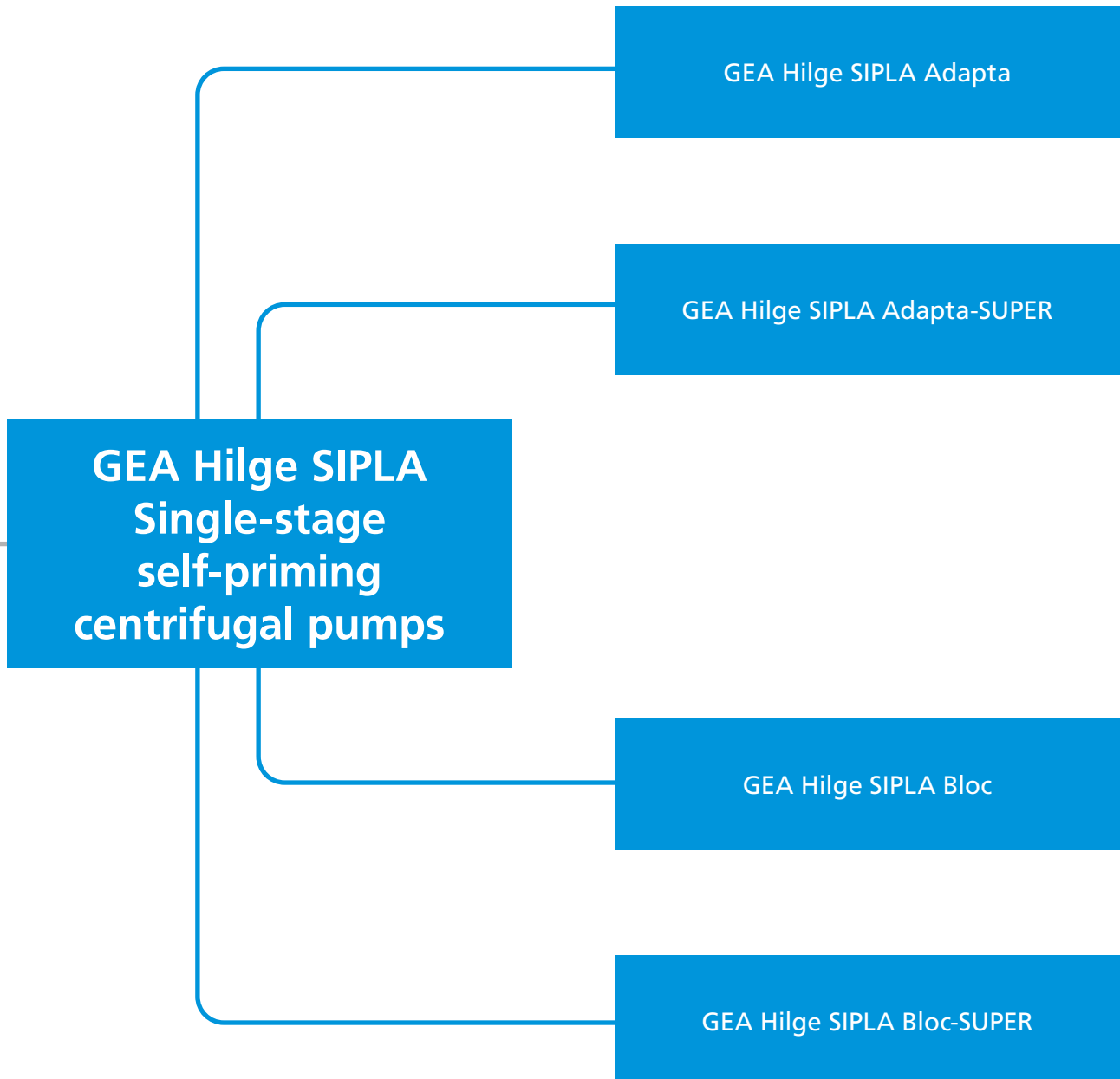



Technical data of the standard version	
Materials	Pump housing: stainless steel 316L (1.4404) Impeller: precision casting 316L (1.4404)
Connections	Thread DIN 11851
Mechanical seal	Single mechanical seal, material carbon/stainless steel/EPDM (FDA, USP Class VI)
Static seals	EPDM (FDA, USP Class VI)
Motor	Standard motor: IEC Motor, 3 × 380/400/415 V/50 Hz, IP 55, ISO-Class F, incl. PTC thermistor, IE3
Documentation	Operating instructions, declaration of conformity, pump test report
Flow rate 50 Hz	Max. 48 m³/h
Flow rate 60 Hz	Max. 54 m³/h
Pump head 50 Hz	Max. 38 m
Pump head 60 Hz	Max. 42 m
Housing pressure	10 bar
Certificates	

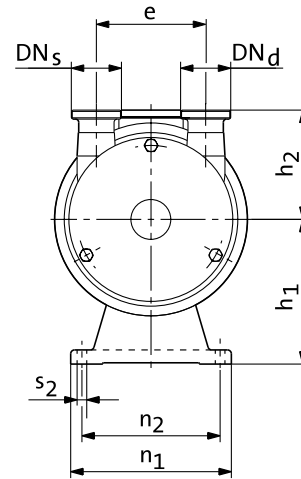
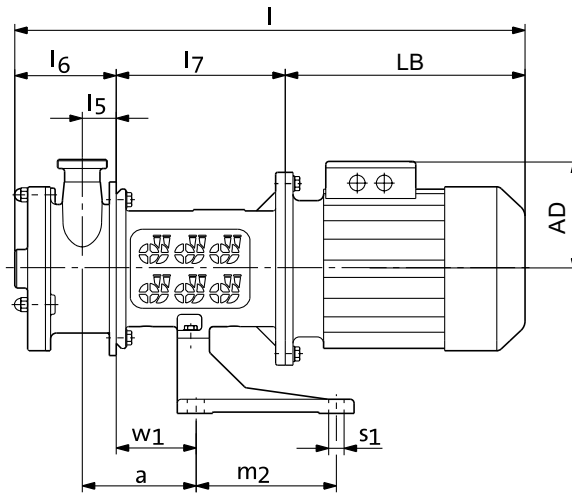

m₂ = 220 mm
n₁ = 250 mm
n₂ = 215 mm
s₁/s₂ = 24/14 mm

4-pole

Pump type	P2 [kW]	IEC-size	DN _s /DN _d	a [mm]	l [mm]	e [mm]	l ₅ [mm]	l ₆ [mm]	l ₇ [mm]	LB [mm]	AD [mm]	w ₁ [mm]	h ₁ [mm]	h ₂ [mm]
3.1	0.75	80M	32	146	648	100	40	107	221	320	130	106	200	150
6.1/12.1	1.5	90L	40	162	698	120	56	137	221	340	140	106	200	150
	2.2	100L	40	162	748	120	56	137	241	370	175	106	200	150
18.1	3.0	100L	50	176	791	170	53	158	263	370	175	123	225	170
	4.0	112M	50	176	801	170	53	158	263	380	185	123	225	170
	5.5	132S	50	176	871	170	53	158	263	450	205	123	225	170
28.1	4.0	112M	65	178	808	170	55	165	263	380	185	123	225	170
	5.5	132S	65	178	898	170	55	165	283	450	205	123	225	170
	7.5	132M	65	178	898	170	55	165	283	450	205	123	225	170
52.1	7.5	132M	65	179	911	170	56	178	283	450	205	123	225	200
	11.0	160M	65	179	1,062	170	56	178	314	570	260	123	225	200

Motor dimensions depend on the motor manufacturer and execution. The shown motor dimensions indicate the size for the standard motor.
Flushing connection only for quenched version.
Weight: net-weight without packaging.



Technical data of the standard version	
Materials	Pump housing: stainless steel 316L (1.4404) Impeller: precision casting 316L (1.4404)
Connections	Thread DIN 11851
Mechanical seal	Single mechanical seal, material carbon/stainless steel/EPDM (FDA, USP Class VI)
Static seals	EPDM (FDA, USP Class VI)
Motor	Standard motor: IEC Motor, 3 × 380/400/415 V/50 Hz, IP 55, ISO-Class F, incl. PTC thermistor, IE3
Documentation	Operating instructions, declaration of conformity, pump test report
Flow rate 50 Hz	Max. 78 m³/h
Flow rate 60 Hz	Max. 64 m³/h
Pump head 50 Hz	Max. 47 m
Pump head 60 Hz	Max. 60 m
Housing pressure	10 bar
Certificates	

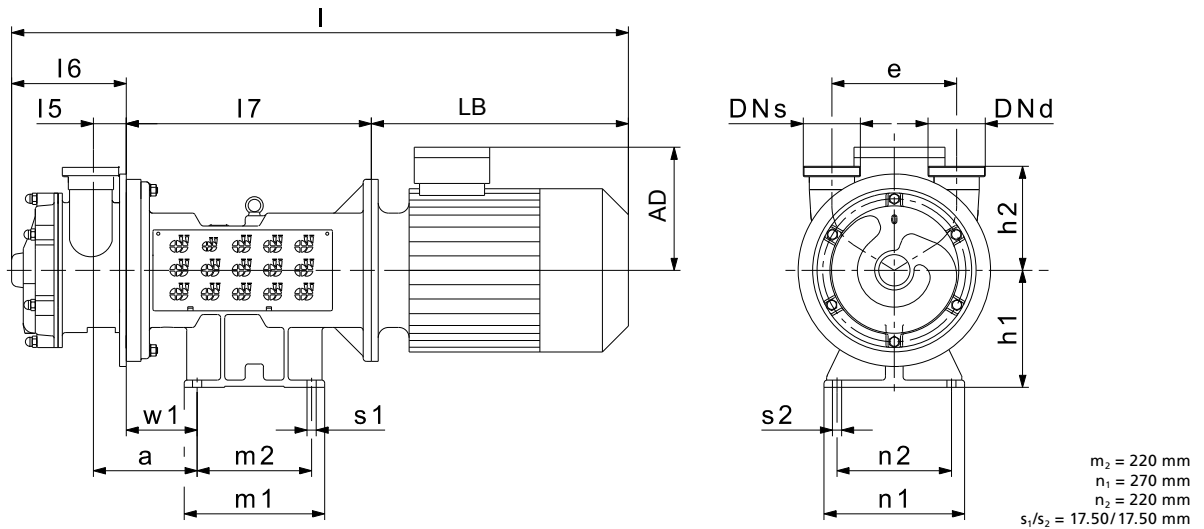

4-pole

Pump type	P2 [kW]	IEC-size	DNs/ DNd	a [mm]	l [mm]	e [mm]	l ₅ [mm]	l ₆ [mm]	l ₇ [mm]	LB [mm]	AB [mm]	w ₁ [mm]	h ₁ [mm]	h ₂ [mm]
65.1	15.0	160L	80	204	1,271	240	68	220	471	580	260	136	225	200
	18.5	180M	80	204	1,311	240	68	220	471	620	290	136	225	200
	22.0	180L	80	204	1,311	240	68	220	471	620	290	136	225	200
90.1	18.5	180M	80	204	1,317	240	68	226	471	620	290	136	225	200
	22.0	180L	80	204	1,317	240	68	226	471	620	290	136	225	200

Motor dimensions depend on the motor manufacturer and execution. The shown motor dimensions indicate the size for the standard motor.
 Flushing connection only for quenched version.
 Weight: net-weight without packaging.



Technical data of the standard version	
Materials	Pump housing: stainless steel 316L (1.4404) Impeller: precision casting 316L (1.4404)
Connections	Thread DIN 11851
Mechanical seal	Single mechanical seal, material carbon/stainless steel/EPDM (FDA, USP Class VI)
Static seals	EPDM (FDA, USP Class VI)
Motor	Standard motor: IEC Motor, 3 × 380/400/415 V/50 Hz, IP 55, ISO-Class F, incl. PTC thermistor, IE3
Documentation	Operating instructions, declaration of conformity, pump test report
Flow rate 50 Hz	Max. 48 m³/h
Flow rate 60 Hz	Max. 54 m³/h
Pump head 50 Hz	Max. 38 m
Pump head 60 Hz	Max. 42 m
Housing pressure	10 bar
Certificates	

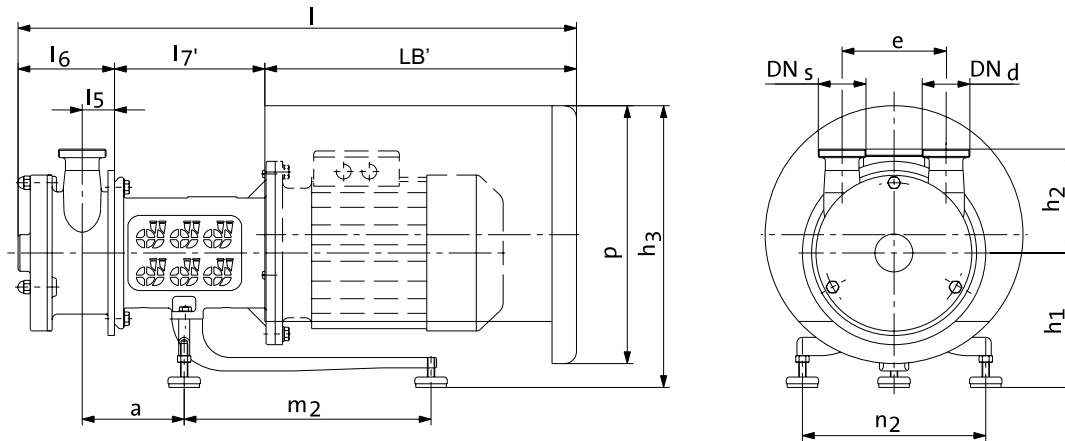

4-pole

Pump type	P2 [kW]	IEC-size	DNs/ DNd	a [mm]	l [mm]	h ₁ [mm]	h ₂ [mm]	h ₃ [mm]	e [mm]	l ₅ [mm]	l ₆ [mm]	l ₇ [mm]	m ₂ [mm]	n ₂ [mm]	p [mm]	LB [mm]
3.1	0.75	80M	32	138	654	200	150	380	100	40	107	204	300	260	320	410
6.1/12.1	1.5	90L	40	154	670	200	150	380	120	56	137	204	300	260	320	410
	2.2	100L	40	154	720	200	150	410	120	56	137	204	404	300	370	460
18.1	3.0	100L	50	168	809	220	170	460	170	53	158	246	404	300	420	510
	4.0	112M	50	168	809	220	170	460	170	53	158	246	404	300	420	510
	5.5	132S	50	168	809	220	170	460	170	53	158	246	404	300	420	510
28.1	4.0	112M	65	170	811	220	170	460	170	55	165	246	404	300	420	510
	5.5	132S	65	170	811	220	170	460	170	55	165	246	404	300	420	510
	7.5	132M	65	170	811	220	170	460	170	55	165	246	404	300	420	510
52.1	7.5	132M	65	171	812	220	200	460	170	56	178	246	404	300	420	510
	11.0	160M	65	171	951	220	200	503	170	56	178	245	404	300	485	650

Motor dimensions depend on the motor manufacturer and execution. The shown motor dimensions indicate the size for the standard motor.
 Flushing connection only for quenched version.
 Weight: net-weight without packaging.



Technical data of the standard version	
Materials	Pump housing: stainless steel 316L (1.4404) Impeller: precision casting 316L (1.4404)
Connections	Thread DIN 11851
Mechanical seal	Single mechanical seal, material carbon/stainless steel/EPDM (FDA, USP Class VI)
Static seals	EPDM (FDA, USP Class VI)
Motor	Standard motor: IEC Motor, 3 × 380/400/415 V/50 Hz, IP 55, ISO-Class F, incl. PTC thermistor, IE3
Documentation	Operating instructions, declaration of conformity, pump test report
Flow rate 50 Hz	Max. 78 m ³ /h
Flow rate 60 Hz	Max. 64 m ³ /h
Pump head 50 Hz	Max. 47 m
Pump head 60 Hz	Max. 60 m
Housing pressure	10 bar
Certificates	

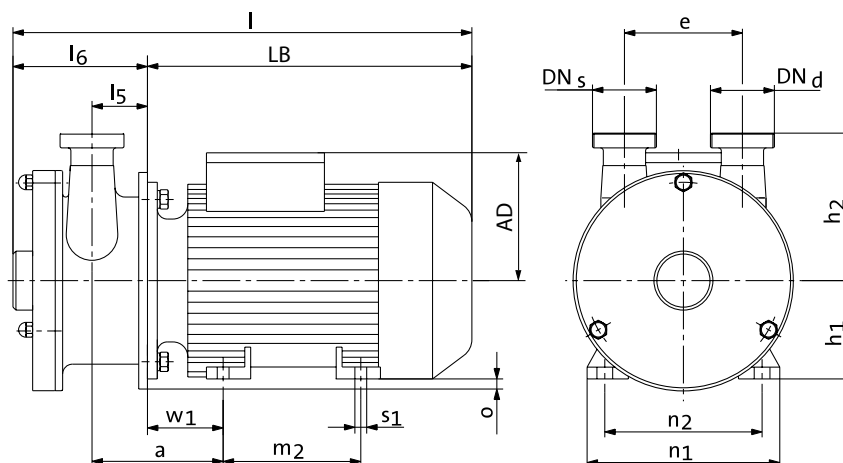

4-pole

Pump type	P2 [kW]	IEC-size	DN _s /DN _d	a [mm]	l [mm]	o [mm]	h ₂ [mm]	e [mm]	l ₅ [mm]	l ₆ [mm]	h ₁ [mm]	LB [mm]	m ₂ [mm]	n ₁ [mm]	n ₂ [mm]	s ₁ [mm]	w ₁ [mm]	AD [mm]
3.1	0.75	80M	32	90	339	30	150	100	40	107	80	232	100	157	125	9.5	50	139
6.1/12.1	1.5	100L	40	135	443	10	150	120	57	137	100	306	140	192	160	12.0	78	154
	2.2	100L	40	135	443	10	150	120	57	137	100	306	140	192	160	12.0	78	154
18.1	3.0	100L	50	116	495	35	170	170	53	158	100	337	140	192	160	12.0	63	154
	4.0	112M	50	123	486	23	170	170	53	158	112	328	140	220	190	12.0	70	171
	5.5	132S	50	162	583	3	170	170	53	158	132	425	140	256	216	12.0	109	194
28.1	4.0	112M	65	125	493	23	170	170	55	165	112	328	140	220	190	12.0	70	171
	5.5	132S	65	164	590	3	170	170	55	165	132	425	140	256	216	12.0	109	194
	7.5	132M	65	164	610	3	170	170	55	165	132	445	178	256	216	12.0	109	194
52.1	7.5	132M	65	145	583	28	200	170	56	178	132	405	404	256	216	12.0	89	194
65.1	15.0	160L	80	188	749	25	200	240	68	220	160	529	254	320	254	15.0	120	222
	18.5	160L	80	188	749	25	200	240	68	220	160	529	254	320	254	15.0	120	222
90.1	18.5	160L	80	188	755	25	200	240	68	226	160	529	254	320	254	15.0	120	222

Motor dimensions depend on the motor manufacturer and execution. The shown motor dimensions indicate the size for the standard motor.
Flushing connection only for quenched version.
Weight: net-weight without packaging.



Technical data of the standard version	
Materials	Pump housing: stainless steel 316L (1.4404) Impeller: precision casting 316L (1.4404)
Connections	Thread DIN 11851
Mechanical seal	Single mechanical seal, material carbon/stainless steel/EPDM (FDA, USP Class VI)
Static seals	EPDM (FDA, USP Class VI)
Motor	Standard motor: IEC Motor, 3 × 380/400/415 V/50 Hz, IP 55, ISO-Class F, incl. PTC thermistor, IE3
Documentation	Operating instructions, declaration of conformity, pump test report
Flow rate 50 Hz	Max. 48 m³/h
Flow rate 60 Hz	Max. 54 m³/h
Pump head 50 Hz	Max. 38 m
Pump head 60 Hz	Max. 42 m
Housing pressure	10 bar
Certificates	

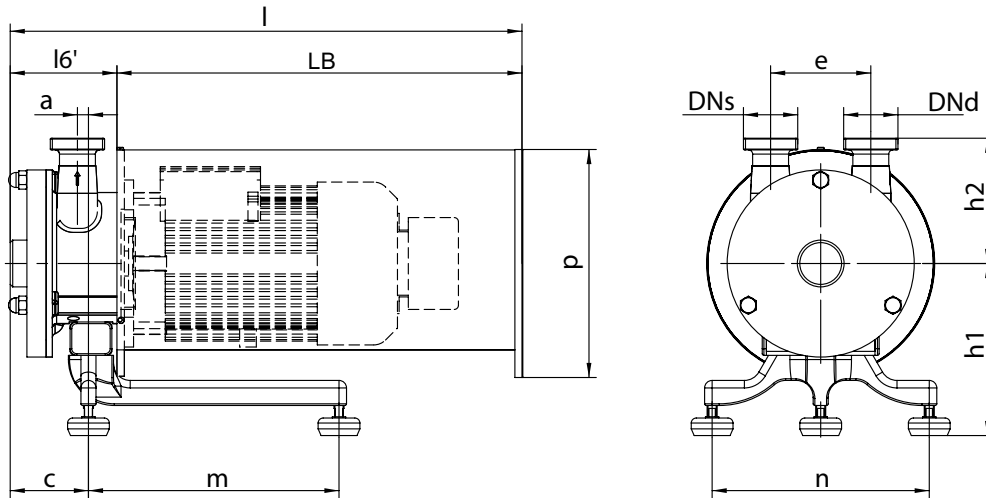

4-pole

Pump type	P2 [kW]	IEC-size	DNs/ DNd	h ₁ [mm]	h ₂ [mm]	l [mm]	n [mm]	m [mm]	e [mm]	l ₆ [mm]	a [mm]	c [mm]	P [mm]	LB [mm]
6.1/12.1	1.5	100L	40	208	150	607	260	300	120	127	13	94	270	550
	2.2	100L	40	208	150	607	260	300	120	127	13	94	270	550
18.1	3.0	100L	50	223	170	667	260	300	170	147	10	115	270	550
	4.0	112M	50	223	170	667	260	300	170	147	10	115	270	550
	5.5	132S	50	223	170	747	260	300	170	147	10	115	320	640
28.1	4.0	112M	65	223	170	674	260	300	170	154	13	122	270	550
	5.5	132S	65	223	170	754	260	300	170	154	13	122	320	640
	7.5	132M	65	223	170	754	260	300	170	154	13	122	320	640
52.1	7.5	132M	65	223	200	768	260	300	170	168	14	136	320	640

Motor dimensions depend on the motor manufacturer and execution. The shown motor dimensions indicate the size for the standard motor.
 Flushing connection only for quenched version.
 Weight: net-weight without packaging.



Technical data of the standard version	
Materials	Pump housing: stainless steel 316L (1.4404) Impeller: precision casting 316L (1.4404)
Connections	Thread DIN 11851
Nominal width of connections	Suction side DN 32–80, pressure side DN 32–80
Mechanical seal	Single mechanical seal, material carbon/stainless steel/EPDM (FDA, USP Class VI)
Static seals	EPDM (FDA, USP Class VI)
Motor	Standard motor: IEC Motor, 3 × 380/400/415 V/50 Hz, IP 55, ISO-Class F, incl. PTC thermistor, IE3
Documentation	Operating instructions, declaration of conformity, pump test report
Flow rate 50 Hz	Max. 78 m³/h
Flow rate 60 Hz	Max. 64 m³/h
Pump head 50 Hz	Max. 47 m
Pump head 60 Hz	Max. 60 m
Housing pressure	10 bar
Certificates	

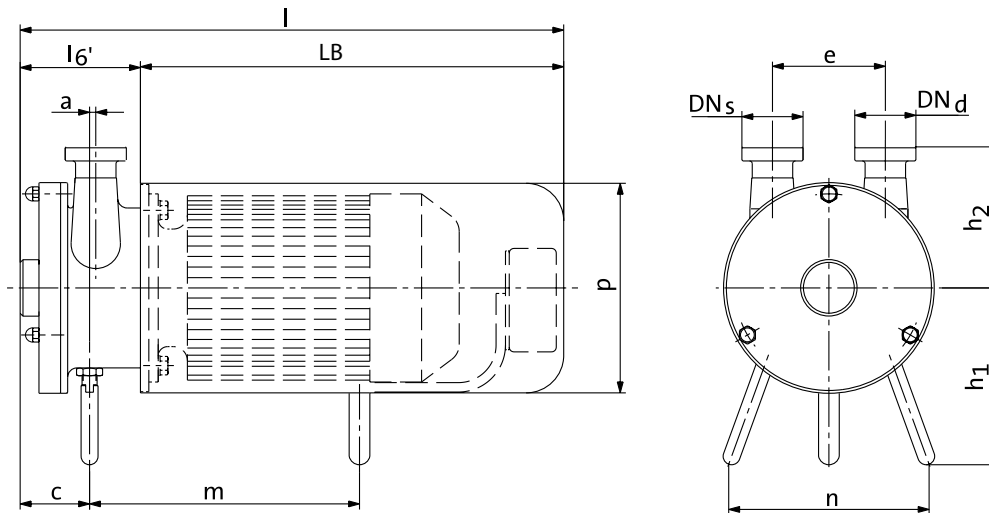

4-pole

Pump type	P2 [kW]	IEC-size	DNs/ DNd	h_1 [mm]	h_2 [mm]	l [mm]	n [mm]	m [mm]	e [mm]	l_6 [mm]	a [mm]	c [mm]	p [mm]	LB [mm]
3.1	0.75	80M	32	155	150	97	205	220	100	97	0	68	220	450
65.1	15.0	160L	80	200	200	908	229	397	240	208	21	131	370	700
	18.5	160L	80	200	200	908	229	397	240	208	21	131	370	700
90.1	18.5	160L	80	200	200	914	229	397	240	214	21	137	370	700
	22.0	160L	80	200	200	914	229	397	240	214	21	137	370	700

Motor dimensions depend on the motor manufacturer and execution. The shown motor dimensions indicate the size for the standard motor.
 Flushing connection only for quenched version.
 Weight: net-weight without packaging.

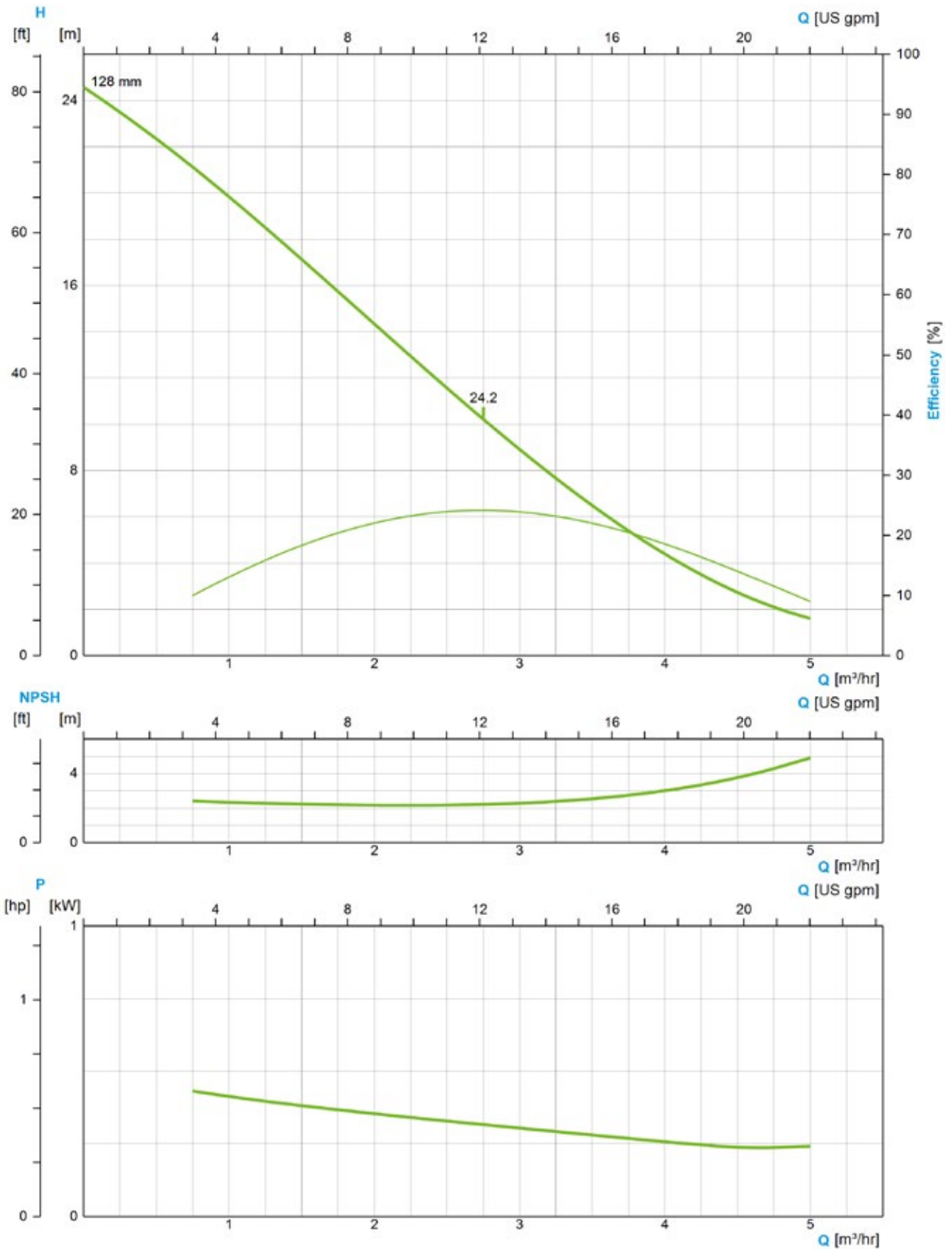

The flow charts are based on water, temperature 20 °C

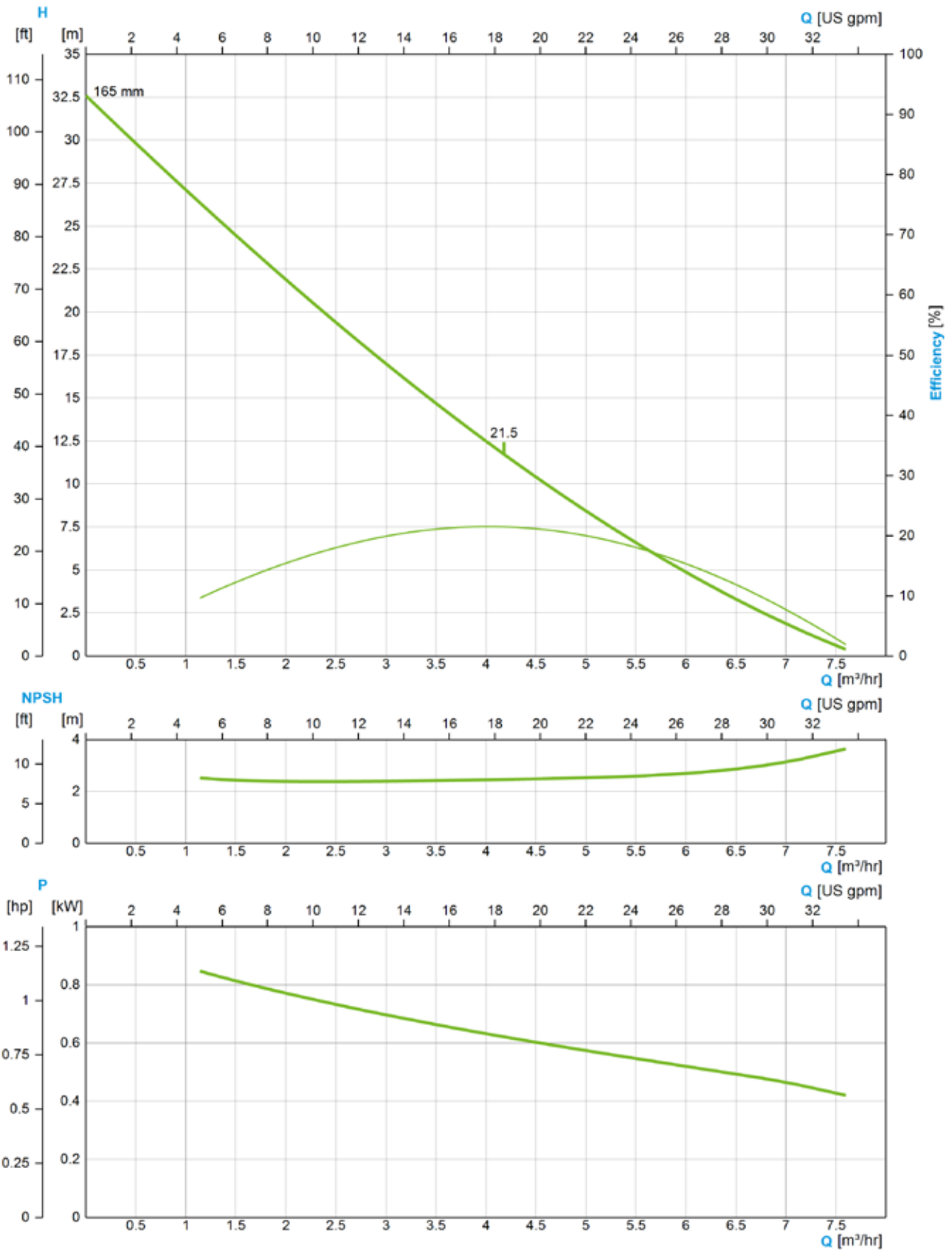

The flow charts are based on water, temperature 20 °C

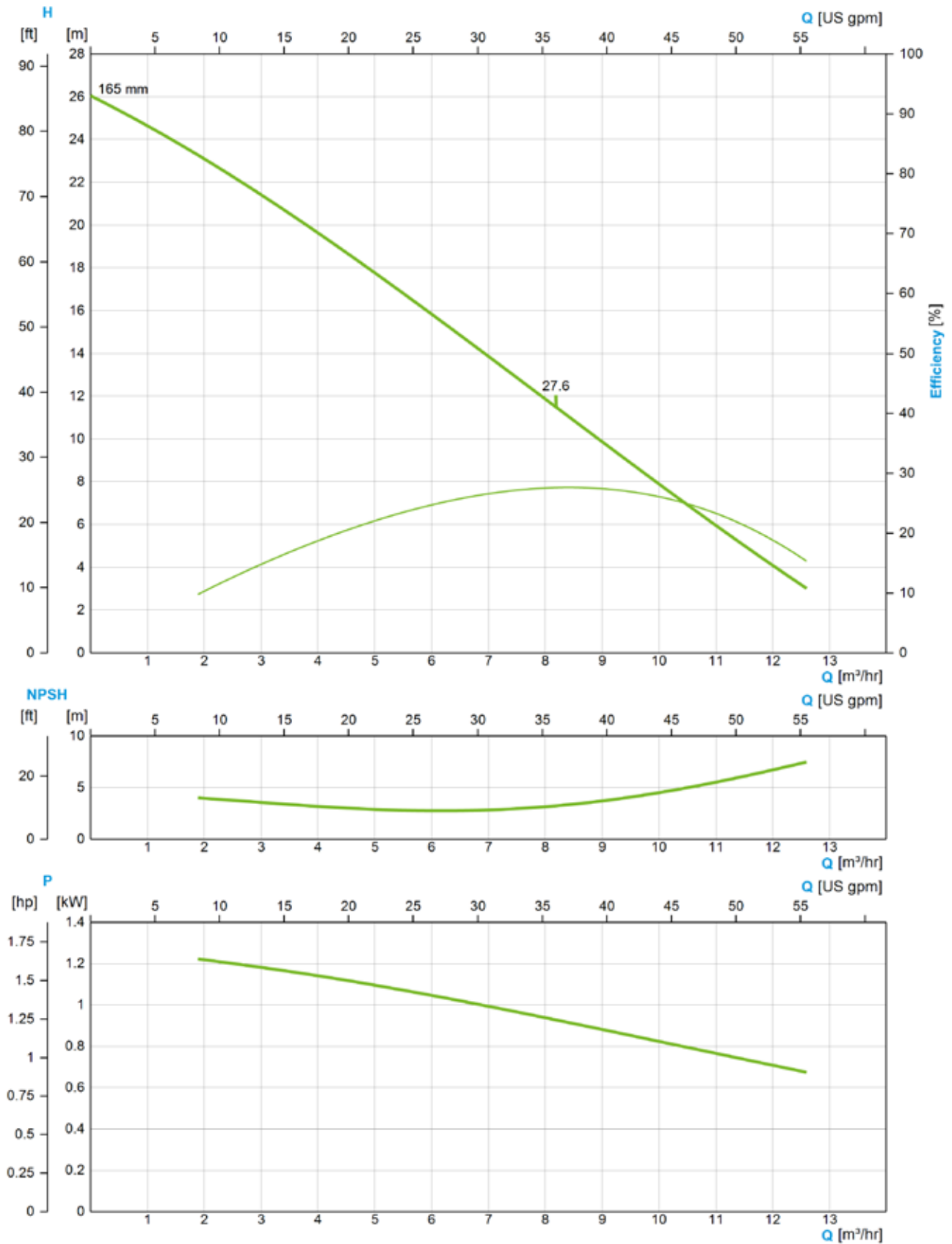

The flow charts are based on water, temperature 20 °C

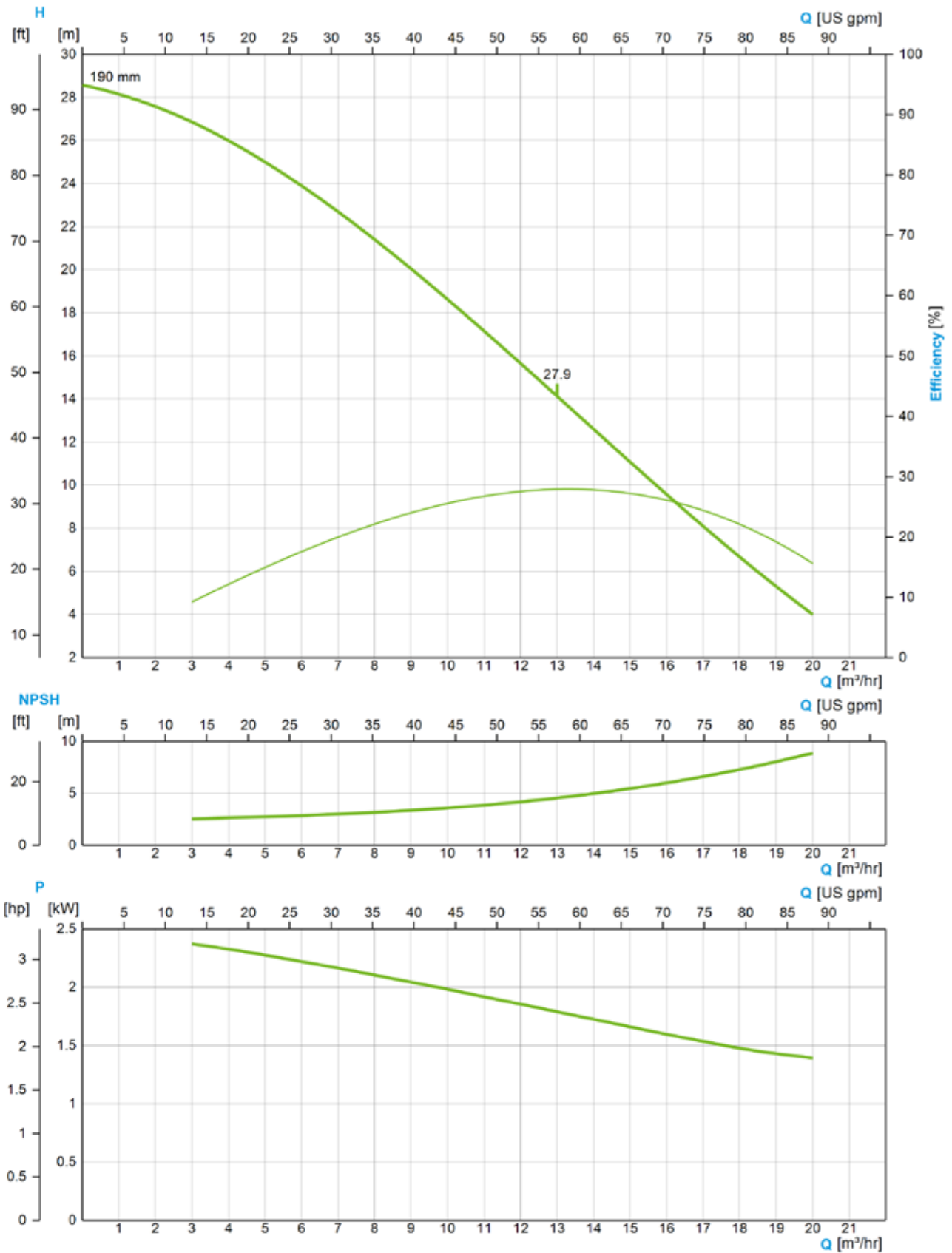

The flow charts are based on water, temperature 20 °C

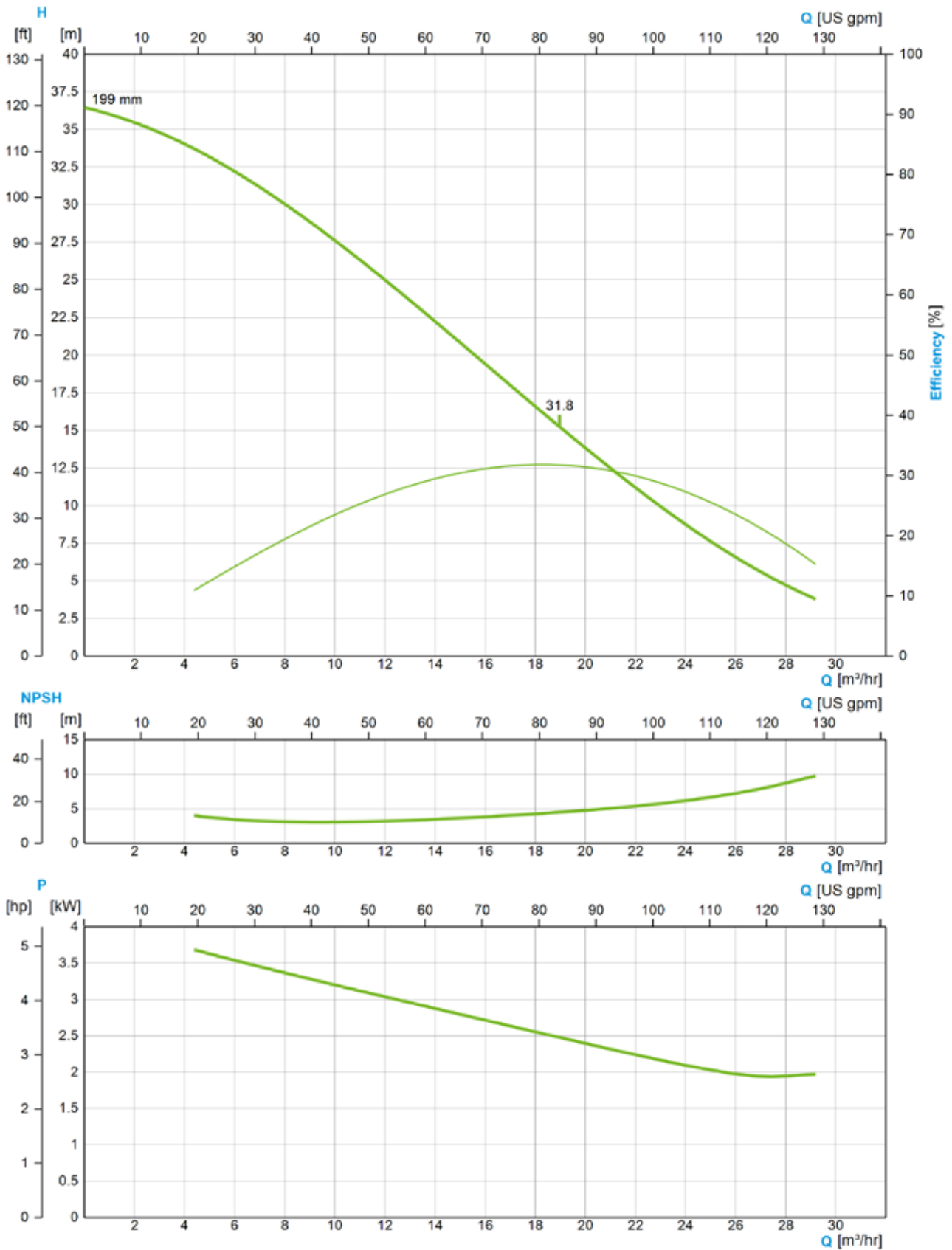

The flow charts are based on water, temperature 20 °C

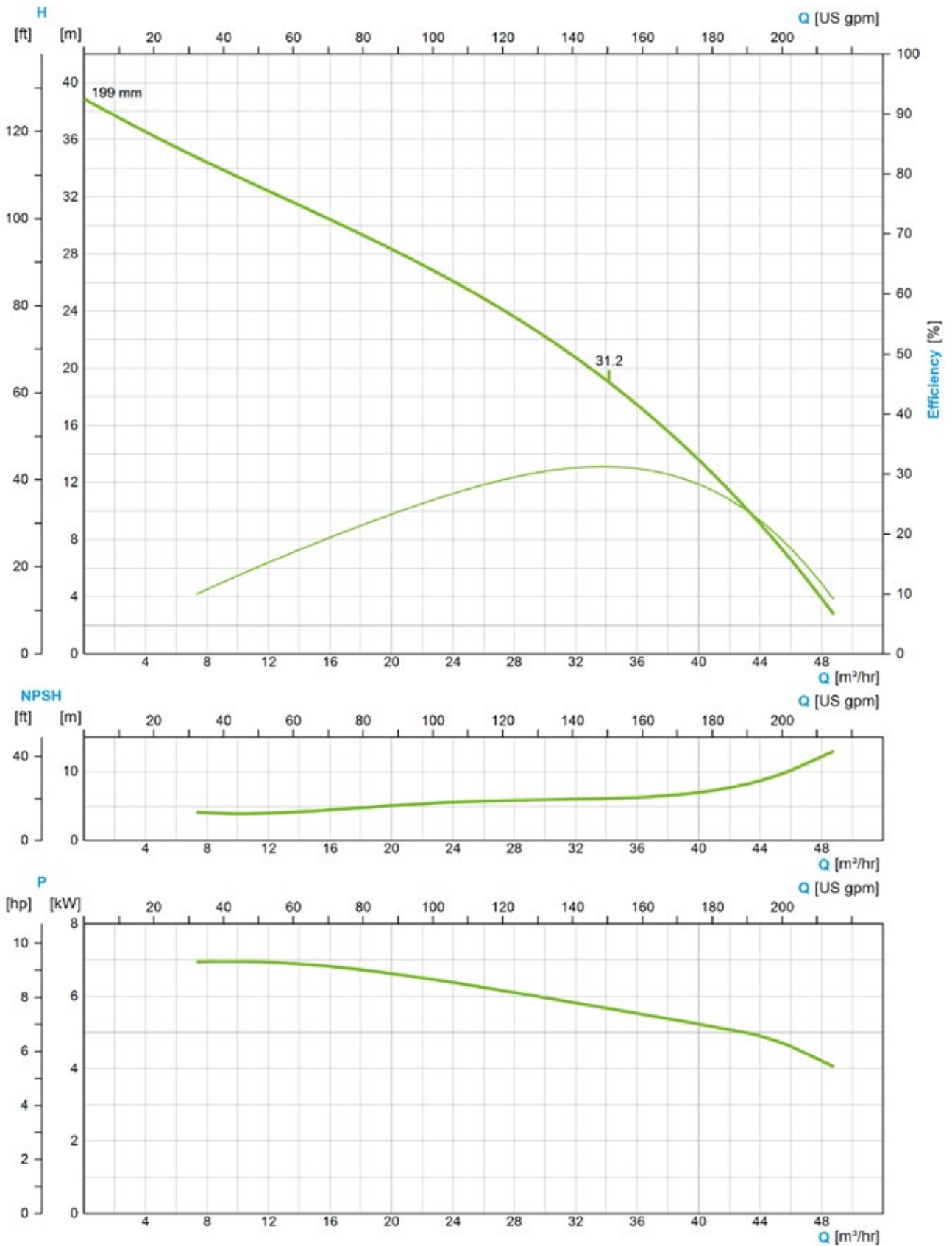

The flow charts are based on water, temperature 20 °C

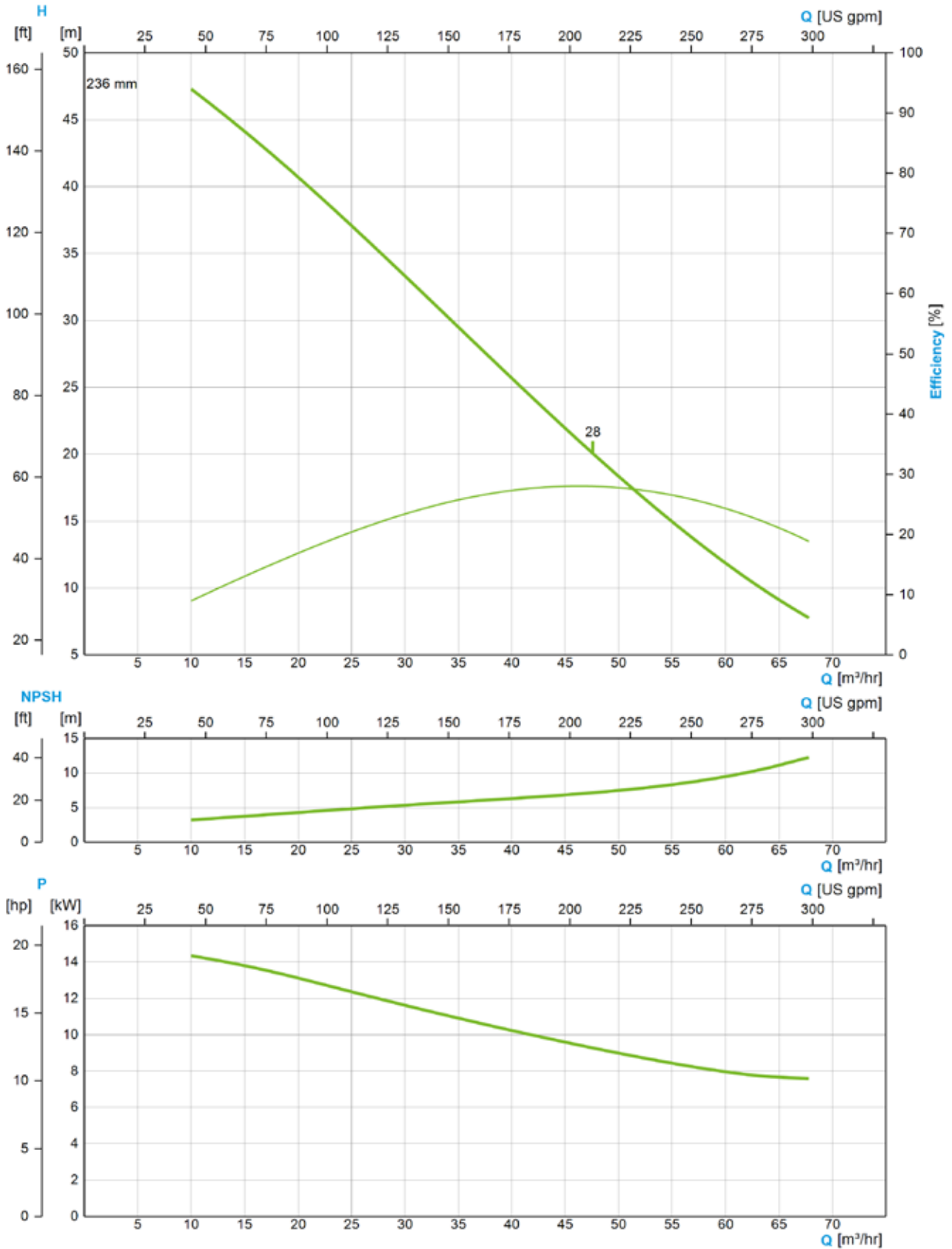

The flow charts are based on water, temperature 20 °C

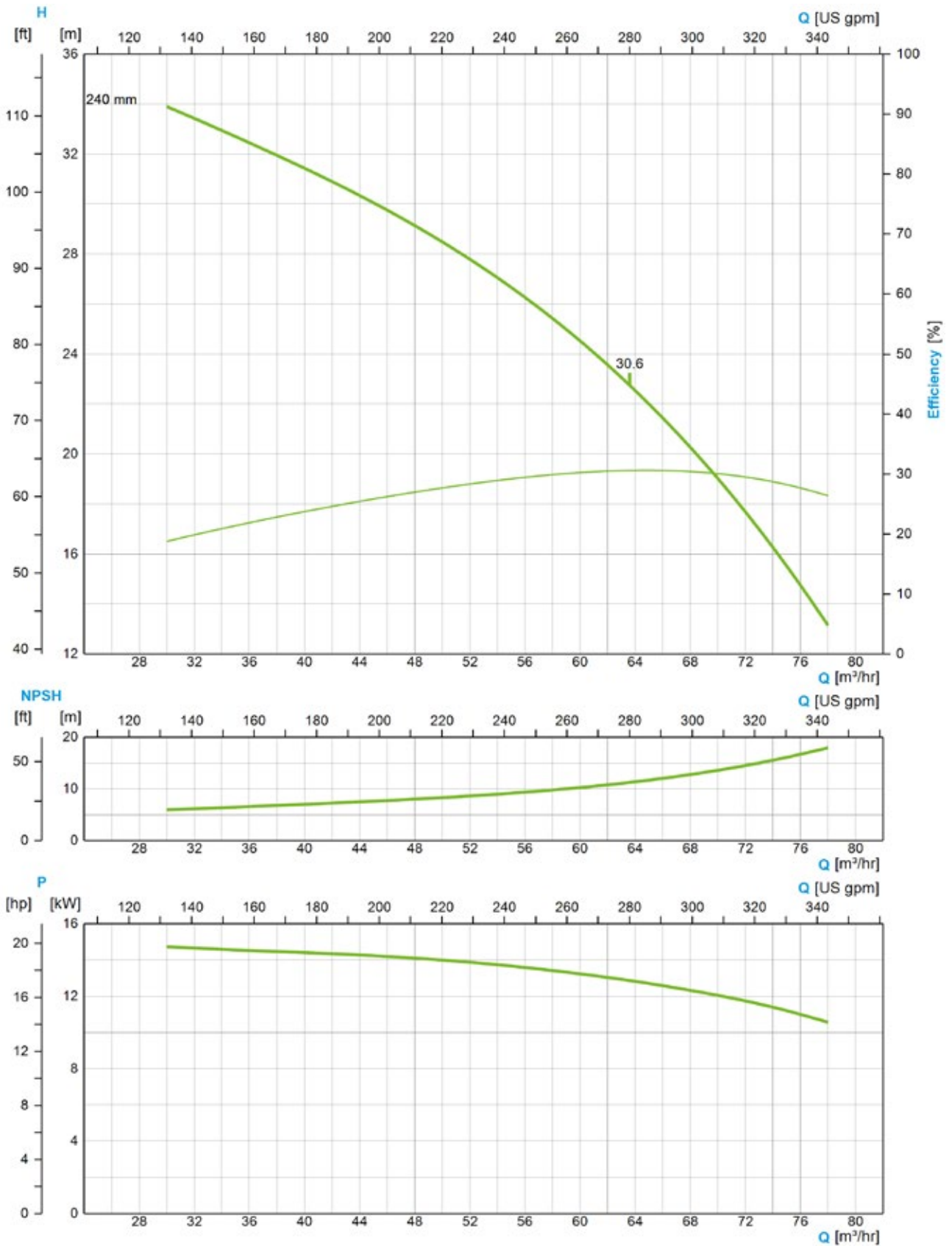

The flow charts are based on water, temperature 20 °C

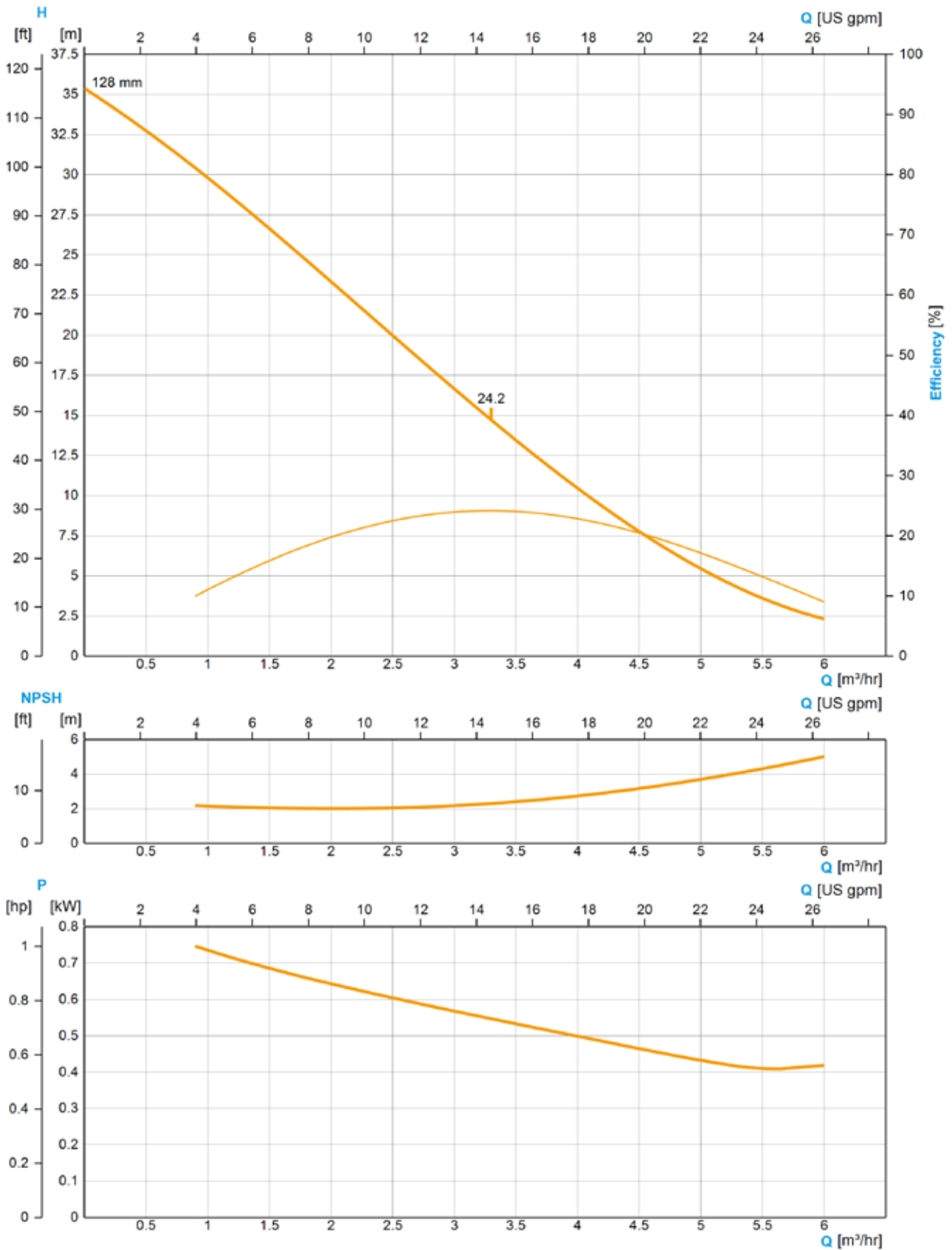

The flow charts are based on water, temperature 20 °C

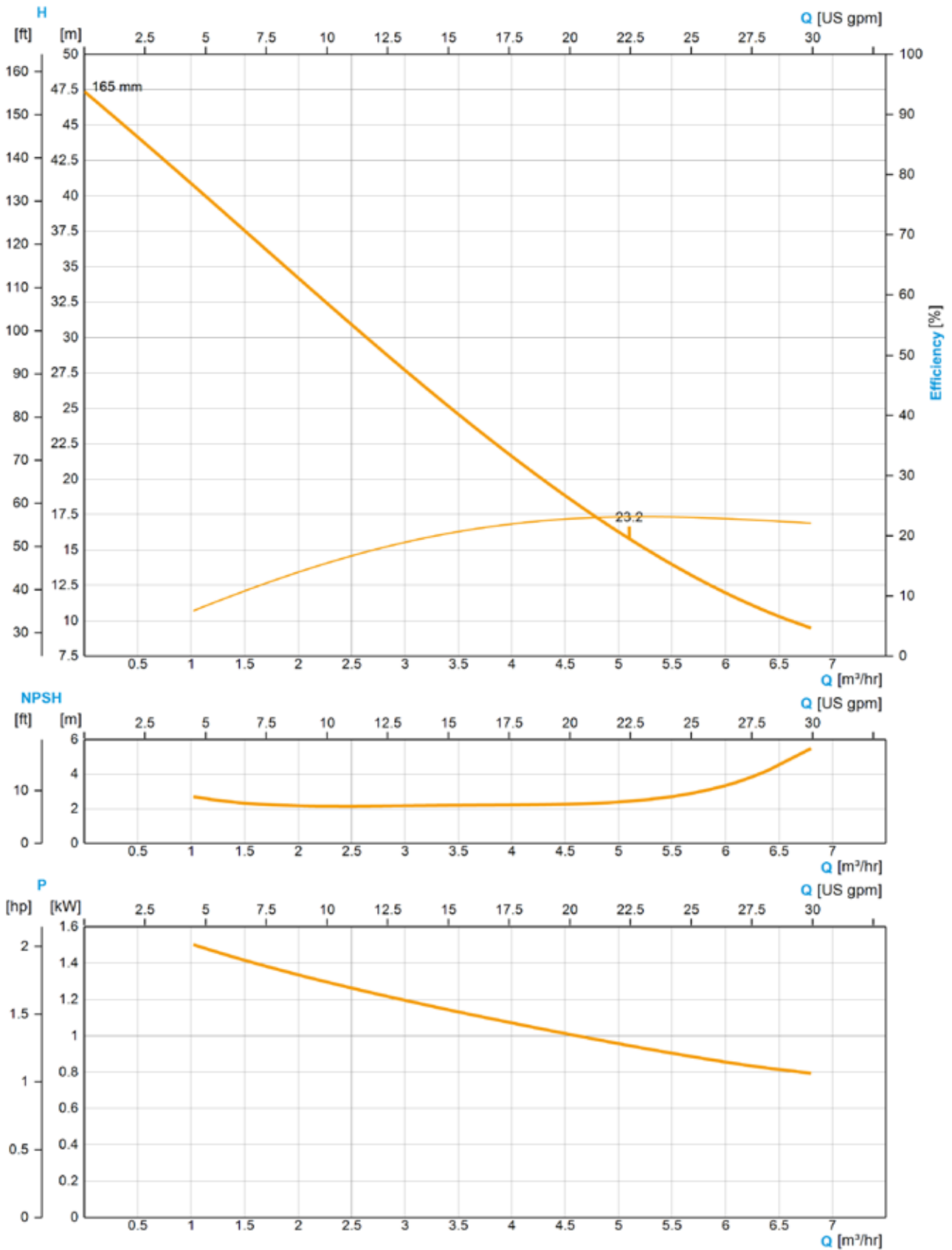

The flow charts are based on water, temperature 20 °C

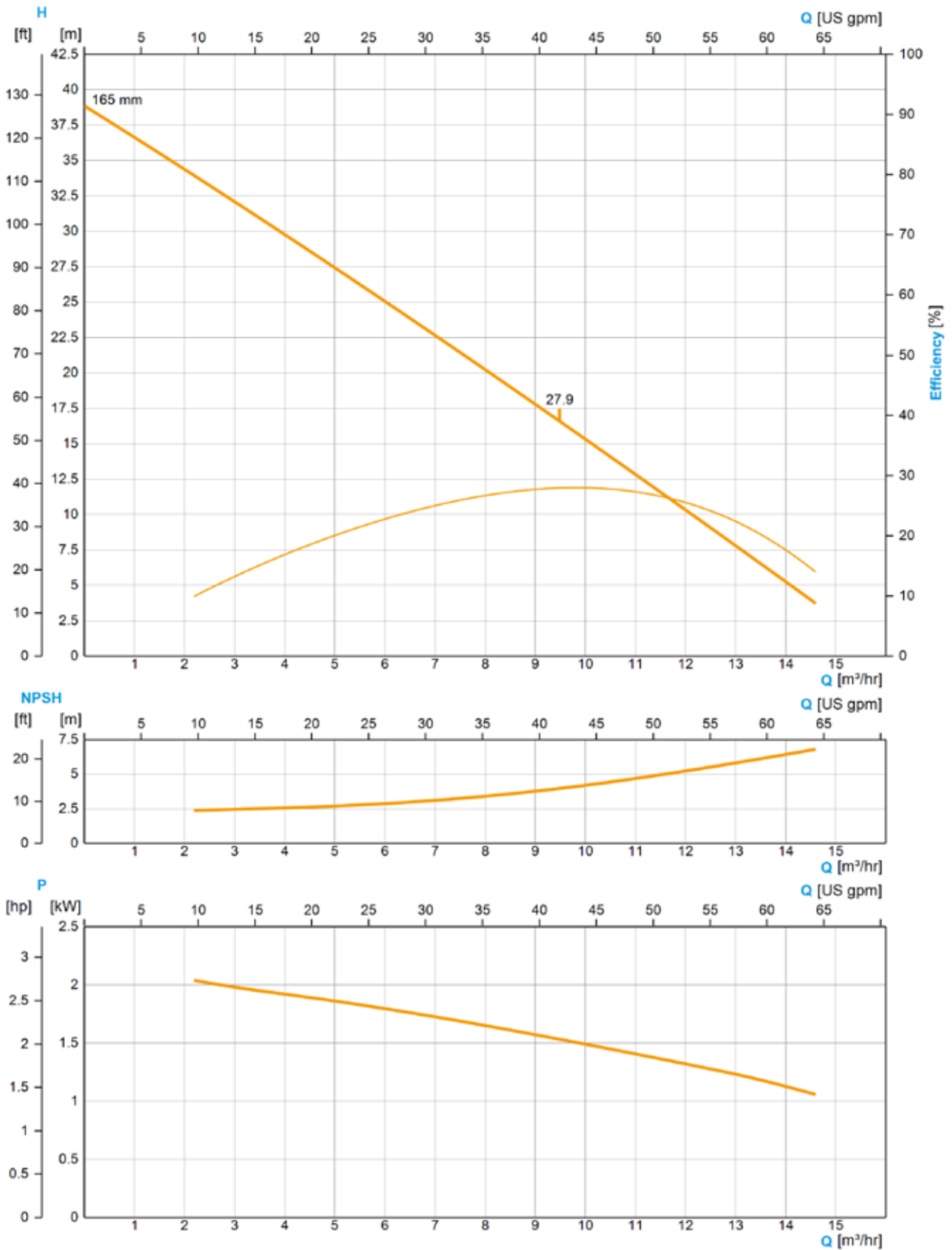

The flow charts are based on water, temperature 20 °C

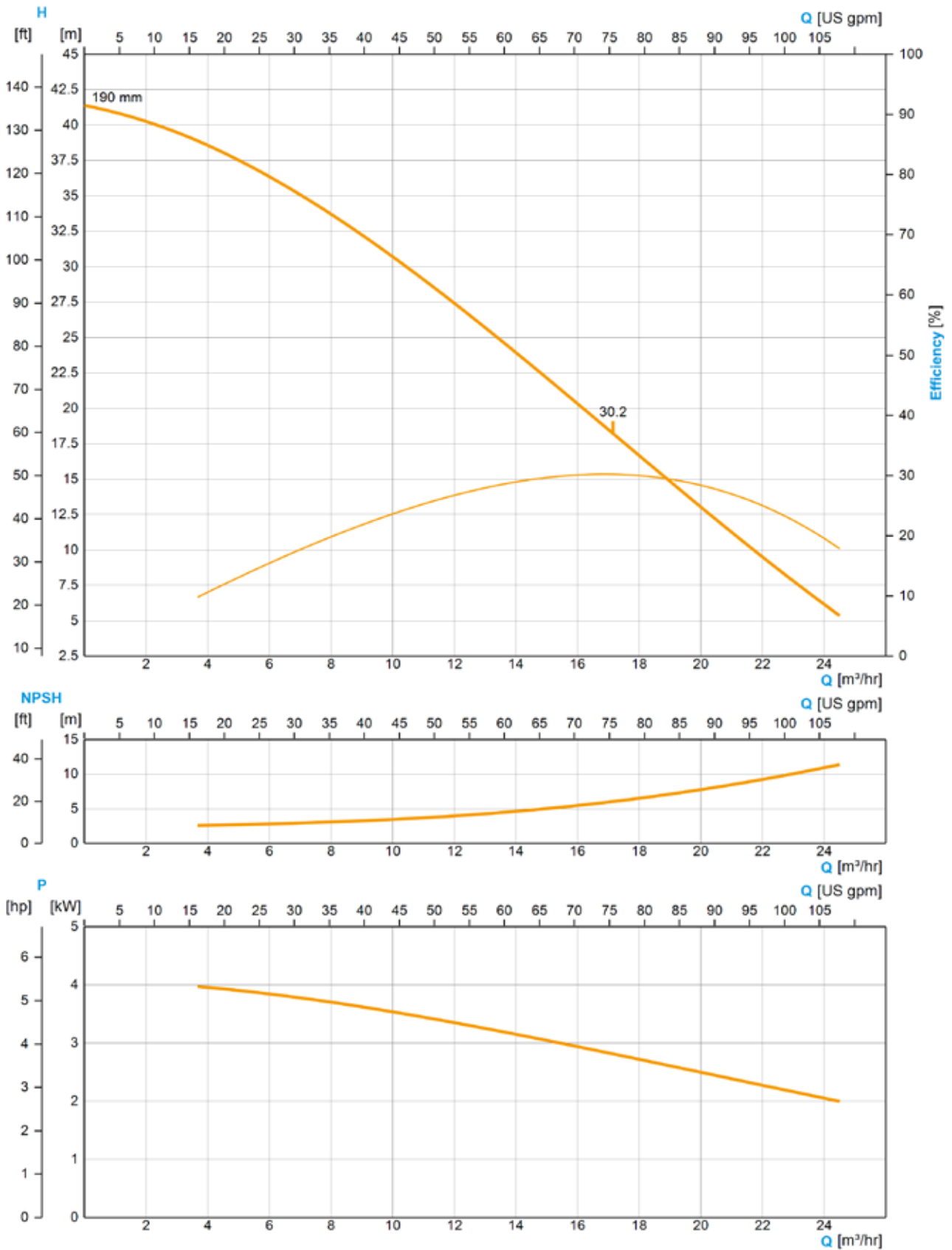

The flow charts are based on water, temperature 20 °C

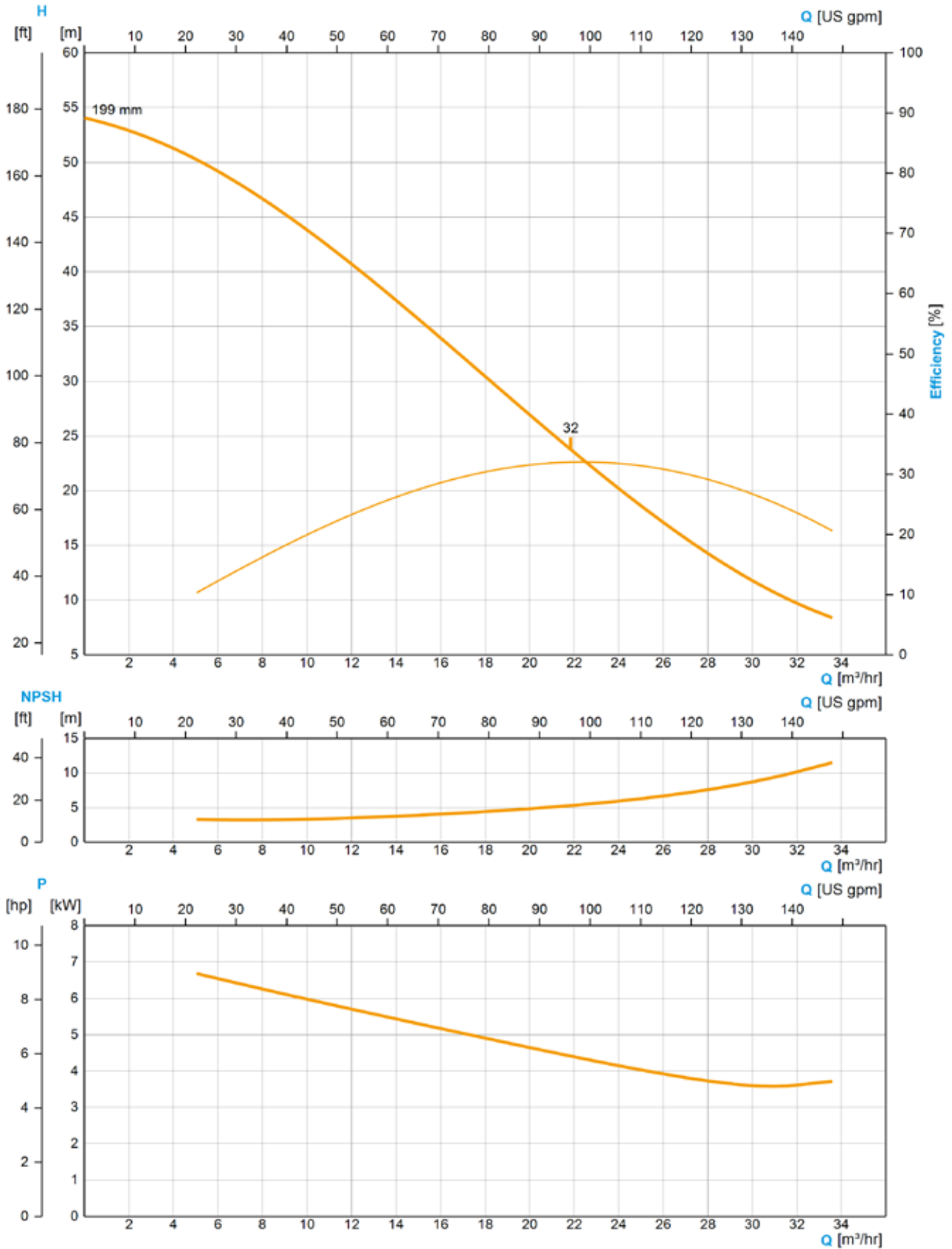

The flow charts are based on water, temperature 20 °C

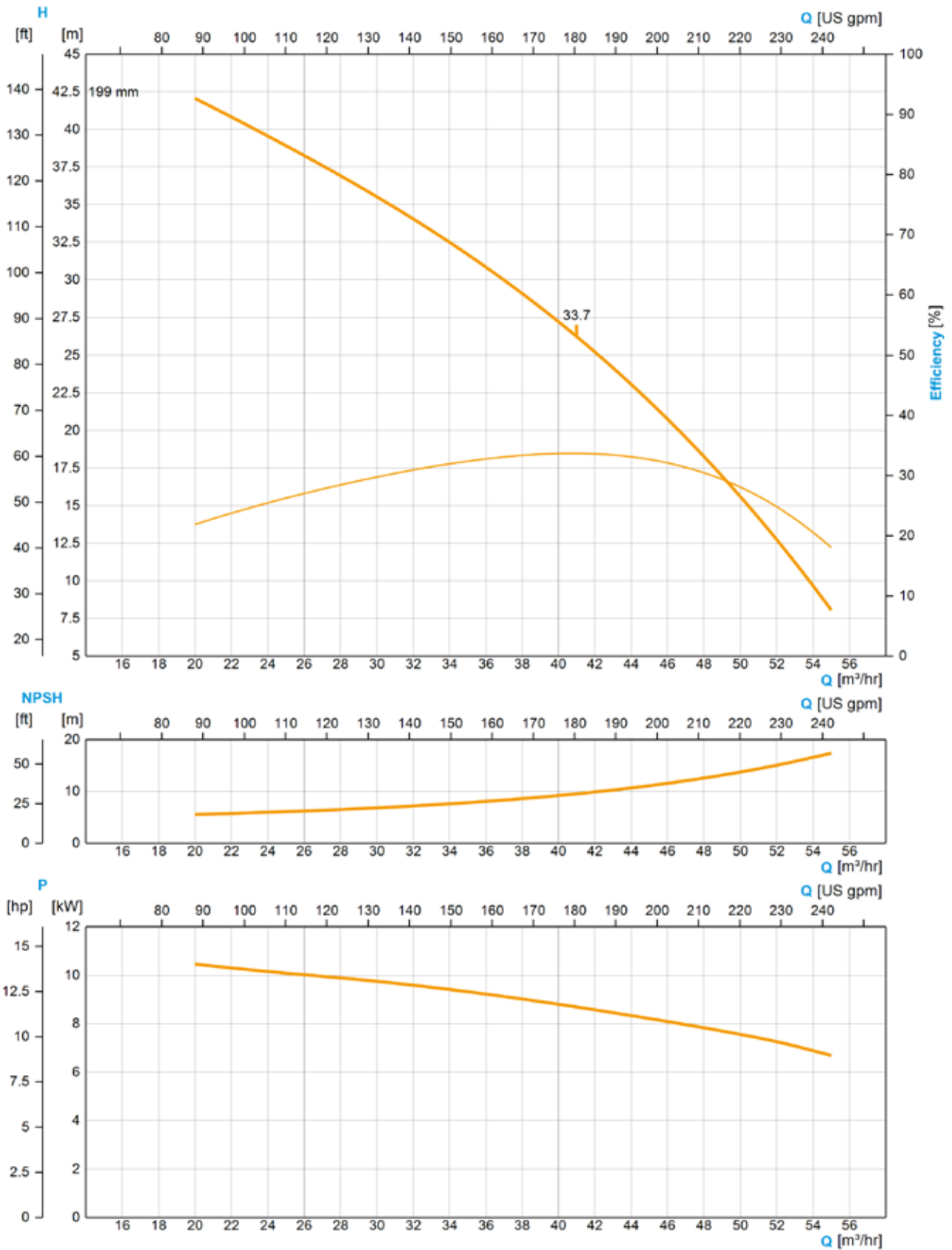

The flow charts are based on water, temperature 20 °C

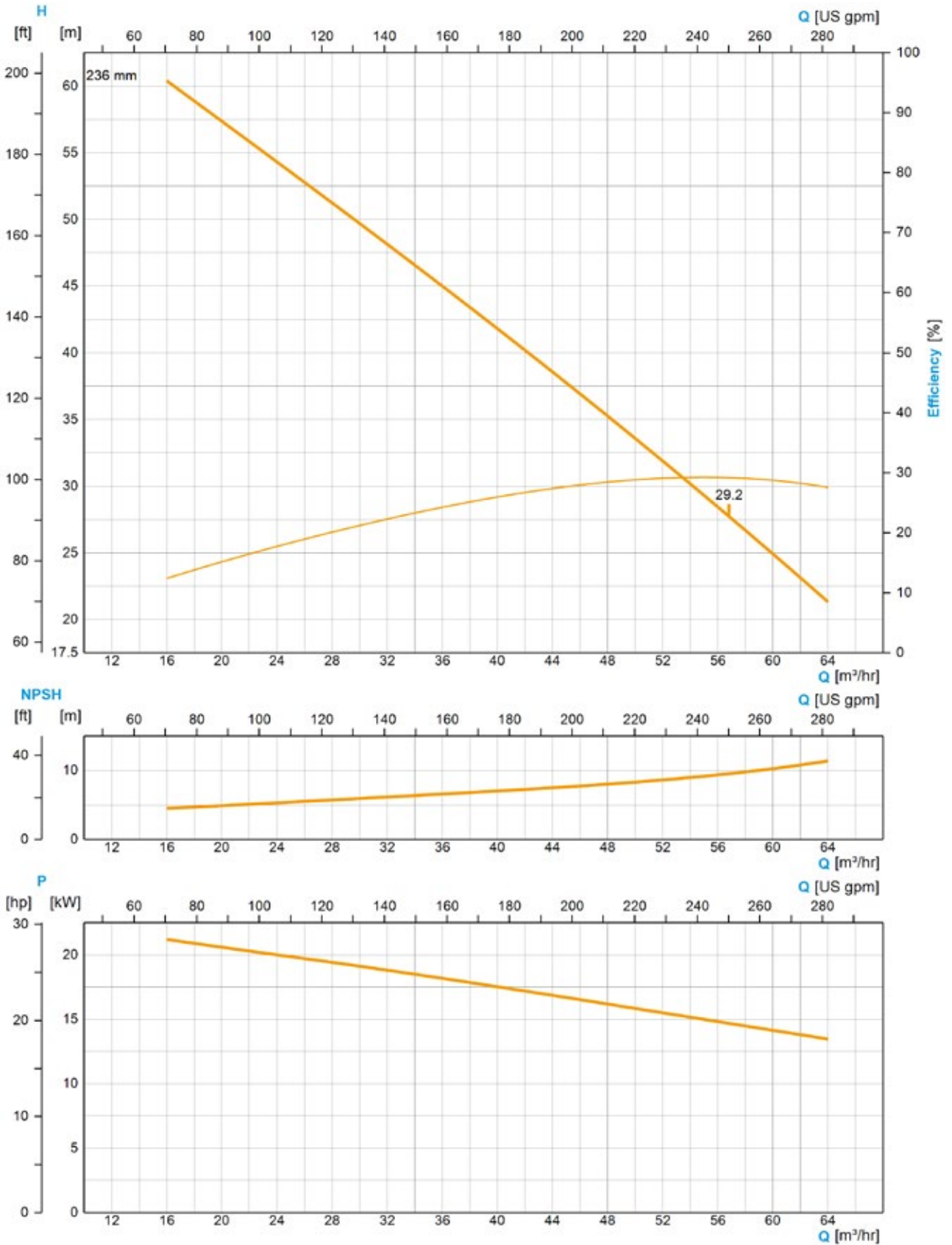

The flow charts are based on water, temperature 20 °C

INQUIRY SHEET · CENTRIFUGAL PUMPS 1/2



GEA Hygienic Pumps

Contact Data

Company: _____

Contact Person: _____ E-mail: _____

Phone: _____ Country: _____

Preferred Range

VARIPUMP SMARTPUMP No requirement

Liquid Data

*Liquid: _____ Solids: No Yes:

*Liquid temperature [°C/°F]: _____ Kind of solids: _____

*Density [kg/dm³]: _____ Size of solids [mm]: _____

*Viscosity [mPas]: _____ Abrasive: No Yes

Concentration [%]: _____

Operating Conditions

*Duty point 1 *Flow [m³/h/gpm]: _____ *Head [m lc]: _____

Duty point 2 Flow [m³/h/gpm]: _____ Head [m lc]: _____

End-suction pump: Self-priming pump:

Inlet pressure (NPSHa) [m]: _____ Suction head [m]: _____

Vacuum at inlet: No Yes: Gas content: No < 5 % > 5 %

Vacuum, abs. [mbar]: _____

System pressure [bar]: _____

Cleaning / Sterilization

CIP: No Yes: SIP: No Yes:

CIP Temperature [°C/°F]: _____ SIP Temperature [°C/°F]: _____

CIP Flow [m³/h/gpm]: _____ SIP Duration [min]: _____

CIP Head [m Fls]: _____

Pump execution

***Connection Type** **Connection Size** DN_i/DN_o: _____

Tri Clamp (DIN 32676) ANSI Flange DIN 11851 Other: _____

DIN 11853-2/11864-2 Other: _____ **Drainable:** No Yes

Execution and Design

Pump in Bloc version with motor Combi foot Motor foot

Pump in long coupled version with base plate and standard motor On Trolley Horizontal

With stainless steel motor shroud Cast iron foot Vertical

3-A stainless steel adjustable feet Stainless steel foot Vertical with stainless steel stand

INQUIRY SHEET · CENTRIFUGAL PUMPS 2/2



GEA Hygienic Pumps

Surface Roughness

- Not specified
- $R_a \leq 3.2 \mu\text{m}$
- $R_a \leq 0.8 \mu\text{m}$
- $R_a \leq 0.4 \mu\text{m}$

Ferrite Content

- Not specified
- Fe < 1%

Shaft Seal

- Single mechanical seal
- Flushed mechanical seal

Material Shaft Seal

- Carbon/Stainless Steel
- SiC/SiC
- Carbon/SiC
- other: _____

Elastomer

- EPDM
- FKM (Viton)
- other: _____

Motor Data

Power supply:

- 3~ 400V/50 Hz
- 3~ 200V/50 Hz
- other: _____
- 3~ 460V/60 Hz
- 3~ 200V/60 Hz
- 3~ 380V/60 Hz

Motor speed [1/min]: _____

PTC-Thermistors: No Yes

2 wire-Thermistors: No Yes

Variable speed drive No Yes:

- External frequency converter (not on motor)
- Integrated frequency converter (on motor)

Explosion protection No Yes

ATEX No Yes:

Ex-Zone: _____

Temperature class: _____

Ambient temperature [°C/°F]: _____

EXP Motor No Yes:

Temperature class: _____

Ambient Temperature [°C/°F]: _____

Class: _____

Division: _____

















Group: _____

Certificates/Documentation

- 3-A Sanitary Standard certification
- Inspection certificate 3.1 acc. to DIN EN 10204
- Test report 2.2 acc. to DIN EN 10204
- EHEDG certification
- Further certificates and documentation: _____
- FDA declaration of conformity
- Surface roughness test report
- Delta ferrite test report

Further Information

* Fields marked with an asterisk are mandatory for a pump selection

2.1		Works certificate according to DIN EN 10204: Declaration of the compliance with the order. This certificate is issued by the manufacturer.
2.2		Test report according to DIN EN 10204: Declaration of the compliance with the order under specification of the results of non-specific tests. This certificate is issued by the manufacturer.
3.1		Inspection certificate 3.1 according to DIN EN 10204: Declaration of the compliance with the order under specification of the results of specific tests. This certificate is issued by an authority which is independent of manufacturing and is validated by the manufacturers authorized inspection representative.
3-A		3-A Sanitary Standards, Inc. (3-A SSI) is an independent, non-profit corporation dedicated to advancing hygienic equipment design for the food, beverage, and pharmaceutical industries.
AS-i		Actuator Sensor interface. BUS system for the lowest field level.
ASME-BPE		Standard of the ASME's – bioprocessing equipment association
ATEX		Atmosphères Explosibles. ATEX comprises the directives of the European Union in the area of explosion protection. For one thing, this is the ATEX equipment directive 94/9/EC, for another, the ATEX workplace directive 1999/92/EC.
cCSAus		Test of a product by CSA according to applicable safety standards in Canada and the USA.
CE		Conformité Européenne. By affixing the CE mark, the manufacturer confirms that the product complies with the European directives applicable to the specific product.
CSA		Canadian Standards Association. A non-governmental Canadian organization which issues standards as well as checking and certifying the safety of products. It is now globally active.
cULus		Test of a product by UL according to applicable safety standards in Canada and the USA.
DIN EN ISO 9001:2015		This norm is the basis for a multitude of varied organizations in different industries worldwide for quality assurance and quality management. It is the most widespread standards of ISO (International Organisation for Standardization).
EAC		Euroasion conformity. The symbol is used similar to the European CE mark. The manufacturer or supplier confirms that the machine has passed all necessary compliance procedures in one of the Member States of the customs union.
EG 1935/2004		Materials in contact with the product used in pumps from GEA Hilge are in accordance with EC regulation 1935/2004. This defines a general framework for materials and objects intended to come into contact with foodstuffs.
EHEDG		European Hygienic Engineering & Design Group. European supervisory authority for foodstuffs and pharmaceuticals. This authority issues approvals and certificates for products and materials that are used in the foodstuffs and pharmaceuticals industries.
FDA		Food and Drug Administration. US supervisory authority for foodstuffs and pharmaceuticals. This authority issues approvals and certificates for products and materials that are used in the foodstuffs and pharmaceuticals industries.
QHD		The QHD (Qualified Hygienic Design) is a two-phase testing system for the hygienic design and cleanability of components, machinery and plants for aseptic or sterile applications. The system ensures that all surfaces can be cleaned in place (CIP). The QHD symbol is used by manufacturers to indicate compliance with the QHD criteria.
UL		Underwriters Laboratories. An organization founded in the USA for checking and certifying products and their safety.
USP Class VI		The United States Pharmacopeial Convention (USP) is a scientific nonprofit organization that sets standards to help protecting public health. Class VI administer tests and impacts of material and their substances on animal and human tissues.

Abbreviation	Explanation
°C	Degrees Celsius, unit of measurement for temperature
°F	Degrees Fahrenheit, unit of measurement for temperature
3D	Three-dimensional
A	Ampere, unit of measurement of current intensity or Output, term used in automation
AC	Alternating Current
ADI free	All elastomer compounds are free of animal-derived ingredients
AISI	American Iron and Steel Institute, association of the American steel industry
ANSI	American National Standards Institute, American body for standardizing industrial processes
approx.	approximately
AS-i	Actuator Sensor interface, standard for fieldbus communication
ASME	American Society of Mechanical Engineers, professional association of mechanical engineers in the USA
ASME-BPE	Standard of the ASME's – bioprocessing equipment association
ATEX	Atmosphères Explosibles, synonymous with the directives of the European Union for potentially explosive areas
bar	Unit of measurement for pressure. All pressure values [bar/psi] refer to positive pressure [bar _g /psi _g], unless specifically stated otherwise.
bar _g	Unit of measurement for pressure relative to atmospheric pressure
CAN	Controller Area Network; asynchronous serial bus system
CE	Conformité Européenne, administrative symbol for the free movement of industrial products
CIP	Cleaning In Place, designates a process for cleaning technical process systems.
CRN	Canadian Registration Number, is issued by a Canadian Jurisdiction and covers pressure vessels, fittings, or pressure piping. It is a necessary authorization allowing these components to be in operation in Canada.
CSA	Canadian Standards Association, a non-governmental Canadian Standardization organization
Cv	The Cv value corresponds to the water flow rate through a valve (in US gal / min) at a pressure differential of 1 PSI and a water temperature of 5 °C to 30 °C. kv = 14,28 Cv (USA).
Cvs	The Cv values of a valve at nominal stroke (100 % opening) is designated the Cvs value.
dB	Decibel, one tenth of a bel, named after Alexander Graham Bell and used for identifying levels and dimensions
DC	Direct Current
DIN	Deutsches Institut für Normung e. V. Standardization organization in the Federal Republic of Germany, DIN = synonym for standards issued by the organization

Abbreviation	Explanation
DIP	Dual Inline Package, design of a switch
DN	Diameter Nominal, DIN nominal width
Device Net	Network system used in the automation industry to interconnect control devices for data exchange
E	Input, term used in automation
EAC	Certification of technical conformity from the customs union of Russia/Balarus/Kazakhstan
Pressure Equipment Directive 97/23/EC	Directive of the European Parliament and the Council Directive for layout and conformity evaluation for pressure equipment and assemblies with a maximum pressure (PS) of more than 0.5 bars.
EG No. 1935/2004	Regulation of the European Parliament which lays down common rules for materials which come, or may come, into contact with food, either directly or indirectly.
EHEDG	European Hygienic Engineering and Design Group. Consortium of equipment manufacturers, food industries, research institutes as well as public health authorities
EN	European standard, rules of the European Committee for Standardization
EPDM	Ethylene propylene diene rubber, acronym acc. to DIN/ISO 1629
Ex	Synonym for ATEX
FDA	Food and Drug Administration, official foodstuffs monitoring in the United States
FEM calculation	Finite Element Method; calculation process for simulating solids
FKM	Fluorinated rubber, acronym acc. to DIN/ISO 1629
GOST	Gosudarstvennyy Standart, Certification of conformity for components according to standards and regulations of the Russian Federation
H	Henry, unit of measurement for inductance
HNBR	Hydrated acrylonitrile butadiene rubber, acronym acc. to DIN/ISO 1629
Hz	Hertz, unit of frequency named after Heinrich Hertz
I	Formula symbol for electrical current
IEC	International Electrotechnical Commission, international standardization organization for electrical and electronic engineering
IP	Ingress Protection/International Protection, index of protection class acc. to IEC 60529
IPS	Iron Pipe Size, American pipe dimension
ISA	International Society of Automation, international US organization of the automation industry
ISO	International Organization for Standardization, international organization that produced international standards, ISO = synonym for standards from the organization
kg	Kilogram, unit of measurement for weight
Kv	The Kv value corresponds to the water flow rate through a valve (in m ³ /h) at a pressure differential of 0.98 bar and a water temperature of 5 °C to 30 °C.

Abbreviation	Explanation
Kvs	The Kv values of a valve at nominal stroke (100 % opening) is designated the Kvs value
L	Conductive
LED	Light-Emitting Diode
mm	Millimeter, unit of measurement for length
M	Metric, system of units based on the meter or Mega, one million times a unit
m ³ /h	Cubic meters per hour, unit of measurement for volumetric flow
max.	Maximum
NAMUR	Standardization working association for measuring and control technology in the chemical industry, synonym for the interface type of the organization, especially for potentially explosive atmospheres
NC	Normally Closed; valve or solenoid valve control which is closed in idle status
NO	Normally Open; valve or solenoid valve control which is open in idle status
NOT-element	Logic element, NOT gate
NPN	Signal transmission against reference potential, current-consuming
NPT	National Pipe Thread, US thread standard for self-sealing pipe fittings
OD	Outside Diameter, pipe dimension
ODVA	Open DeviceNet Vendor Association, global association for network standards
PA 12/L	Polyamide
Pg	Armored thread
PN	Nominal pressure for pipeline systems according to EN 1333, rated pressure in bar at room temperature (20 °C)
PNP	Signal transmission against reference potential, current-supplying
PPO	Polyphenylene oxide, thermoplastic material
PS	Maximum permitted operating pressure at which the components can operate safely at maximum allowable temperature (TS)
psi	Unit of measurement for pressure, pound-force per square inch, 1 psi = 6894.75 Pa. All pressure values [bar/psi] refer to positive pressure [bar _g /psi _g], unless specifically stated otherwise.
psi _g	Unit of measurement for pressure relative to atmospheric pressure
PV	Solenoid valve
R _a in μm	Average roughness value, describes the roughness of a technical surface
International Protection-Code IP67, IP66, IP69K	Classifies and rates the degree of protection provided against intrusion dust, accidental contact, and water

Abbreviation	Explanation
SES	GEA Tuchenhagen control head for Ex areas, control top system of GEA Tuchenhagen
SET-UP	Self-learning installation, the SET-UP procedure carries out all necessary settings for generating messages during commissioning and maintenance.
SIP	Sterilization in Place, refers to a process for cleaning technical process systems
SMS	Svensk Mjök Standard, Scandinavian pipe dimension
SW	Indicates the size of a tool spanner, "Schlüsselweite"
TA-Luft VDI 2440	If a product is certified according to TA Luft it meets the requirements for proof of high grade performance according to TA Luft of 1.0×10^{-4} mbar x l / (s x m) at service conditions under the VDI guideline 2440. The product will hence be tested for tightness.
TS	Maximum permitted operating temperature
UL	Underwriters Laboratories, a certification organization established in the USA
USP Class VI	The United States Pharmacopeial Convention (USP) is a scientific nonprofit organization that sets standards to help protecting public health. Class VI administer tests and impacts of material and their substances on animal and human tissues.
UV	Ultraviolet, ultraviolet radiation is a wavelength of light
V	Volt, unit of measurement for voltage
VMQ	High-polymer vinyl methyl polysiloxane, silicone rubber, MVQ = synonym
W	Watt, unit of measurement for power
Y	Control air connection for the working cylinder, designation from pneumatic systems
μ	Micro, one millionth of a unit
Ω	Ohm, the unit of electrical resistance named after Georg Simon Ohm

We live our values.

Excellence • Passion • Integrity • Responsibility • GEA-versity

GEA is one of the largest technology suppliers for food processing and a wide range of other industries. The global group specializes in machinery, plants, as well as process technology and components. GEA provides sustainable solutions for sophisticated production processes in diverse end-user markets and offers a comprehensive service portfolio

The company is listed on the German MDAX (G1A, WKN 660 200), the STOXX® Europe 600 Index and selected MSCI Global Sustainability Indexes.

GEA Germany

GEA Hilge

Niederlassung der GEA Tuchenhagen GmbH

Hilgestraße 37–47

55294 Bodenheim, Germany

Tel +49 6135 7016-0

Fax +49 6135 1737

gea.com/germany