

4C and 4CN – for KSB's CPK and CPKN pump type series

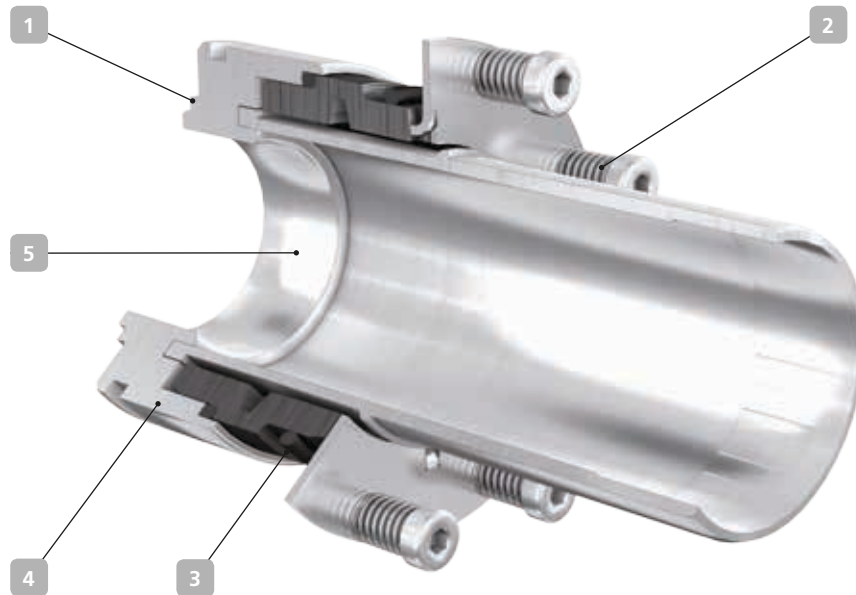

Applications:
chemical and petrochemical industries

1 Robust

Tailored to the conical installation space of the pump (A-type cover). Suitable for solids-laden fluids.

2 Dependable

Stationary design, multiple springs located outside the fluid handled. The large springs are insensitive to contamination and ensure an optimal service life.

3 Different material variants

Elastomers made of EPDM/FKM or, alternatively, perfluoroelastomer (FFKM). Springs made of 1.4310 or, alternatively, Hastelloy.

4 Versatile

Can optionally also be operated with unpressurised quench liquid.

5 Service-friendly

Easy to install, no adjustments required when installing.

Technical description

Design	Single mechanical seal
Type	Stationary, balanced
Springs	Multi-spring arrangement
Direction of rotation	Bi-directional
Additional information	Various wear part kits available, see ZN3302

Materials

Primary ring	SiC (Q1)
Mating ring	SiC (Q1)
Elastomers	EPDM (E) / FKM (V) / FFKM (K)
Springs	1.4571 (G) / 2.4610 (M)
Other Components	1.4462 (G1) / 2.4610 (M)

Other material combinations on request

Technical data

Operating pressure	Up to 25 bar, dynamic Up to 37.5 bar, static
Temperature	20 °C to 150 °C
Bearing bracket (seal size)	P02 (030), P03 (040), P04 (050), P05 (060), P06 (070), P08 (080)
Business type	Engineered