

4EDBM6S & Q – single mechanical seals to API 682, 4th edition

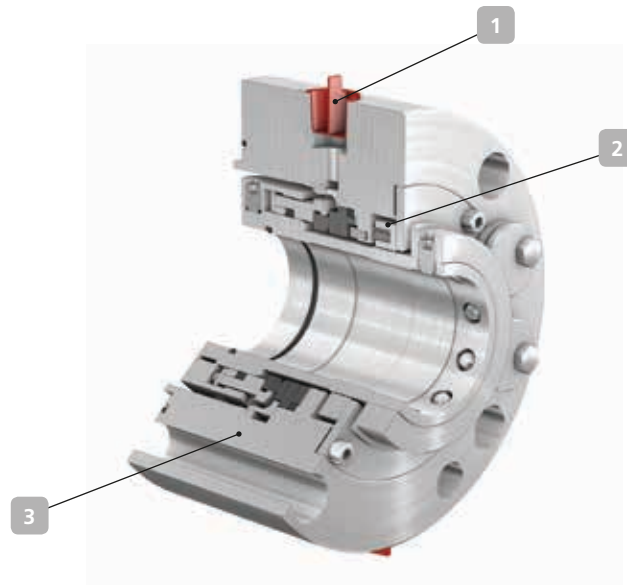

Applications:
API 682 applications in the chemical and petrochemical industries

Arrangement 1 Contacting, single, product-lubricated and balanced cartridge seal

1 Flexible

The single cartridge seal can be connected to all common API Plans, such as 01, 02, 11, 31, 32 + 51, 61 (62) and 23 + 51, 61 (62). The seals are available for all of KSB's API pumps.

2 Dependable

The throttling bush enables connection to a gas, steam or liquid quench, depending on the seal variant. This prevents outboard incrustations at the seal.

3 Efficient

The API Plan combination 02 + 23 with high-efficiency pumping ring is perfectly matched to applications with hot fluids.

Variants

Variants 4EDBM6S

Single mechanical seal with floating throttling bush for optional connection to a gas or steam quench.

Variant 4EDBM6Q

Single mechanical seal with segmented throttling bush for use with a liquid quench.

Technical description

Category	II or III
Type	A
Arrangement	1
Design	Cartridge
Additional information	Various wear part kits available on request

Materials

Primary ring	"A" carbon (A) / SiC-Si (Q2)
Mating ring	SiC-Si (Q2)
Elastomers	FKM (V) / FFKM (K)
Springs	2.4610 (M)
Other Components	1.4571 (G)
Other material combinations on request	

Technical data

Shaft diameter	50 to 120 mm
Pressure	Up to 40 bar
Temperature	-10 to 200 °C
Higher application limits on request	