

Submersible Pump in Discharge Tube

AmaCan D

50 Hz

Installation/Operating Manual



Mat. No.: 05157021

CE

KSB 

Legal information/Copyright

Installation/Operating Manual AmaCan D

Original operating manual

All rights reserved. The contents provided herein must neither be distributed, copied, reproduced, edited or processed for any other purpose, nor otherwise transmitted, published or made available to a third party without the manufacturer's express written consent.

Subject to technical modification without prior notice.

© KSB SE & Co. KGaA, Frankenthal 2023-11-29

Contents

	Glossary	7
1	General	8
	1.1 Principles.....	8
	1.2 Installation of partly completed machinery.....	8
	1.3 Target group.....	8
	1.4 Other applicable documents.....	8
	1.5 Symbols.....	8
	1.6 Key to safety symbols/markings.....	9
2	Safety	10
	2.1 General.....	10
	2.2 Intended use.....	10
	2.3 Personnel qualification and training.....	10
	2.4 Consequences and risks caused by non-compliance with this manual.....	11
	2.5 Safety awareness.....	11
	2.6 Safety information for the operator/user.....	11
	2.7 Safety information for maintenance, inspection and installation.....	11
	2.8 Unauthorised modes of operation.....	12
	2.9 Explosion protection.....	12
	2.9.1 Repair.....	12
3	Transport/Storage/Disposal	13
	3.1 Checking the condition upon delivery.....	13
	3.2 Transport.....	13
	3.2.1 Transporting the delivered pump set to the place of installation.....	13
	3.2.2 Placing the pump set in a vertical or horizontal position.....	13
	3.2.3 Transporting the pump set.....	15
	3.3 Storage/preservation.....	16
	3.4 Return to supplier.....	18
	3.5 Disposal.....	18
4	Description of the Pump (Set)	19
	4.1 General description.....	19
	4.2 Designation.....	19
	4.3 Name plate.....	20
	4.4 Design details.....	20
	4.5 Installation types.....	21
	4.6 Configuration and function.....	22
	4.7 Scope of supply.....	23
	4.8 Dimensions and weights.....	23
5	Installation at Site	24
	5.1 Safety regulations.....	24
	5.2 Checks to be carried out prior to installation.....	24
	5.2.1 Checking the structural requirements.....	24
	5.2.2 Checking the operating data.....	25
	5.2.3 Checking the lubricant of the mechanical seal.....	25
	5.2.4 Checking the direction of rotation.....	26
	5.3 Lowering the pump set into the discharge tube.....	27
	5.3.1 Information for correct installation.....	28
	5.3.2 Installation without support rope.....	29
	5.3.3 Installation with a support rope.....	30
	5.3.4 Installation with a support rope and support spacer.....	34
	5.4 Electrical system.....	39
	5.4.1 Information for planning the control system.....	39
	5.4.1.1 Starting method.....	39

5.4.1.2	Setting the overload protection device	39
5.4.1.3	Level control	39
5.4.1.4	Operation on a frequency inverter	40
5.4.1.5	Sensors	41
5.4.2	Electrical connection	45
6	Commissioning/Start-up/Shutdown	48
6.1	Commissioning/Start-up	48
6.1.1	Prerequisites for commissioning/start-up	48
6.1.2	Start-up	49
6.2	Operating limits	49
6.2.1	Operation on the power supply mains	50
6.2.2	Frequency of starts	50
6.2.3	Operation on a frequency inverter	50
6.2.4	Fluid handled	51
6.2.4.1	Fluid temperature	51
6.2.4.2	Density of the fluid handled	51
6.2.4.3	Minimum level of fluid handled	51
6.2.4.4	Abrasive fluids	52
6.3	Shutdown/storage/preservation	52
6.3.1	Shutdown	52
6.3.2	Measures to be taken for shutdown	52
6.4	Returning to service	53
7	Servicing/Maintenance	54
7.1	Safety regulations	54
7.2	Maintenance/inspection	56
7.2.1	Inspection work	57
7.2.1.1	Measuring the insulation resistance	57
7.2.1.2	Checking the sensors	57
7.3	Removing the pump set	59
7.3.1	Removing the pump set	59
7.3.2	Drainage/cleaning	61
7.3.3	Checking the cable bundle	61
7.3.4	Checking the lifting accessories	61
7.3.5	Checking the earth conductor	61
7.3.6	Checking the mechanical seal leakage	62
7.3.7	Visually inspecting for corrosion	63
7.4	Lubrication and lubricant change	63
7.4.1	Lubricating the mechanical seal	63
7.4.1.1	Intervals	63
7.4.1.2	Lubricant quality	63
7.4.1.3	Lubricant quantity	64
7.4.1.4	Changing the lubricant	64
7.4.2	Lubrication and lubricant change of rolling element bearings	66
7.4.2.1	Intervals	66
7.4.2.2	Grease quality	67
7.4.2.3	Grease quantity	67
7.5	Dismantling the pump set	68
7.5.1	General information/Safety regulations	68
7.5.2	Preparing the pump set	69
7.5.3	Removing the bellmouth and casing wear ring	70
7.5.4	Removing the impeller	70
7.5.4.1	Overview of impeller design	70
7.5.4.2	Removing the impeller with tapered fit	71
7.5.4.3	Removing the impeller with cylindrical fit	72
7.5.5	Removing the mechanical seal	72
7.5.5.1	Impeller-end mechanical seal	72
7.5.5.2	Drive-end mechanical seal	73
7.5.6	Dismantling the motor section	74
7.5.6.1	Removing the motor housing cover	74

7.5.6.2	Removing the cable gland and connection cable	76
7.6	Reassembling the pump set	76
7.6.1	General information/Safety regulations.....	76
7.6.2	Installing the replacement cable gland	78
7.6.3	Fitting the motor housing cover	79
7.6.4	Installing the mechanical seal	81
7.6.4.1	Installing the drive-end mechanical seal	81
7.6.4.2	Impeller-end mechanical seal	83
7.6.5	Fitting the impeller	83
7.6.5.1	Overview of impeller design	83
7.6.5.2	Fitting the impeller with tapered fit.....	84
7.6.5.3	Fitting the impeller with cylindrical fit.....	85
7.6.6	Fitting the casing wear ring	85
7.6.6.1	Adjusting the clearance	86
7.6.7	Fitting the bellmouth.....	87
7.6.8	Leak testing	88
7.6.8.1	Testing the lubricant reservoir for leakage	88
7.6.8.2	Checking the motor for leakage	88
7.7	Checking the electrical connection and motor.....	89
7.8	Replacing the sacrificial anode	90
7.8.1	Interval.....	90
7.8.2	Replacing the sacrificial anodes at the bail.....	90
7.8.3	Replacing the sacrificial anodes at the bellmouth.....	91
7.8.4	Replacing sacrificial anodes at the pump bowl.....	92
7.9	Tightening torques	92
7.10	Spare parts stock.....	93
7.10.1	Ordering spare parts.....	93
7.10.2	Recommended spare parts stock for 2 years' operation to DIN 24296.....	93
8	Trouble-shooting	95
9	Related Documents.....	97
9.1	General assembly drawing with list of components	97
9.2	Detail drawings.....	99
9.2.1	Cable gland and fastening	99
9.2.2	Bearing temperature sensors	101
9.2.3	Bearings	102
9.2.4	Sensors, bearing housing.....	104
9.2.5	Sensors/terminals, bearing bracket	105
9.2.6	Bearing bracket fastening	108
9.2.7	Screwed connection bellmouth/casing wear ring/pump bowl	109
9.2.8	Clearance adjusting screw	109
9.2.9	Impeller fastening elements, tapered connection	110
9.2.10	Impeller fastening elements, cylindrical connection	110
9.2.11	Grub screw in the impeller	111
9.2.12	Mechanical seal with covered spring	111
9.2.13	Float switch.....	112
9.2.14	Lubricant inlet	112
9.2.15	Lubricant drain / leakage chamber	113
9.2.16	Labels/plates	113
9.2.17	Version with adapter	114
9.3	Cable bundle	115
9.4	Wiring diagrams	117
9.4.1	Wiring diagram for the power cable	117
9.4.2	Wiring diagrams for the sensors	118
9.4.2.1	Pump set with standard sensors	118
9.4.2.2	Pump set with sensor system	119
9.5	Flamepaths on explosion-proof motors	121
9.6	Dimensions.....	123
9.6.1	Dimensions [mm].....	123

9.7	General arrangement drawings [mm].....	125
9.7.1	Installation types BU/BUS.....	125
9.7.2	Installation type BG.....	129
9.7.3	Installation types CU/CUS.....	132
9.7.4	Installation type CG.....	136
9.7.5	Installation types DU/DUS.....	139
9.7.6	Installation type DG	143
9.7.7	Dimensions of the flow-straightening vane.....	146
10	EU Declaration of Conformity.....	148
11	Certificate of Decontamination	150
	Index.....	151

Glossary

Certificate of decontamination

A certificate of decontamination is enclosed by the customer when returning the product to the manufacturer to certify that the product has been properly drained to eliminate any environmental and health hazards arising from components in contact with the fluid handled.

Close-coupled design

Motor directly fitted to the pump via a flange or a drive lantern

ECB (ever clean blade) design

Self-cleaning vane profile

Submersible pump in discharge tube

A submersible motor pump which is completely submerged and suspended in a discharge tube

1 General

1.1 Principles

This operating manual is valid for the type series and variants indicated on the front cover.

The operating manual describes the proper and safe use of this equipment in all phases of operation.

The name plate indicates the type series and size, the main operating data, the order number and the order item number. The order number and order item number clearly identify the pump set and serve as identification for all further business processes.

In the event of damage, immediately contact your nearest KSB service facility to maintain the right to claim under warranty.

1.2 Installation of partly completed machinery

To install partly completed machinery supplied by KSB refer to the sub-sections under Servicing/Maintenance.

1.3 Target group

This operating manual is aimed at the target group of trained and qualified specialist technical personnel. (⇒ Section 2.3, Page 10)

1.4 Other applicable documents

Table 1: Overview of other applicable documents

Document	Contents
Data sheet	Description of the technical data of the pump (set)
Hydraulic characteristic curve	Characteristic curves showing head, NPSH required, efficiency and power input
General assembly drawing ¹⁾	Sectional drawing of the pump set
Sub-supplier product literature ¹⁾	Operating manuals and other product literature describing accessories and integrated machinery components
Spare parts lists ¹⁾	Description of spare parts

For accessories and/or integrated machinery components, observe the relevant manufacturer's product literature.

1.5 Symbols







Table 2: Symbols used in this manual

Symbol	Description
✓	Conditions which need to be fulfilled before proceeding with the step-by-step instructions
▷	Safety instructions
⇒	Result of an action
⇔	Cross-references
1. 2.	Step-by-step instructions
	Note Recommendations and important information on how to handle the product

¹⁾ If included in agreed scope of supply

1.6 Key to safety symbols/markings

Table 3: Definition of safety symbols/markings

Symbol	Description
	DANGER This signal word indicates a high-risk hazard which, if not avoided, will result in death or serious injury.
	WARNING This signal word indicates a medium-risk hazard which, if not avoided, could result in death or serious injury.
	CAUTION This signal word indicates a hazard which, if not avoided, could result in damage to the machine and its functions.
	Explosion protection This symbol identifies information about avoiding explosions in potentially explosive atmospheres in accordance with EU Directive 2014/34/EU (ATEX).
	General hazard In conjunction with one of the signal words this symbol indicates a hazard which will or could result in death or serious injury.
	Electrical hazard In conjunction with one of the signal words this symbol indicates a hazard involving electrical voltage and identifies information about protection against electrical voltage.
	Machine damage In conjunction with the signal word CAUTION this symbol indicates a hazard for the machine and its functions.



2 Safety

All the information contained in this section refers to hazardous situations.

In addition to the present general safety information the action-related safety information given in the other sections must be observed.

2.1 General

- This operating manual contains general installation, operating and maintenance instructions that must be observed to ensure safe operation of the system and prevent personal injury and damage to property.
- Comply with all the safety instructions given in the individual sections of this operating manual.
- The operating manual must be read and understood by the responsible specialist personnel/operators prior to installation and commissioning.
- The contents of this operating manual must be available to the specialist personnel at the site at all times.
- Information and markings attached directly to the product must always be complied with and kept in a perfectly legible condition at all times. This applies to, for example:
 - Arrow indicating the direction of rotation
 - Markings for connections
 - Name plate
- The operator is responsible for ensuring compliance with all local regulations not taken into account.

2.2 Intended use

- The pump (set) must only be operated in the fields of application and within the use limits specified in the other applicable documents.
- Only operate pumps/pump sets which are in perfect technical condition.
- Do not operate the pump (set) in partially assembled condition.
- Only use the pump to handle the fluids described in the data sheet or product literature of the pump model or variant.
- Never operate the pump without the fluid to be handled.
- Observe the limits for continuous duty specified in the data sheet or product literature (Q_{\min} and Q_{\max}) (to prevent damage such as shaft fracture, bearing failure, mechanical seal damage, etc).
- Observe the minimum flow rate and maximum flow rate indicated in the data sheet or product literature (to prevent overheating, mechanical seal damage, cavitation damage, bearing damage, etc).
- Always operate the pump (set) in the direction of rotation it is intended for.

2.3 Personnel qualification and training

All personnel involved must be fully qualified to transport, install, operate, maintain and inspect the machinery this manual refers to.

The responsibilities, competence and supervision of all personnel involved in transport, installation, operation, maintenance and inspection must be clearly defined by the operator.

Deficits in knowledge must be rectified by means of training and instruction provided by sufficiently trained specialist personnel. If required, the operator can commission the manufacturer/supplier to train the personnel.

Training on the pump (set) must always be supervised by technical specialist personnel.

2.4 Consequences and risks caused by non-compliance with this manual

- Non-compliance with these operating instructions will lead to forfeiture of warranty cover and of any and all rights to claims for damages.
- Non-compliance can, for example, have the following consequences:
 - Hazards to persons due to electrical, thermal, mechanical and chemical effects and explosions
 - Failure of important product functions
 - Failure of prescribed maintenance and servicing practices
 - Hazard to the environment due to leakage of hazardous substances

2.5 Safety awareness

In addition to the safety information contained in this operating manual and the intended use, the following safety regulations shall be complied with:

- Accident prevention, health regulations and safety regulations
- Explosion protection regulations
- Safety regulations for handling hazardous substances
- Applicable standards, directives and laws

2.6 Safety information for the operator/user

- Fit protective equipment (e.g. contact guards) supplied by the operator for hot, cold or moving parts, and check that the equipment functions properly.
- Do not remove any protective equipment (e.g. contact guards) during operation.
- Provide the personnel with protective equipment and make sure it is used.
- Contain leakages (e.g. at the shaft seal) of hazardous fluids handled (e.g. explosive, toxic, hot) so as to avoid any danger to persons and the environment. Adhere to all relevant laws.
- Eliminate all electrical hazards. (In this respect refer to the applicable national safety regulations and/or regulations issued by the local energy supply companies.)
- If stopping the pump does not increase potential risk, fit an emergency-stop control device in the immediate vicinity of the pump (set) during pump set installation.

2.7 Safety information for maintenance, inspection and installation

- Modifications or alterations of the pump (set) are only permitted with the manufacturer's prior consent.
- Use only original spare parts or parts/components authorised by the manufacturer. The use of other parts/components can invalidate any liability of the manufacturer for resulting damage.
- The operator ensures that maintenance, inspection and installation are performed by authorised, qualified specialist personnel who are thoroughly familiar with the manual.
- Only carry out work on the pump (set) during standstill of the pump.
- Only perform work on the pump set when it has been disconnected from the power supply (de-energised).
- The pump (set) must have cooled down to ambient temperature.
- Pump pressure must have been released and the pump must have been drained.

- When taking the pump set out of service always adhere to the procedure described in the manual. (⇒ Section 6.3, Page 52)
- Decontaminate pumps which handle fluids posing a health hazard.
- As soon as the work has been completed, re-install and re-activate any safety-relevant devices and protective devices. Before returning the product to service, observe all instructions on commissioning. (⇒ Section 6.1, Page 48)

2.8 Unauthorised modes of operation

Never operate the pump (set) outside the limits stated in the data sheet and in this operating manual.

The warranty relating to the operating reliability and safety of the pump (set) supplied is only valid if the equipment is used in accordance with its intended use.

2.9 Explosion protection

Always observe the information on explosion protection given in this section when operating an explosion-proof pump set.

Sections of the manual marked by the symbol opposite apply to explosion-proof pump sets also when temporarily operated outside potentially explosive atmospheres.

Pumps / pump sets must not be used in potentially explosive atmospheres unless marked as explosion-proof **and** identified as such in the data sheet.

Special conditions apply to the operation of explosion-proof pump sets in accordance with EU Directive 2014/34/EU (ATEX).

Especially adhere to the sections in this manual marked with the symbol opposite. The explosion-proof status of the pump is only assured if the pump is used in accordance with its intended use.

Never operate the product outside the limits stated in the data sheet and on the name plate.

Prevent impermissible modes of operation.

2.9.1 Repair

Special regulations apply to repair work on explosion-proof pumps. Modifications or alterations of the pump set can affect explosion protection and are only permitted after consultation with the manufacturer.

Repair work at the flameproof joints must only be performed in accordance with the manufacturer's instructions. Repair to the values in Table 2 of EN 60079-1 is not permitted.



3 Transport/Storage/Disposal

3.1 Checking the condition upon delivery

1. On transfer of goods, check each packaging unit for damage.
2. In the event of in-transit damage, assess the exact damage, document it and notify KSB or the supplying dealer and the insurer about the damage in writing immediately.

3.2 Transport

	DANGER
	<p>Improper transport Danger to life from falling parts! Damage to the pump set!</p> <ul style="list-style-type: none"> ▷ Use the attachment point provided for attaching the lifting accessory. ▷ Never lift the pump set by the electric cables. ▷ Use the lifting chain/rope included in the scope of supply exclusively for lowering or lifting the pump set into/out of the pump sump. ▷ Securely attach the lifting chain/rope to the pump and crane. ▷ Use tested, marked and approved lifting accessories only. ▷ Observe the regional transport regulations. ▷ Observe the documentation of the lifting accessory manufacturer. ▷ The load-carrying capacity of the lifting accessory must be higher than the weight indicated on the name plate of the pump set to be lifted. Take into account any additional system components to be lifted. ▷ Maintain a safe distance during lifting operations (load may swing when being lifted).

3.2.1 Transporting the delivered pump set to the place of installation

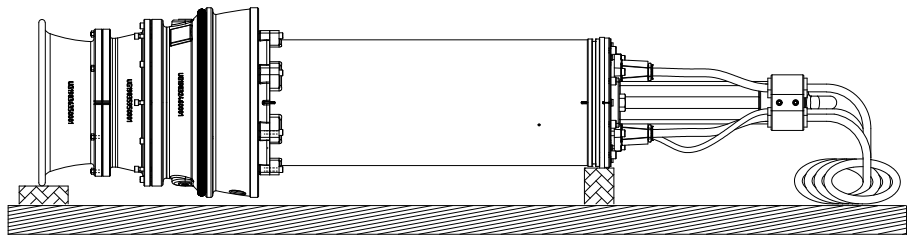







Fig. 1: Transporting the pump set in its original packaging

- The pump set is supplied in a horizontal position on a suitable transport support.
- Use suitable lifting equipment to transport the pump set in its original packaging to its place of installation.
 Observe the marked centres of gravity and/or attachment points on the transport boxes!
 For the weight refer to the name plate or data sheet.

3.2.2 Placing the pump set in a vertical or horizontal position

	WARNING
	<p>Pump set tilting Risk of squashing hands and feet!</p> <ul style="list-style-type: none"> ▷ Suspend or support the pump set.

	<p>⚠ WARNING</p> <p>Placing the pump set on unsecured and uneven surfaces Personal injury and damage to property!</p> <ul style="list-style-type: none"> ▷ Always place the pump set on a solid and level surface with the pump set in a vertical position and the motor on top. ▷ Only place the pump set on a surface of sufficient load-carrying capacity. ▷ Use appropriate means to secure the pump set against tilting or tipping over. ▷ Refer to the weights given in the data sheet/on the name plate.
	<p>⚠ WARNING</p> <p>Incorrect handling of the electric cable Personal injury and damage to property!</p> <ul style="list-style-type: none"> ▷ Secure electric cables against falling down. ▷ Avoid electric cables being laid on surfaces without fastening. ▷ When moving the pump set keep at a safe distance to the electric cables.
	<p>⚠ WARNING</p> <p>Improper handling when placing the pump set in a vertical/horizontal position Personal injury and damage to property!</p> <ul style="list-style-type: none"> ▷ Use one or two pieces of lifting equipment, depending on the pump (set) size. ▷ Use appropriate means to secure the pump set against tilting, tipping over or rolling off. ▷ Maintain a safe distance during lifting operations (load may swing when being lifted). ▷ Use additional supports for the transport holder to secure it against tilting.
	<p>⚠ WARNING</p> <p>Improper lifting/moving of heavy assemblies or components Personal injury and damage to property!</p> <ul style="list-style-type: none"> ▷ Use suitable transport devices, lifting equipment and lifting tackle to move heavy assemblies or components.
	<p>CAUTION</p> <p>Improper storage Damage to the electric cables!</p> <ul style="list-style-type: none"> ▷ Support the electric cables at the cable gland to prevent permanent deformation. ▷ Only remove the protective caps from the electric cables at the time of installation.

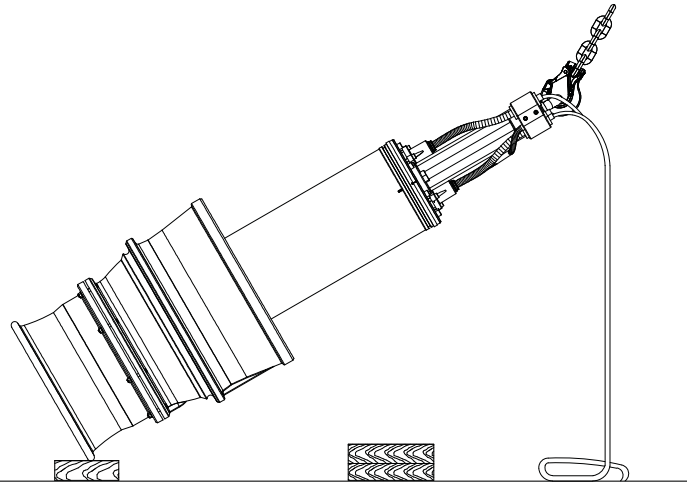

Fig. 2: Pulling the pump set upright with one crane

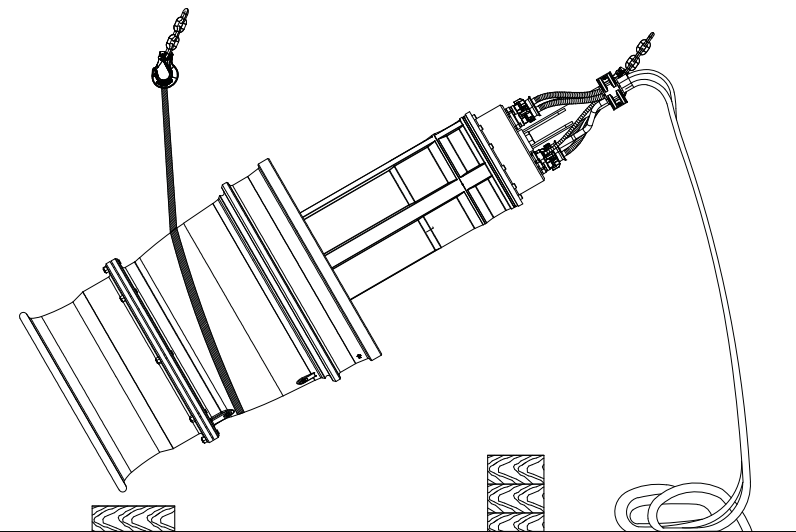

Fig. 3: Pulling the pump set upright with two cranes

✓ Suitable lifting equipment has been selected (e.g. crane).

1. a) For one piece of lifting equipment: Attach the eyehook to the bail of the pump set.
 b) For two pieces of lifting equipment: Attach one eyehook to the bail of the pump set. **Then** suitably loop a rope around the pump set and attach this loop to the second crane hook.
2. Lift the pump set with the lifting equipment.
 - ⇒ Guiding the pump set over the edge of the bellmouth or pump casing is only permissible on a wooden base!
 - ⇒ Protect the power cable against kinking!
3. Place the pump set on a level, clean surface and protect it against tilting, tipping over or rolling off.

3.2.3 Transporting the pump set

	<p>⚠ WARNING</p>
	<p>Incorrect positioning/placing down Personal injury and damage to property!</p> <ul style="list-style-type: none"> ▷ Position the pump set vertically with the motor on top. ▷ Use appropriate means to secure the pump set against tilting and tipping over. ▷ Refer to the weights given in the data sheet/on the name plate.

	<p>! WARNING</p>
	<p>Incorrect handling of the electric cable Personal injury and damage to property!</p> <ul style="list-style-type: none"> ▷ Secure electric cables against falling down. ▷ Avoid electric cables being laid on surfaces without fastening. ▷ When moving the pump set keep at a safe distance to the electric cables.
	<p>! WARNING</p>
	<p>Improper lifting/moving of heavy assemblies or components Personal injury and damage to property!</p> <ul style="list-style-type: none"> ▷ Use suitable transport devices, lifting equipment and lifting tackle to move heavy assemblies or components.
	<p>! WARNING</p>
	<p>Improper handling when placing the pump set in a vertical/horizontal position Personal injury and damage to property!</p> <ul style="list-style-type: none"> ▷ Use one or two pieces of lifting equipment, depending on the pump (set) size. ▷ Use appropriate means to secure the pump set against tilting, tipping over or rolling off. ▷ Maintain a safe distance during lifting operations (load may swing when being lifted). ▷ Use additional supports for the transport holder to secure it against tilting.

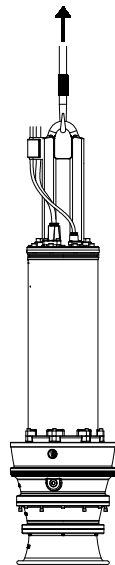

Fig. 4: Transporting the pump set in a vertical position

Use suitable lifting equipment to transport the pump set in the illustrated position.

3.3 Storage/preservation

If commissioning is to take place some time after delivery, we recommend that the following measures be taken:

Store the pump set as follows:

- In its original packaging: in a horizontal position
- Without packaging: in a vertical position with the motor on top





	<p>! WARNING</p> <p>Pump set tilting Risk of squashing hands and feet!</p> <ul style="list-style-type: none"> ▷ Suspend or support the pump set.
	<p>CAUTION</p> <p>Improper storage Damage to the electric cables!</p> <ul style="list-style-type: none"> ▷ Support the electric cables at the cable gland to prevent permanent deformation. ▷ Only remove the protective caps from the electric cables at the time of installation.
	<p>CAUTION</p> <p>Damage during storage due to humidity, dirt or vermin Corrosion/contamination of pump (set)!</p> <ul style="list-style-type: none"> ▷ For outdoor storage cover the pump (set) or the packaged pump (set) and accessories with waterproof material.
	<p>CAUTION</p> <p>Wet, contaminated or damaged openings and connections Leakage or damage to the pump!</p> <ul style="list-style-type: none"> ▷ Clean and cover pump openings and connections as required prior to putting the pump into storage.

Table 4: Ambient conditions for storage

Ambient condition	Value
Relative humidity	5 % to 85 % (non-condensing)
Ambient temperature	-20 °C to +70 °C

- Store the pump set in dry, vibration-free conditions and, if possible, in its original packaging.
1. Rotate the impeller by hand once every three months.
 2. Spray-coat the inside wall of the pump casing and, in particular, the impeller clearance areas with a preservative.



	<p>NOTE</p> <p>Observe the manufacturer's instructions for application/removal of the preservative.</p>
---	--

3.4 Return to supplier

1. Drain the pump properly. (⇒ Section 7.3.2, Page 61)
2. Flush and clean the pump, particularly if it has been used for handling noxious, explosive, hot or other hazardous fluids.
3. If the pump has handled fluids whose residues could lead to corrosion damage in the presence of atmospheric humidity or could ignite upon contact with oxygen, the pump must also be neutralised, and anhydrous inert gas must be blown through the pump to ensure drying.
4. Always complete and enclose a certificate of decontamination when returning the pump.
Indicate any safety measures and decontamination measures taken.
(⇒ Section 11, Page 150)

	NOTE
	<p>If required, a blank certificate of decontamination can be downloaded from the following web site: www.ksb.com/certificate_of_decontamination</p>

3.5 Disposal

	 WARNING
	<p>Fluids handled, consumables and supplies which are hot and/or pose a health hazard</p> <p>Hazard to persons and the environment!</p> <ul style="list-style-type: none"> ▷ Collect and properly dispose of flushing fluid and any fluid residues. ▷ Wear safety clothing and a protective mask if required. ▷ Observe all legal regulations on the disposal of fluids posing a health hazard.

1. Dismantle the pump (set).
Collect greases and other lubricants during dismantling.
2. Separate and sort the pump materials, e.g. by:
 - Metals
 - Plastics
 - Electronic waste
 - Greases and other lubricants
3. Dispose of materials in accordance with local regulations or in another controlled manner.

4 Description of the Pump (Set)

4.1 General description

- Submersible pump in discharge tube

Pump set for handling river water and stormwater, pre-screened domestic and industrial waste water as well as activated sludge

4.2 Designation

Example: AmaCan DB3 600-420/1304UTG1 IE3

Table 5: Designation key

Code	Description	
AmaCan	Type series	
D	Impeller type	
	D	Open mixed-flow multi-vane impeller
B	Impeller variants	
	A	
	B	
3	Number of vanes	
	2	
	3	
600	Nominal diameter of the discharge tube [mm]	
420	Nominal impeller diameter [mm]	
130	Motor size	
4	Number of motor poles	
UT	Motor version	
	UT	Not explosion-proof
	XT	Explosion protection  II2G Ex db h IIB T3 Gb
G1	Material variant	
	G1	Grey cast iron, standard material variant
	G2	Cast iron, casing wear ring made of stainless steel
	G3	Grey cast iron with Zn anodes, casing wear ring made of stainless steel, shaft made of stainless steel 1.4057
IE3	Motor efficiency classification ²⁾	
	_ ³⁾	No efficiency classification
	IE3	Premium Efficiency

²⁾ The IEC 60034-30 standard is not binding for submersible motor pumps. Efficiencies are calculated / determined by analogy with the measurement method specified in IEC 60034-2. The marking is used for submersible motors that achieve efficiency levels similar to those of standard motors acc. to the IEC 60034-30 standard.

³⁾ Blank

4.3 Name plate

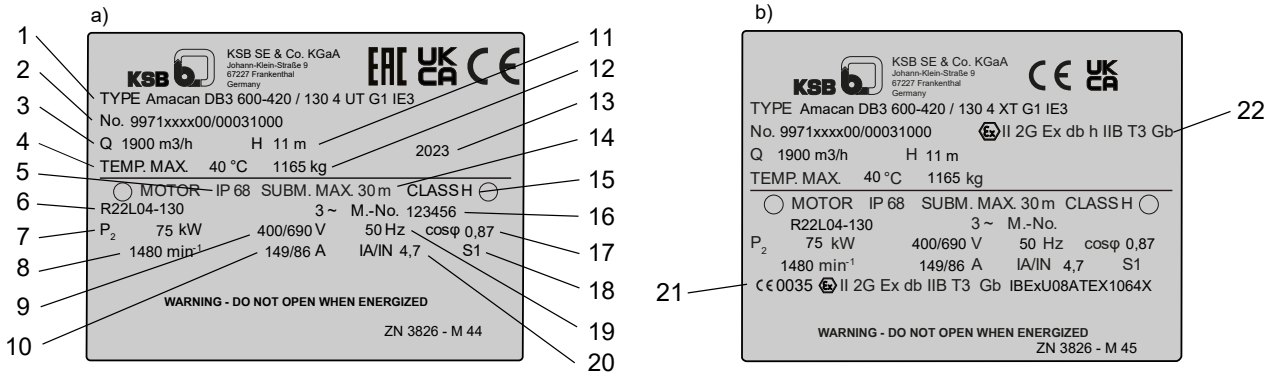

Fig. 5: Name plate (example) a) Standard pump set b) Explosion-proof pump set

1	Designation	2	KSB order number
3	Flow rate	4	Maximum fluid temperature and ambient temperature
5	Enclosure	6	Motor type
7	Rated power	8	Rated speed
9	Rated voltage	10	Rated current
11	Head	12	Total weight
13	Year of construction	14	Maximum submergence ∇
15	Thermal class of winding insulation	16	Motor number
17	Power factor at rated operating point	18	Duty type
19	Rated frequency	20	Starting current ratio
21	ATEX marking for the submersible motor	22	ATEX marking for the pump set

4.4 Design details

Design

- Fully floodable submersible pump in discharge tube (submersible motor pump)
- Not self-priming
- Close-coupled design
- Single-stage
- Vertical installation

Drive

- Three-phase asynchronous squirrel-cage motor
- Enclosure: IP68 to EN/IEC 60529
- Type of protection Ex db IIB (applies to explosion-proof pump sets only)

Shaft seal

- Two bi-directional mechanical seals in tandem arrangement, with liquid reservoir
- Leakage chamber

Impeller type

- Open, mixed-flow multi-vane impeller in ECB (ever clean blade) design⁴⁾

Bearings

- Grease-lubricated rolling element bearings

⁴ ECB (EverCleanBlade) = self-cleaning blade contour

Monitoring equipment

Various sensor packages are available for pump/pump set monitoring:

- **Basic**
 - Motor temperature monitoring (PTC thermistor)
 - Leakage sensor in the motor space
 - Mechanical seal leakage sensor (float switch)
 - Bearing temperature monitoring, pump end (Pt100)
- **Basic+**
 - Motor temperature monitoring (PTC thermistor)
 - Leakage sensor in the motor space
 - Mechanical seal leakage sensor (float switch)
 - Bearing temperature monitoring, drive end (Pt100)
 - Bearing temperature monitoring, pump end (Pt100)
- **Premium**
 - Motor temperature monitoring (PTC thermistor)
 - Leakage sensor in the motor space
 - Mechanical seal leakage sensor (float switch)
 - Bearing temperature monitoring, drive end (Pt100)
 - Bearing temperature monitoring, pump end (Pt100)
 - Vibration monitoring
 - Motor temperature measurement (Pt100)

The sensor information can optionally be evaluated via AmaControl using the live diagnosis function:

- Directly on site with the KSB INTspecter app
- In additional external systems via ModBus

4.5 Installation types

Table 6: Overview of installation types

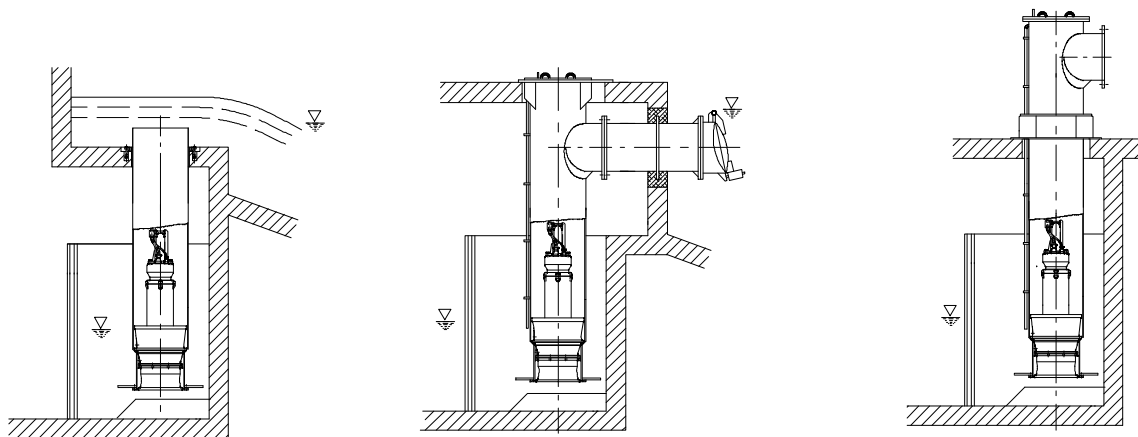

BU⁵/BUS⁶ discharge tube
Overflow design with open intake chamber

CU⁵/CUS⁶ discharge tube
Underfloor discharge with open intake chamber

DU⁵/DUS⁶ discharge tube
Above-floor discharge nozzle with open intake chamber

1581.85/01-EN

⁵ Design without suction umbrella

⁶ Design with suction umbrella

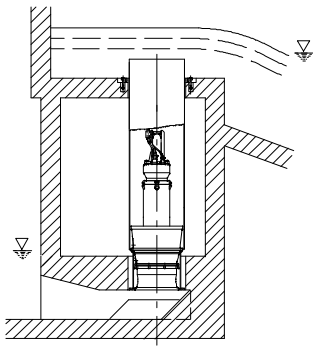

BG⁵ discharge tube

Overflow design for installation in covered intake chamber for low suction-side water levels

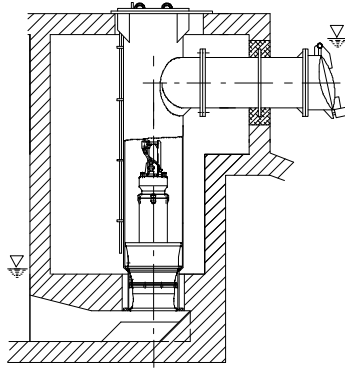

CG⁵ discharge tube

Design with underfloor discharge for installation in covered intake chamber for low suction-side water levels

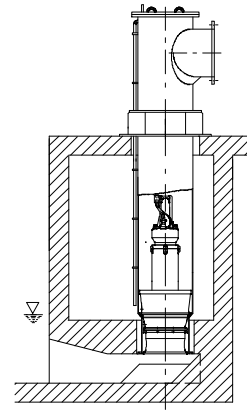

DG⁵ discharge tube

Design with above-floor discharge nozzle for installation in covered intake chamber for low suction-side water levels

4.6 Configuration and function

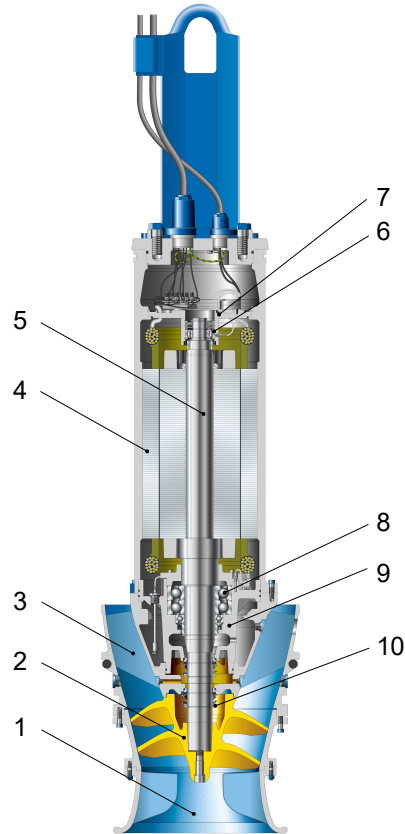

Fig. 6: Configuration and function

1	Suction nozzle (bellmouth)	2	Impeller
3	Pump bowl	4	Electric motor
5	Shaft	6	Bearing, motor end
7	Bearing bracket	8	Bearing, pump end
9	Bearing housing, pump end	10	Shaft seal

Design The pump is designed with an axial fluid inlet and an axial outlet. The hydraulic system sits on the extended motor shaft. The shaft runs in common bearings.

Function The fluid enters the pump axially via a suction nozzle (bellmouth) (1) and is accelerated outward in a rotating flow by the rotating impeller (2). The required energy is transmitted from the electric motor (4) to the impeller (2) via the shaft (5). In the pump bowl (3) the kinetic energy of the fluid is converted into pressure energy and the rotational movement of the fluid flow is diverted in axial direction. The shaft passage through the casing is sealed towards the fluid with a shaft seal (10). The shaft (5) runs in two rolling element bearings (6 and 8), which are supported by the bearing housing (9) and the bearing bracket (7).

Sealing The pump is sealed by two bi-directional mechanical seals in tandem arrangement. A lubricant reservoir in-between the seals ensures cooling and lubrication of the mechanical seals.

Monitoring equipment Standard

- Sensor package Basic

Option

- Sensor package Basic+
- Sensor package Premium with sensor system

4.7 Scope of supply

Depending on the model, the following items are included in the scope of supply:

- Pump set complete with power cables
- O-ring
- Back-up name plate

Optional accessories:

- Support rope
- Accessories for installing the cable guide:
 - Fitting
 - Turnbuckle
 - Support
 - Shackle
 - Cable clamps
- Cable support sleeves
- Discharge tube
- Flow-straightening vane to prevent floor vortices
- AmaControl 5 monitoring system



NOTE





A separate name plate is included in the scope of supply. This name plate must be attached in a clearly visible position outside the place of installation, e.g. at the control panel, pipeline or mounting bracket.

4.8 Dimensions and weights

For dimensions and weights refer to the name plate or data sheet of the pump set.

5 Installation at Site

5.1 Safety regulations

	<p>⚠ DANGER</p> <p>Improper installation in potentially explosive atmospheres Explosion hazard! Damage to the pump set!</p> <ul style="list-style-type: none"> ▸ Comply with the applicable local explosion protection regulations. ▸ Observe the information in the data sheet and on the name plates of pump and motor.
	<p>⚠ DANGER</p> <p>Improper transport Danger to life from falling parts! Damage to the pump set!</p> <ul style="list-style-type: none"> ▸ Use the attachment point provided for attaching the lifting accessory. ▸ Never lift the pump set by the electric cables. ▸ Use the lifting chain/rope included in the scope of supply exclusively for lowering or lifting the pump set into/out of the pump sump. ▸ Securely attach the lifting chain/rope to the pump and crane. ▸ Use tested, marked and approved lifting accessories only. ▸ Observe the regional transport regulations. ▸ Observe the documentation of the lifting accessory manufacturer. ▸ The load-carrying capacity of the lifting accessory must be higher than the weight indicated on the name plate of the pump set to be lifted. Take into account any additional system components to be lifted. ▸ Maintain a safe distance during lifting operations (load may swing when being lifted).
	<p>⚠ DANGER</p> <p>Persons in the intake chamber during pump set operation Electric shock! Risk of injury!</p> <ul style="list-style-type: none"> ▸ Never start up the pump set when there are persons in the intake chamber.
	<p>⚠ WARNING</p> <p>Impermissible solid objects (tools, screws/bolts or similar) in the pump sump/inlet tank during pump start-up Personal injury and damage to property!</p> <ul style="list-style-type: none"> ▸ Check the pump sump/inlet tank for impermissible solid objects before flooding, and remove, if necessary.

5.2 Checks to be carried out prior to installation

5.2.1 Checking the structural requirements

All structural work required must have been prepared in accordance with the dimensions stated in the outline drawing / general arrangement drawing.

5.2.2 Checking the operating data

Before inserting the pump set into the discharge tube, verify the data on the name plate against the data given in the purchase order and the system data.

Back-up name plate

KSB's scope of supply includes a separate name plate attached to the end of the pump cable which indicates the pump and motor data.

1. Attach this name plate in a clearly visible position outside the discharge tube, e.g. at the control cabinet, pipeline or mounting bracket.

5.2.3 Checking the lubricant of the mechanical seal

The lubricant reservoir is filled at the factory with an environmentally-friendly, non-toxic lubricant.

The pump set is supplied in a horizontal position on a suitable transport support.

Visual inspection for signs of oil leakage

1. If no oil leakage is visible in the area of pump bowl, impeller or transport support, the lubricant reservoir is filled properly.
2. If oil leakage is visible in the area of pump bowl, impeller or transport support, top up the lubricant.

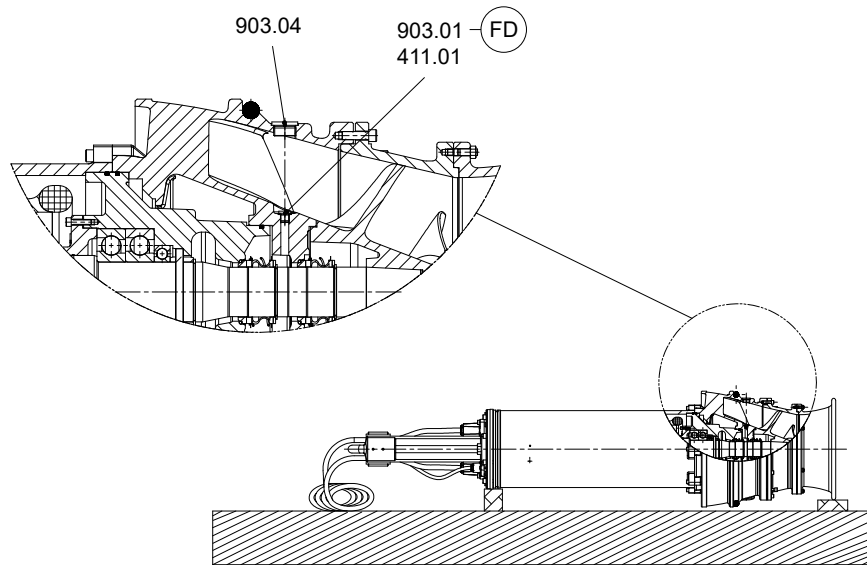

Fig. 7: Checking the lubricant level

Table 7: Symbols key

Symbol	Description
FD	Always apply a liquid sealant (e.g. Hylomar SQ32M) to sealing surfaces marked with this symbol.

1. Place the pump set down in a horizontal position. Secure it against rolling away. (⇒ Section 3.2.2, Page 13)
2. When placing it down, make sure that screw plug 903.04 is on top.
 - ⇒ Screw plug 903.04 is marked with label/plate 970.04 (oil filler plug).
3. Remove screw plug 903.04.
4. Remove screw plug 903.01 and joint ring 411.01.
5. Shine a torch through the hole in the pump bowl to see the opening of the lubricant reservoir.
 - ⇒ If the lubricant level reaches the opening, fit screw plug 903.01 together with a new joint ring 411.01 as well as screw plug 903.04.
 - ⇒ If the lubricant level is below the opening, top up the lubricant.
6. Re-insert and tighten screw plug 903.01 with new joint ring 411.01.
7. Re-insert and tighten screw plug 903.04.

	NOTE
	<p>If more than 1 l of lubricant is required for topping up, this suggests a defect of the mechanical seals.</p>

5.2.4 Checking the direction of rotation

	⚠ DANGER
	<p>Pump set running dry Explosion hazard!</p> <ul style="list-style-type: none"> ▷ Check the direction of rotation of explosion-proof pump sets outside potentially explosive atmospheres.

	⚠ WARNING
	<p>Improper handling when placing the pump set in a vertical/horizontal position Personal injury and damage to property!</p> <ul style="list-style-type: none"> ▷ Use one or two pieces of lifting equipment, depending on the pump (set) size. ▷ Use appropriate means to secure the pump set against tilting, tipping over or rolling off. ▷ Maintain a safe distance during lifting operations (load may swing when being lifted). ▷ Use additional supports for the transport holder to secure it against tilting.

	⚠ WARNING
	<p>Improper positioning of pump set when checking the direction of rotation Personal injury and damage to property!</p> <ul style="list-style-type: none"> ▷ Use appropriate means to secure the pump set against tilting or tipping over.

	⚠ WARNING
	<p>Hands and/or foreign objects in the pump casing Risk of injuries, damage to the pump!</p> <ul style="list-style-type: none"> ▷ Never insert your hands or any other objects into the pump. ▷ Check that the inside of the pump is free from any foreign objects. ▷ Verify that the transport lock has been removed. ▷ Take suitable precautions (e.g. wear safety goggles).

	CAUTION
	<p>Pump set running dry Increased vibrations! Damage to mechanical seals and bearings!</p> <ul style="list-style-type: none"> ▷ Never operate the pump set for more than 60 seconds without the fluid handled.

Check the direction of rotation before installing the pump set, i.e. in dry condition.

1. Place the pump set in a vertical position on a level surface and secure it sufficiently against tipping over. (⇒ Section 3.2.2, Page 13)
2. Connect the pump set to the power supply and start it up.
3. Use one of the following options to check the direction of rotation:

- ⇒ 1. Look down into the pump bowl and check that the impeller is turning clockwise.
- ⇒ 2. Verify the direction of rotation of the impeller. The direction of rotation of the impeller must match the arrow indicating the direction of rotation on the pump bowl.
- 4. If the impeller rotates in the wrong direction of rotation, check and correct the electrical connection and the control system if applicable. Then check the direction of rotation again.
- 5. If the direction of rotation is correct, mark which core ends match which of the terminals in the control cabinet.
- 6. Disconnect the pump set from the power supply and secure it against unintentional start-up.



	WARNING
	<p>Unintentional starting of the pump set Risk of injury by moving components and shock currents!</p> <ul style="list-style-type: none"> ▷ Ensure that the pump set cannot be started unintentionally. ▷ Always make sure the electrical connections are disconnected before carrying out work on the pump set.

5.3 Lowering the pump set into the discharge tube

	DANGER
	<p>Improper transport Danger to life from falling parts! Damage to the pump set!</p> <ul style="list-style-type: none"> ▷ Use the attachment point provided for attaching the lifting accessory. ▷ Never lift the pump set by the electric cables. ▷ Use the lifting chain/rope included in the scope of supply exclusively for lowering or lifting the pump set into/out of the pump sump. ▷ Securely attach the lifting chain/rope to the pump and crane. ▷ Use tested, marked and approved lifting accessories only. ▷ Observe the regional transport regulations. ▷ Observe the documentation of the lifting accessory manufacturer. ▷ The load-carrying capacity of the lifting accessory must be higher than the weight indicated on the name plate of the pump set to be lifted. Take into account any additional system components to be lifted. ▷ Maintain a safe distance during lifting operations (load may swing when being lifted).

 	DANGER
	<p>Improper installation in potentially explosive atmospheres Explosion hazard! Damage to the pump set!</p> <ul style="list-style-type: none"> ▷ Comply with the applicable local explosion protection regulations. ▷ Observe the information in the data sheet and on the name plates of pump and motor.

1581.85/01-EN

	<p>⚠ WARNING</p>
	<p>Incorrect handling of the electric cable Personal injury and damage to property!</p> <ul style="list-style-type: none"> ▷ Secure electric cables against falling down. ▷ Avoid electric cables being laid on surfaces without fastening. ▷ When moving the pump set keep at a safe distance to the electric cables.
	<p>⚠ WARNING</p>
	<p>People falling into the unsecured discharge tube Risk of personal injury!</p> <ul style="list-style-type: none"> ▷ Take suitable precautions during the entire installation/removal process to protect people from falling into the open discharge tube. ▷ Fence off the work area appropriately.

5.3.1 Information for correct installation

The **flow-straightening vane** is **indispensable** for the inlet conditions of the pump set. It prevents the development of a submerged vortex (floor vortex) which could cause a drop in performance, for example. To provide optimum inlet conditions, observe the following information:

1. **Observe the structural requirements!**
 Install the flow-straightening vane concentrically below the discharge tube, see general arrangement drawing.

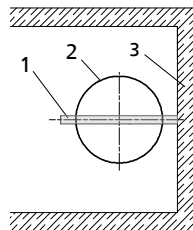

Fig. 8: Installation position of the flow-straightening vane

1	Flow-straightening vane	2	Discharge tube
3	Intake chamber		

2. **Observe the installation position of the pump set!**
 Lower the pump set into the discharge tube with the anti-swirl baffles (2) in the bellmouth aligned with the flow-straightening vane (3).
 Use the bail alignment of the pump set for orientation. The bail (1) is aligned with the anti-swirl baffles (2).

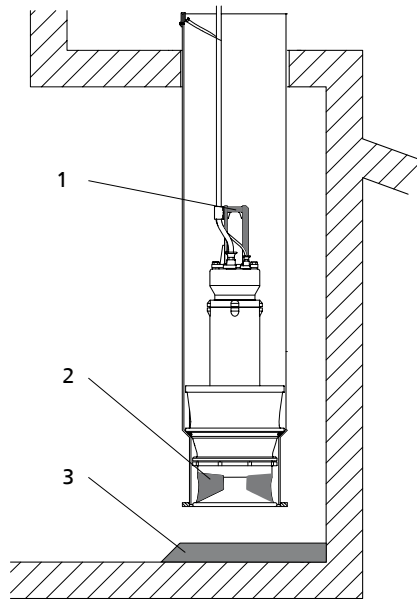

Fig. 9: Installation position of the pump set

1	Bail	2	Anti-swirl baffles
3	Flow-straightening vane		

5.3.2 Installation without support rope

	CAUTION
	<p>Incorrect installation Damage to the pump set!</p> <p>▷ Verify that the pump set is correctly seated in the discharge tube.</p>

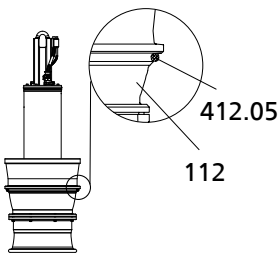

Fig. 10: Inserting the O-ring

Refer to and comply with the general arrangement drawing/outline drawing when installing the pump set.

1. If not already fitted, insert the supplied O-ring 412.05 into pump bowl 112.
2. Attach the crane hook to the bail of the pump set.
3. Centre the pump set above the discharge tube. Slowly lower the pump set into the discharge tube until it is seated in the recommended position. (⇒ Section 5.3.1, Page 28)
4. Pull the electric cables up by hand. Fasten them to the sump construction with a cable support sleeve if required. Do not lift the pump set out of its seat.

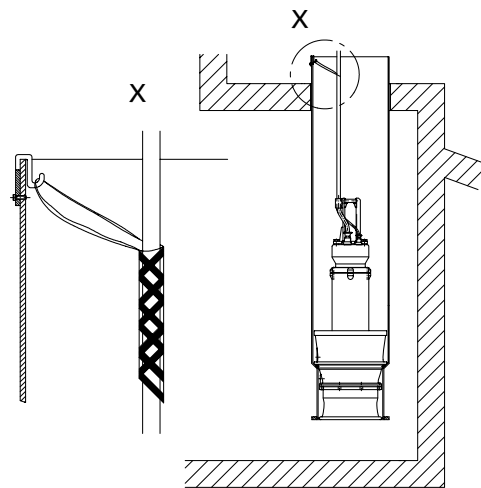

Fig. 11: Fastening the cable support sleeve

5.3.3 Installation with a support rope

Always refer to and comply with the general arrangement drawing/outline drawing when installing the pump set.

1. Prior to installing the pump set, visually inspect the support rope.
2. Do not exceed the permissible load-carrying capacity.

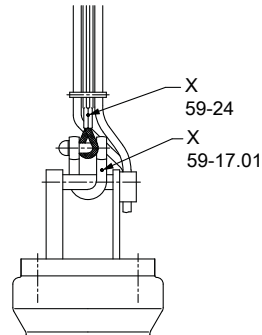

Fig. 12: X = indication of load-carrying capacity

59-24	Support rope
59-17.01	Shackle

	<p>CAUTION</p>
	<p>Incorrect installation Damage to the pump set!</p> <ul style="list-style-type: none"> ▷ Verify that the pump set is correctly seated in the discharge tube.
	<p>WARNING</p>
	<p>Pump set drops during the installation or removal process Personal injury and damage to property!</p> <ul style="list-style-type: none"> ▷ Never use the turnbuckle, shackle or discharge tube cover to lift the pump set. ▷ Always use lifting lug 59-47.
	<p>NOTE</p>
	<p>Prior to fitting the turnbuckle, check that the corresponding split pin has not been cracked and/or chipped. If damaged, always use a new split pin.</p>

- ✓ One piece of suitably sized lifting equipment with at least two fastening points or two suitably sized pieces of lifting equipment are available.
- ✓ The support rope has been visually inspected.
- ✓ The split pin of the turnbuckle has been checked for any damage.

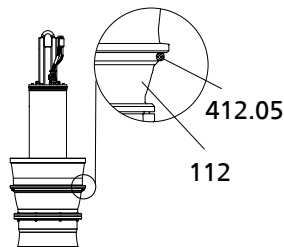

Fig. 13: Inserting the O-ring

1. If not already fitted, insert the supplied O-ring 412.05 into pump bowl 112.

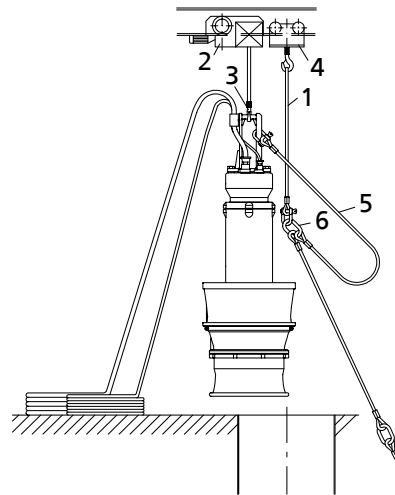

Fig. 14: Lifting and positioning the pump set

2. Secure the lifting chain or lifting rope (1) to the trolley (4) of the lifting equipment (2).
3. Attach the crane hook (3) to the bail.
4. Attach the support rope (5) to the bail by its shackle.
 - ⇒ Make sure that the support rope is arranged correctly. The free lifting lug (6) has to point away from the pump set.
 - ⇒ For a galvanised shackle, secure the pin at the shackle with Loctite 243.
 - ⇒ For a stainless steel shackle, undo and tighten the pin twice and secure it with Loctite 243.
5. Partially unwind the support rope and power cables.
6. Attach the first lifting lug (6) to the lifting rope (1).
7. Lower the pump set into the discharge tube until the bail is in an accessible position, protruding from the discharge tube, and the pump set is suspended from the lifting rope (1).
8. Securely cover the discharge tube except for a gap which allows work to continue.
9. Unclip the crane hook (3) of the lifting equipment from the bail. Move the lifting equipment up higher.

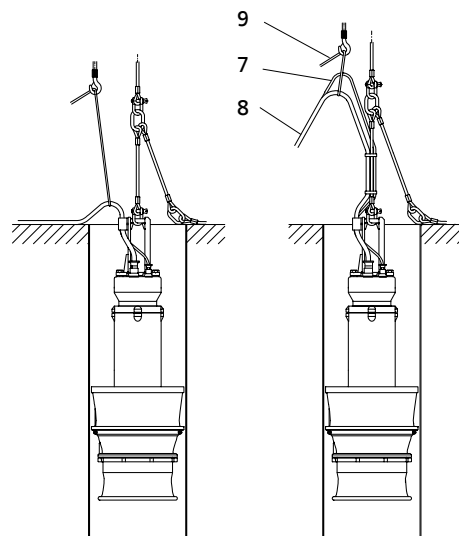

Fig. 15: Securing the power cable and sensor cable

10. Secure the sensor cable (7) and power cables (8) to the crane hook (3) of the lifting equipment with a manila rope (9).
11. Trim the spacer (a) to fit between the two ferrules.

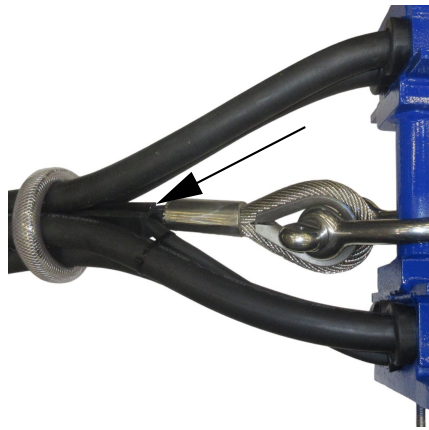

Fig. 16: Spacer at ferrule

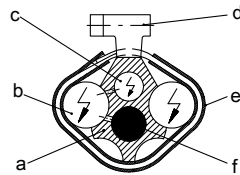

Fig. 17: Cross-section of the cable guide

12. Insert the support rope (f) and the sensor cable (c) into the spacer (a).
⇒ Make sure that the electric cables are in their respective ducts.
13. Tighten the electric cables with the manila rope running over the crane hook.
14. Insert the power cables (b) into the hollows of the spacer (a) and, starting from the bottom, firmly clamp the power cables with cable clamps (d) covered by a plastic sheath (e). Apply assembly paste to the cable clamps (d). Tighten the cable clamps hand-tight. Make sure the power cables are not crushed in this process (b) and are unable to slip out.



Fig. 18: Installation information for the cable clamps

15. Attach the crane hook (1) to the lifting lug (6) suspended from the lifting rope.
16. Attach the lifting rope to the next lifting lug.
17. Progressively lower the pump set into the discharge tube.
⇒ Secure the cable bundle with evenly spaced sheathed cable clamps until the pump set is suspended from the lifting rope (1).
18. Lay all power cables past the area of the lifting lug between the rope sections and fasten them to the rope section above.
19. Fit a heat shrink tube on any protruding sharp-edged rope ends (e.g. at the ferrule).
20. Repeat steps 17 to 19 until the pump set is located in its seat in the discharge tube.

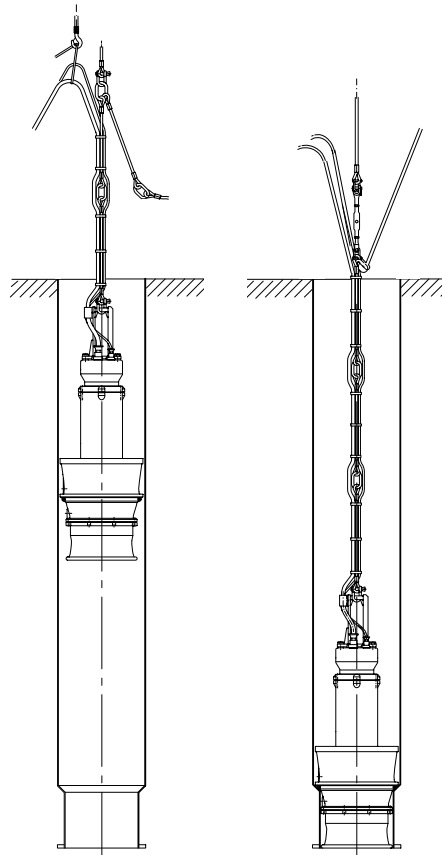

Fig. 19: Lowering the pump set

21. Attach the support rope with shackle and turnbuckle to a suspension loop (provided in the discharge tube or structure).
22. Secure the turnbuckle with a split pin.
 - ⇒ Insert the split pin. Bend back the two legs of the split pin in opposite directions.
 - ⇒ Attach the shackle of the turnbuckle to the upper thimble of the support rope. Do not attach the turnbuckle to the upper lifting lug.



Fig. 20: Shackle/turnbuckle

23. Tighten the turnbuckle until the cable bundle is tight but does not lift the pump set off its seat.
24. Secure the turnbuckle against loosening with two locknuts.
25. Unclick the crane hook of the lifting equipment from the lifting lug. Free the power cables from the manila rope and route them to the control cabinet.
26. Tie the upper loosely suspended lifting lug to the cable bundle.
27. Remove the safety cover from the discharge tube. Fit the cover. Seal the cable entries if any.

5.3.4 Installation with a support rope and support spacer

Always refer to and comply with the general arrangement drawing/outline drawing when installing the pump set.

1. Prior to installing the pump set, visually inspect the support rope.
2. Do not exceed the permissible load-carrying capacity.

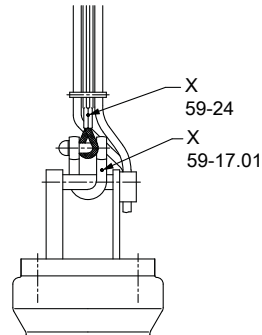

Fig. 21: X = indication of load-carrying capacity

59-24	Support rope
59-17.01	Shackle

	<p>CAUTION</p>
	<p>Incorrect installation Damage to the pump set!</p> <ul style="list-style-type: none"> ▷ Verify that the pump set is correctly seated in the discharge tube.
	<p>WARNING</p>
	<p>Pump set drops during the installation or removal process Personal injury and damage to property!</p> <ul style="list-style-type: none"> ▷ Never use the turnbuckle, shackle or discharge tube cover to lift the pump set. ▷ Always use lifting lug 59-47.
	<p>NOTE</p>
	<p>Prior to fitting the turnbuckle, check that the corresponding split pin has not been cracked and/or chipped. If damaged, always use a new split pin.</p>

- ✓ One piece of suitably sized lifting equipment with at least two fastening points or two suitably sized pieces of lifting equipment are available.
- ✓ The support has been pre-assembled and is available.
- ✓ The support rope has been visually inspected.
- ✓ The split pin of the turnbuckle has been checked for any damage.

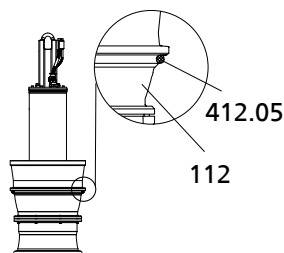

Fig. 22: Inserting the O-ring

1. If not already fitted, insert the supplied O-ring 412.05 into pump bowl 112.

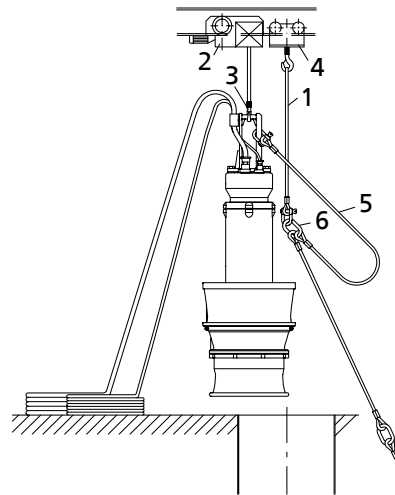

Fig. 23: Lifting and positioning the pump set

2. Secure the lifting chain or lifting rope (1) to the trolley (4) of the lifting equipment (2).
3. Attach the crane hook (3) to the bail.
4. Attach the support rope (5) to the bail by its shackle.
 - ⇒ Make sure that the support rope is arranged correctly. The free lifting lug (6) has to point away from the pump set.
 - ⇒ For a galvanised shackle, secure the pin at the shackle with Loctite 243.
 - ⇒ For a stainless steel shackle, undo and tighten the pin twice and secure it with Loctite 243.
5. Partially unwind the support rope and power cables.
6. Attach the first lifting lug (6) to the lifting rope (1).
7. Lower the pump set into the discharge tube until the bail is in an accessible position, protruding from the discharge tube, and the pump set is suspended from the lifting rope (1).
8. Securely cover the discharge tube except for a gap which allows work to continue.
9. Unclip the crane hook (3) of the lifting equipment from the bail. Move the lifting equipment up higher.

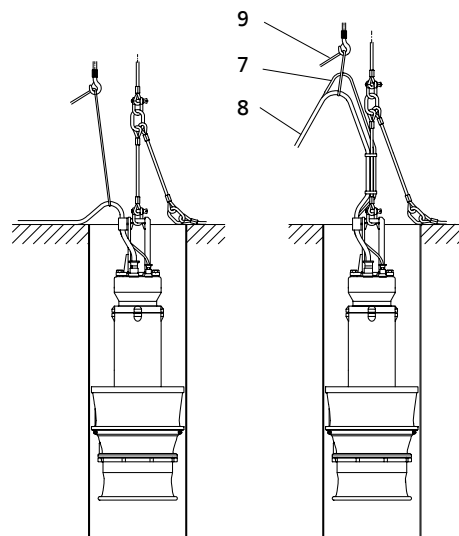

Fig. 24: Securing the power cable and sensor cable

10. Secure the sensor cable (7) and power cables (8) to the crane hook (3) of the lifting equipment with a manila rope (9).
11. Trim the spacer (a) to fit between the two ferrules.
 - ⇒ If a support is used in this section, adjust the spacer (a) accordingly.

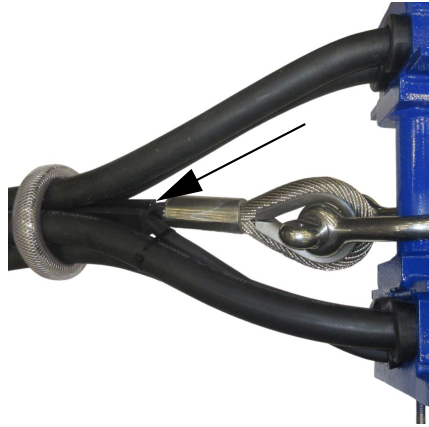

Fig. 25: Spacer at ferrule

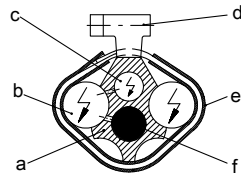

Fig. 26: Cross-section of the cable guide

12. Insert the support rope (f) and the sensor cable (c) into the spacer (a).
 - ⇒ Make sure that the electric cables are in their respective ducts.
 - ⇒ If a support is used in this rope section, observe the requirements (see general arrangement drawing).
13. Tighten the electric cables with the manila rope running over the crane hook.
14. Insert the power cables (b) into the hollows of the spacer (a) and, starting from the bottom, firmly clamp the power cables with cable clamps (d) covered by a plastic sheath (e). Apply assembly paste to the cable clamps (d). Tighten the cable clamps hand-tight. Make sure the power cables (b) are not crushed in this process and are unable to slip out.



Fig. 27: Installation information for the cable clamps

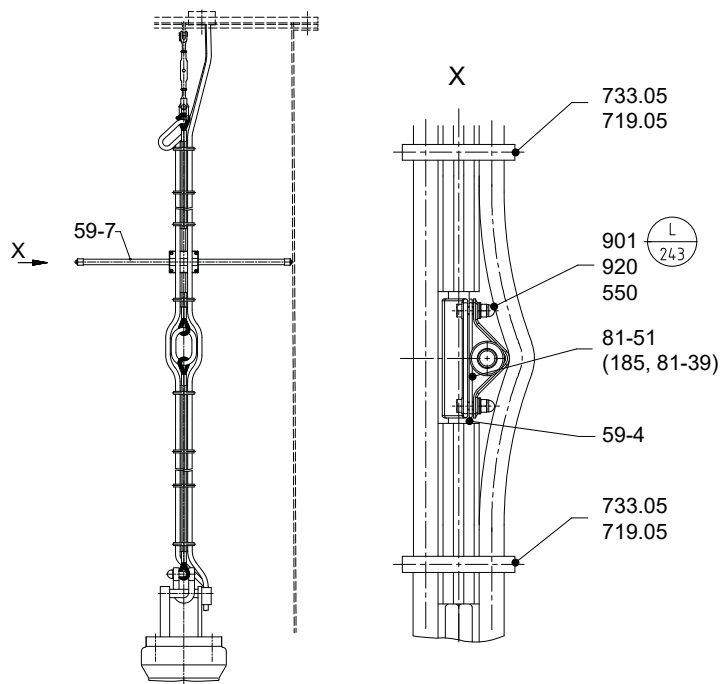

Fig. 28: Support rope with support

Table 8: Symbols key

Symbol	Description
	Always secure screwed connections marked with this symbol with Loctite 243 .

15. Undo the screwed connection at clamping element 81-51.
16. Place clamp 81-39 of the clamping element around the support rope.
17. Fasten plate 185 and clamp 81-39 of the GFRP rod to rope clamp 81-39 with hexagon head bolts 901, discs 550 and cap nuts 920. Tighten the connection and secure it with Loctite 243. (⇒ Section 9.3, Page 115)

	NOTE
	The support must be firmly clamped to the support rope, and the GFRP rod must be firmly clamped to the support. If necessary, pad out clamps 81-39.

18. Trim the spacer to fill the space between the support and the next ferrule.



Fig. 29: Spacer at support

19. Guide the power cables and sensor cable along the support to the next cable clamp. Pull them taut and secure them with the clamp.
 - ⇒ If several supports are fitted, arrange the supports offset from each other by 90°.
20. Attach the crane hook (1) to the lifting lug (6) suspended from the lifting rope.

21. Attach the lifting rope to the next lifting lug.
22. Progressively lower the pump set into the discharge tube.
 - ⇒ Secure the cable bundle with evenly spaced sheathed cable clamps until the pump set is suspended from the lifting rope (1).
23. Lay all power cables past the area of the lifting lug between the rope sections and fasten them to the rope section above.
24. Fit a heat shrink tube on any protruding sharp-edged rope ends (e.g. at the ferrule).
25. Repeat this procedure until the pump set is located in its seat in the discharge tube.

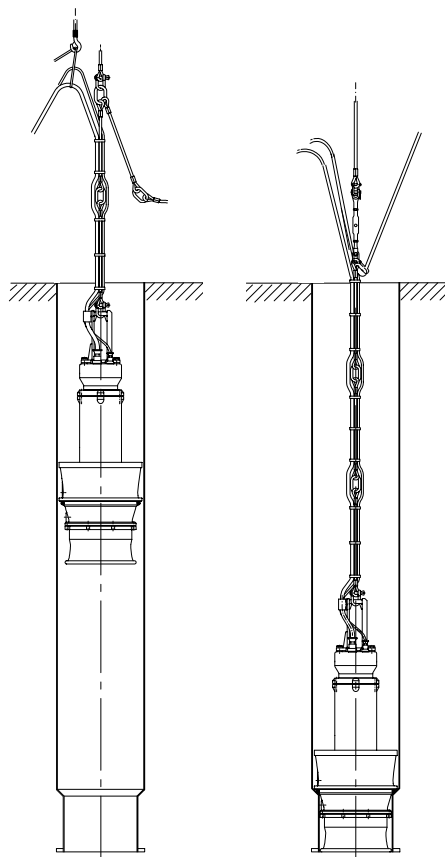

Fig. 30: Lowering the pump set

26. Attach the support rope with shackle and turnbuckle to a suspension loop (provided in the discharge tube or structure).
27. Secure the turnbuckle with a split pin.
 - ⇒ Insert the split pin. Bend back the two legs of the split pin in opposite directions.
 - ⇒ Attach the shackle of the turnbuckle to the upper thimble of the support rope. Do not attach the turnbuckle to the upper lifting lug.

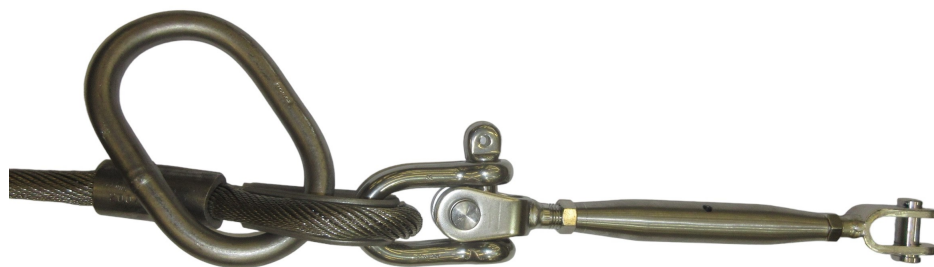

Fig. 31: Shackle/turnbuckle

28. Tighten the turnbuckle until the cable bundle is tight but does not lift the pump set off its seat.
29. Secure the turnbuckle against loosening with two locknuts.
30. Unclip the crane hook of the lifting equipment from the lifting lug. Free the power cables from the manila rope and route them to the control cabinet.
31. Tie the upper loosely suspended lifting lug to the cable bundle.
32. Remove the safety cover from the discharge tube. Fit the cover. Seal the cable entries if any.

5.4 Electrical system

5.4.1 Information for planning the control system

For the electrical connection of the pump set observe the "Wiring diagrams" section. (⇒ Section 9.4, Page 117)

The pump set is supplied with power cables; it is wired for DOL starting. Star-delta starting is possible.

	NOTE
	<p>When laying a cable between the control system and the pump set's connection point, verify that the number of cores is sufficient for the sensors. A minimum cross-section of 1.5 mm² is required.</p> <p>A pump set with sensor package Premium requires the electric cable from the intermediate terminal box to the control system to be designed with 4 wires of 1.5 mm² and shielded.</p> <p>When planning the control system for a pump set with sensor package Premium, the installation/operating manual of the AmaControl 5 sensor module is required.</p>

The motors can be connected to electrical low-voltage grids with mains voltages and voltage tolerances to IEC 60038. The permissible tolerances must be observed. (⇒ Section 6.2.1, Page 50)

5.4.1.1 Starting method

The pump set is wired for DOL starting. Star-delta starting is technically possible.

For reducing the starting current autotransformers or soft starters can be used. For selecting suitable devices observe the rated current of the motor.

At least three times the rated current is required for reliable start-up. The run-up time must not exceed 4 seconds.

After start-up of the pump, a soft starter must always be bypassed.

5.4.1.2 Setting the overload protection device

1. Protect the pump set against overloading by a thermal time-lag overload protection device in accordance with IEC 60947 and local regulations.
2. Set the overload protection device to the rated current specified on the name plate.

5.4.1.3 Level control

	 DANGER
	<p>Pump set running dry Explosion hazard!</p> <p>▷ Never allow an explosion-proof pump set to run dry!</p>

	CAUTION
	<p>Fluid level below the specified minimum Damage to the pump set by cavitation!</p> <p>▷ Never allow the fluid level to drop below the specified minimum.</p>

Automatic operation of the pump set in a sump / tank requires the use of level control equipment.
 Observe the minimum fluid level indicated. (⇒ Section 6.2.4.3, Page 51)

5.4.1.4 Operation on a frequency inverter

The pump set is driven by an induction machine to IEC 60034-12 designed for fixed speed operation. In accordance with IEC 60034-25, section 18, the pump set is suitable for operation on a frequency inverter.

	NOTE
	<p>For pump sets with rated voltages exceeding 500 V, a dv/dt filter should be fitted at the output of the frequency inverter to reduce the rate of voltage rise to the limits specified in IEC 60034-25, Section 18. Otherwise a considerably reduced service life of the insulation system has to be expected.</p>

	⚠ DANGER
	<p>Operation outside the permitted frequency range Explosion hazard!</p> <p>▷ Never operate an explosion-proof pump set outside the specified range.</p>

	⚠ DANGER
	<p>Incorrect selection and setting of the frequency inverter Explosion hazard!</p> <p>▷ Observe the following information on selecting and setting a frequency inverter.</p>

Selection When selecting a frequency inverter, check the following details:

- Data provided by the manufacturer
- Electrical data of the pump set, particularly the rated current
- Only voltage source inverters (VSI) with pulse width modulation (PWM) and carrier frequencies between 1 and 16 kHz are suitable.

Setting Observe the following instructions for setting a frequency inverter:

- Set the current limit to max. 1.2 times the rated current. The rated current is indicated on the name plate.

Start-up Observe the following instructions for starting the frequency inverter:

- Ensure short start ramps (maximum 5 seconds).
- Only start variable speed control after 2 minutes at the earliest.
 Pump start-up with long start ramps and low frequency may cause clogging.

Operation Observe the following limits during operation on a frequency inverter:

- Only utilise up to 95 % of the rated power P_2 indicated on the name plate.
- Frequency range 25 to 50 Hz

Electromagnetic compatibility Operation on a frequency inverter produces interference emissions whose level varies depending on the inverter used (type, interference suppression, make). To prevent the drive system, consisting of a submersible motor and a frequency inverter, from

exceeding any given limits always observe the EMC information provided by the inverter manufacturer. If the inverter manufacturer recommends a shielded power cable, make sure to use a submersible motor pump with shielded power cables.

Interference immunity The submersible motor pump generally meets interference immunity requirements. For monitoring the sensors installed the operator must ensure sufficient interference immunity by appropriately selecting and laying the power cables in the plant. No modifications are required on the power/control cable of the submersible motor pump. Suitable analysing devices must be selected. To monitor the leakage sensor inside the motor using a special relay available from KSB is recommended.

5.4.1.5 Sensors

5.4.1.5.1 Pump set with standard sensors

	<p>⚠ DANGER</p>
	<p>Operating an incompletely connected pump set Explosion hazard! Damage to the pump set!</p> <ul style="list-style-type: none"> ▶ Never start up a pump set with incompletely connected electric cables or non-operational monitoring devices.

	<p>CAUTION</p>
	<p>Incorrect wiring Damage to the sensors!</p> <ul style="list-style-type: none"> ▶ Observe the limits stated in the following sections of this manual when connecting the sensors.

The pump set features sensors designed to prevent hazards and damage to the pump set.

	<p>NOTE</p>
	<p>Reliable and safe operation of the pump within the scope of our warranty is only possible if the sensor signals are properly analysed as stipulated in this manual.</p>

All sensors are located inside the pump set and are connected to the sensor cable. For information on wiring and core marking see (⇒ Section 9.4, Page 117)
The individual sensors and the limit values to be set are described in the following sections.

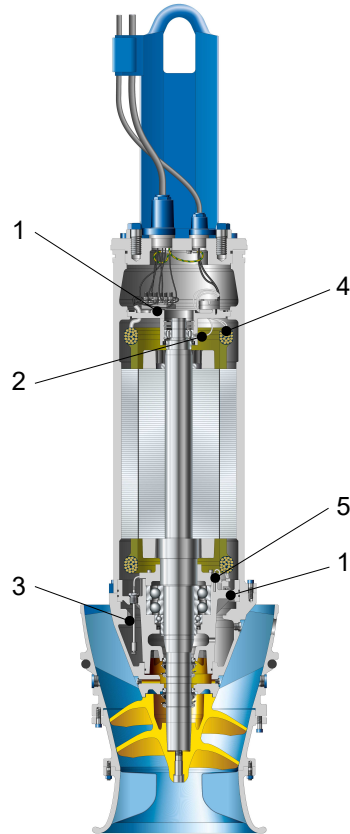





Fig. 32: Sensor positions

Table 9: Overview of sensors

Position	Sensor	Basic	Basic+
1	Leakage sensor in the motor space	X	X
2	Bearing temperature monitoring, motor end (Pt100)	-	X
3	Mechanical seal leakage sensor (float switch)	X	X
4	Motor temperature monitoring (PTC thermistor)	X	X
5	Bearing temperature monitoring, pump end (Pt100)	X	X

5.4.1.5.1.1 Motor temperature

 	 DANGER
	<p>Insufficient cooling Explosion hazard! Winding damage!</p> <ul style="list-style-type: none"> ▷ Never operate a pump set without operational temperature monitoring equipment. ▷ For explosion-proof pump sets use a thermistor motor protection relay with manual reset and ATEX certification for monitoring the temperature of explosion-proof motors in "flameproof enclosure" type of protection.

The motor is monitored by three series-connected PTC thermistors with terminals 10 and 11. Tripping must result in the pump set cutting out. Automatic re-starting is not permitted.

On explosion-proof pump sets, they must be connected to a thermistor motor

1581.85/01-EN

protection relay with manual reset and ATEX approval for monitoring the temperature of explosion-proof motors in "flameproof enclosure" type of protection.

5.4.1.5.1.2 Leakage inside the motor

	<p>⚠ DANGER</p>
	<p>Incorrect monitoring of leakage electrode Explosion hazard! Danger of death from electric shock!</p> <p>▷ Voltages must be < 30 V AC and tripping currents < 0.5 mA.</p>

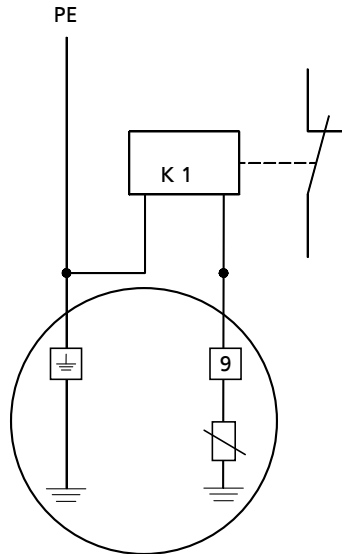

Fig. 33: Wiring of the electrode relay

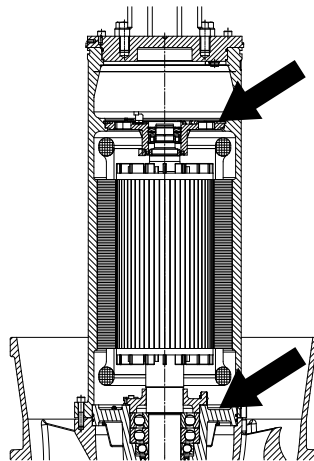

Fig. 34: Position of the electrodes in the motor housing

Electrodes fitted inside the motor monitor the winding and connection space for leakage. Both electrodes are connected in parallel (core identification 9). They must be connected to an electrode relay. Tripping of the electrode relay must result in the pump set cutting out.

The electrode relay (K1) must trip the motor at an electrical resistance between 3 and 60 kΩ.

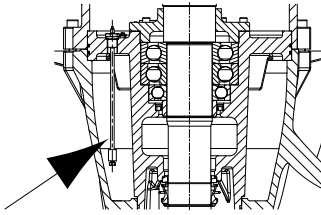

Fig. 35: Float switch

5.4.1.5.1.3 Mechanical seal leakage

The chamber for mechanical seal leakage is equipped with a float switch (core identification 3 and 4). The contact (maximum 250 V~/2 A) opens when leakage is detected in the leakage chamber. Opening of the contact shall trigger an alarm signal.

5.4.1.5.1.4 Bearing temperature

The pump-end bearing of the pump set is equipped with a bearing temperature sensor. This sensor is a Pt100 resistance thermometer (core identification 15 and 16). It must be connected to a temperature control device with a Pt100 input and two separate outputs for two different switching points (sensor circuit maximum 6 V / 2 mA).

Set the following limits:

- Alert at 110 °C
- Cut-out of the pump set at 130 °C

As an option, the motor-end bearing can also be equipped with a temperature sensor (core identification 16 and 17). Its connection and settings are identical with the above. Check in the data sheet whether the pump set is equipped with temperature monitoring of the motor-end bearing.

5.4.1.5.2 Pump set with sensor system

	<p style="background-color: #e67e22; color: white; padding: 5px;">⚠ DANGER</p> <p>Operating an incompletely connected pump set Explosion hazard! Damage to the pump set!</p> <ul style="list-style-type: none"> ▸ Never start up a pump set with incompletely connected electric cables or non-operational monitoring devices.
	<p style="background-color: #f1c40f; padding: 5px;">CAUTION</p> <p>Incorrect wiring Damage to the sensors!</p> <ul style="list-style-type: none"> ▸ Observe the limits stated in the following sections of this manual when connecting the sensors.

The pump set features sensors designed to prevent hazards and damage to the pump set.

All sensors are located inside the submersible motor pump and are connected to the sensor module located in the connection space of the submersible motor.

Sensor signals are analysed via the AmaControl 5 monitoring system.

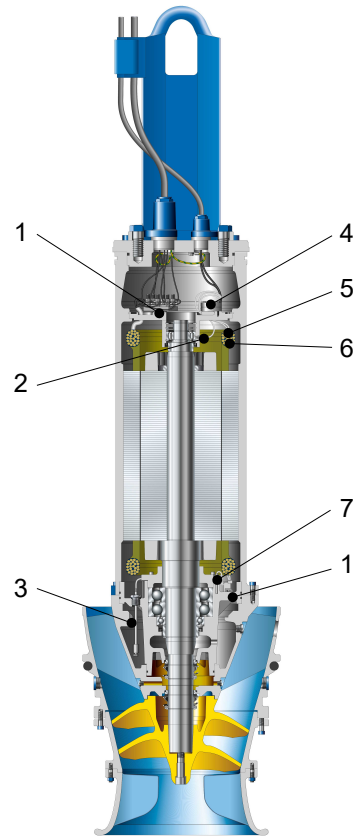

Fig. 36: Sensor positions

Table 10: Overview of sensors



Position	Sensor	Premium
1	Leakage sensor in the motor space	X
2	Bearing temperature monitoring, motor end (Pt100)	X
3	Mechanical seal leakage sensor (float switch)	X
4	Vibration monitoring	X
5	Motor temperature monitoring (PTC thermistor)	X
6	Motor temperature measurement (Pt100)	X
7	Bearing temperature monitoring, pump end (Pt100)	X

	NOTE
	Reliable and safe operation of the pump within the scope of our warranty is only possible if the sensor signals are properly analysed as stipulated in this manual.

For the electrical connection of the monitoring system observe the wiring diagram and the installation/operating manual of the associated AmaControl 5 monitoring system.

5.4.2 Electrical connection





	⚠ DANGER
	<p>Electrical connection work by unqualified personnel Danger of death from electric shock and explosion!</p> <ul style="list-style-type: none"> ▷ Always have the electrical connections installed by an electrically qualified person. ▷ Observe regulations IEC 60364 and, for explosion-proof versions, EN 60079 .

	<p>⚠ WARNING</p> <p>Incorrect connection to the mains Damage to the power supply network, short circuit!</p> <ul style="list-style-type: none"> ▷ Observe the technical specifications of the local energy supply companies.
	<p>CAUTION</p> <p>Improper routing of electric cables Damage to the electric cables!</p> <ul style="list-style-type: none"> ▷ Never move the electric cables at temperatures below -25 °C. ▷ Never kink or crush the electric cables. ▷ Never lift the pump set by the electric cables. ▷ Adjust the length of the electric cables to the site requirements.
	<p>CAUTION</p> <p>Motor overload Damage to the motor!</p> <ul style="list-style-type: none"> ▷ Protect the motor by a thermal time-lag overload protection device in accordance with IEC 60947 and local regulations.

For the electrical connection observe the wiring diagrams (⇒ Section 9.4, Page 117) in the Annex and the information for planning the control system .

The pump set is supplied with power cables.

Always use all electric cables provided and connect all marked cores of the sensor cable.

	<p>⚠ DANGER</p> <p>Incorrect wiring Explosion hazard!</p> <ul style="list-style-type: none"> ▷ The connection point of the cable ends must be located outside of the potentially explosive atmosphere or inside electrical equipment approved to equipment category II2G.
 	<p>⚠ DANGER</p> <p>Operating an incompletely connected pump set Explosion hazard! Damage to the pump set!</p> <ul style="list-style-type: none"> ▷ Never start up a pump set with incompletely connected electric cables or non-operational monitoring devices.
	<p>⚠ DANGER</p> <p>Connection of damaged electric cables Danger of death from electric shock!</p> <ul style="list-style-type: none"> ▷ Check the electric cables for any damage before connecting them. ▷ Never connect damaged electric cables. ▷ Replace damaged electric cables.

	CAUTION
	<p>Flow-induced motion Damage to the power cable!</p> <p>▷ Run the power cable upwards without slack.</p>

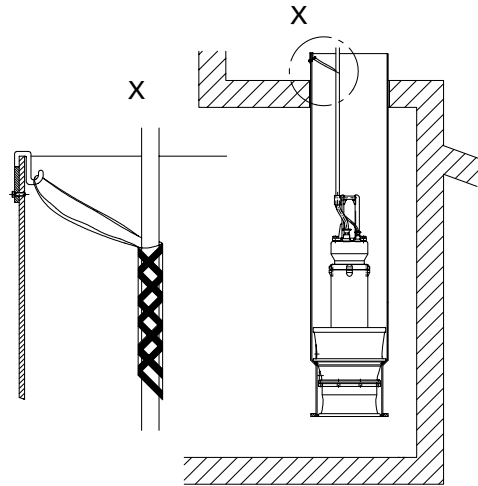





Fig. 37: Fastening the power cable

1. Run the power cables upwards without slack and fasten them.
2. Only remove the protective caps from the power cables immediately before connecting the cables.
3. If necessary, adjust the length of the power cables to the site requirements.
4. After shortening the cable, correctly re-affix the markings on the individual cores at the cable ends.

Potential equalisation The pump set is not fitted with an external potential equalisation connection (risk of corrosion).







	 DANGER
	<p>Incorrect wiring Explosion hazard!</p> <p>▷ Explosion-proof pump sets installed in a tank must never be retrofitted with an external potential equalisation connection!</p>

	 DANGER
	<p>Touching the pump set during operation Electric shock!</p> <p>▷ Make sure that the pump set cannot be touched during operation.</p>

6 Commissioning/Start-up/Shutdown

6.1 Commissioning/Start-up

6.1.1 Prerequisites for commissioning/start-up

	 DANGER
	<p>Operating the pump set without protective equipment Electric shock! Risk of injury! Danger of death from drowning!</p> <ul style="list-style-type: none"> ▷ Never start up the pump set without special protective equipment when there are persons in the tank. ▷ If persons come into contact with the fluid handled during pump operation (e.g. in sports facilities and leisure parks), the plant designer/operator must comply with the legal requirements. ▷ Provide special electrical and mechanical protective equipment compliant with the legal regulations.
	 WARNING
	<p>Operating the pump set without mechanical protective equipment Risk of injury from solid matter in the fluid handled!</p> <ul style="list-style-type: none"> ▷ If persons come into contact with the fluid handled during pump operation (e.g. in sports facilities and leisure parks), install mechanical protective equipment (e.g. a screen) on the discharge side of the pump set.
	 WARNING
	<p>People falling into the unsecured discharge tube Risk of personal injury!</p> <ul style="list-style-type: none"> ▷ Take suitable precautions during the entire installation/removal process to protect people from falling into the open discharge tube. ▷ Fence off the work area appropriately.

Before commissioning/starting up the pump set, make sure that the following conditions are met:

- The lubricant has been checked.
- The direction of rotation has been checked.
- The pump set has been properly connected to the power supply and is equipped with all protection devices.
- The pump set has been installed in the discharge tube as described in this manual.
- The minimum fluid level has been reached.
- After prolonged shutdown of the pump (set), the activities required for returning the equipment to service have been carried out. (⇒ Section 6.4, Page 53)
- Safety-relevant protective equipment must be installed and fully functional.

6.1.2 Start-up

	DANGER
	<p>Operating the pump set without protective equipment Electric shock! Risk of injury! Danger of death from drowning!</p> <ul style="list-style-type: none"> ▷ Never start up the pump set without special protective equipment when there are persons in the tank. ▷ If persons come into contact with the fluid handled during pump operation (e.g. in sports facilities and leisure parks), the plant designer/operator must comply with the legal requirements. ▷ Provide special electrical and mechanical protective equipment compliant with the legal regulations.

	CAUTION
	<p>Re-starting while motor is still running down Damage to the pump set!</p> <ul style="list-style-type: none"> ▷ Do not re-start the pump set before it has come to a standstill. ▷ Never start up the pump set while the pump is running in reverse.

✓ The fluid level is sufficiently high.

	CAUTION
	<p>Start-up against a closed shut-off element Damage to the pump set!</p> <ul style="list-style-type: none"> ▷ Never operate the pump set against a closed shut-off element.

1. Fully open the discharge line shut-off element, if any.
2. Start up the pump set.

6.2 Operating limits

	DANGER
	<p>Non-compliance with operating limits Damage to the pump set! Explosion hazard!</p> <ul style="list-style-type: none"> ▷ Comply with the operating data specified in the data sheet. ▷ Avoid operation below Q_{min}. ▷ Never operate an explosion-proof pump set at ambient temperatures or fluid temperatures exceeding those specified in the data sheet and/or on the name plate. ▷ Never operate the pump set outside the limits specified below.

6.2.1 Operation on the power supply mains

 	<p>⚠ DANGER</p>
	<p>Permissible tolerances for operation on mains power exceeded Explosion hazard!</p> <ul style="list-style-type: none"> ▶ Never operate an explosion-proof pump (set) outside the specified range.

The mains voltage and mains frequency may fluctuate around the rated values as defined for zone B to IEC 60034-1. The voltage difference between the individual phases must not exceed 1 %.

6.2.2 Frequency of starts

	<p>CAUTION</p>
	<p>Excessive frequency of starts Risk of damage to the motor!</p> <ul style="list-style-type: none"> ▶ Never exceed the specified frequency of starts.

To prevent high temperature increases in the motor and excessive loads on the motor, seal elements and bearings, the frequency of starts shall not exceed 10 starts per hour.

These values apply to mains start-up (DOL or with star-delta contactor, autotransformer, soft starter). This limitation does not apply to operation on a frequency inverter.

	<p>CAUTION</p>
	<p>Re-starting while motor is still running down Damage to the pump set!</p> <ul style="list-style-type: none"> ▶ Do not re-start the pump set before it has come to a standstill. ▶ Never start up the pump set while the pump is running in reverse.

6.2.3 Operation on a frequency inverter

	<p>⚠ DANGER</p>
	<p>Operation outside the permitted frequency range Explosion hazard!</p> <ul style="list-style-type: none"> ▶ Never operate an explosion-proof pump set outside the specified range.

	<p>CAUTION</p>
	<p>Pumping solids-laden fluids at reduced speed Increased wear and clogging!</p> <ul style="list-style-type: none"> ▶ Never operate the pump set with flow velocities below 0.7 m/s in horizontal pipes and 1.2 m/s in vertical pipes.

Frequency inverter operation of the pump set is permitted in the frequency range from 25 to 50 Hz.

6.2.4 Fluid handled

6.2.4.1 Fluid temperature

The pump set is designed for transporting liquids. The pump set is not operational under freezing conditions.

	CAUTION
	<p>Danger of freezing! Damage to the pump set!</p> <ul style="list-style-type: none"> ▷ Drain the pump set or protect it against freezing.

Refer to the maximum permissible fluid temperature and ambient temperature indicated on the name plate and/or in the data sheet.

6.2.4.2 Density of the fluid handled

The power input of the pump set will change in proportion to the density of the fluid handled.

	CAUTION
	<p>Impermissibly high density of the fluid handled Motor overload!</p> <ul style="list-style-type: none"> ▷ Observe the information about fluid density in the data sheet. ▷ Make sure the motor has sufficient power reserves.

6.2.4.3 Minimum level of fluid handled

	⚠ DANGER
	<p>Pump set running dry Explosion hazard!</p> <ul style="list-style-type: none"> ▷ Never allow an explosion-proof pump set to run dry!

	CAUTION
	<p>Fluid level below the specified minimum Damage to the pump set by cavitation and air-entraining vortices!</p> <ul style="list-style-type: none"> ▷ Never allow the fluid level to drop below the specified minimum.

The pump set is ready for operation when the fluid level has reached dimension "t₁" as a minimum (see general arrangement drawing/outline drawing).

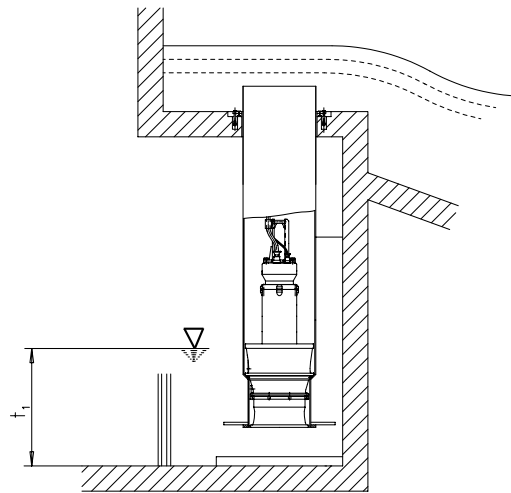

Fig. 38: Example: Minimum level of fluid handled

6.2.4.4 Abrasive fluids

Do not exceed the maximum permissible solids content specified in the data sheet. When the pump handles fluids containing abrasive substances, increased wear of the hydraulic system and shaft seal are to be expected. In this case, reduce the commonly recommended inspection intervals.

6.3 Shutdown/storage/preservation

6.3.1 Shutdown

	CAUTION
	<p>Uncontrolled backflow of the fluid from the riser Damage to the pump set!</p> <ul style="list-style-type: none"> ▷ Prevent any uncontrolled backflow of the fluid handled with suitable means. ▷ Control the fluid backflow, e.g. by throttling the gate valve in the discharge line.

6.3.2 Measures to be taken for shutdown

	⚠ DANGER
	<p>Electrical connection work by unqualified personnel Danger to life from electric shock</p> <ul style="list-style-type: none"> ▷ Always have the electrical connections installed by an electrically qualified person. ▷ Observe the IEC 60364 regulations as well as any regional regulations.

	⚠ WARNING
	<p>Unintentional starting of the pump set Risk of injury by moving components and shock currents!</p> <ul style="list-style-type: none"> ▷ Ensure that the pump set cannot be started unintentionally. ▷ Always make sure the electrical connections are disconnected before carrying out work on the pump set.

1581.85/01-EN

	<p>! WARNING</p>
	<p>Fluids handled, consumables and supplies which are hot and/or pose a health hazard</p> <p>Risk of injury!</p> <ul style="list-style-type: none"> ▷ Observe all relevant laws. ▷ When draining the fluid take appropriate measures to protect persons and the environment. ▷ Decontaminate pumps which handle fluids posing a health hazard.
	<p>CAUTION</p>
	<p>Danger of frost/freezing</p> <p>Damage to the pump set!</p> <ul style="list-style-type: none"> ▷ If there is any danger of frost/freezing, remove the pump set from the fluid handled and clean, preserve and store it.

The pump set remains installed

- ✓ Make sure sufficient fluid is available for the functional check run of the pump set.
1. For prolonged shutdown periods, start up the pump set regularly once every three months for approximately one minute.
This will prevent the formation of deposits within the pump and the pump intake area.

The pump (set) is removed from the pipe and stored.

- ✓ All safety regulations are observed.
1. Clean the pump set.
 2. Preserve the pump set.

6.4 Returning to service

For returning the pump set to service, observe the instructions on commissioning/start-up. (⇒ Section 6.1, Page 48)

Refer to and comply with the operating limits.





For returning the pump set to service after storage also follow the instructions for maintenance/inspection.







	<p>! WARNING</p>
	<p>Failure to re-install or re-activate protective devices</p> <p>Risk of injury from moving parts or escaping fluid!</p> <ul style="list-style-type: none"> ▷ As soon as the work is completed, properly re-install and re-activate any safety-relevant devices and protective devices.
	<p>NOTE</p>
	<p>On pumps/pump sets older than 5 years we recommend replacing all elastomer seals.</p>

7 Servicing/Maintenance

7.1 Safety regulations

The operator ensures that maintenance, inspection and installation are performed by authorised, qualified specialist personnel who are thoroughly familiar with the manual.

	<p>⚠ DANGER</p> <p>Sparks produced during servicing work Explosion hazard!</p> <ul style="list-style-type: none"> ▷ Observe the safety regulations in force at the place of installation! ▷ Never open an energised pump set. ▷ Always perform maintenance work on explosion-proof pump sets outside potentially explosive atmospheres only.
	<p>⚠ DANGER</p> <p>Improperly serviced pump set Explosion hazard! Damage to the pump set!</p> <ul style="list-style-type: none"> ▷ Service the pump set regularly. ▷ Prepare a maintenance schedule with special emphasis on lubricants, electric cables, bearing assembly and shaft seal.
	<p>⚠ DANGER</p> <p>Improper lifting/moving of heavy assemblies or components Danger to life from falling parts! Damage to the pump set!</p> <ul style="list-style-type: none"> ▷ Use suitable transport equipment, lifting equipment and lifting tackle to move heavy assemblies or components. ▷ Use the attachment point provided for attaching the lifting accessory. ▷ Never lift the pump set by the electric cables. ▷ Use the lifting chain/rope included in the scope of supply exclusively for lowering or lifting the pump set into/out of the pump sump. ▷ Securely attach the lifting chain/rope to the pump and crane. ▷ Use tested, marked and approved lifting accessories only. ▷ Observe the regional transport regulations. ▷ Observe the documentation of the lifting accessory manufacturer. ▷ The load-carrying capacity of the lifting accessory must be higher than the weight indicated on the name plate of the pump set to be lifted. Take into account any additional system components to be lifted. ▷ Maintain a safe distance during lifting operations (load may swing when being lifted).
	<p>⚠ DANGER</p> <p>Electrical connection work by unqualified personnel Danger to life from electric shock</p> <ul style="list-style-type: none"> ▷ Always have the electrical connections installed by an electrically qualified person. ▷ Observe the IEC 60364 regulations as well as any regional regulations.

	<p>⚠ DANGER</p> <p>Risk of falling when working at a great height Danger to life by falling from a great height!</p> <ul style="list-style-type: none"> ▷ Do not step onto the pump (set) during installation work or dismantling work. ▷ Pay attention to safety equipment, such as railings, covers, barriers, etc. ▷ Observe the applicable local health and occupational safety regulations and accident prevention regulations.
	<p>⚠ WARNING</p> <p>Unintentional starting of the pump set Risk of injury by moving components and shock currents!</p> <ul style="list-style-type: none"> ▷ Ensure that the pump set cannot be started unintentionally. ▷ Always make sure the electrical connections are disconnected before carrying out work on the pump set.
	<p>⚠ WARNING</p> <p>Hands, other body parts or foreign objects in the impeller or intake area Risk of injury! Damage to the submersible motor pump!</p> <ul style="list-style-type: none"> ▷ Never insert your hands, other body parts or foreign objects into the impeller or impeller intake area. ▷ Always make sure the electrical connections are disconnected before checking whether the impeller rotates freely.
	<p>⚠ WARNING</p> <p>Fluids handled, consumables and supplies which are hot and/or pose a health hazard Risk of injury!</p> <ul style="list-style-type: none"> ▷ Observe all relevant laws. ▷ When draining the fluid take appropriate measures to protect persons and the environment. ▷ Decontaminate pumps which handle fluids posing a health hazard.
	<p>⚠ WARNING</p> <p>Hot surface Risk of injury!</p> <ul style="list-style-type: none"> ▷ Allow the pump set to cool down to ambient temperature.
	<p>⚠ WARNING</p> <p>Improper lifting/moving of heavy assemblies or components Personal injury and damage to property!</p> <ul style="list-style-type: none"> ▷ Use suitable transport devices, lifting equipment and lifting tackle to move heavy assemblies or components.

	⚠ WARNING
	Insufficient stability Risk of crushing hands and feet! ▷ During assembly/dismantling, secure the pump (set)/pump parts to prevent tilting or tipping over.

	⚠ WARNING
	Corrosion on the pump set Risk of injury from solid matter in the fluid handled! ▷ If persons come into contact with the fluid handled during pump operation (e.g. in sports facilities and leisure parks), check the pump set for corrosion regularly and adhere to the maintenance interval specified.

	NOTE
	Special regulations apply to repair work on explosion-proof pump sets. Modification or alteration of the pump set may affect explosion protection and are only permitted after consultation with the manufacturer.

A regular maintenance schedule will help avoid expensive repairs and contribute to trouble-free, reliable operation of the pump, pump set and pump parts with a minimum of servicing/maintenance expenditure and work.

	NOTE
	All maintenance work, service work and installation work can be carried out by KSB Service or authorised workshops. Find your contact in the attached Addresses booklet or visit https://www.ksb.com/en-global/contact .

Never use force when dismantling and reassembling the pump set.

7.2 Maintenance/inspection

KSB recommends the following regular maintenance schedule:

Table 11: Overview of maintenance work

Maintenance interval	Maintenance work	For details see ...
<ul style="list-style-type: none"> ▪ First check after 6 months min. ▪ Interval can be extended to 12 months 	If used in sports facilities and leisure parks, check visually for corrosion.	(⇒ Section 7.3.7, Page 63)
	For a pump set in material variant G3 perform the first check after 6 months. If the sacrificial anodes show little wear, the maintenance interval can be extended to 12 months.	(⇒ Section 7.8, Page 90)
<ul style="list-style-type: none"> ▪ Every 4000 h ▪ At least once a year 	Check the insulation resistance.	
	<ul style="list-style-type: none"> ▪ Every 8000 h ▪ At least every 3 years 	Check the cable bundle.
Check the lifting accessories.		
Check the earth conductor.		
Check the sensors.		(⇒ Section 7.2.1.2.1, Page 57) (⇒ Section 7.2.1.2.2, Page 58)
Check the mechanical seal leakage.		(⇒ Section 7.3.6, Page 62)
<ul style="list-style-type: none"> ▪ Every 24,000 h ▪ At least every 5 years 	Change the lubricant.	(⇒ Section 7.4.1.4, Page 64)
	Lubricate and replace the rolling element bearings.	(⇒ Section 7.4.2, Page 66)

Maintenance interval	Maintenance work	For details see ...
<ul style="list-style-type: none"> ▪ Every 24,000 h ▪ At least every 5 years 	For a pump set in material variant G3 replace the sacrificial anode if this has not already been done as part of a previous inspection. General overhaul	(⇒ Section 7.8, Page 90)

7.2.1 Inspection work

7.2.1.1 Measuring the insulation resistance

Measure the insulation resistance of the motor winding during annual maintenance work.

- ✓ The pump set has been disconnected in the control cabinet.
 - ✓ Use an insulation resistance measuring device.
 - ✓ The recommended measuring voltage is 500 V (maximum permissible voltage: 1000 V).
 1. Measure the winding to chassis ground.
To do so, connect all winding ends together.
- ⇒ The insulation resistance of the core ends to chassis ground must not be lower than 1 MΩ.
If the resistance measured is lower, power cable and motor resistance must be measured separately. Disconnect the power cable from the motor for this purpose.

	NOTE
	If the insulation resistance of the power cable is lower than 1 MΩ, the power cable is defective and must be replaced.

	NOTE
	If the insulation resistances measured on the motor are too low, the winding insulation is defective. The pump set must not be returned to service in this case.

7.2.1.2 Checking the sensors

7.2.1.2.1 Checking the sensors, pump set with standard sensors

	CAUTION
	Excessive test voltage Damage to the sensors! ▶ Use a commercially available ohmmeter to measure the resistance.

The tests described below measure the resistance at the core ends of the control cable. The actual sensor function is not tested.

Temperature sensors in the motor winding

Table 12: Resistance measurement

Measurement between terminals ...	Resistance
	[Ω]
10 and 11	200 - 1000
31 and 32 ⁷⁾	100 - 120
33 and 34 ⁷⁾	100 - 120
35 and 36 ⁷⁾	100 - 120

⁷⁾ Optional

If the specified tolerances are exceeded, disconnect the power cable at the pump set and repeat the check inside the motor.
 If the tolerances are exceeded here, too, the motor section has to be opened and overhauled. The temperature sensors are fitted in the stator winding and cannot be replaced.

If the sensors are defective, use the back-up sensors provided at the same place in the stator winding.

Leakage sensor in the motor

Table 13: Resistance measurement of the leakage sensor in the motor

Measurement between terminals ...	Resistance
	[kΩ]
9 and earth conductor (PE)	> 60

Lower resistance values suggest water ingress into the motor. In this case the motor section must be opened and serviced.

Float switch (mechanical seal leakage)

Table 14: Resistance measurement of the float switch

Measurement between terminals ...	Resistance
	[Ω]
3 and 4	< 1

If the readings suggest an open switch, check for mechanical seal leakage.

Bearing temperature sensor

Table 15: Resistance measurement of the bearing temperature sensors

Measurement between terminals ...	Resistance
	[Ω]
15 and 16	100 to 120
16 and 17 ⁸⁾	100 to 120

7.2.1.2.2 Checking the sensors, pump set with sensor system

	CAUTION
	<p>Excessive test voltage Damage to the sensors!</p> <p>▷ Use a commercially available ohmmeter to measure the resistance.</p>

The tests described below measure the resistance. The actual function of the sensors is not tested.

The regular maintenance schedule includes checking the resistance values on the display of AmaControl 5. Direct measurement from the outside is not possible.

If the following limits are exceeded, the submersible motor pump has to be removed.

1. To clarify a potential sensor error, open the connection space of the pump set. (⇒ Section 7.5.6.1, Page 74)
2. Disconnect the sensor in question from the integrated sensor module.
 ⇒ Only now can the electrical resistance be measured with an ohmmeter.

Temperature sensors in the motor winding

Table 16: Resistance measurement of the temperature sensors on the motor winding

Display at AmaControl	Check with ohmmeter	Resistance
Sensor	Measurement between cores	[Ω]
Motor temperature - PTC	10 and 11	100 to 1000
Temperature 3 - Pt100	31 and 32	100 to 120

The temperature sensors are fitted in the stator winding and cannot be replaced.

⁸ Included in the standard design for size 1600-1060; for other sizes optional

If the sensors are defective, use the back-up sensors provided at the same place in the stator winding.

Bearing temperature sensor Table 17: Resistance measurement – bearing temperature sensor

Display at AmaControl	Check with ohmmeter	Resistance
Sensor	Measurement between cores	[Ω]
Temperature 1 - Pt100	15 and 16	100 to 120
Temperature 2 - Pt100	17 and 18	100 to 120

If the tolerances indicated are exceeded, replace bearing temperature sensor.

Leakage sensor in the motor Table 18: Resistance measurement of the leakage sensor in the motor

Display at AmaControl	Check with ohmmeter	Resistance
Sensor	Measurement between cores	[kΩ]
Leakage 1	9 and earth conductor (PE)	> 60

Lower resistance values suggest water ingress into the motor. In this case, open and service the motor section.

Mechanical seal leakage sensor (float switch) Table 19: Resistance of leakage sensor at mechanical seal (float switch)

Display at AmaControl	Check with ohmmeter	Resistance
Sensor	Measurement between cores	[Ω]
Leakage 3 - float switch	3 and 4	< 1

Lower values indicate water ingress into the lubricant chamber. In this case, check the pump-end mechanical seal.

7.3 Removing the pump set

7.3.1 Removing the pump set

	⚠ DANGER
	<p>Insufficient preparation of work on the pump (set) Risk of injury!</p> <ul style="list-style-type: none"> ▷ Properly shut down the pump set. ▷ Close the shut-off elements in the suction line and discharge line. ▷ Drain the pump and release the pump pressure. ▷ Shut off any auxiliary feed lines. ▷ Allow the pump set to cool down to ambient temperature.
	⚠ WARNING
	<p>Incorrect handling of the electric cable Personal injury and damage to property!</p> <ul style="list-style-type: none"> ▷ Secure electric cables against falling down. ▷ Avoid electric cables being laid on surfaces without fastening. ▷ When moving the pump set keep at a safe distance to the electric cables.

	! WARNING
	<p>People falling into the unsecured discharge tube Risk of personal injury!</p> <ul style="list-style-type: none"> ▷ Take suitable precautions during the entire installation/removal process to protect people from falling into the open discharge tube. ▷ Fence off the work area appropriately.

	! WARNING
	<p>Turnbuckle and shackle are not suitable for lifting the pump set Risk of injury! Damage to the pump set!</p> <ul style="list-style-type: none"> ▷ Always use the lifting lugs of the support rope to lift the pump set.

- ✓ The power cables have been disconnected and secured against unintentional start-up.
- ✓ The discharge tube is open; its opening is securely covered except for a gap allowing work to continue.
- ✓ Suitable lifting equipment is provided.
 1. Attach the lifting chain or lifting rope to the trolley.
 2. Free the uppermost lifting lug from the cables, attach it to the crane hook and run the lifting equipment to a higher level.
 3. Open and disconnect the turnbuckle.

	NOTE
	<p>Prevent any loose parts from falling into the pump sump!</p>

4. Pull the pump set up until it reaches the second lifting lug of the cable bundle.
5. Attach the lifting chain or lifting rope with the shackle to the first lifting lug (together with the crane hook).
6. Unclip the crane hook and attach it to the second lifting lug.
7. Pull the pump set up until it reaches the third lifting lug. Free the lifting chain or lifting rope from the first lifting lug and attach it to the third lifting lug.
8. Pull the pump set up until it reaches the fourth lifting lug. Unclip the crane hook and attach it to the fourth lifting lug.
9. Repeat this procedure until the pump bail is located above the discharge tube, then attach it to the crane hook.
10. Remove the safety cover from the discharge tube.
11. Extract the pump set from the discharge tube, move it sideways and place it down.

	! WARNING
	<p>Pump set tilting Risk of squashing hands and feet!</p> <ul style="list-style-type: none"> ▷ Suspend or support the pump set.

	CAUTION
	<p>Improper storage Damage to the power cables!</p> <ul style="list-style-type: none"> ▷ Support the power cables at the cable entry to prevent permanent deformation. ▷ Protect the core ends against moisture.

12. To prevent the pump set from tipping over, do not disconnect it from the hook of the lifting equipment.
13. Clean the pump set (e.g. with water).
14. Collect and properly dispose of any cleaning liquid.

7.3.2 Drainage/cleaning

	! WARNING
	<p>Fluids handled, consumables and supplies which are hot and/or pose a health hazard Hazard to persons and the environment!</p> <ul style="list-style-type: none"> ▷ Collect and properly dispose of flushing fluid and any fluid residues. ▷ Wear safety clothing and a protective mask if required. ▷ Observe all legal regulations on the disposal of fluids posing a health hazard.

1. Always flush the pump if it has been used for handling noxious, explosive, hot or other hazardous fluids.
2. Always flush and clean the pump before transporting it to the workshop. Provide a certificate of decontamination for the pump set. (⇒ Section 11, Page 150)

7.3.3 Checking the cable bundle

When removing the pump set from the discharge tube check the support rope and attachment (shackle) and all electric cables for any damage. In addition, observe the operating manual of the lifting accessories. Replace any damaged components by original spare parts.

Longer cable bundles must be dismantled:

1. Undo the cable clamps.
2. Remove the spacer.
3. Roll up the electric cables and place them next to the pump set.
4. Undo the shackle to separate the support rope from the pump set.

7.3.4 Checking the lifting accessories

- ✓ The pump set has been lifted out of the discharge tube and cleaned.
 1. Check the bail including fasteners (screws/bolts) for any visible damage.
 2. Replace any damaged components by original spare parts.

7.3.5 Checking the earth conductor

1. Measure the resistance between earth conductor and earth. The resistance must be below 1 Ω.
2. Replace any damaged components by original spare parts.

	<p>⚠ DANGER</p>
	<p>Defective earth conductor Electric shock!</p> <ul style="list-style-type: none"> ▷ Never switch on a pump set with a defective earth conductor.

7.3.6 Checking the mechanical seal leakage

	<p>⚠ WARNING</p>
	<p>Fluids handled, consumables and supplies which are hot and/or pose a health hazard Hazard to persons and the environment!</p> <ul style="list-style-type: none"> ▷ Collect and properly dispose of flushing fluid and any fluid residues. ▷ Wear safety clothing and a protective mask if required. ▷ Observe all legal regulations on the disposal of fluids posing a health hazard.

	<p>⚠ WARNING</p>
	<p>Excess pressure inside the pump set Risk of injury when opening the pump set!</p> <ul style="list-style-type: none"> ▷ Take care when opening the inner chambers. Equalise the pressure.

	<p>NOTE</p>
	<p>Slight wear of the mechanical seal is unavoidable. This will be aggravated by abrasive substances contained in the fluid handled.</p>

Checking the leakage chamber serves to assess the function of the drive-end mechanical seal.

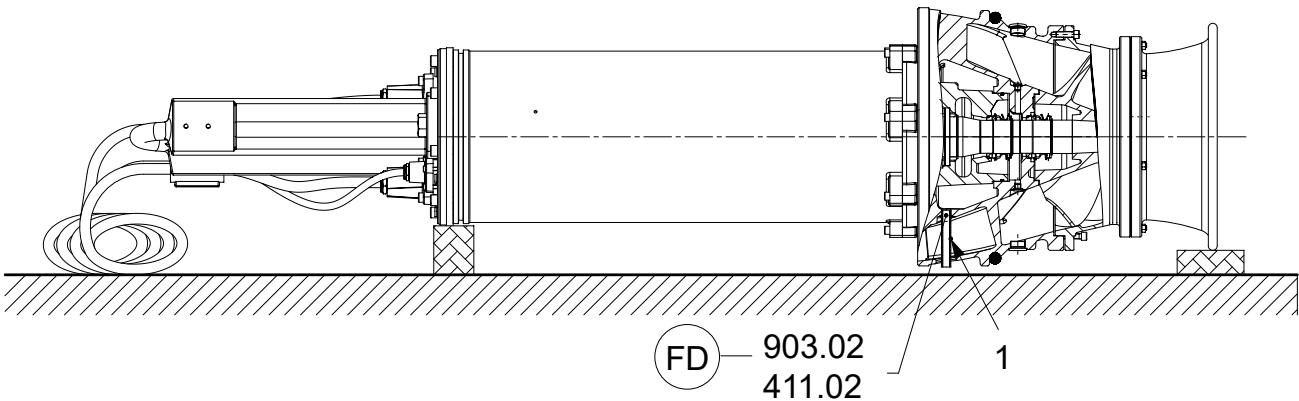



Fig. 39: Checking the leakage chamber

Table 20: Symbols key

Symbol	Description
	Always apply a liquid sealant (e.g. Hylomar SQ32M) to sealing surfaces marked with this symbol.

- ✓ A suitable container for the leakage is available.
 - ✓ The pump set is positioned horizontally on a level surface and is protected against rolling away.
1. Place the container underneath screw plug 903.02.
 2. Remove screw plug 903.02 with joint ring 411.02.
 3. Screw in a sufficiently long tube (1) with G 1/2 thread.



4. Carefully rotate the pump set until the opening of the leakage chamber points downwards.
 - ⇒ If there is no leakage or, after several years of operation, only a small amount, the mechanical seals are working properly. If the leakage exceeds 1 litre, the mechanical seals are defective and must be replaced.
5. Unscrew and remove the tube (1).
6. Re-insert and tighten screw plug 903.02 with new joint ring 411.02.

7.3.7 Visually inspecting for corrosion

- ✓ The pump set has been removed from the system.
 1. Conduct a visual inspection of the pump set.
 - ⇒ Clearly visible corrosion: Replace defective components and check corrosion protection.
 - ⇒ No visible corrosion: Extend visual inspection interval to 12 months.

7.4 Lubrication and lubricant change

7.4.1 Lubricating the mechanical seal

	 DANGER	
	<p>Excessive temperatures at the shaft seal Explosion hazard! Damage to the pump set!</p> <ul style="list-style-type: none"> ▷ Regularly check the condition of the lubricant in the lubricant reservoir of the mechanical seal. Top it up if required. 	

The mechanical seal is supplied with lubricating liquid from the lubricant reservoir.

7.4.1.1 Intervals

Replace the lubricant every 8000 operating hours but at least every 3 years.

7.4.1.2 Lubricant quality



The lubricant reservoir is filled at the factory with environmentally friendly, non-toxic lubricant of medicinal quality (unless otherwise specified by the customer). The following lubricants can be used to lubricate the mechanical seals:

Recommended lubricant quality
Alternative

- Environmentally friendly, non-toxic white oil of medical quality
- Thin-bodied paraffin oil, non-toxic
- Water/propylene glycol mixture with corrosion inhibitors for frost protection down to -20 °C

Table 21: Lubricant quality

Description	Properties	
Paraffin oil or white oil	Kinematic viscosity at 40 °C	< 20 mm ² /s
	Flash point (to Cleveland)	> 160 °C
	Solidification point (pour point)	< -15 °C

	 WARNING	
	<p>Lubricant contaminating fluid handled Hazard to persons and the environment!</p> <ul style="list-style-type: none"> ▷ Using machine oil is only permitted if the oil is disposed of properly. 	

7.4.1.3 Lubricant quantity

Table 22: Lubricant quantity

Pump size	Motor size	Lubricant quantity
		[l]
600 - 390	70 4 ... 130 4	1,5
	47 6 ... 80 6	1,5
600 - 420	70 4 ... 130 4	1,5
700 - 460	90 4 ... 130 4	1,4
	47 6 ... 120 6	1,4
	150 4 ... 215 4	2,2
	155 6	2,2
800 - 460	275 4 ... 300 4	2,2
800 - 580	80 6 ... 120 6	1,4
	155 6 ... 340 6	2,2
900 - 630	155 6 ... 205 6	3,6
	250 6 ... 340 6	3,3
900 - 650	155 6 ... 205 6	3,6
	250 6 ... 340 6	3,3

7.4.1.4 Changing the lubricant

	<p>⚠ WARNING</p> <p>Lubricants posing a health hazard and/or hot lubricants Hazard to persons and the environment!</p> <ul style="list-style-type: none"> ▶ When draining the lubricant take appropriate measures to protect persons and the environment. ▶ Wear safety clothing and a protective mask if required. ▶ Collect and dispose of any lubricants. ▶ Observe all legal regulations on the disposal of fluids posing a health hazard.
	<p>⚠ WARNING</p> <p>Excess pressure inside the pump set Risk of injury when opening the pump set!</p> <ul style="list-style-type: none"> ▶ Take care when opening the inner chambers. Equalise the pressure.
	<p>⚠ WARNING</p> <p>Improper handling when placing the pump set in a vertical/horizontal position Personal injury and damage to property!</p> <ul style="list-style-type: none"> ▶ Select suitable lifting equipment for the size of the pump. ▶ Use appropriate means to secure the pump set against tilting, tipping over or rolling off. ▶ Maintain a safe distance during lifting operations (load may swing when being lifted). ▶ Use additional supports for the transport holder to secure it against tilting.

7.4.1.4.1 Draining the lubricant

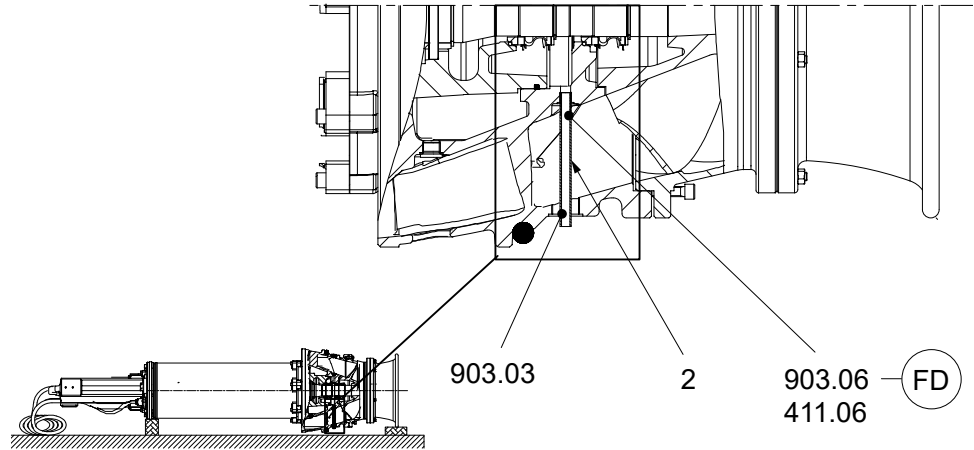



Fig. 40: Draining the lubricant

Table 23: Symbols key

Symbol	Description
	Always apply a liquid sealant (e.g. Hylomar SQ32M) to sealing surfaces marked with this symbol.

1. Place the pump set down in a horizontal position. Secure it against rolling away.
2. Remove screw plug 903.03.
 - ⇒ Screw plug 903.03 is marked with label/plate 970.03 (oil drain).
3. Remove screw plug 903.06 and joint ring 411.06.
4. Screw in a sufficiently long tube (2) with G 1/4 thread.
5. Carefully rotate the pump set until the tube points downwards.

	NOTE
	Undoing screw plug 903.01 will make the lubricant drain faster.

6. Collect the lubricant in a suitable container. Determine the quantity of lubricant collected and compare it with the specified lubricant quantity .
 - ⇒ If more than 1 litre of lubricant is required for topping up, this suggests a defect of the mechanical seal.
7. Properly dispose of the lubricant.
8. Remove the tube. Close screw plug 903.06 with joint ring 411.06 again.
9. Re-insert and tighten screw plug 903.03.

7.4.1.4.2 Filling in the lubricant

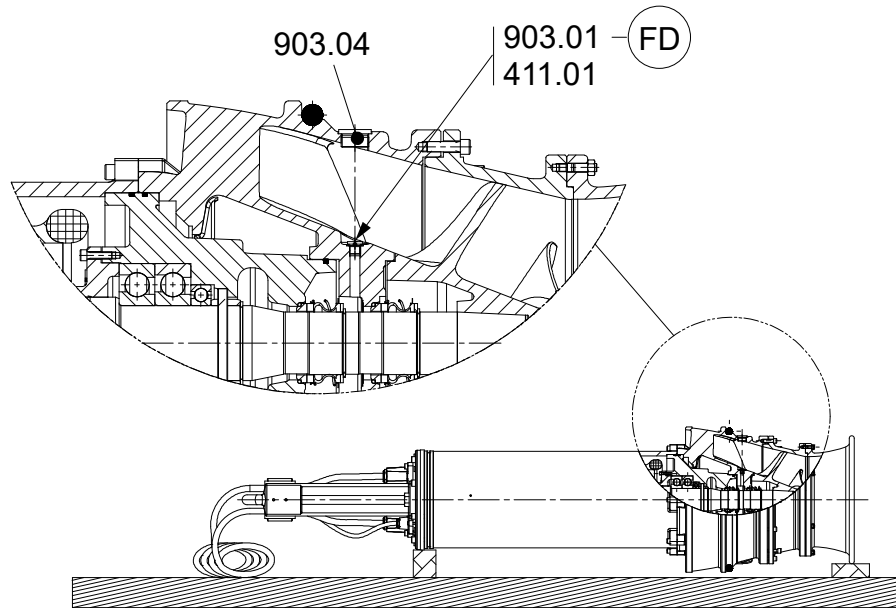





Fig. 41: Filling in the lubricant

Table 24: Symbols key

Symbol	Description
	Always apply a liquid sealant (e.g. Hylomar SQ32M) to sealing surfaces marked with this symbol.

- ✓ Screw plug 903.06 has been screwed in with joint ring 411.06.
 - ✓ The pump set has been placed in a horizontal position and protected against rolling away.
1. Remove screw plug 903.04.
 2. Remove screw plug 903.01 and joint ring 411.01.
 3. Screw in a sufficiently long tube with G 1/4 thread.
 4. Fill the lubricant in through the tube.
 5. Remove the tube. Apply a liquid sealant to screw plug 903.01. Screw the plug in together with a new joint ring 411.01.
 6. Screw in screw plug 903.04.

7.4.2 Lubrication and lubricant change of rolling element bearings

	<p> WARNING</p>
	<p>Shaft seal ring overheating Explosion hazard! Bearings overheating!</p> <p>▷ As part of the re-greasing procedure, also re-grease the sealing lip of shaft seal ring 421.02.</p>

The pump set is equipped with grease-lubricated, maintenance-free rolling element bearings.

7.4.2.1 Intervals

Change the grease when carrying out a general overhaul but at least every 5 years. In addition, having the rolling element bearings replaced by KSB Service is recommended.

7.4.2.2 Grease quality

	CAUTION
	<p>Mix of different grease types Damage to the pump set!</p> <ul style="list-style-type: none"> ▷ Make sure to use the right type of grease. ▷ Never mix different types of grease.

The following greases can be used to lubricate the rolling element bearings:

Table 25: Lubricant characteristics

Base oil	Type	Thickener	NLGI grade (ISO 2137)	Worked penetration at 25 °C, 0.1 mm (ISO 2137)	Drop point (ISO 2176) [°C]	Application temperature range [°C]	Viscosity (DIN 51562) [mm ² /s]	
							at 40 °C	at 100 °C
Ester oil	A	Polyurea	2	265 to 295	> 250	-40 to +180	100	11

The re-lubrication and maintenance intervals apply to the grease type originally used by the manufacturer:

- Type A: Klüberquiet BQH 72-102, made by Klüber Lubrication KG, München







7.4.2.3 Grease quantity



Table 26: Grease quantity

Size Pump	Size Motor	Grease type	Grease quantity	
			Drive end	Pump end
			[cm ³]	[cm ³]
600 - 390	70 4 ... 130 4	Type A	30	450
	47 6 ... 80 6	Type A	30	450
600 - 420	70 4 ... 130 4	Type A	30	450
700 - 460	90 4 ... 130 4	Type A	30	450
	47 6 ... 120 6	Type A	30	450
	150 4 ... 215 4	Type A	30	800
	155 6	Type A	30	800
800 - 460	275 4 ... 300 4	Type A	30	800
800 - 580	80 6 ... 120 6	Type A	30	450
	155 6 ... 340 6	Type A	30	800
900 - 630	155 6 ... 205 6	Type A	30	800
	250 6 ... 340 6	Type A	30	1300
900 - 650	155 6 ... 205 6	Type A	30	800
	250 6 ... 340 6	Type A	30	1300

7.5 Dismantling the pump set

7.5.1 General information/Safety regulations

	<p>⚠ DANGER</p> <p>Improper transport Danger to life from falling parts! Damage to the pump set!</p> <ul style="list-style-type: none"> ▷ Use the attachment point provided (eyebolt, lifting lug or bail) for attaching lifting accessories. ▷ Never suspend the pump set by its power cable. ▷ Never use the lifting ropes included in KSB's scope of supply for lifting loads other than the KSB product supplied. ▷ Securely attach the lifting ropes to the pump and crane.
	<p>⚠ DANGER</p> <p>Hazardous voltage Danger of death from electric shock!</p> <ul style="list-style-type: none"> ▷ Observe the safety rules for electrical work. ▷ Disconnect the equipment from the power supply. ▷ Secure the equipment against unintentional start-up. ▷ Verify that the equipment is de-energised. ▷ Earth and short-circuit the medium-voltage components. ▷ Cover any adjacent components that are connected to the power supply.
	<p>⚠ WARNING</p> <p>Unqualified personnel performing work on the pump (set) Risk of injury!</p> <ul style="list-style-type: none"> ▷ Always have repair work and maintenance work performed by specially trained, qualified personnel.
	<p>⚠ WARNING</p> <p>Hot surface Risk of injury!</p> <ul style="list-style-type: none"> ▷ Allow the pump set to cool down to ambient temperature.
	<p>⚠ WARNING</p> <p>Improper lifting/moving of heavy assemblies or components Personal injury and damage to property!</p> <ul style="list-style-type: none"> ▷ Use suitable transport devices, lifting equipment and lifting tackle to move heavy assemblies or components.
	<p>⚠ WARNING</p> <p>Excess pressure inside the pump set Risk of injury when opening the pump set!</p> <ul style="list-style-type: none"> ▷ Take care when opening the inner chambers. Equalise the pressure.

	<p>⚠ WARNING</p> <p>Components with sharp edges Risk of cutting or shearing injuries!</p> <ul style="list-style-type: none"> ▷ Always use appropriate caution for installation and dismantling work. ▷ Wear work gloves.
	<p>⚠ WARNING</p> <p>Pump set tilting or rolling off Risk of personal injury!</p> <ul style="list-style-type: none"> ▷ Make sure the pump set is secured against tilting during the entire dismantling process. ▷ For dismantling the pump set in a horizontal position, secure it against rolling off.

Observe the general safety instructions and information.

For dismantling and reassembly observe the general assembly drawing.

In the event of damage you can always contact our service departments.

7.5.2 Preparing the pump set

1. De-energise the pump set and secure it against unintentional start-up.
2. Remove the pump set from the discharge tube. (⇒ Section 7.3.1, Page 59)
3. Clean the pump set. (⇒ Section 7.3.2, Page 61)
4. Drain the lubricant. (⇒ Section 7.4.1.4, Page 64)
5. Drain the leakage chamber and leave it open for the duration of the disassembly.

7.5.3 Removing the bellmouth and casing wear ring

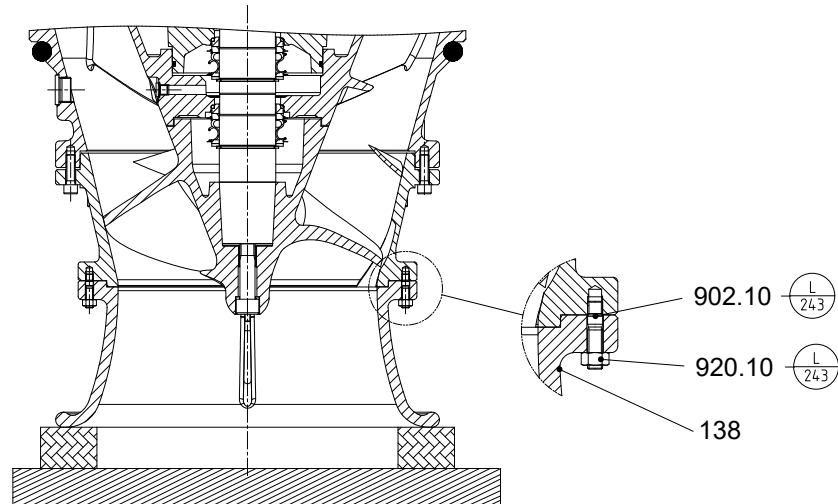

Fig. 42: Removing the bellmouth

- ✓ The pump set has been disconnected from the power supply and secured against unintentional start-up.
 - ✓ The pump set has been placed in a vertical position with the bellmouth on wooden supports. It has been secured against tipping over.
1. Undo hexagon socket head cap screws 914.12.
 2. Attach the crane hook to the bail. Lift the pump set off casing wear ring 502.
 3. Place the pump set down in a horizontal position on wooden supports. Secure it against rolling away.
 4. Remove nuts 920.10 from studs 902.10. Store them carefully.

7.5.4 Removing the impeller

7.5.4.1 Overview of impeller design

For removing/fitting the impeller a difference is made between impeller with tapered fit and impeller with cylindrical fit.

Table 27: Description

Pump size	Motor size	Efficiency class	Impeller with ...
600 - 390	70 4 ... 130 4	-	Tapered fit
	47 6 ... 80 6	IE3	Tapered fit
600 - 420	70 4 ... 130 4	-	Tapered fit
		IE3	Tapered fit
700 - 460	90 4 ... 130 4	-	Tapered fit
	47 6 ... 120 6	IE3	Tapered fit
	150 4 ... 215 4	-	Cylindrical fit
800 - 460	275 4 ... 300 4	IE3	Cylindrical fit
800 - 580	80 6 ... 120 6	-	Cylindrical fit
	155 6 ... 205 6	-	Cylindrical fit
	250 6 ... 340 6	IE3	Cylindrical fit
900 - 630	155 6 ... 205 6	-	Cylindrical fit
	250 6 ... 340 6	-	Cylindrical fit
		IE3	Cylindrical fit
900 - 650	155 6 ... 205 6	-	Cylindrical fit
	250 6 ... 340 6	-	Cylindrical fit
		IE3	Cylindrical fit

1581.85/01-EN

7.5.4.2 Removing the impeller with tapered fit

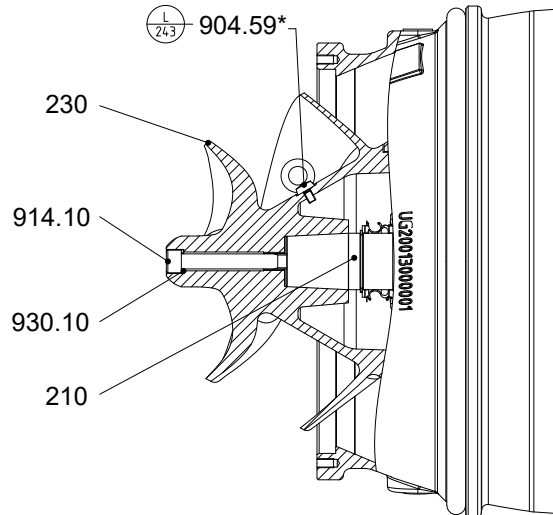
Fig. 43: Removing the impeller with tapered fit

* Does not apply to sizes 600-390, 700-390, 600-420 and 700-420.

- ✓ The pump set has been placed in a horizontal position on wooden supports. It has been secured against rolling away.
 - ✓ The lubricant and any leakage have been drained.
 - ✓ The bellmouth and casing wear ring have been removed.
1. Undo grub screw 904.59. Screw in an eyebolt. Attach the lifting equipment. On sizes 600-390, 700-390, 600-420 and 700-420 no drilled hole for the eyebolt is provided.
 2. Undo hexagon socket head cap screw 914.10. Remove it together with lock washer 930.10.
 3. Screw the forcing screw into the impeller hub. Remove impeller 230 from shaft 210.

7.5.4.3 Removing the impeller with cylindrical fit

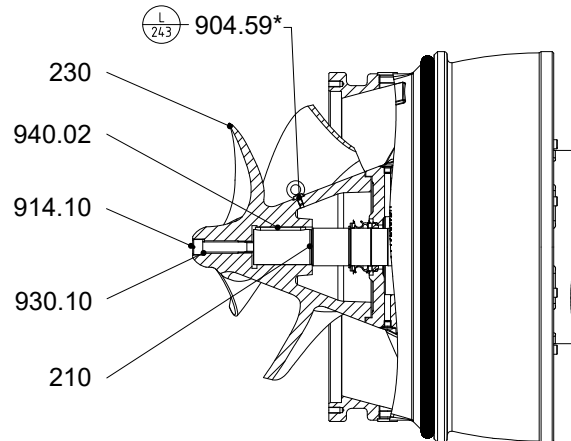

Fig. 44: Removing the impeller with cylindrical fit

* Does not apply to sizes 600-390, 700-390, 600-420 and 700-420.

- ✓ The pump set has been placed in a horizontal position on wooden supports. It has been secured against rolling away.
 - ✓ The lubricant and any leakage have been drained.
 - ✓ The bellmouth and casing wear ring have been removed.
1. Undo grub screw 904.59. Screw in an eyebolt. Attach the lifting equipment. On sizes 600-390, 700-390, 600-420 and 700-420 no drilled hole for the eyebolt is provided.
 2. Undo hexagon socket head cap screw 914.10. Remove it together with lock washer 930.10.
 3. Pull impeller 230 off shaft 210.
 4. Remove key 940.02 from shaft 210. Store it carefully.

7.5.5 Removing the mechanical seal

7.5.5.1 Impeller-end mechanical seal

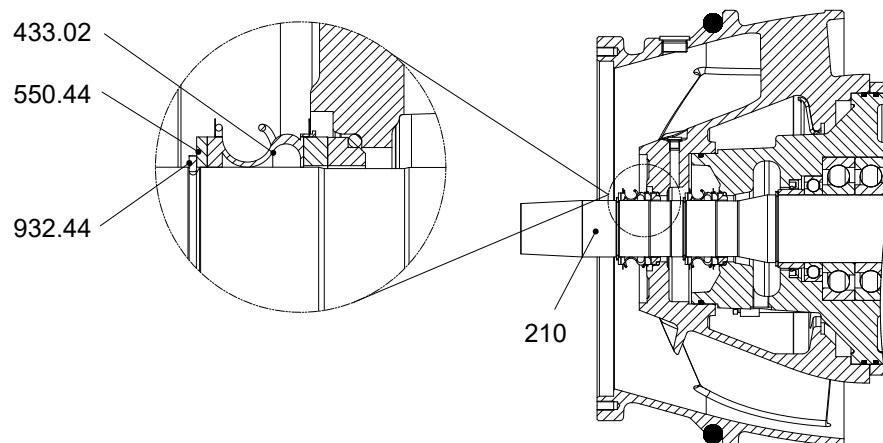





Fig. 45: Removing the impeller-end mechanical seal

- ✓ The pump set has been placed in a horizontal position on wooden supports. It has been secured against rolling away. (⇒ Section 3.2, Page 13)
 - ✓ The impeller has been removed.
1. Remove circlip 932.44 and disc 550.44.
 2. Carefully pull mechanical seal 433.02 and its mating ring off the shaft.
 - ⇒ If, unlike in the illustration, a HJ97G mechanical seal has been fitted, also undo the grub screws at the mechanical seal. Carefully pull the mechanical seal off the shaft.

	NOTE
	To protect the mechanical seal against damage when pulling it off the shaft, placing a foil (no thicker than 0.03 mm) around the free shaft end is recommended.

7.5.5.2 Drive-end mechanical seal

	 DANGER
	<p>Improper lifting/moving/transporting of heavy assemblies or components Danger to life from falling parts! Damage to the pump set!</p> <ul style="list-style-type: none"> ▷ Never rotate the rotor in the motor housing during dismantling/reassembly. ▷ Place the motor (unit) including rotor and bearing housing on a wooden support and protect it against rolling off.

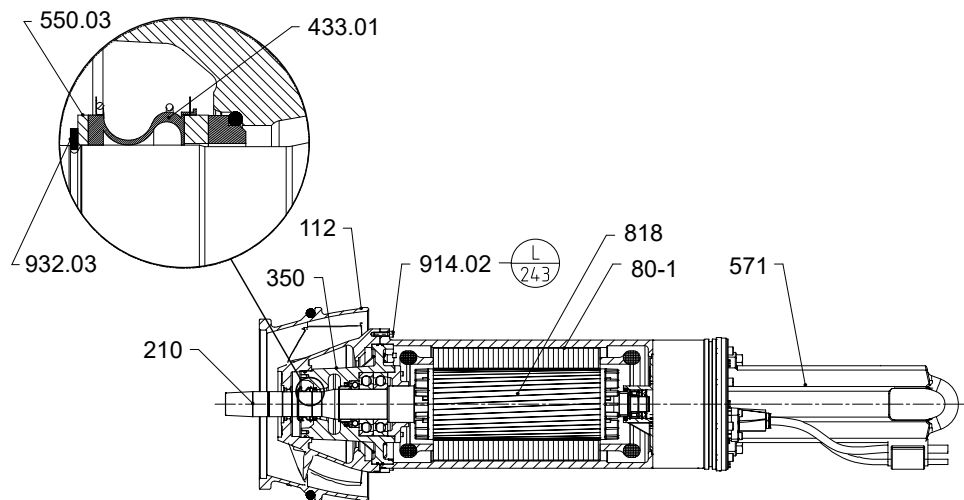



Fig. 46: Removing the drive-end mechanical seal

Table 28: Symbols key

Symbol	Description
	Always secure screwed connections marked with this symbol with Loctite 243 .

- ✓ The impeller-end mechanical seal has been removed.
- 1. Attach the pump set to bail 571 and pull it upright.
- 2. Place the pump set with pump bowl 112 down on the casing wear ring again.
- 3. Undo hexagon socket head cap screws 914.02.
- 4. Attach the lifting tackle to bail 571 and lift the pump set out of pump bowl 112.
- 5. Place motor unit 80-1 including rotor 818 with the bearing assembly and bearing housing 350 on a wooden support and secure it against rolling away.
- 6. Remove circlip 932.03 and disc 550.03.
- 7. Carefully pull mechanical seal 433.01 and its mating ring off the shaft.

	NOTE
	To protect the mechanical seal against damage when pulling it off the shaft, placing a foil (no thicker than 0.03 mm) around the free shaft end is recommended.

7.5.6 Dismantling the motor section

	NOTE
	Special regulations apply to repair work on explosion-proof pump sets. Modifications or alteration of the pump set may affect explosion protection and are only permitted after consultation with the manufacturer.
	NOTE
	The motors of explosion-proof pump sets are supplied in "flameproof enclosure" type of protection. Any work on the motor section which could affect explosion protection, such as re-winding and repair work involving machining, must be inspected and approved by an approved expert or performed by the motor manufacturer. No modifications must be made to the internal configuration of the motor space. Repair work at the flameproof joints must only be performed in accordance with the manufacturer's instructions. Repair in accordance with the values specified in EN 60079-1 Table 2 is not permitted.

When dismantling the motor section and the electric cables make sure that the cores/terminals are clearly marked for future reassembly.

7.5.6.1 Removing the motor housing cover

Pump set with standard sensors

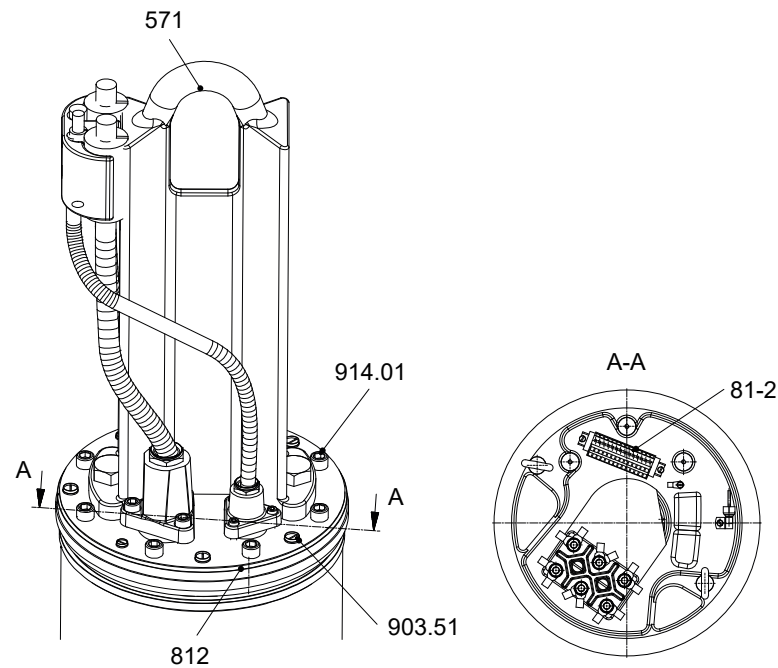

Fig. 47: Removing the motor housing cover, pump set with standard sensors

- ✓ Suitable lifting equipment is available.
 - ✓ The pump set has been disconnected from the power supply. It has been securely placed on a level/even surface in a vertical position.
1. Attach bail 571 to the lifting equipment.
 2. Undo hexagon socket head cap screws 914.01.
 3. Carefully lift off motor housing cover 812. If the motor housing cover cannot be lifted off, use the jacking threads located underneath caps 903.51.
 4. Remove the cable ties.
 5. Lift motor housing cover 812 up further until the power cables and sensor cable can be disconnected.

6. Disconnect plug 81-2 of the sensor cable from the corresponding connector.
7. Disconnect the cores of the power cable at terminal board 835.
8. Place motor housing cover 812 down. Secure it against rolling away.

Pump set with sensor system

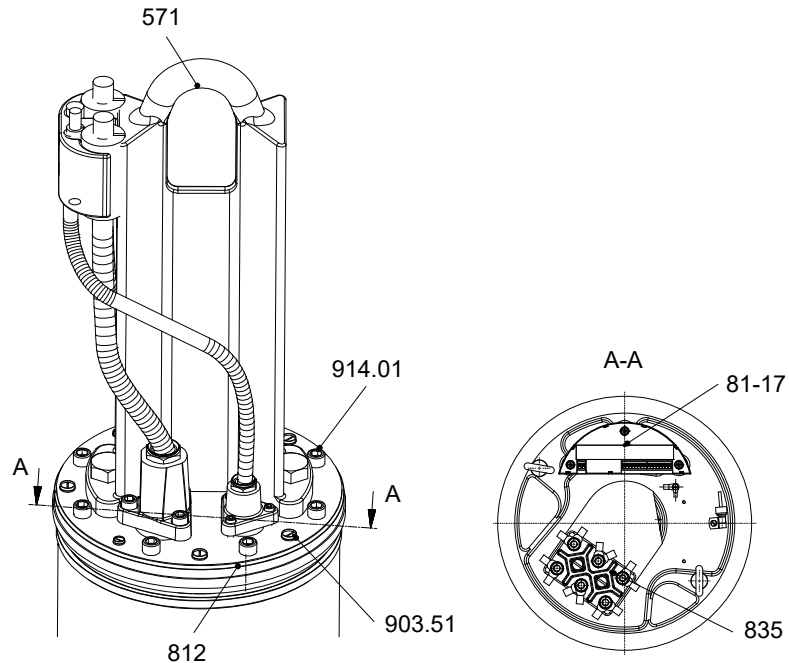

Fig. 48: Removing the motor housing cover, pump set with sensor system

- ✓ Suitable lifting equipment is available.
 - ✓ The pump set has been disconnected from the power supply. It has been securely placed on a level/even surface in a vertical position.
1. Attach bail 571 to the lifting equipment.
 2. Undo hexagon socket head cap screws 914.01.
 3. Carefully lift off motor housing cover 812. If the motor housing cover cannot be lifted off, use the jacking threads located underneath caps 903.51.
 4. Remove the cable ties.
 5. Lift motor housing cover 812 up further until the power cables and sensor cable can be disconnected.
 6. Undo the cores of the sensor cable from sensor module 82-17.
 7. Disconnect the cores of the power cable at terminal board 835.
 8. Place motor housing cover 812 down. Secure it against rolling away.

7.5.6.2 Removing the cable gland and connection cable

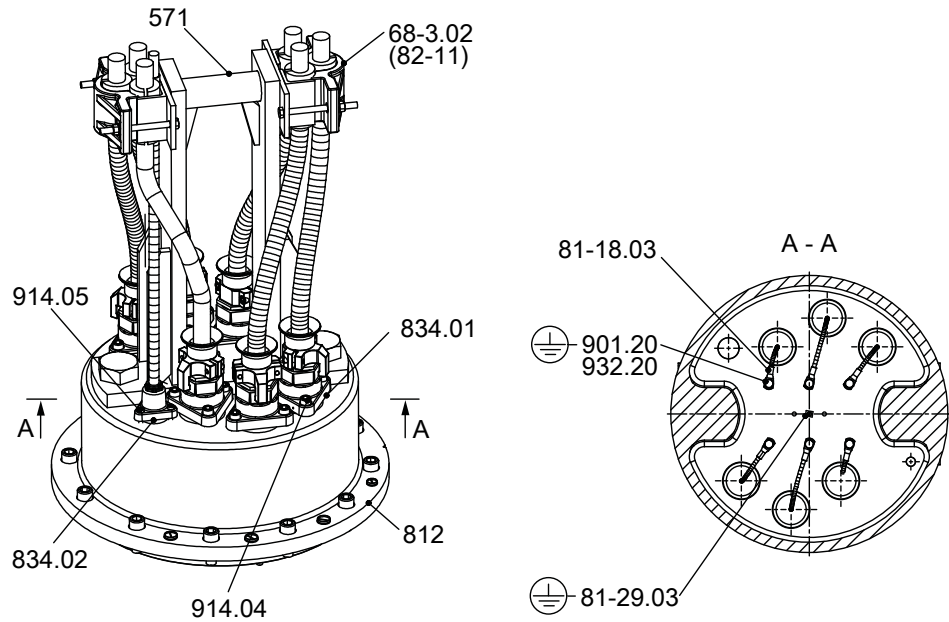

Fig. 49: Removing the cables and cable gland

Removing the power cable

✓ The motor housing cover has been removed, placed down and protected against rolling off.

1. Remove cover plate 82-11 or 68-3.02 from bail 571. Take out the cable gland 834.01/02 needing to be replaced.
2. Disconnect the earth connector on the inside of motor housing cover 812. If a shielded cable is used, disconnect the shield as well.
3. Undo screws 914.04 at cable gland 834.01.
4. Pull cable gland 834.01 out of the centring seat in motor housing cover 812.

Removing the sensor cable

✓ The motor housing cover has been removed, placed down and protected against rolling off.

1. Disconnect the cores of the sensor cable from plug 81-2.
2. Undo screws 914.05 at cable gland 834.02.
3. Pull cable gland 834.02 out of the centring seat in motor housing cover 812.







	NOTE
Keeping a record of the core identification and lengths is recommended. This will facilitate installing the replacement cable gland.	



7.6 Reassembling the pump set

7.6.1 General information/Safety regulations

	DANGER
	<p>Wrong screws/bolts Explosion hazard!</p> <ul style="list-style-type: none"> ▷ Always use the original screws/bolts for assembling an explosion-proof pump set. ▷ Never use screws/bolts of different dimensions or of a lower property class.

1581.85/01-EN

	<p>⚠ DANGER</p> <p>Improper lifting/moving/transporting of heavy assemblies or components Danger to life from falling parts! Damage to the pump set!</p> <ul style="list-style-type: none"> ▷ Never rotate the rotor in the motor housing during dismantling/reassembly. ▷ Place the motor (unit) including rotor and bearing housing on a wooden support and protect it against rolling off.
	<p>⚠ WARNING</p> <p>Screwed/bolted connections working loose Risk of injury!</p> <ul style="list-style-type: none"> ▷ If persons come into contact with the fluid handled during pump operation (e.g. in sports facilities and leisure parks), apply a thread-locking agent (Loctite, type 243) to all screwed/bolted connections that are in contact with the fluid handled. Do not apply the thread-locking agent (Loctite, type 243) to the screw plugs.
	<p>⚠ WARNING</p> <p>Improper lifting/moving of heavy assemblies or components Personal injury and damage to property!</p> <ul style="list-style-type: none"> ▷ Use suitable transport devices, lifting equipment and lifting tackle to move heavy assemblies or components.
	<p>⚠ WARNING</p> <p>Components with sharp edges Risk of cutting or shearing injuries!</p> <ul style="list-style-type: none"> ▷ Always use appropriate caution for installation and dismantling work. ▷ Wear work gloves.
	<p>⚠ WARNING</p> <p>Insufficient stability Risk of crushing hands and feet!</p> <ul style="list-style-type: none"> ▷ During assembly/dismantling, secure the pump (set)/pump parts to prevent tilting or tipping over.
	<p>CAUTION</p> <p>Improper reassembly Damage to the pump!</p> <ul style="list-style-type: none"> ▷ Reassemble the pump (set) in accordance with the general rules of sound engineering practice. ▷ Use original spare parts only.

	<p>NOTE</p> <p>Before reassembling the motor section, check that all joints relevant to explosion protection (flamepaths) are undamaged. Any components with damaged flamepaths must be replaced. Only use original spare parts made by KSB for explosion-proof pumps. Observe the flamepath positions specified in the Annex (Flamepaths on explosion-proof motors). Secure all screwed/bolted connections closing off the flameproof enclosure with a thread-locking agent (Loctite Type 243).</p>
	<p>NOTE</p> <p>Apply liquid sealant to all screw plugs. Apply liquid sealant to all wetted clearances (e.g. Hylomar SQ 32M).</p>

Sequence Always reassemble the pump set in accordance with the corresponding general assembly drawing.

- Sealing elements**
- O-rings
 - Check O-rings for any damage and replace by new O-rings if required.
 - Never use O-rings that have been made by cutting an O-ring cord to size and gluing the ends together.
 - Assembly adhesives
 - Avoid the use of assembly adhesives if possible.

Tightening torques For reassembly, tighten all screws and bolts as specified in this manual. (⇒ Section 7.9, Page 92)
In addition, secure all screwed/bolted connections closing off the flameproof enclosure with a thread-locking agent (Loctite, type 243).

7.6.2 Installing the replacement cable gland

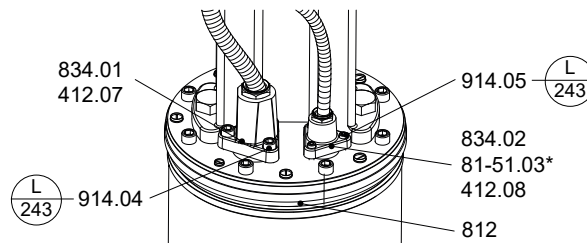



Fig. 50: Installing the cable gland
* Only fitted on pump set with sensor system.

Table 29: Symbols key

Symbol	Description
	Always secure screwed connections marked with this symbol with Loctite 243 .

Installing the power cable

- ✓ The motor housing cover has been removed, placed down and protected against rolling away.
1. Adjust the lengths of the cable cores to those of the original cable gland.
 2. Attach core identifications matching the original cable gland.
 3. Slide O-ring 412.07 onto the core ends of the power cable and into the groove of the centring seat.
 4. Insert cable gland 834.01 with the power cable and O-ring 412.07 into the opening provided.
 5. Fasten cable gland 834.01 with hexagon socket head cap screws 914.04. Secure the screwed connection with Loctite 243.
 6. Fit cable terminals to the core ends of the power cable.

Installing the sensor cable



Pump set with standard sensors

- ✓ The motor housing cover has been removed, placed down and protected against rolling away.
- 1. Adjust the lengths of the cable cores to those of the original cable gland.
- 2. Attach core identifications matching the original cable gland.
- 3. Slide O-ring 412.08 over the short core ends of the sensor cable and into the groove of the centring seat.
- 4. Insert cable gland 834.02 with the sensor cable and O-ring 412.08 into the opening provided.
- 5. Fasten cable gland 834.02 with hexagon socket head cap screws 914.05 and secure the screwed connection with Loctite 243.

Pump set with sensor system

- ✓ The motor housing cover has been removed, placed down and protected against rolling away.
- 1. Adjust the lengths of the cable cores to those of the original cable gland.
- 2. Attach core identifications matching the original cable gland.
- 3. Slide O-ring 412.08 over the short core ends of the sensor cable and into the groove of the centring seat.
- 4. Insert cable gland 834.02 with the sensor cable and O-ring 412.08 into the opening provided.
- 5. Fasten cable gland 834.02 with clamping element 81-51.03 and hexagon socket head cap screws 914.05 and secure the screwed connection with Loctite 243.

7.6.3 Fitting the motor housing cover

	 DANGER
	Electrical connection work by unqualified personnel
	Danger to life from electric shock <ul style="list-style-type: none"> ▷ Always have the electrical connections installed by a trained electrician. ▷ Observe regulation IEC 60364 as well as the applicable regional regulations.

Pump set with standard sensors

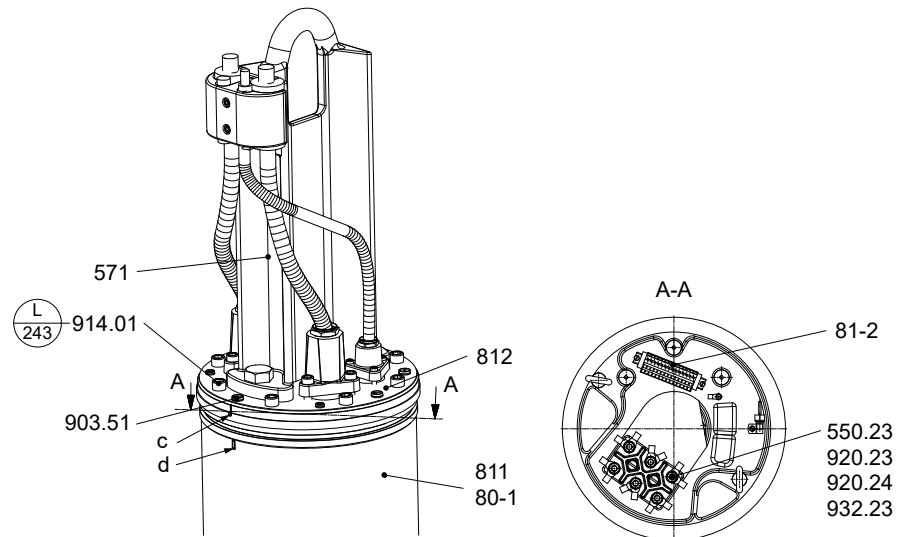

Fig. 51: Fitting the motor housing cover, pump set with standard sensors

c	Alignment grooves of motor housing cover 812
d	Alignment groove of motor housing 811

1581.85/01-EN

Table 30: Symbols key

Symbol	Description
	Always secure screwed connections marked with this symbol with Loctite 243 .

- ✓ A new O-ring has been inserted into the groove of motor housing cover 812.
- 1. Attach lifting equipment to bail 571 of motor housing cover 812.
 - ⇒ Lower motor housing cover 812 down onto motor housing 811 or motor unit 80-1 until only a gap remains which allows work to continue.
 - ⇒ Watch the alignment grooves in motor housing cover 812 and motor housing 811. The alignment grooves must be properly aligned.
- 2. Connect plug 81-2 of the sensor cable to the corresponding connector.
- 3. Connect the cores of the power cables to terminal board 835 with disc 550.23, circlip 932.23 and nuts 920.23/920.24 in accordance with the wiring diagram.
- 4. Tie the cores together with cable ties.
- 5. Slowly lower motor housing cover 812 down onto motor housing 811.
 - ⇒ Watch the alignment grooves in motor housing cover 812 and motor housing 811. The alignment grooves must be properly aligned.
- 6. Fasten motor housing cover 812 to motor housing 811 or motor unit 80-1 with socket head cap screws 914.01. Secure with Loctite 243. Observe the tightening torque.
- 7. Cover the jacking threads with caps 903.51.
- 8. Perform a leak test on the motor. (⇒ Section 7.6.8.2, Page 88)

Pump set with sensor system

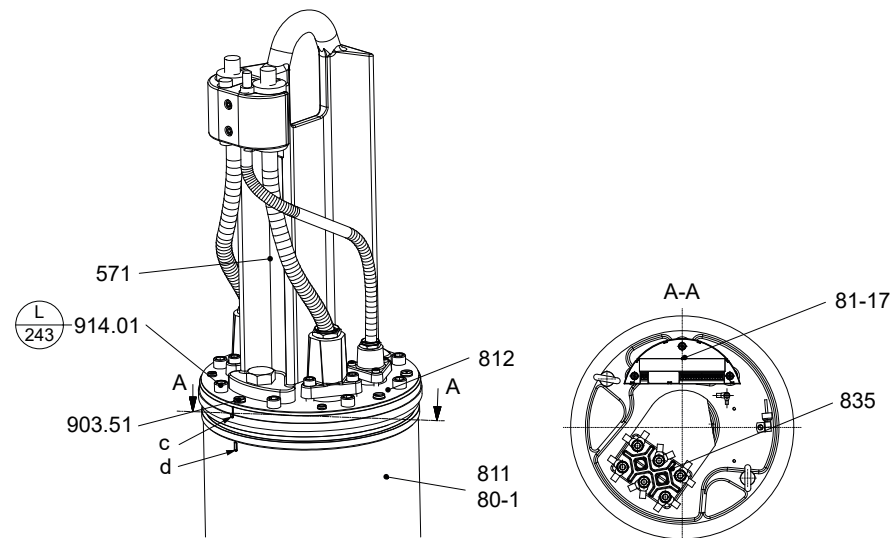

Fig. 52: Fitting the motor housing cover, pump set with sensor system

c	Alignment grooves of motor housing cover 812
d	Alignment groove of motor housing 811

Table 31: Symbols key

Symbol	Description
	Always secure screwed connections marked with this symbol with Loctite 243 .

- ✓ A new O-ring has been inserted into the groove of motor housing cover 812.
- 1. Attach lifting equipment to bail 571 of motor housing cover 812.
 - ⇒ Lower motor housing cover 812 down onto motor housing 811 or motor unit 80-1 until only a gap remains which allows work to continue.

1581.85/01-EN



- ⇒ Watch the alignment grooves in motor housing cover 812 and motor housing 811. The alignment grooves must be properly aligned.
- 2. Connect the individual cores of the sensor cable to sensor module 82-17.
- 3. Connect the cores of the power cables to terminal board 835 with disc 550.23, circlip 932.23 and nuts 920.23/920.24 in accordance with the wiring diagram.
- 4. Tie the cores together with cable ties.
- 5. Slowly lower motor housing cover 812 down onto motor housing 811.
 - ⇒ Watch the alignment grooves in motor housing cover 812 and motor housing 811. The alignment grooves must be properly aligned.
- 6. Fasten motor housing cover 812 to motor housing 811 or motor unit 80-1 with socket head cap screws 914.01. Secure with Loctite 243. Observe the tightening torque.
- 7. Cover the jacking threads with caps 903.51.
- 8. Perform a leak test on the motor. (⇒ Section 7.6.8.2, Page 88)

7.6.4 Installing the mechanical seal

Observe the following to ensure trouble-free operation of the mechanical seal:

- Only remove the protective wrapping of the contact faces immediately before assembly takes place.
- The shaft surface must be absolutely clean and undamaged.
- Immediately before installing the mechanical seal, wet the contact faces with a drop of oil.
- For easier installation of bellows-type mechanical seals, wet the inside diameter of the bellows or the O-rings with soapy water (not oil).
- Cover any grooves in the shaft into which the O-rings could slide with suitable means or assembly aids.
- To prevent any damage to the rubber bellows, place a thin foil (of approximately 0.1 to 0.3 mm thickness) around the free shaft stub.
Slide the rotating assembly over the foil into its installation position.
Then remove the foil.

7.6.4.1 Installing the drive-end mechanical seal

	 DANGER
	<p>Improper lifting/moving/transporting of heavy assemblies or components Danger to life from falling parts! Damage to the pump set!</p> <ul style="list-style-type: none"> ▷ Never rotate the rotor in the motor housing during dismantling/reassembly. ▷ Place the motor (unit) including rotor and bearing housing on a wooden support and protect it against rolling off.

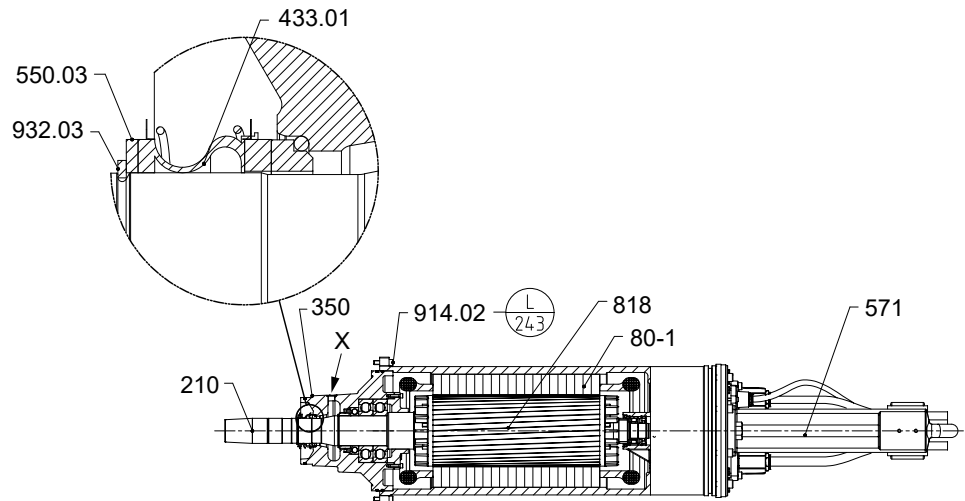

Fig. 53: Installing the drive-end mechanical seal

X	Drilled hole for testing device
---	---------------------------------

Table 32: Symbols key

Symbol	Description
	Always secure screwed connections marked with this symbol with Loctite 243 .

✓ The pump set has been positioned horizontally on suitable wooden supports and is secured against rolling away.

1. Use an assembling sleeve of a suitable diameter to insert the mating ring of mechanical seal 433.01 together with the O-ring into the drilled seat of bearing housing 350.
2. Carefully guide on the bellows part of mechanical seal 433.01 until it rests against the mating ring.
3. Guide disc 550.03 and circlip 932.03 onto the shaft. Press the circlip in with an assembly sleeve until it is axially fastened in the shaft groove.
4. Screw the testing device into the leakage drain hole (X) of bearing housing 350 and perform a leak test. (⇒ Section 7.6.4.1.1, Page 82)
5. Attach the eye hook to the bail and pull upright motor unit 80-1 including rotor 818 with bearing and bearing housing 350. (⇒ Section 3.2.2, Page 13)
6. Place the pump set on the pump bowl. Fasten it with hexagon socket head cap screws 914.02. Secure the screwed connection with Loctite 243.

7.6.4.1.1 Leak test when installing the mechanical seal

Observe the following values for leak testing:

- **Test medium:** compressed air
- **Test pressure:** 1 bar max.
- **Test period:** 5 minutes

1. The pressure must not drop during the test period.
If the pressure does drop, check the sealing elements and screwed connections. Then perform another leak test.
2. If the test has been successful, remove the testing device. Do not close the leakage drain hole to allow drainage of any water ingress.

7.6.4.2 Impeller-end mechanical seal

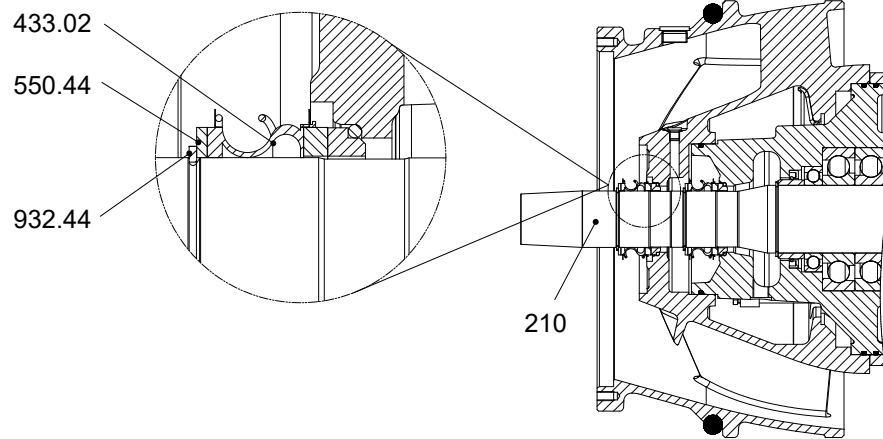

Fig. 54: Installing the impeller-end mechanical seal

- ✓ The pump bowl has been fastened to the motor.
 - ✓ The pump set has been positioned horizontally on a wooden support. It has been secured against rolling away.
1. Use an assembly sleeve of a suitable diameter to press the mating ring of mechanical seal 433.02 together with the O-ring into the drilled recess in the pump bowl.
 2. Carefully guide on the bellows part of the mechanical seal until it rests against the mating ring.
 3. Slide disc 550.44 and circlip 932.44 onto the shaft. Press the circlip in with an assembly sleeve until it is axially fastened in the shaft groove.
 - ⇒ If, unlike in the illustration, a HJ97G mechanical seal has been fitted, also tighten the grub screws at the mechanical seal.
 4. Check the lubricant chamber for leakage. (⇒ Section 7.6.8.1, Page 88)
 5. Fill the lubricant reservoir with lubricant. Then close the lubricant reservoir. (⇒ Section 7.4.1.4.2, Page 66)

7.6.5 Fitting the impeller

7.6.5.1 Overview of impeller design

For removing/fitting the impeller a difference is made between impeller with tapered fit and impeller with cylindrical fit.

Table 33: Description

Pump size	Motor size	Efficiency class	Impeller with
600 - 390	70 4 ... 130 4	-	Tapered fit
	47 6 ... 80 6	IE3	Tapered fit
600 - 420	70 4 ... 130 4	-	Tapered fit
		IE3	Tapered fit
700 - 460	90 4 ... 130 4	-	Tapered fit
	47 6 ... 120 6	IE3	Tapered fit
	150 4 ... 215 4	-	Cylindrical fit
800 - 460	275 4 ... 300 4	IE3	Cylindrical fit
800 - 580	80 6 ... 120 6	-	Cylindrical fit
	155 6 ... 205 6	-	Cylindrical fit
	250 6 ... 340 6	IE3	Cylindrical fit
900 - 630	155 6 ... 205 6	-	Cylindrical fit
	250 6 ... 340 6	-	Cylindrical fit
		IE3	Cylindrical fit

Pump size	Motor size	Efficiency class	Impeller with ...
900 - 650	155 6 ... 205 6	-	Cylindrical fit
	250 6 ... 340 6	-	Cylindrical fit
		IE3	Cylindrical fit

7.6.5.2 Fitting the impeller with tapered fit

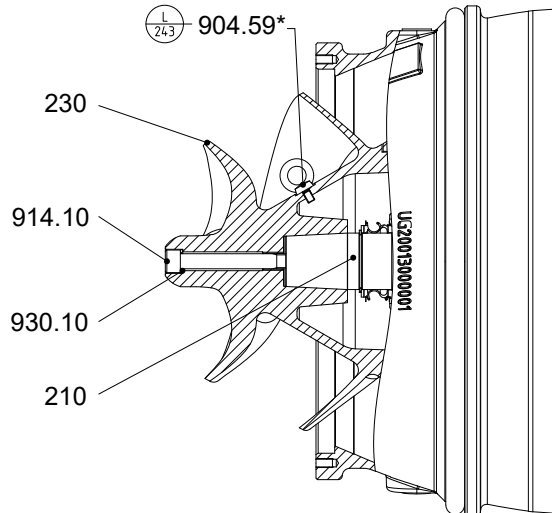

Fig. 55: Fitting the impeller with tapered fit

* Does not apply to sizes 600-390, 700-390, 600-420 and 700-420.

Table 34: Symbols key

Symbol	Description
	Always secure screwed connections marked with this symbol with Loctite 243 .

- ✓ The pump set has been placed in a horizontal position on wooden supports. It has been secured against rolling away.
- ✓ The impeller-end mechanical seal 433.02 has been installed.
- ✓ The eyebolt has been screwed into the impeller bore.⁹⁾
 1. Suspend impeller 230 and slide it onto the shaft end.
 2. Screw in impeller screw 914.10 with lock washer 930.10. Tighten with a torque wrench. Observe the tightening torques.
 3. Undo the eyebolt. Completely screw in grub screw 904.59. Secure it with Loctite 243.⁹⁾

	NOTE
	For bearing brackets with tapered fit make sure that the tapered fit of impeller and shaft is undamaged and assembled free from grease.

⁹⁾ Does not apply to sizes 600-390, 700-390, 600-420 and 700-420.

7.6.5.3 Fitting the impeller with cylindrical fit

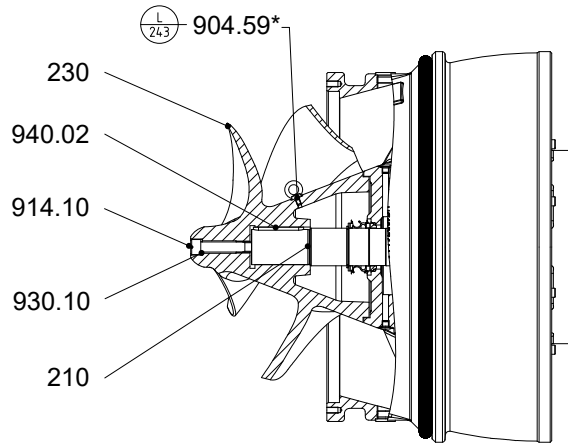

Fig. 56: Fitting the impeller with cylindrical fit

* Does not apply to sizes 600-390, 700-390, 600-420 and 700-420.

Table 35: Symbols key

Symbol	Description
	Always secure screwed connections marked with this symbol with Loctite 243 .

✓ The pump set has been placed in a horizontal position on wooden supports. It has been secured against rolling away.

✓ The impeller-end mechanical seal 433.02 has been installed.

✓ The eyebolt has been screwed into the impeller bore.¹⁰⁾

1. Insert key 940.02 into shaft 210.

2. Suspend impeller 230 and slide it onto the shaft end.

3. Apply Loctite type 243 thread-locking agent to the thread of impeller screw 914.10.

4. Screw in impeller screw 914.10 with lock washer 930.10. Tighten with a torque wrench. Observe the tightening torques.

5. Undo the eyebolt. Completely screw in grub screw 904.59. Secure it with Loctite 243.¹⁰⁾

7.6.6 Fitting the casing wear ring

✓ Bellmouth 138 and casing wear ring 502 have been positioned on wooden supports on a level/even and solid surface.

✓ Suitable lifting equipment is available.

✓ The pump set has been completely pre-assembled.

✓ Nuts 920.10 have been removed from studs 902.10.

✓ The casing wear ring has been checked for wear. If necessary, the casing wear ring has been replaced.

✓ The thread of hexagon socket head cap screws 914.24 protrudes from casing wear ring 502 by at least reference dimension B.

1. Suspend the pump set from bail 571. Carefully pull it upright.

2. Centre the pump set above bellmouth 138. NOTE: Casing wear ring 502 is loosely positioned on bellmouth 138.

3. Slowly lower the pump set.

⇒ During the lowering process, align the tapped blind holes in pump bowl 112 with the throughholes in casing wear ring 502.

¹⁰⁾ Does not apply to sizes 600-390, 700-390, 600-420 and 700-420.

- ⇒ As an alignment aid, one or several studs can be screwed into the tapped blind holes of pump bowl 112.
- 4. Fully lower the pump set onto casing wear ring 502.
- 5. Screw in all socket head cap screws 914.12. Only tighten them lightly.
- 6. Lift the pump set off bellmouth 138. Place it down in a horizontal position on suitable wooden supports. Secure it against rolling away.

7.6.6.1 Adjusting the clearance

	<p>⚠ WARNING</p>
	<p>Improper removal Risk of injury from falling parts!</p> <p>▷ When adjusting the clearance, never undo all hexagon socket head cap screws 914.12 at the same time.</p>

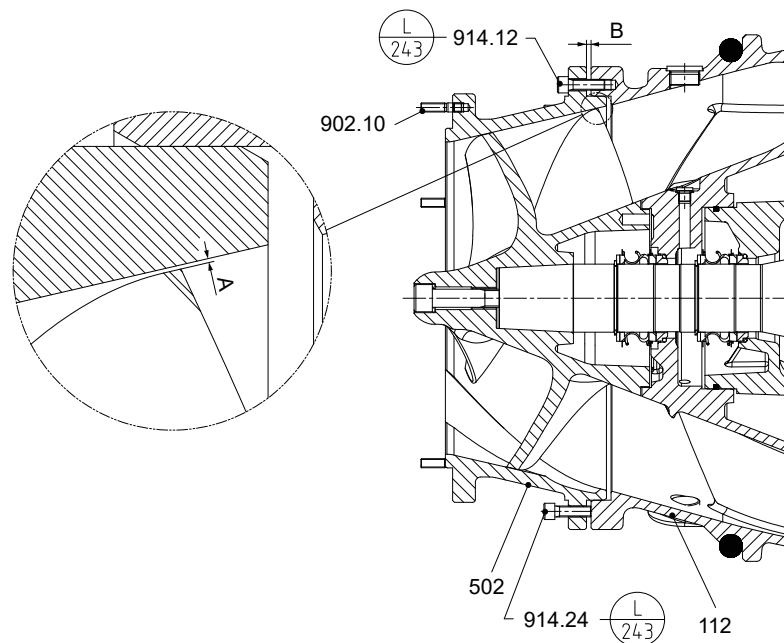

Fig. 57: Adjusting the clearance

Table 36: Symbols key

Symbol	Description
	Always secure screwed connections marked with this symbol with Loctite 243 .

- ✓ The pump set has been placed in a horizontal position on wooden supports. It has been secured against rolling away.
- ✓ The pump set has been completely assembled.
- 1. Undo hexagon socket head cap screws 914.12. Wet them with Loctite 243 one after the other. Re-insert the hexagon socket head cap screws again.
- 2. Wet hexagon socket head cap screws 914.24 with Loctite 243 one after the other.
- 3. Adjusting the clearance
 - ⇒ If clearance A is too small, loosen all hexagon socket head cap screws 914.12 evenly and, at the same time, tighten hexagon socket head cap screws 914.24 evenly.

- ⇒ If clearance A is too large, loosen all hexagon socket head cap screws 914.24 evenly and, at the same time, tighten hexagon socket head cap screws 914.12 evenly.
- 4. Measure clearance A between impeller vane and casing wear ring at the vane trailing edge of the impeller with a feeler gauge. The remaining clearance should not be smaller than 0.15 mm in any place.
- 5. When clearance A has been adjusted correctly, tighten hexagon socket head cap screws 914.12. Then tighten hexagon socket head cap screws 914.24. Observe the tightening torque.
- 6. Check by rotating the pump rotor by hand.
 - ⇒ During rotation the impeller must not touch any part of the casing.
- 7. If necessary, re-adjust the clearance.

Table 37: Clearances A and B

Size	Clearance A	Reference clearance B
	[mm]	[mm]
600/700-390 A3	0,30 +/-0,05	3,8
600/700-390 B3/B2	0,30 +/-0,05	3,6
600/700-420 A3	0,30 +/-0,05	4,3
600/700-420 B3/B2	0,30 +/-0,05	4,0
700/800-460 A3	0,30 +/-0,05	3,8
700/800-460 B3/B2	0,30 +/-0,05	3,6
800-580 A3	0,35 +/-0,05	4,6
800-580 B3/B2	0,35 +/-0,05	4,1
900-630 A3	0,35 +/-0,05	3,9
900-630 B3/B2	0,35 +/-0,05	3,8
900/1000-650 A3	0,40 +/-0,05	4,8
900/1000-650 B3/B2	0,40 +/-0,05	4,3

7.6.7 Fitting the bellmouth

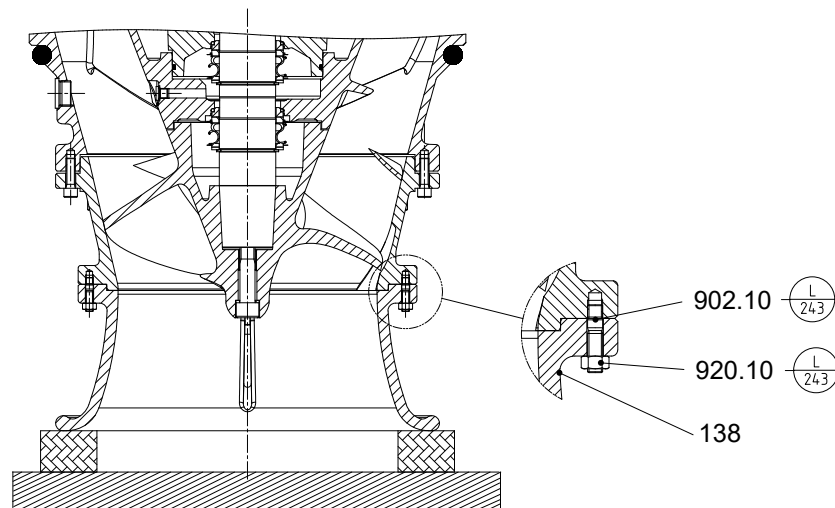



Fig. 58: Fitting the bellmouth

1581.85/01-EN

Table 38: Symbols key

Symbol	Description
	Always secure screwed connections marked with this symbol with Loctite 243 .

- ✓ Bellmouth 138 has been positioned on wooden supports on a level/even and solid surface.
- ✓ Suitable lifting equipment is available.
- ✓ The pump set has been completely pre-assembled.
 1. Attach the pump set to bail 571 and pull it upright.
 2. Centre the pump set above bellmouth 138.
 - ⇒ Verify that the alignment grooves are properly aligned.
 3. Slowly lower the pump set.
 - ⇒ While lowering the pump set, make sure that studs 902.01 are aligned with the drilled holes.
 4. Then lower the pump set until it sits on bellmouth 138.
 5. Fasten all studs 902.10 with corresponding nuts 920.10. Secure with Loctite 243. Observe the tightening torque. (⇒ Section 7.9, Page 92)

7.6.8 Leak testing

7.6.8.1 Testing the lubricant reservoir for leakage

After reassembly, the mechanical seal area/lubricant reservoir must be checked for leakage. The leak test is performed at the lubricant filler opening.

Observe the following values for leak testing:

- **Test medium:** compressed air
- **Test pressure:** 1 bar maximum
- **Test duration:** 5 minutes

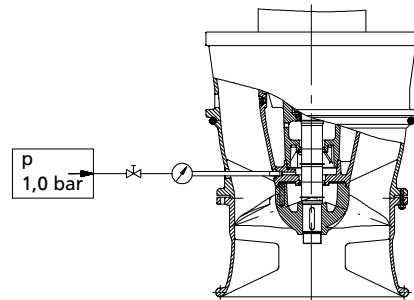

Fig. 59: Screwing in the testing device

1. Unscrew and remove the screw plug and joint ring of the lubricant reservoir.
2. Screw the testing device tightly into the lubricant filler opening.
3. Carry out the leak test with the values specified above.
 - The pressure must not drop during the test period.
 - If the pressure does drop, check the seals and screwed connections.
 - Then perform another leak test.
4. If the leak test has been successful, fill in the lubricant.

7.6.8.2 Checking the motor for leakage

Observe the following values for leak testing:

- **Test medium:** nitrogen
- **Test pressure:** 0.8 bar maximum
- **Test duration:** 2 minutes

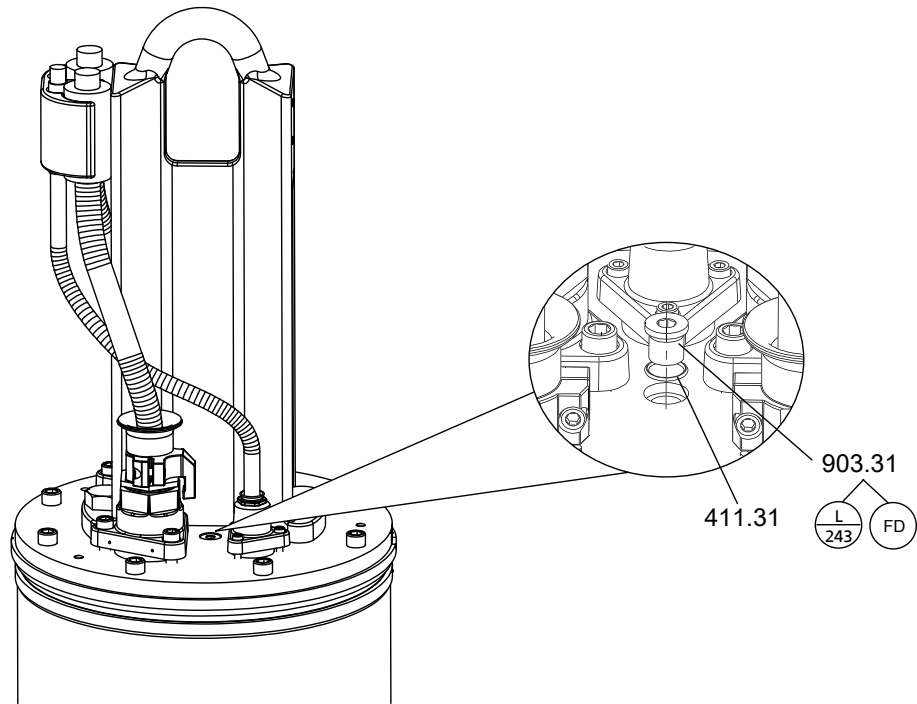

Fig. 60: Checking the motor for leakage

Table 39: Symbols key

Symbol	Description
	Always secure screwed connections marked with this symbol with Loctite 243 .
	Always apply a liquid sealant (e.g. Hylomar SQ32M) to sealing surfaces marked with this symbol.

1. Remove screw plug 903.31 and joint ring 411.31.
2. Screw the testing device tightly into the G 1/2 plug thread.
3. Carry out the leak test with the values specified above.
 - ⇒ The pressure must not drop during the test period.
 - ⇒ If the pressure does drop, check the seals and screwed connections.
4. Repeat the leak test if required.
5. Remove the testing device.

 	DANGER
	<p>Screw plug leaking or missing Explosion hazard! Damage to the motor!</p> <ul style="list-style-type: none"> ▸ Never start up a pump set without fitting the screw plug. ▸ Apply a thread-locking agent (Loctite 243) to the screw plug.

6. Apply a thread-locking agent (Loctite 243) to screw plug 903.31.
7. Re-insert and tighten screw plug 903.31 with new joint ring 411.31.

7.7 Checking the electrical connection and motor

Once reassembly has been completed, carry out the steps described in (⇒ Section 7.2.1, Page 57) and (⇒ Section 7.3.5, Page 61) .

7.8 Replacing the sacrificial anode

7.8.1 Interval

On pump sets with sacrificial anodes (material variant G3), the sacrificial anodes must initially be checked after 6 months. If necessary, the sacrificial anodes must be replaced.

- If the sacrificial anodes show little wear, the maintenance interval can be extended to 12 months.
- Replace the sacrificial anodes at least every 5 years or every 16,000 operating hours.

7.8.2 Replacing the sacrificial anodes at the bail

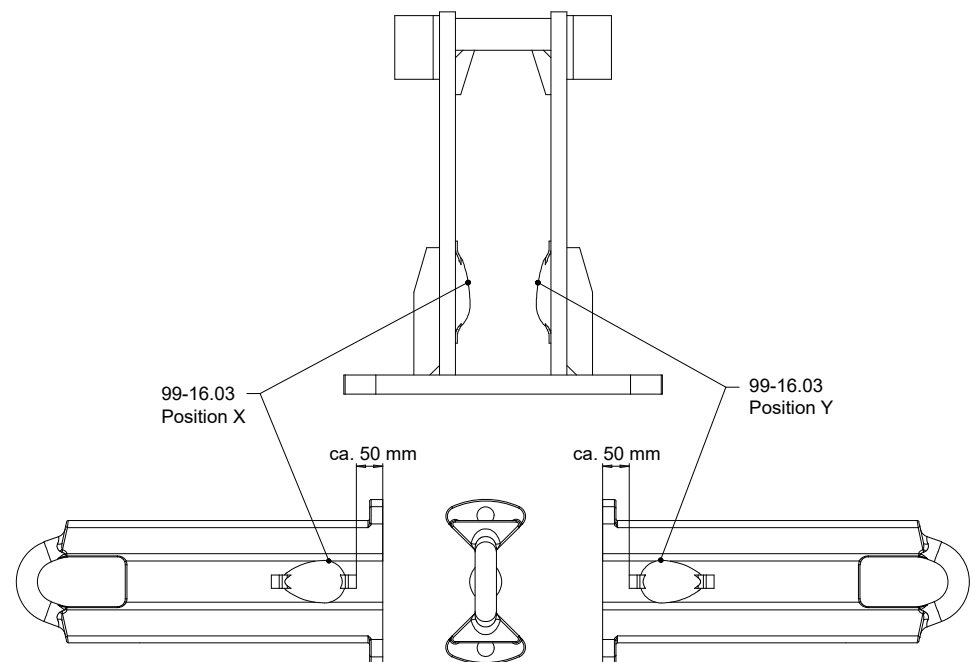

Fig. 61: Positions of sacrificial anodes at the bail

Table 40: Combinations of sacrificial anodes at the bail

Size	Quantity and weight		Material of sacrificial anodes
	For position X	For position Y	
600 - 390	1x0,9 kg	0 kg	Zinc
600 - 420	1x0,9 kg	0 kg	Zinc
700 - 390	1x0,9 kg	0 kg	Zinc
700 - 420	1x0,9 kg	0 kg	Zinc
700 - 460	1x0,9 kg	0 kg	Zinc
800 - 460	1x0,9 kg	0 kg	Zinc
800 - 580	1x0,9 kg	0 kg	Zinc
900 - 630	1x0,9 kg	0 kg	Zinc
900 - 650	1x0,9 kg	0 kg	Zinc

✓ The pump set is positioned horizontally on a level/even surface and is protected against rolling away.

1. Remove sacrificial anodes 99-16.03. Clean the surface.
2. Weld new sacrificial anodes to the lugs. We recommend using new sacrificial anodes made by KSB.

7.8.3 Replacing the sacrificial anodes at the bellmouth

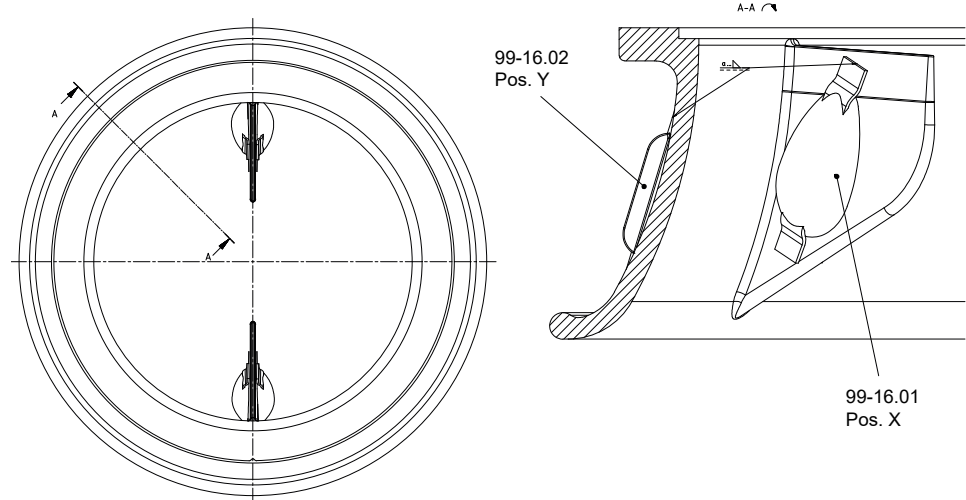

Fig. 62: Sacrificial anodes at the bellmouth

- Information on position X: Distribute the number of sacrificial anodes on both sides of the vanes. The stays for welding on may be shortened.
- Information on position Y: Evenly distribute the number of sacrificial anodes over the circumference. The stays for welding on may be shortened. Rotating the sacrificial anodes is permissible.

Table 41: Combinations of sacrificial anodes at the bellmouth

Size	Quantity and weight at position X	Quantity and weight at position Y	Material of sacrificial anodes
600 - 390	4x0,25 kg	4x0,25 kg	Zinc
600 - 420	4x0,25 kg	4x0,25 kg	Zinc
700 - 390	4x0,25 kg	4x0,25 kg	Zinc
700 - 420	4x0,25 kg	4x0,25 kg	Zinc
700 - 460	4x0,9 kg	4x0,25 kg	Zinc
800 - 460	4x0,9 kg	4x0,25 kg	Zinc
800 - 580	4x0,9 kg	4x0,25 kg	Zinc
900 - 630	4x0,9 kg	6x0,25 kg	Zinc
900 - 650	4x0,25 kg + 4x0,9 kg	6x0,25 kg	Zinc

✓ The pump set is positioned horizontally on a level/even surface and is protected against rolling away.

1. Remove sacrificial anodes 99-16.01 and 99-16.02. Clean the surface.
2. Weld new sacrificial anodes to the lugs. We recommend using new sacrificial anodes made by KSB.

7.8.4 Replacing sacrificial anodes at the pump bowl

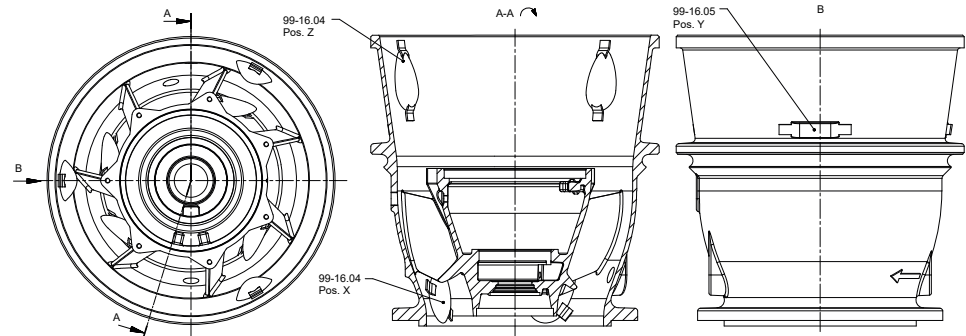

Fig. 63: Sacrificial anodes at the pump bowl

- Information on position X: Distribute the number of sacrificial anodes on both sides of the vanes. The stays for welding on may be shortened.
- Information on position Y: Evenly distribute the number of sacrificial anodes over the circumference. The stays for welding on may be shortened. Rotating the sacrificial anodes is permissible.

Table 42: Combinations of sacrificial anodes at the pump bowl

Size	Quantity and weight at position X	Quantity and weight at position Y	Material of sacrificial anodes
600 - 390	4x0,9 kg	0 kg	Zinc
600 - 420	4x0,9 kg	4x0,25 kg	Zinc
700 - 390	4x0,9 kg	0 kg	Zinc
700 - 420	4x0,9 kg	4x0,25 kg	Zinc
700 - 460	4x0,9 kg	0 kg	Zinc
800 - 460	4x0,9 kg	0 kg	Zinc
800 - 580	6x0,9 kg	4x0,25 kg	Zinc
900 - 630	8x0,9 kg	6x0,25 kg	Zinc
900 - 650	7x0,9 kg	6x0,25 kg	Zinc

- ✓ The pump set is positioned horizontally on a level/even surface and is protected against rolling away.
- ✓ The bellmouth, casing wear ring and impeller have been removed.
 1. Remove sacrificial anodes 99-16.04 and 99-16.05. Clean the surface.
 2. Weld new sacrificial anodes to the lugs. We recommend using new sacrificial anodes made by KSB.

7.9 Tightening torques

Table 43: Tightening torques [Nm] depending on thread, steel grade and property class

Steel grade	A2, A4		A2, A4		C3		1.4410		1.4462			
	8.8		-50		-70		-80		R _{p0,2} ≥ 530 N/mm ²		R _{p0,2} ≥ 450 N/mm ²	
Property class	Min-imum	Nom-inal value	Min-imum	Nom-inal value	Min-imum	Nom-inal value	Min-imum	Nom-inal value	Min-imum	Nom-inal value	Min-imum	Nom-inal value
Thread												
M4	3,0	3,4	1,0	1,1	2,1	2,4	3,0	3,4	2,5	2,8	2,1	2,4
M5	6,1	6,8	2,0	2,2	4,3	4,8	6,1	6,8	5,0	5,6	4,3	4,8
M6	10,3	11	3,4	3,7	7,2	8,0	10	11	8,5	9,5	7,2	8,0
M8	25	28	8,2	9,1	18	19	25	28	21	23	18	19
M10	49	55	16	18	35	38	49	55	41	45	35	38
M12	85	94	28	31	59	66	85	94	70	78	59	66
M14	134	149	44	49	94	105	134	149	111	124	94	105
M16	209	232	69	76	147	163	209	232	173	192	147	163
M20	408	453	134	149	287	319	408	453	338	375	287	319

1581.85/01-EN

Steel grade	8.8		A2, A4		A2, A4		C3		1.4410		1.4462	
Property class	8.8		-50		-70		-80		R _{p0,2} ≥ 530 N/mm ²		R _{p0,2} ≥ 450 N/mm ²	
Thread	Min-imum	Nominal value	Min-imum	Nominal value	Min-imum	Nominal value	Min-imum	Nominal value	Min-imum	Nominal value	Min-imum	Nominal value
M24	704	782	231	257	495	550	704	782	583	648	495	550
M27	1025	1139	36	374	721	801	1025	1139	849	944	721	801
M30	1403	1559	460	511	986	1096	1403	1559	1162	1291	986	1096
M33	1888	2098	619	688	1327	1475	1888	2098	1563	1737	1327	1475
M36	2445	2717	802	891	1719	1910	2445	2717	2025	2250	1719	1910
M42	3904	4338	1281	1423	2745	3050	3904	4338	3233	3592	2745	3050
M48	5880	6534	1929	2144	4135	4594	5880	6534	4870	5411	4135	4594

	NOTE
If using an adjustable torque wrench or torque screwdriver, adjust it to a value within the indicated range between the minimum and the nominal value.	

7.10 Spare parts stock

7.10.1 Ordering spare parts

Always quote the following data when ordering replacement or spare parts:

- Order number
- Order item number
- Type series
- Size
- Year of construction
- Motor number

Refer to the name plate for all data.

Also specify the following data:

- Part No. and description
- Quantity of spare parts
- Shipping address
- Mode of dispatch (freight, mail, express freight, air freight)

7.10.2 Recommended spare parts stock for 2 years' operation to DIN 24296



Table 44: Quantity of spare parts for recommended spare parts stock

Part No.	Description	Number of pumps (including stand-by pumps)						
		2	3	4	5	6	8	10 and more
104-230	Impeller kit	1	1	1	2	2	3	30 %
104-502	Casing wear ring kit	2	2	2	3	3	4	50 %
105-300	Bearing assembly kit	1	1	2	2	3	4	50 %
105-433	Mechanical seal kit	2	3	4	5	6	8	90 %
99-9	Sealing element kit	4	6	8	8	9	10	100 %
1412	O-Ring, discharge tube cover	2	3	4	5	6	8	100 %
1412	O-ring, discharge tube cover, large	2	3	4	5	6	8	100 %
180-1	Motor unit	-	-	-	-	1	2	30 %
182-17	Sensor kit	-	-	-	-	1	2	30 %
1818	Rotor	-	-	-	-	1	2	30 %

1581.85/01-EN

Part No.	Description	Number of pumps (including stand-by pumps)						
		2	3	4	5	6	8	10 and more
1834	Cable gland for power cable	1	1	2	2	2	3	40 %
1834	Cable gland for sensor cable	1	1	2	2	2	3	40 %

8 Trouble-shooting

	 WARNING
	<p>Improper work to remedy faults Risk of injury!</p> <p>▷ For any work performed to remedy faults, observe the relevant information given in this operating manual and/or in the product literature provided by the accessories manufacturer.</p>

If problems occur that are not described in the following table, consultation with the KSB service is required.

- A Pump is running, but does not deliver
- B Pump delivers insufficient flow rate
- C Excessive current/power input
- D Insufficient discharge head
- E Vibrations and noise during pump operation

Table 45: Trouble-shooting

A	B	C	D	E	Possible causes	Remedy ¹¹⁾
-	X	-	-	X	Water level lowered too much during operation	Check supply and capacity of system (sump floor area). Check level control equipment.
X	X	-	-	X	Total pressure corresponding to $NPSH_{pump}$ too high Total pressure corresponding to $NPSH_{system}$ too low	Increase fluid level on the suction side. Clean screening equipment, if required.
X	X	X	-	X	Penetration of air into the pump due to formation of an air pocket - Suction-side water level too low	Increase the suction-side water level. If this is not possible or unsuccessful, please contact KSB.
X	X	X	-	X	Unfavourable flow to the pump inlet	Improve the flow to the intake chamber (contact KSB).
-	X	X	-	X	Pump running in off-design conditions - part load/overload	Check the pump's operating data.
X	X	-	X	X	Pump clogged by deposits	Clean intake and pump components.
-	X	X	X	X	Wear	Replace worn components by new ones.
-	X	-	X	X	Impermissible air or gas content in the fluid handled	Contact KSB.
-	-	-	-	X	System-induced vibrations	Contact KSB.
-	-	X	-	X	Wrong direction of rotation	Check the electrical connection of motor and control system, if any.
X	-	-	-	-	No voltage	Check electrical connections. Contact the energy supplier.
X	-	-	-	-	Motor winding or electric cable are defective.	Replace with original KSB cable or contact KSB.
-	-	X	-	X	Worn or defective rolling element bearings	Contact KSB.
X	-	-	-	-	The thermistor tripping unit with manual reset for temperature limiter has tripped the pump as a result of the permissible winding temperature being exceeded.	Have cause determined and eliminated by qualified and trained personnel.
X	-	-	-	-	Motor has been tripped by leakage monitor.	Have cause determined and eliminated by qualified and trained personnel.

1581.85/01-EN

¹¹ The pump pressure must be released before attempting to remedy faults on parts which are subjected to pressure. Disconnect the pump set from the power supply!

A	B	C	D	E	Possible causes	Remedy ¹¹⁾
X	-	-	-	-	Mechanical seal monitor has tripped.	Have cause determined and eliminated by qualified and trained personnel.
X	-	-	-	-	Bearing temperature monitor has tripped.	Have cause determined and eliminated by qualified and trained personnel.

9 Related Documents

9.1 General assembly drawing with list of components

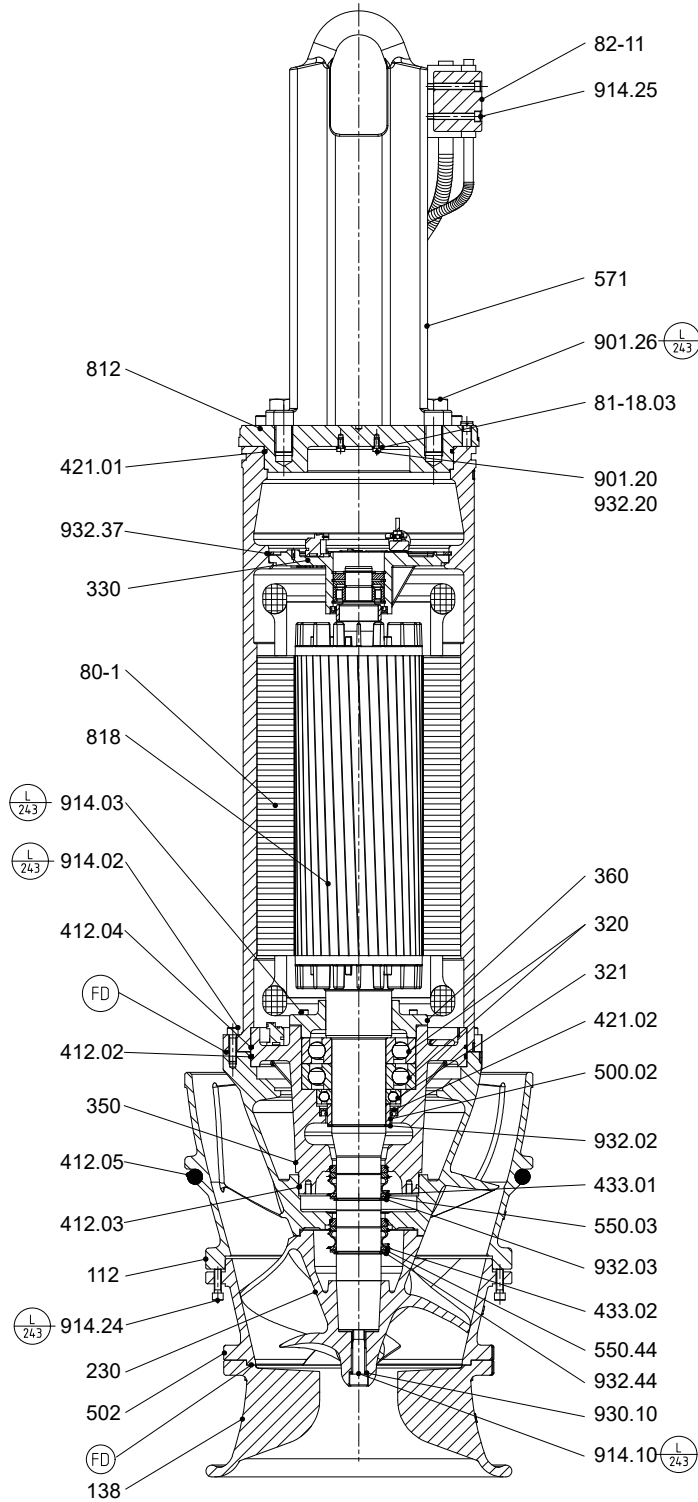

Fig. 64: General assembly drawing

Table 46: Symbols key



Symbol	Description
	Always apply a liquid sealant (e.g. Hylomar SQ32M) to sealing surfaces marked with this symbol.
	Always secure screwed connections marked with this symbol with Loctite 243 .

Table 47: List of components

Part No.	Description	Part No.	Description
112	Pump bowl	502	Casing wear ring
138	Bellmouth	550.03/.44	Disc
230	Impeller	571	Bail
320	Rolling element bearing	80-1	Motor unit
321	Radial ball bearing	81-18.03	Cable terminal
330	Bearing bracket	812	Motor housing cover
350	Bearing housing	818	Rotor
360	Bearing cover	901.20/.26	Hexagon head bolt
412.02/.03/.04/.05	O-ring	914.02/.03/.10/.24	Hexagon socket head cap screw
421.01/.02	Lip seal	930.10	Safety device
433.01/.02	Mechanical seal	932.02/.03/.20/.37/.44	Circlip
500.02	Ring		

9.2 Detail drawings

9.2.1 Cable gland and fastening

Cable gland and fastening, motors: 70 4 215 4, 47 6 205 6, 40 8 160 8

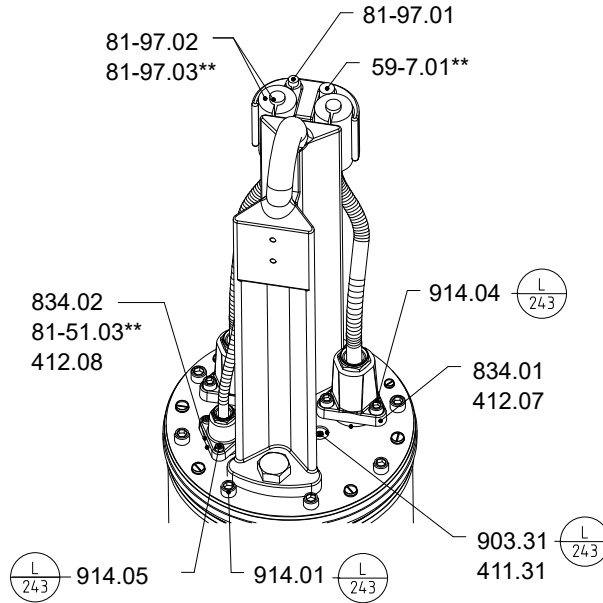

Fig. 65: Cable gland and fastening, motors: 70 4 215 4, 47 6 205 6, 40 8 160 8

Table 48: Symbols key

Symbol	Description
	Always secure screwed connections marked with this symbol with Loctite 243 .

Table 49: List of components

Part No.	Description	Part No.	Description
411.31	Joint ring	81-97.01/.02/.03	Cable protector
412.07/.08	O-ring	834.01/.02	Cable gland
59-7.01	Support	903.31	Screw plug
81-51.03	Clamping element ¹²⁾	914.01/.04/.05	Hexagon head bolt

¹²⁾ Only fitted on pump set with sensor system.

Cable gland and fastening, motors: 275 4 300 4, 250 6 340 6, 205 8 290 8

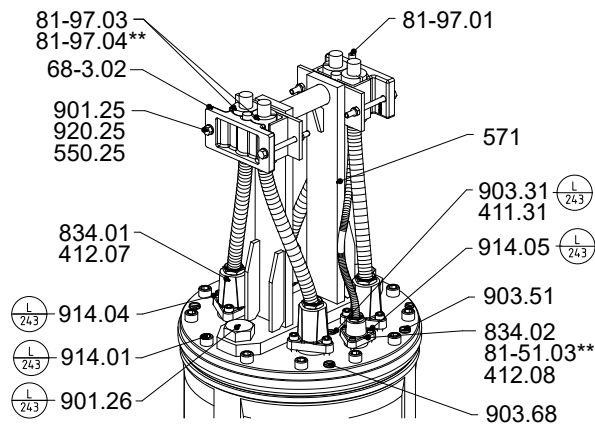

Fig. 66: Cable gland and fastening, motors: 275 4 300 4, 250 6 340 6, 205 8 290 8

Table 50: Symbols key

Symbol	Description
	Always secure screwed connections marked with this symbol with Loctite 243 .

Table 51: List of components

Part No.	Description	Part No.	Description
411.31	Joint ring	81-97.01/.03/.04	Cable protector
412.07/.08	O-ring	834.01/.02	Cable gland
550.25	Disc	901.25/.26	Hexagon head bolt
571	Bail	903.31/.51/.68	Screw plug
68-3.02	Cover plate	914.01/.04/.05	Hexagon head bolt
81-51.03	Clamping element	920.25	Nut

9.2.2 Bearing temperature sensors

Bearing temperature sensor, motor end, sensor package Basic+ or Premium

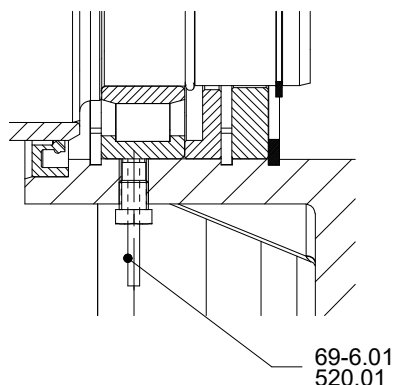

Fig. 67: Bearing temperature sensor, motor end

Table 52: List of components

Part No.	Description	Part No.	Description
520.01	Sleeve	69-6.01	Temperature sensor

Bearing temperature sensor, pump end

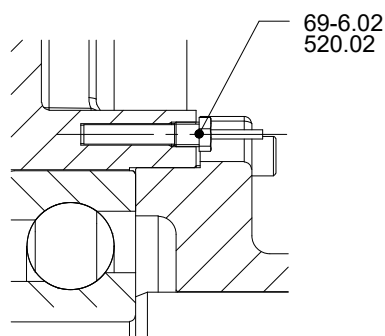

Fig. 68: Bearing temperature sensor, pump end

Table 53: List of components

Part No.	Description	Part No.	Description
520.02	Sleeve	69-6.02	Temperature sensor

9.2.3 Bearings

Bearing, motor end

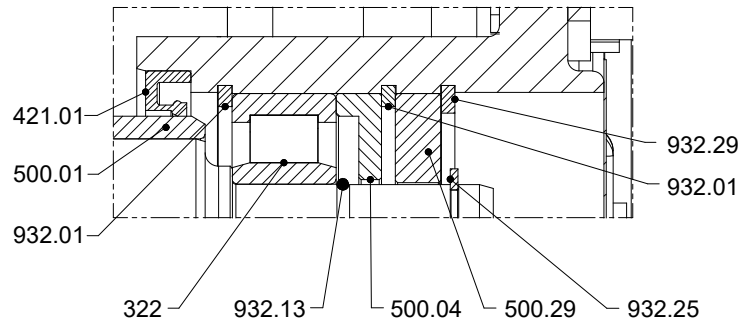

Fig. 69: Bearing, motor end

Table 54: List of components

Part No.	Description	Part No.	Description
322	Radial roller bearing	500.01/04/29	Ring
421.01	Lip seal	932.01/13/25/29	Circlip

Bearing, pump end, motors: 70 4 ... 215 4, 47 6 ... 205 6 and 40 8 ... 160 8

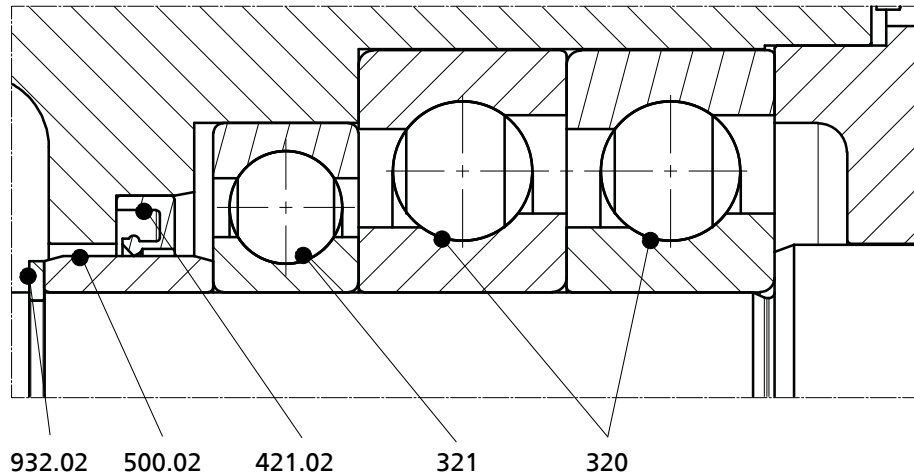

Fig. 70: Bearing, pump end, motors: 70 4 ... 215 4, 47 6 ... 205 6 and 40 8 ... 160 8

Table 55: List of components

Part No.	Description	Part No.	Description
320	Rolling element bearing	500.02	Ring
321	Radial ball bearing	932.02	Circlip
421.02	Lip seal		

Bearing, pump end, motors: 275 4 ... 300 4, 250 6 ... 340 6 and 205 8 ... 290 8

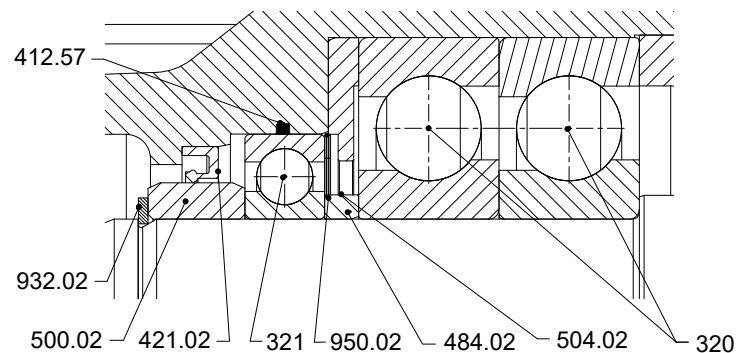

Fig. 71: Bearing, pump end, motors: 275 4 ... 300 4, 250 6 ... 340 6 and 205 8 ... 290 8

Table 56: List of components

Part No.	Description	Part No.	Description
320	Rolling element bearing	500.02	Ring
321	Radial ball bearing	504.02	Spacer ring
412.57	O-ring	932.02	Circlip
421.02	Lip seal	950.02	Spring
484.02	Spring plate		

9.2.4 Sensors, bearing housing

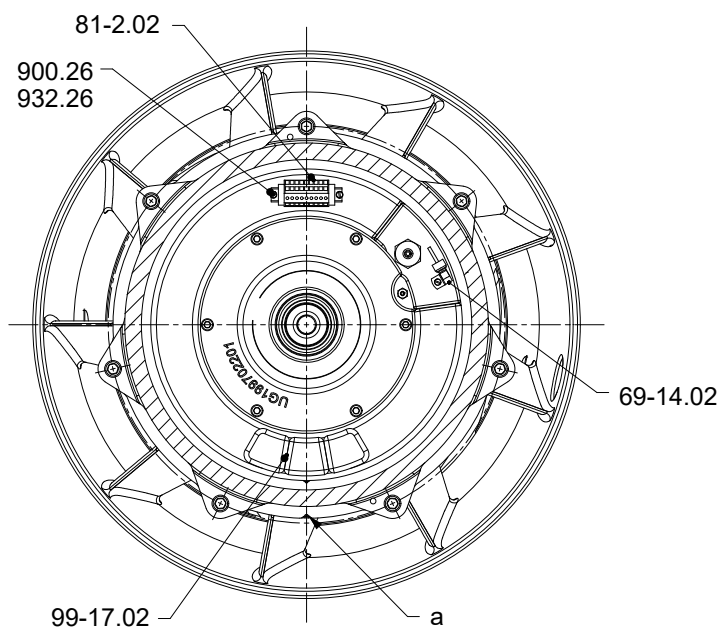

Fig. 72: Sensors, bearing housing
a = alignment groove

Table 57: List of components

Part No.	Description	Part No.	Description
69-14.02	Leakage sensor	900.26	Bolt/screw
81-2.02	Plug	932.26	Circlip
99-17.02	Desiccant		

9.2.5 Sensors/terminals, bearing bracket

Sensors/terminals, bearing bracket, motors: 70 4 215 4, 47 6 205 6 and 40 8 160 8, pump set with standard sensors

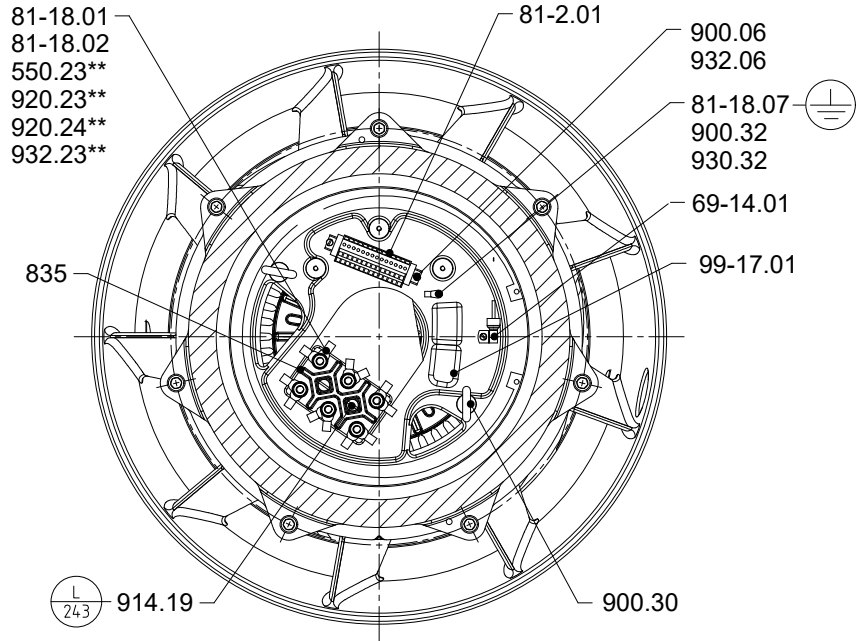

Fig. 73: Sensors/terminals, bearing bracket, motors: 70 4 215 4, 47 6 205 6 and 40 8 160 8, pump set with standard sensors
 ** Only fitted on specific sizes.

Table 58: Symbols key

Symbol	Description
	Always secure screwed connections marked with this symbol with Loc-tite 243 .

Table 59: List of components

Part No.	Description	Part No.	Description
550.23	Disc	900.06/.30/.32	Bolt/screw
69-14.01	Leakage sensor	914.19	Hexagon socket head cap screw
81-2.01	Plug	920.23/.24	Nut
81-18.01/.02/.07	Cable terminal	930.32	Safety device
835	Terminal board	932.06/.23	Circlip
99-17.01	Desiccant		

Sensors/terminals, bearing bracket, motors: 70 4 215 4, 47 6 205 6 and 40 8 160 8, pump set with sensor system

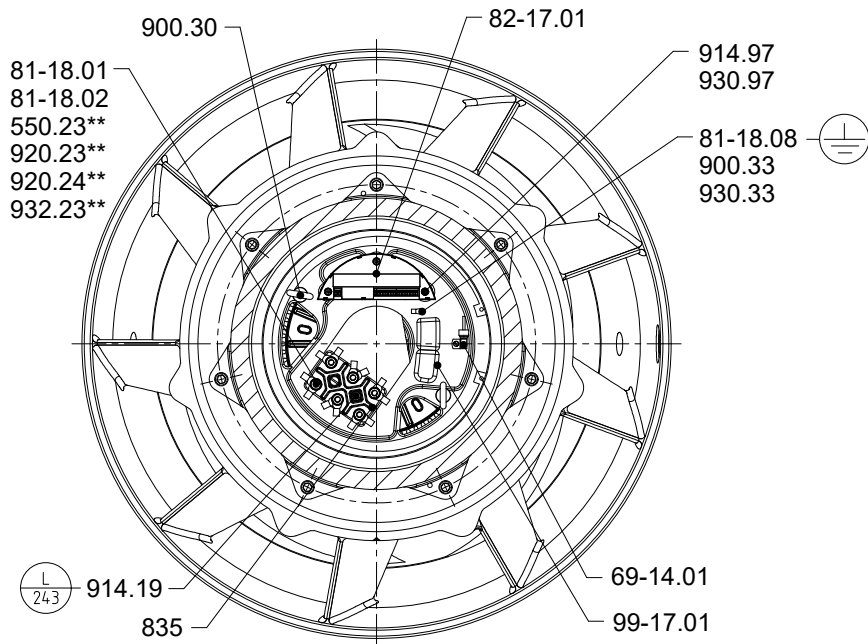

Fig. 74: Sensors/terminals, bearing bracket, motors: 70 4 215 4, 47 6 205 6 and 40 8 160 8, pump set with sensor system

** Only fitted on specific sizes.

Table 60: Symbols key

Symbol	Description
	Always secure screwed connections marked with this symbol with Loctite 243 .

Table 61: List of components

Part No.	Description	Part No.	Description
550.23	Disc	900.30/.33	Bolt/screw
69-14.01	Leakage sensor	914.19/.97	Hexagon socket head cap screw
81-18.01/.02/.08	Cable terminal	920.23/.24	Nut
82-17.01	Integrated electronic system	930.33/.97	Safety device
835	Terminal board	932.23	Circlip
99-17.01	Desiccant		

Sensors/terminals, bearing bracket, motors: 275 4 300 4, 250 6 340 6 and 205 8 290 8, pump set with standard sensors

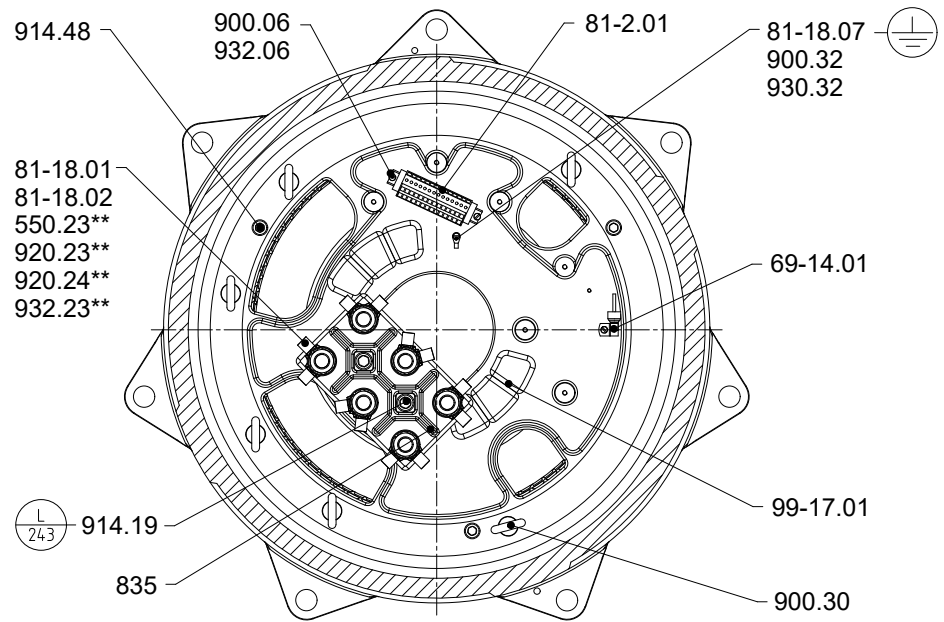

Fig. 75: Sensors/terminals, bearing bracket, motors: 275 4 300 4, 250 6 340 6 and 205 8 290 8, pump set with standard sensors

** Only fitted on specific sizes.

Table 62: Symbols key

Symbol	Description
	Always secure screwed connections marked with this symbol with Loctite 243 .

Table 63: List of components

Part No.	Description	Part No.	Description
550.23	Disc	914.19/.48	Hexagon socket head cap screw
69-14.01	Leakage sensor	900.06/.30/.32	Bolt/screw
81-2.01	Plug	920.23/.24	Nut
81-18.01/.02/.07	Cable terminal	930.32	Safety device
835	Terminal board	932.06/.23	Circlip
99-17.01	Desiccant		

Sensors/terminals, bearing bracket, motors: 275 4 300 4, 250 6 340 6 and 205 8 290 8, pump set with sensor system

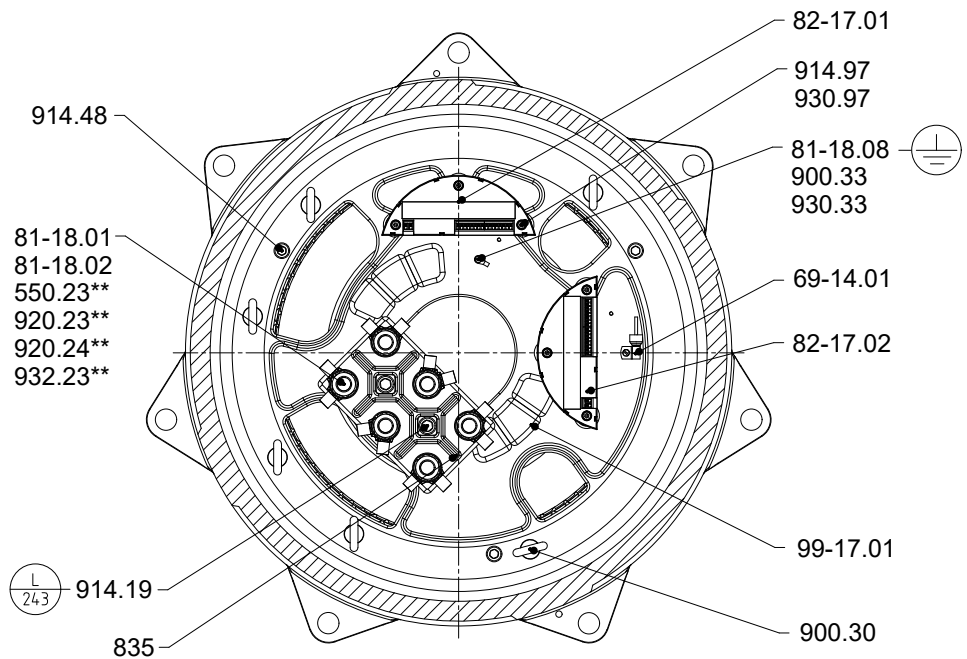

Fig. 76: Sensors/terminals, bearing bracket, motors: 275 4 300 4, 250 6 340 6 and 205 8 290 8, pump set with sensor system

** Only fitted on specific sizes.

Table 64: Symbols key

Symbol	Description
\textcircled{L} 243	Always secure screwed connections marked with this symbol with Loctite 243 .

Table 65: List of components

Part No.	Description	Part No.	Description
550.23	Disc	900.30/33	Bolt/screw
69-14.01	Leakage sensor	914.19/48/97	Hexagon socket head cap screw
81-18.01/02/08	Cable terminal	920.23/24	Nut
82-17.01/02	Integrated electronic system	930.33/97	Safety device
835	Terminal board	932.23	Circlip
99-17.01	Desiccant		

9.2.6 Bearing bracket fastening

Bearing bracket fastening, motors: 70 4 215 4, 47 6 205 6 and 40 8 160 8

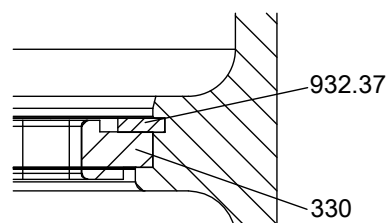

Fig. 77: Bearing bracket fastening, motors: 70 4 215 4, 47 6 205 6 and 40 8 160 8

Table 66: List of components

Part No.	Description	Part No.	Description
330	Bearing bracket	932.37	Circlip

Bearing bracket fastening, motors: 275 4 300 4, 250 6 340 6 and 205 8 290 8

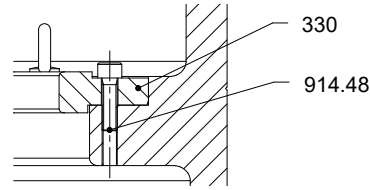

Fig. 78: Bearing bracket fastening, motors: 275 4 300 4, 250 6 340 6 and 205 8 290 8

Table 67: List of components

Part No.	Description	Part No.	Description
330	Bearing bracket	914.48	Hexagon socket head cap screw

9.2.7 Screwed connection bellmouth/casing wear ring/pump bowl

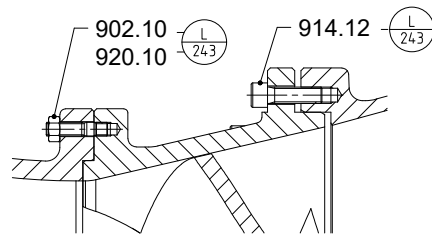

Fig. 79: Screwed connection bellmouth/casing wear ring/pump bowl

Table 68: Symbols key

Symbol	Description
	Always secure screwed connections marked with this symbol with Loctite 243 .

Table 69: List of components

Part No.	Description	Part No.	Description
902.10	Stud	920.10	Nut
914.12	Hexagon socket head cap screw		

9.2.8 Clearance adjusting screw

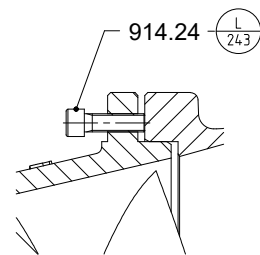

Fig. 80: Clearance adjusting screw

Table 70: Symbols key

Symbol	Description
	Always secure screwed connections marked with this symbol with Loctite 243 .

Table 71: List of components

Part No.	Description	Part No.	Description
914.24	Hexagon socket head cap screw		

1581.85/01-EN

9.2.9 Impeller fastening elements, tapered connection

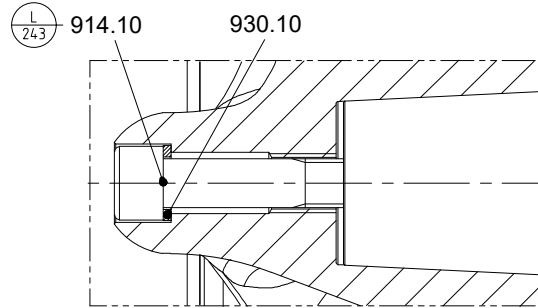

Fig. 81: Impeller fastening elements, tapered connection

Table 72: Symbols key

Symbol	Description
	Always secure screwed connections marked with this symbol with Loctite 243 .

Table 73: List of components

Part No.	Description	Part No.	Description
914.10	Hexagon socket head cap screw	930.10	Safety device

9.2.10 Impeller fastening elements, cylindrical connection

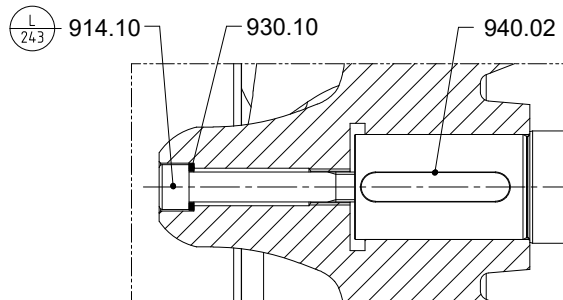

Fig. 82: Impeller fastening elements, cylindrical connection

Table 74: Symbols key

Symbol	Description
	Always secure screwed connections marked with this symbol with Loctite 243 .

Table 75: List of components

Part No.	Description	Part No.	Description
914.10	Hexagon socket head cap screw	920.02	Nut
930.10	Safety device		

9.2.11 Grub screw in the impeller

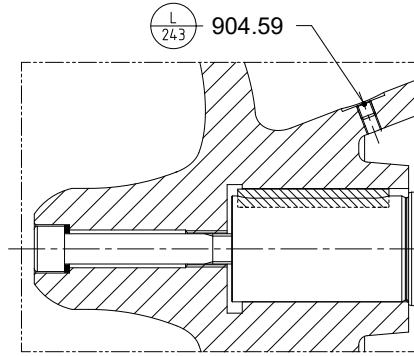

Fig. 83: Grub screw 904.59 ¹³⁾ in the impeller

Table 76: Symbols key

Symbol	Description
	Always secure screwed connections marked with this symbol with Loctite 243 .

Table 77: List of components

Part No.	Description	Part No.	Description
904.59	Grub screw	-	-

9.2.12 Mechanical seal with covered spring

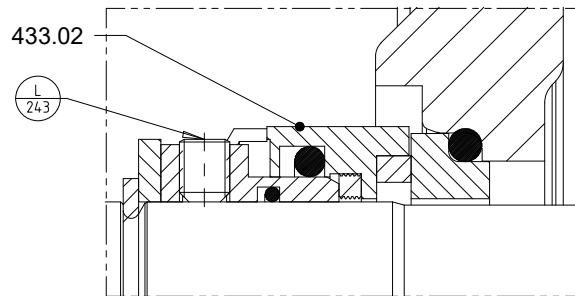

Fig. 84: Mechanical seal with covered spring

Table 78: Symbols key

Symbol	Description
	Always secure screwed connections marked with this symbol with Loctite 243 .

Table 79: List of components

Part No.	Description	Part No.	Description
433.02	Mechanical seal		

1581.85/01-EN

¹³⁾ Does not apply to sizes 600-390, 700-390, 600-420 and 700-420.

9.2.13 Float switch

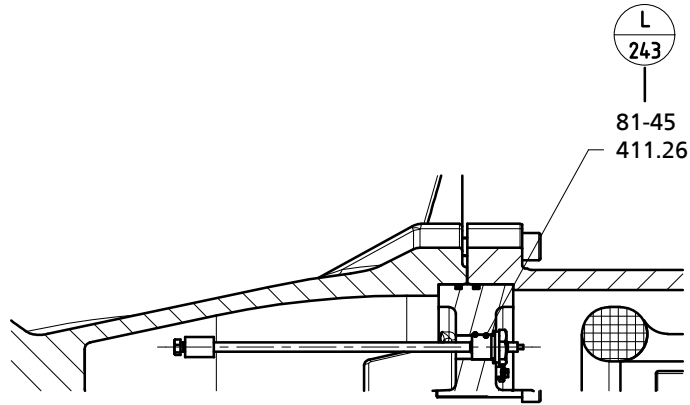

Fig. 85: Float switch

Table 80: Symbols key

Symbol	Description
	Always secure screwed connections marked with this symbol with Loctite 243 .

Table 81: List of components

Part No.	Description	Part No.	Description
411.26	Joint ring	81-45	Float switch

9.2.14 Lubricant inlet

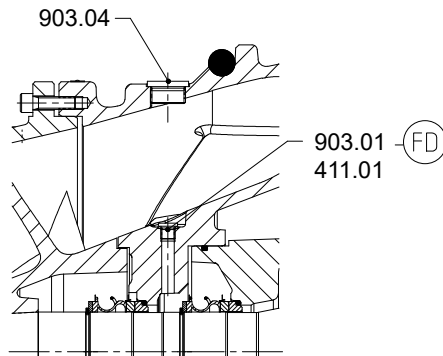

Fig. 86: Lubricant inlet

Table 82: Symbols key

Symbol	Description
	Always apply a liquid sealant (e.g. Hylomar SQ32M) to sealing surfaces marked with this symbol.

Table 83: List of components

Part No.	Description	Part No.	Description
411.01	Joint ring	903.01/04	Screw plug

9.2.15 Lubricant drain / leakage chamber

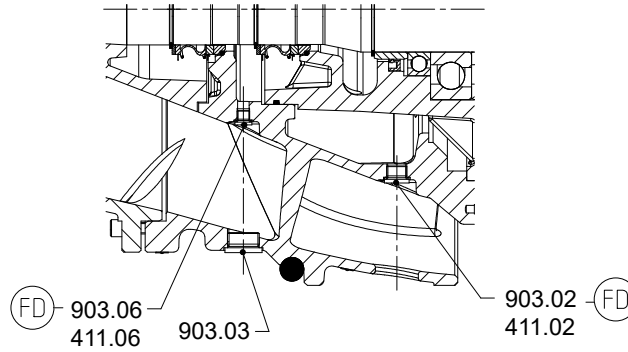

Fig. 87: Lubricant drain / leakage chamber

Table 84: Symbols key

Symbol	Description
(FD)	Always apply a liquid sealant (e.g. Hylomar SQ32M) to sealing surfaces marked with this symbol.

Table 85: List of components

Part No.	Description	Part No.	Description
411.02/06	Joint ring	903.02/03/06	Screw plug

9.2.16 Labels/plates

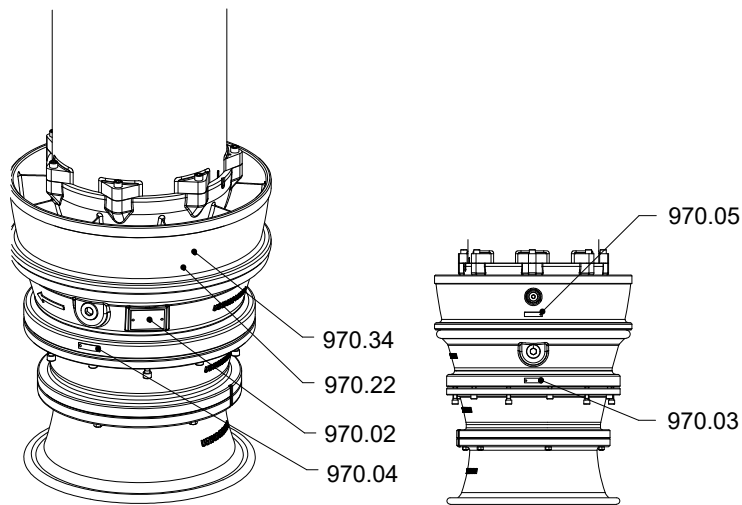

Fig. 88: Labels/plates

Table 86: List of components

Part No.	Description	Part No.	Description
970.02	Label/plate: name plate	970.05	Label/plate: leakage drain
970.03	Label/plate: lubricant drain	970.22	Label/plate: warning sign
970.04	Label/plate: lubricant filler plug	970.34	Label/plate:

1581.85/01-EN

9.2.17 Version with adapter

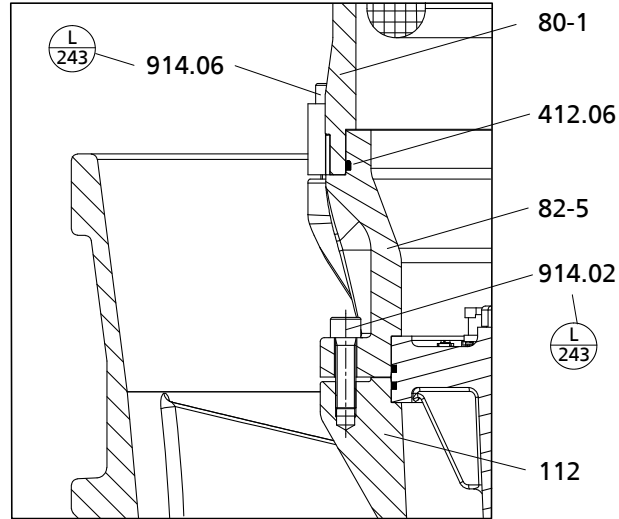

Fig. 89: Version with adapter

Table 87: Symbols key

Symbol	Description
	Always secure screwed connections marked with this symbol with Loctite 243 .

Table 88: List of components

Part No.	Description	Part No.	Description
112	Pump bowl	82-5	Adapter
412.06	O-ring	914.02/.06	Hexagon socket head cap screw
80-1	Motor unit		

9.3 Cable bundle

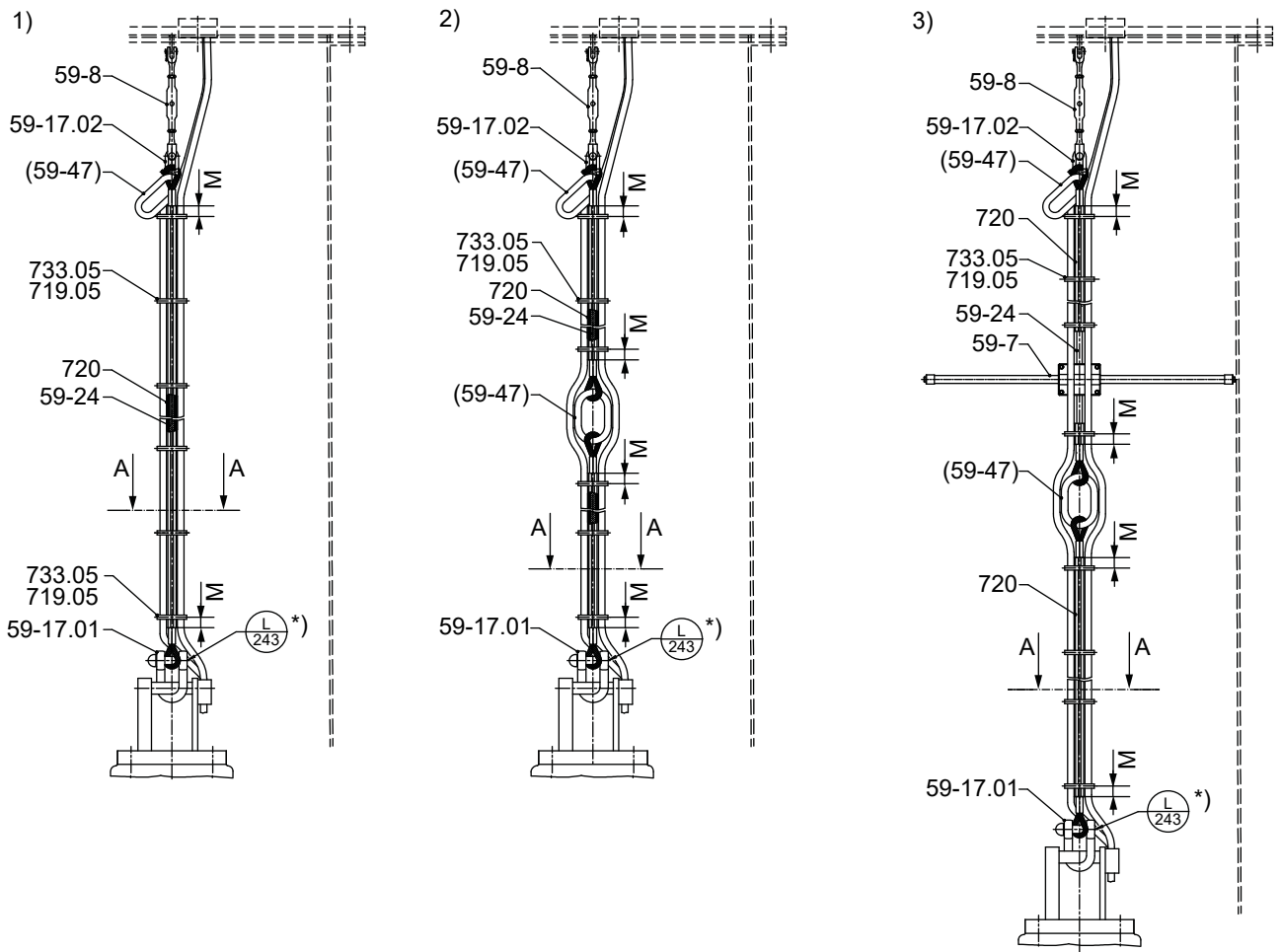

Fig. 90: Cable bundle

1)	Basic design
2)	Design with lifting lug
3)	Design with support

*) : Only required for galvanised version

	NOTE
	Distance M = 50 mm

Table 89: Symbols key

Symbol	Description
	Always secure screwed connections marked with this symbol with Loc-tite 243 .

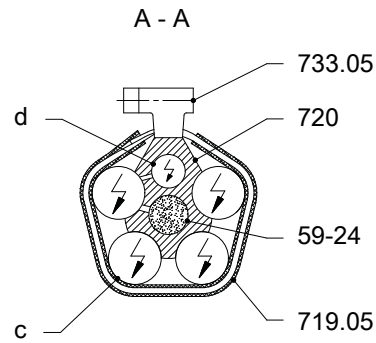

Fig. 91: Section A - A, position of power cable, control cable and support rope

c	Power cable	d	Control cable
---	-------------	---	---------------

Table 90: List of spare parts of the cable bundle

Part No.	Description	Part No.	Description
59-7	Support	59-47	Lifting lug
59-8	Turnbuckle	719.05	Flexible tube
59-17.01/.02	Shackle	720	Fitting
59-24	Rope / support rope	733.05	Hose clip

9.4 Wiring diagrams

9.4.1 Wiring diagram for the power cable

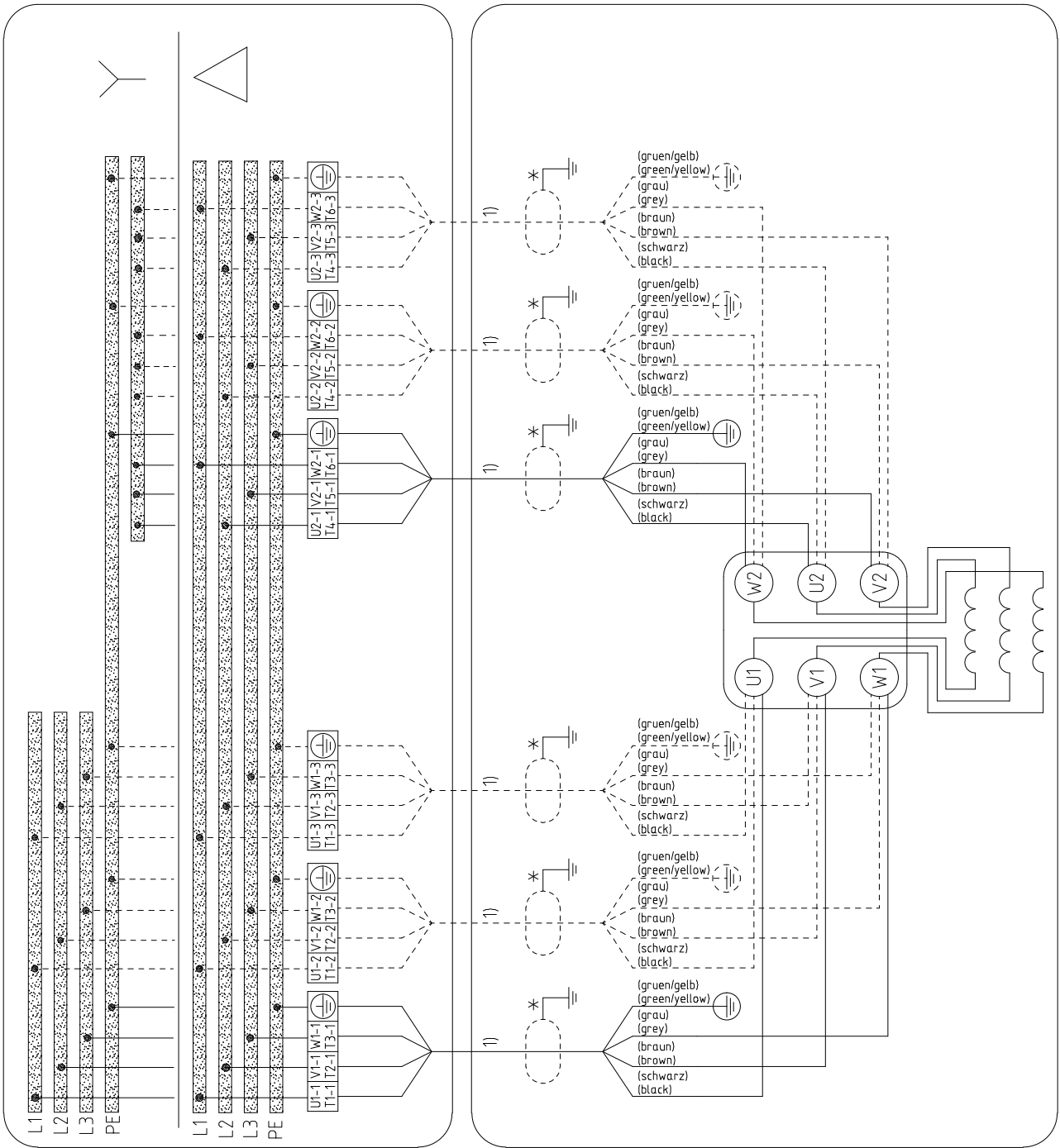

UG1417433

Fig. 92: Wiring diagram for the power cable

1)	Up to 3 parallel cable pairs possible
*	Shielded cable optional

9.4.2 Wiring diagrams for the sensors

9.4.2.1 Pump set with standard sensors

Motor sizes:
 70 4 ... 300 4
 47 6 ... 340 6
 40 8 ... 290 8

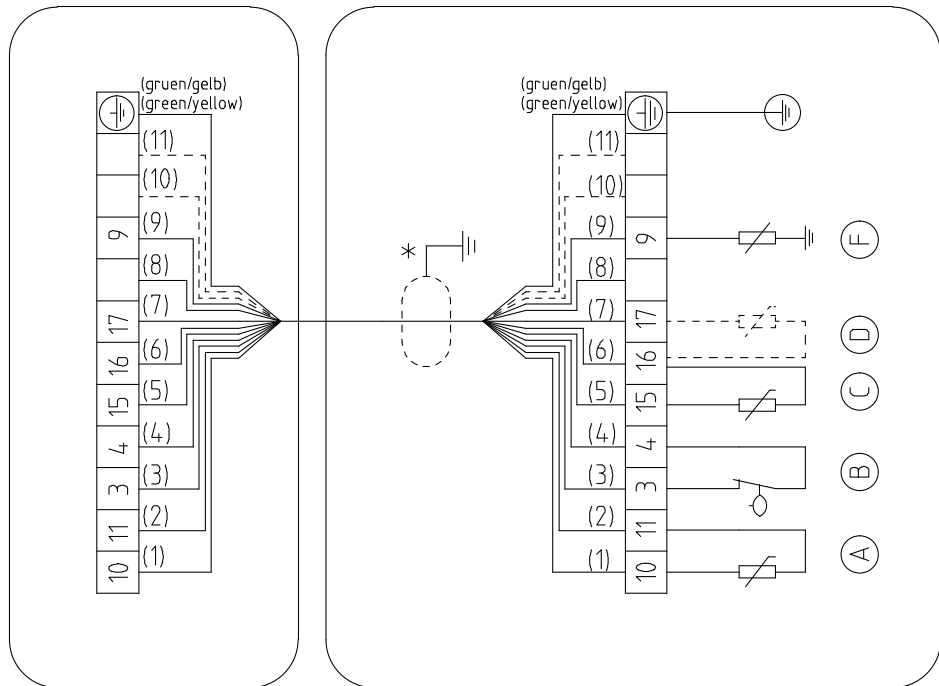

UG1415401

Fig. 93: Wiring diagram: pump set with standard sensors

*	Shielded cable option
(A)	Motor temperature (PTC)
(B)	Mechanical seal leakage
(C)	Bearing temperature (pump-end bearing)
(D)	Bearing temperature (motor-end bearing) optional
(E)	Leakage inside the motor

9.4.2.2 Pump set with sensor system

Motor sizes:
 70 4 ... 215 4
 47 6 ... 205 6
 55 8 ... 160 8

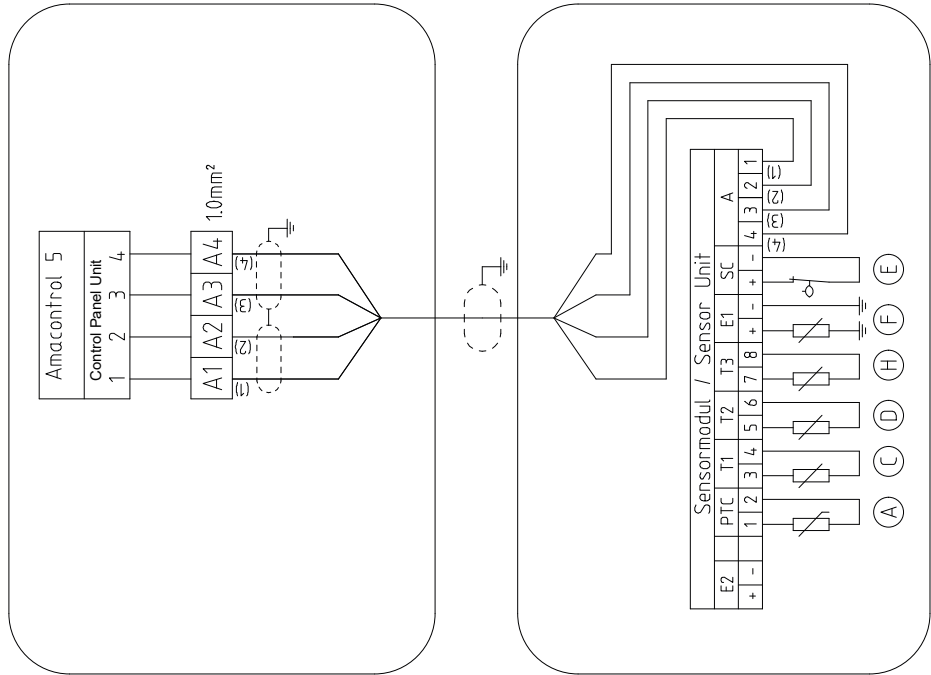

UG2048584

Fig. 94: Wiring diagram: pump set with sensor system with one sensor module

Ⓐ	Motor temperature (PTC)
Ⓒ	Bearing temperature (pump-end bearing)
Ⓓ	Bearing temperature (motor-end bearing)
Ⓔ	Mechanical seal leakage
Ⓕ	Leakage inside the motor
Ⓖ	Motor temperature (Pt100)

Motor sizes:
from 275 4
from 250 6
from 205 8

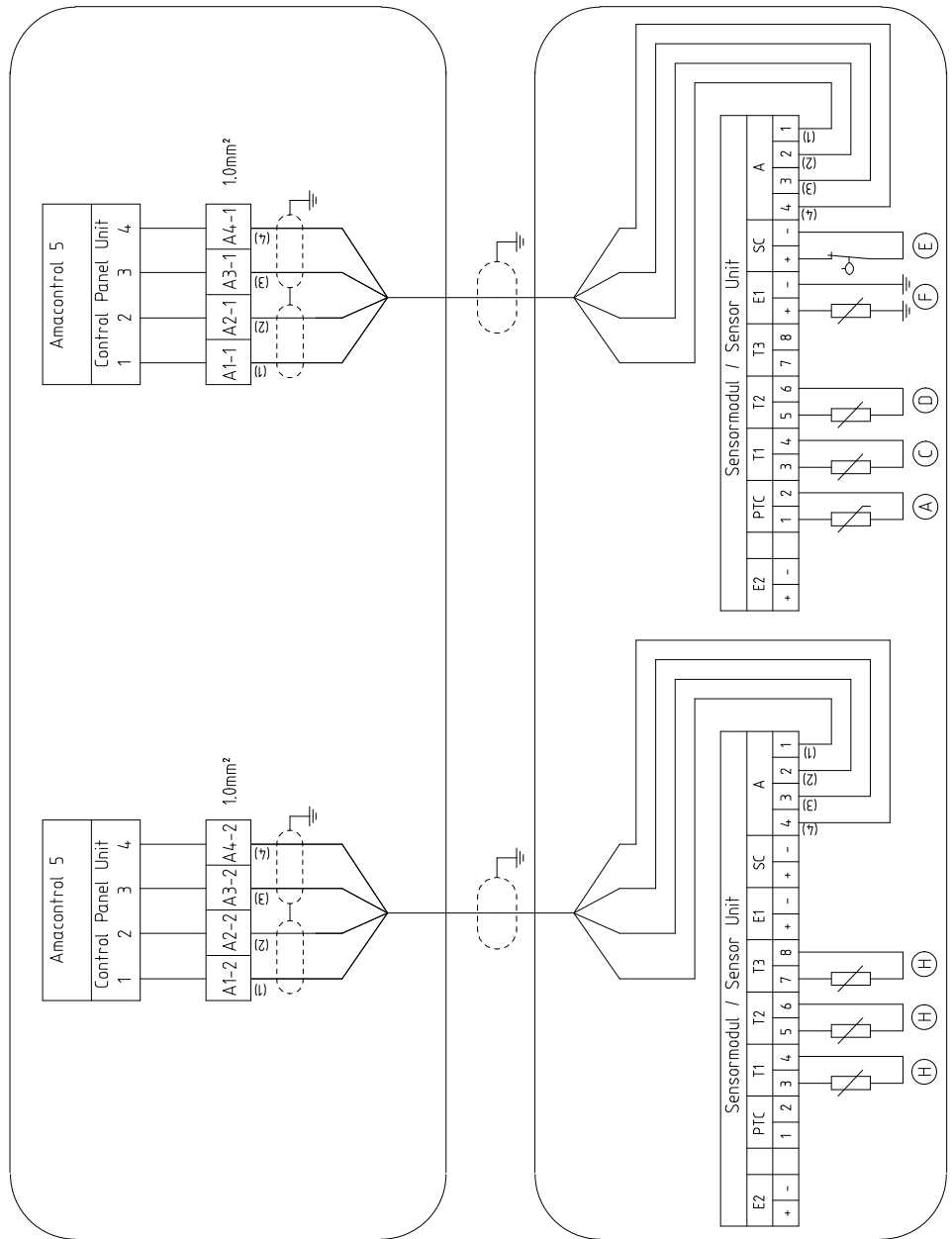

UG2048618

Fig. 95: Wiring diagram: pump set with sensor system with two sensor modules

(A)	Motor temperature (PTC)
(C)	Bearing temperature (pump-end bearing)
(D)	Bearing temperature (motor-end bearing)
(E)	Mechanical seal leakage
(F)	Leakage inside the motor
(H)	Motor temperature (Pt100)

9.5 Flamepaths on explosion-proof motors

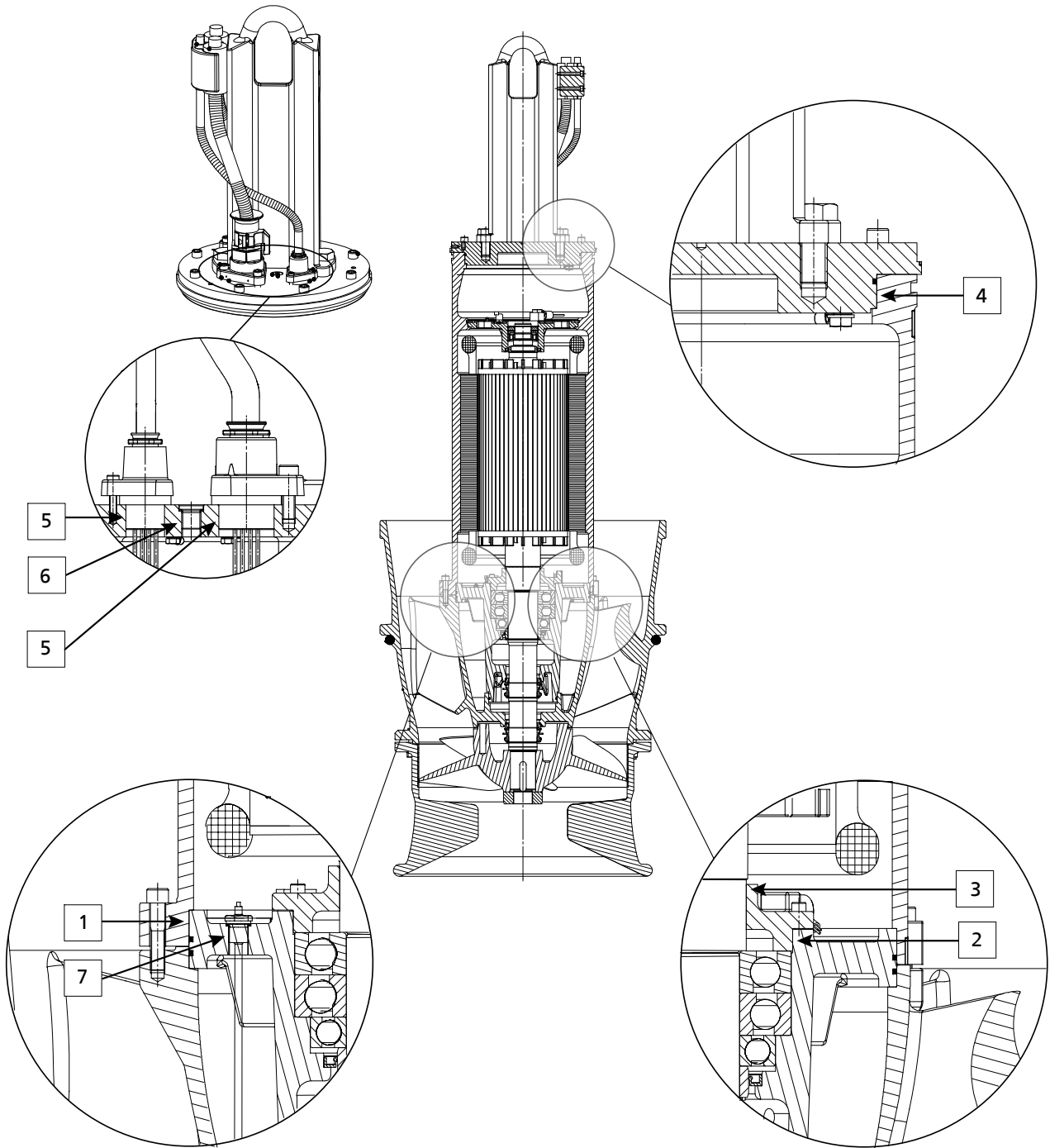

Fig. 96: Flamepaths, pump set

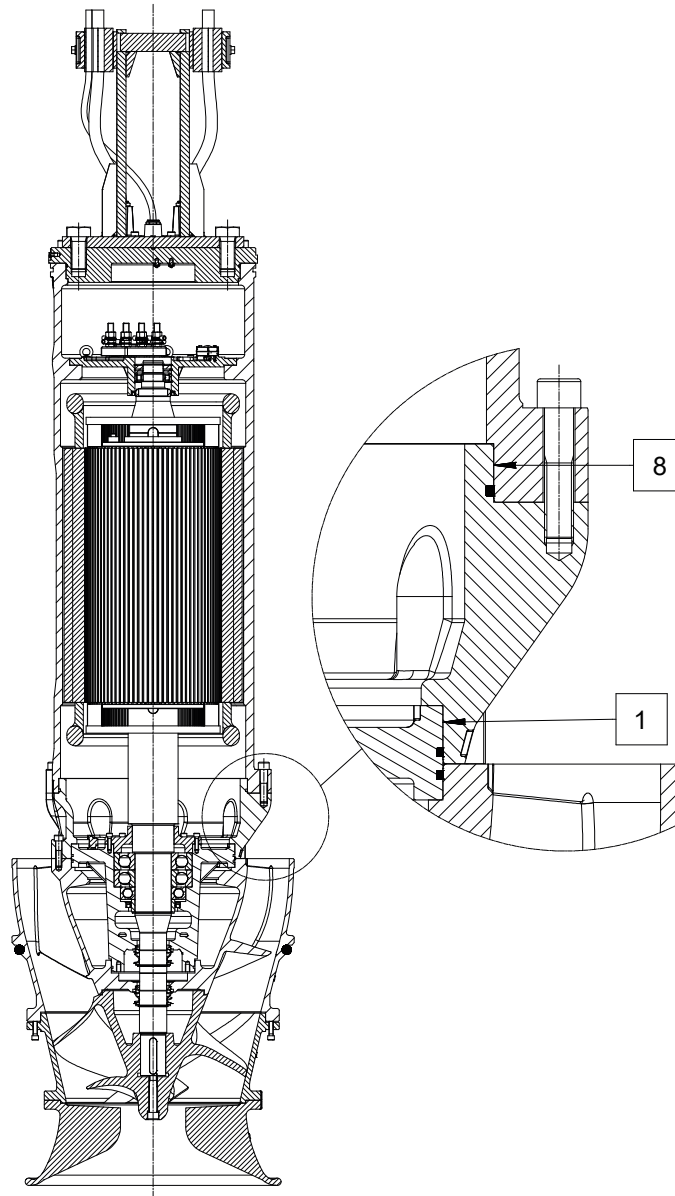

Fig. 97: Flamepaths, adapter

9.6 Dimensions

9.6.1 Dimensions [mm]

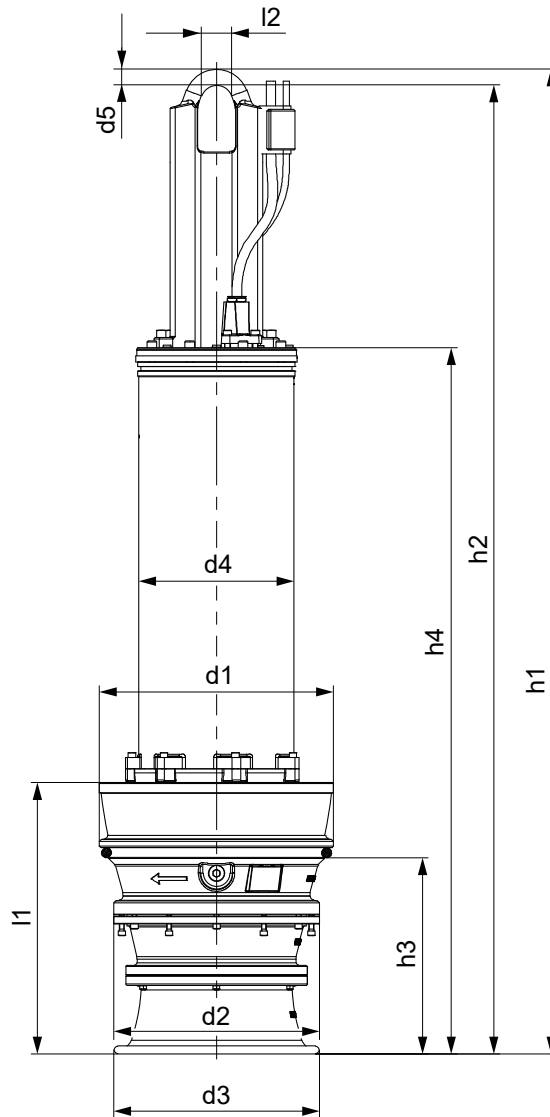

Fig. 98: Pump set dimensions

Table 91: Pump set dimensions [mm]

Size	Motor size	Number of poles	d_1	d_2	d_3	d_4	d_5	h_1	h_2	h_3	h_4	l_1	l_2	[kg] ¹⁴⁾
600-390	70	4	582	500	530	385	40	2279	2239	517	1588	722	80	945
600-390	80	4	582	500	530	385	40	2279	2239	517	1588	722	80	970
600-390	90	4	582	500	530	385	40	2479	2439	517	1788	722	80	1070
600-390	105	4	582	500	530	385	40	2479	2439	517	1788	722	80	1110
600-390	130	4	582	500	530	385	40	2479	2439	517	1788	722	80	1150
600-390	47	6	582	500	530	385	40	2279	2239	517	1588	722	80	945
600-390	65	6	582	500	530	385	40	2279	2239	517	1588	722	80	960
600-390	80	6	582	500	530	385	40	2479	2439	517	1788	722	80	1060

¹⁴⁾ Pump set in material variant G3, with 10-metre power cable and 5-metre support rope. The indicated weights are reference values only. Refer to the data sheet for the exact weight.

Size	Motor size	Number of poles	d ₁	d ₂	d ₃	d ₄	d ₅	h ₁	h ₂	h ₃	h ₄	l ₁	l ₂	[kg] ¹⁴⁾
700-390	170	4	582	500	530	475	40	2800	2760	517	2109	722	80	1555
700-390	190	4	582	500	530	475	40	2800	2760	517	2109	722	80	1605
600-420	70	4	580	510	510	385	40	2243	2203	486	1552	673	80	905
600-420	90	4	580	510	510	385	40	2443	2403	486	1752	673	80	1045
600-420	105	4	580	510	510	385	40	2443	2403	486	1752	673	80	1085
600-420	130	4	580	510	510	385	40	2443	2403	486	1752	673	80	1125
700-420	170	4	580	510	510	475	40	2764	2724	486	2073	673	80	1530
700-420	190	4	580	510	510	475	40	2764	2724	486	2073	673	80	1580
700-420	215	4	580	510	510	475	40	2764	2724	486	2073	673	80	1610
700-460	90	4	678	580	610	385	40	2550	2510	553	1859	807	80	1130
700-460	105	4	678	580	610	385	40	2550	2510	553	1859	807	80	1175
700-460	130	4	678	580	610	385	40	2550	2510	553	1859	807	80	1215
700-460	150	4	678	580	610	475	40	2724	2684	553	2033	807	80	1625
700-460	170	4	678	580	610	475	40	2724	2684	553	2033	807	80	1625
700-460	190	4	678	580	610	475	40	2724	2684	553	2033	807	80	1670
700-460	215	4	678	580	610	475	40	2724	2684	553	2033	807	80	1700
700-460	47	6	678	580	610	385	40	2350	2310	553	1659	807	80	1020
700-460	60	6	678	580	610	385	40	2350	2310	553	1659	807	80	1020
700-460	80	6	678	580	610	385	40	2550	2510	553	1859	807	80	1145
700-460	100	6	678	580	610	385	40	2550	2510	553	1859	807	80	1190
700-460	120	6	678	580	610	385	40	2550	2510	553	1859	807	80	1235
700-460	155	6	678	580	610	475	40	2724	2684	553	2033	807	80	1605
800-460	275	4	678	580	610	555	50	3130	3071	553	2531	807	90	2310
800-460	300	4	678	580	610	555	50	3130	3071	553	2531	807	90	2375
800-580	80	6	778	695	705	385	40	2603	2563	636	1912	900	80	1335
800-580	100	6	778	695	705	385	40	2603	2563	636	1912	900	80	1380
800-580	120	6	778	695	705	385	40	2603	2563	636	1912	900	80	1425
800-580	155	6	778	695	705	475	40	2777	2737	636	2086	900	80	1795
800-580	180	6	778	695	705	475	40	2777	2737	636	2086	900	80	1825
800-580	205	6	778	695	705	475	40	2777	2737	636	2086	900	80	1880
800-580	250	6	778	695	705	555	50	3184	3124	636	2584	900	90	2530
800-580	290	6	778	695	705	555	50	3184	3124	636	2584	900	90	2670
800-580	340	6	778	695	705	555	50	3184	3124	636	2584	900	90	2800
900-630	155	6	876	790	790	475	40	2928	2888	593	2237	1085	80	2110
900-630	180	6	876	790	790	475	40	2928	2888	593	2237	1085	80	2140
900-630	205	6	876	790	790	475	40	2928	2888	593	2237	1085	80	2195
900-630	250	6	876	790	790	555	50	3188	3129	593	2589	1085	90	2835
900-630	290	6	876	790	790	555	50	3188	3129	593	2589	1085	90	2975
900-630	340	6	876	790	790	555	50	3188	3129	593	2589	1085	90	3105
900-650	155	6	876	760	770	475	40	2872	2832	680	2181	1028	80	2015
900-650	180	6	876	760	770	475	40	2872	2832	680	2181	1028	80	2040
900-650	205	6	876	760	770	475	40	2872	2832	680	2181	1028	80	2100
900-650	250	6	876	760	770	555	50	3131	3072	680	2532	1028	90	2740
900-650	290	6	876	760	770	555	50	3131	3072	680	2532	1028	90	2875
900-650	340	6	876	760	770	555	50	3131	3072	680	2532	1028	90	3010

1581.85/01-EN

9.7 General arrangement drawings [mm]

9.7.1 Installation types BU/BUS

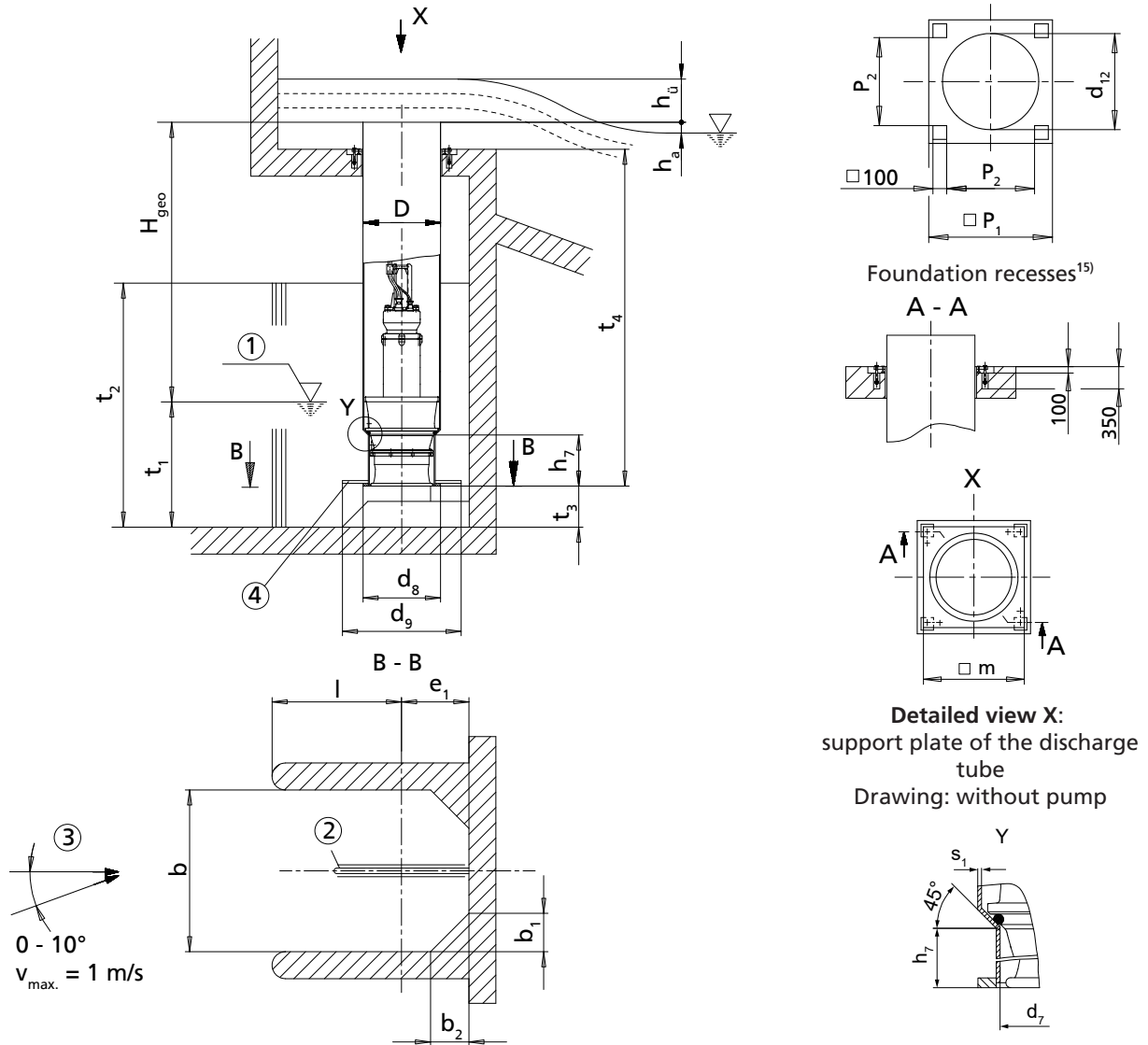

- ①: Minimum water level (values see diagram on the following pages)
- ②: Flow-straightening vane (⇒ Section 9.7.7, Page 146)
- ③: Approach flow
- ④: Suction umbrella; option for reducing the minimum water level t_1

Detailed view Y:
seating ring

Detailed view X:
support plate of the discharge
tube
Drawing: without pump

Table 92: Dimensions [mm]

Size	D	b	b ₁		b ₂		d ₇	d ₈	d ₉	d ₁₂
			Suction umbrella		Suction umbrella					
			X	✓	X	✓				
			d ₈	d ₉	d ₈	d ₉				
600-390	610	1000	200	-	200	-	545	610	900	650
600-420	610	1250	250	-	250	-	530	610	900	650
700-390	711	1000	200	-	200	-	545	610	900	750
700-420	711	1250	250	-	250	-	530	610	900	750
700-460	711	1250	250	-	250	-	630	710	1050	750
800-460	813	1250	250	-	250	-	630	710	1050	850
800-580	813	1500	300	-	300	-	720	810	1300	850

1581.85/01-EN

¹⁵ All dimensions for foundation recesses apply to discharge tube design without intermediate flange.

Size	D	b	b ₁		b ₂		d ₇	d ₈	d ₉	d ₁₂
			Suction umbrella		Suction umbrella					
			✗	✓	✗	✓				
			d ₈	d ₉	d ₈	d ₉				
900-630	914	1500	300	-	300	-	820	910	1300	970
900-650	914	1800	360	-	360	-	800	910	1500	970

Table 93: Dimensions [mm]

Size	e ₁ ¹⁶⁾		h ₇	h _a	l _{min.}	m	p ₁	p ₂	s ₁	t ₃ ¹⁶⁾	t _{4 min.} ¹⁷⁾
	Suction umbrella										
	✗	✓									
	d ₈	d ₉									
600-390	400	540	510	100	580	700	800	540	7	280	2500
600-420	400	540	480	100	850	700	800	540	7	270	2450
700-390	400	540	510	100	580	800	900	640	8	280	2800
700-420	400	540	480	100	850	800	900	640	8	270	2800
700-460	450	620	540	100	850	800	900	640	8	320	2750
800-460	450	620	540	100	850	910	1000	740	8	320	3150
800-580	500	750	625	100	1000	910	1000	740	8	380	2800 ¹⁸⁾ 3150 ¹⁹⁾
900-630	550	750	575	100	1000	1050	1120	860	8	420	3200
900-650	550	850	670	100	1300	1050	1120	860	8	420	3150

t₂ = 1.1 x water level, maximum 2 x t₁
 Height of corner lining (b₁ and b₂) like t₂

Permissible dimensional tolerances:

- Tolerances in building construction to DIN 18202, Part 4, Group B
- Welded design: B/F to DIN EN ISO 13920
- Tolerances for conical seat (detailed view Y): ISO 2768-mH

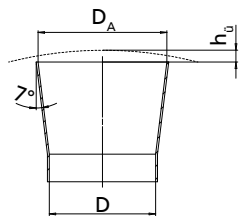

Overflow head
h₀

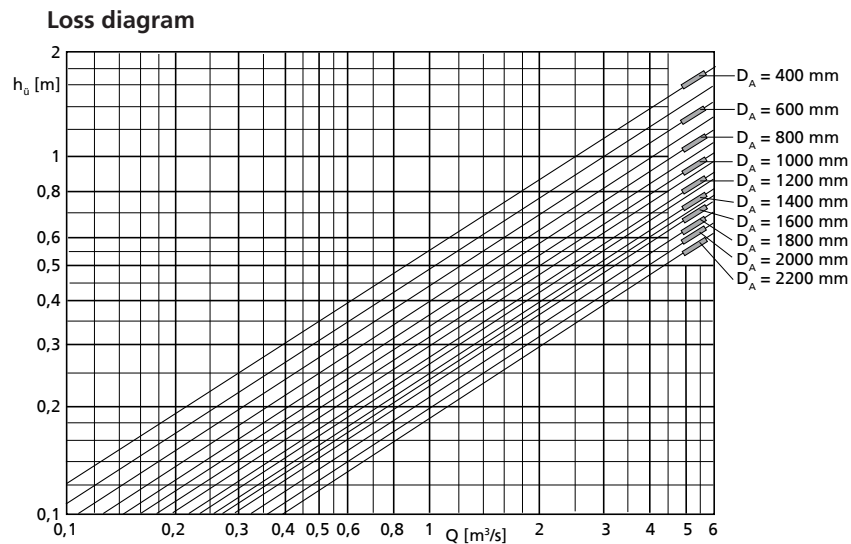

Loss diagram

Calculation formulas:

$$H = H_{geo} + \Delta H_v$$

¹⁶ Observe this dimension.

¹⁷ Dimension for maximum motor length

¹⁸ Up to motor sizes 205 6 and 160 8

¹⁹ From motor sizes 250 6 and 205 8

- ΔH_v
- Overflow head $h_{\text{ü}}$ (see diagram)
 - Loss in the riser (pipe friction)
 - Outlet loss $v^2/2g$ (v refers to D_A)

Overflow head $h_{\text{ü}}$ depends on Q and the discharge diameter D_A . The characteristic curve values only apply to unimpeded outlet in all directions; otherwise they are approximate values only.

Minimum water level diagrams

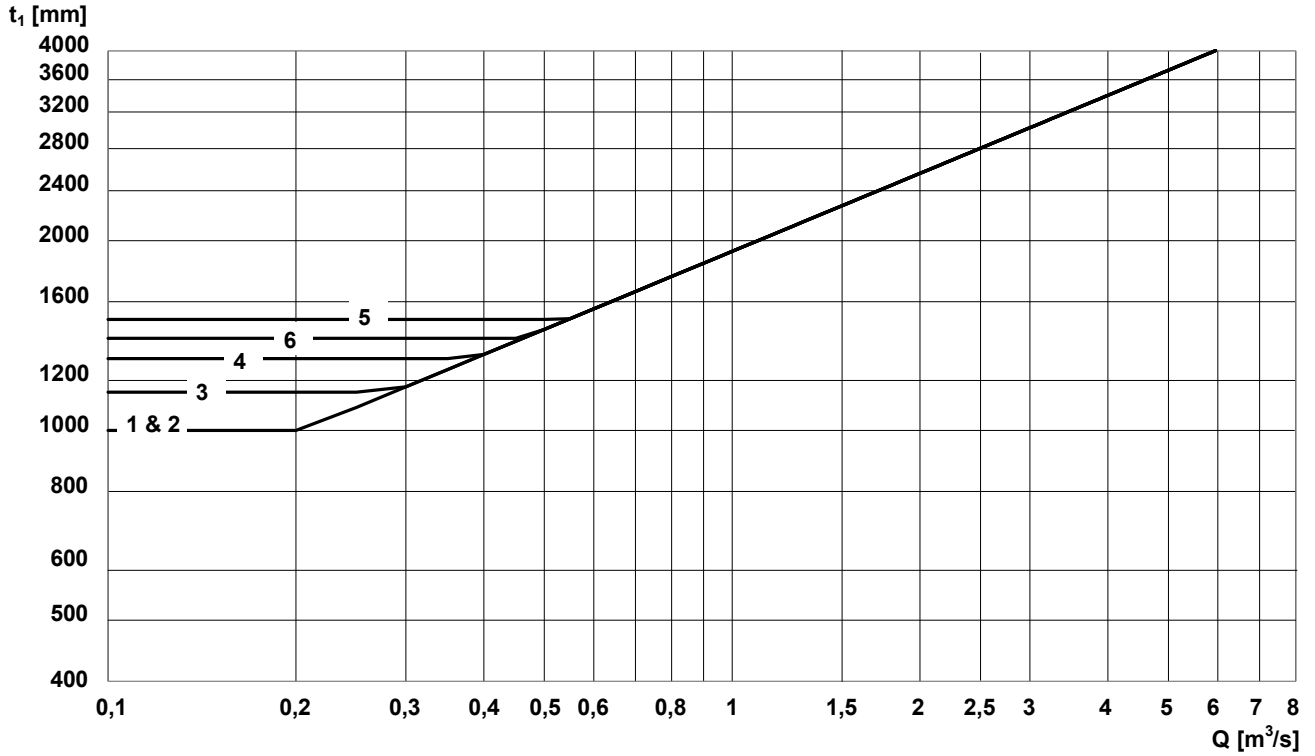

Fig. 99: Open intake chamber, design without suction umbrella $\varnothing d_8$

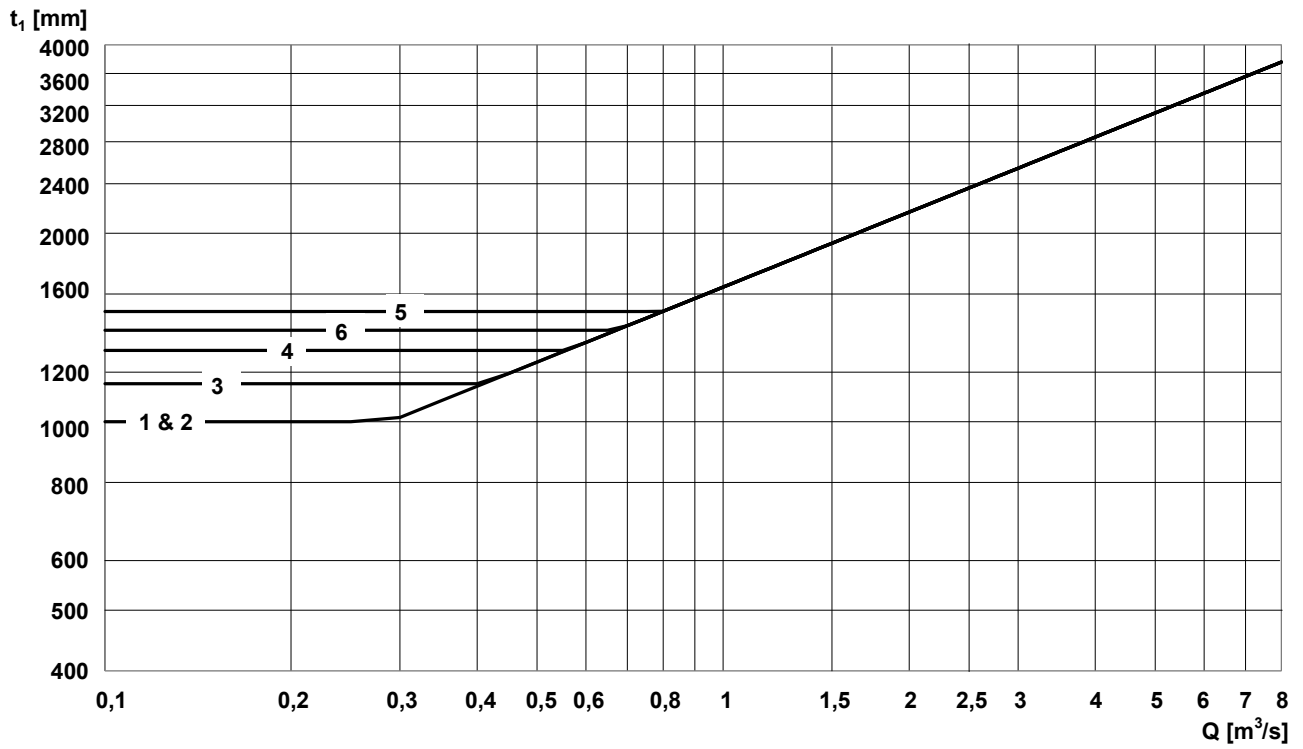

Fig. 100: Open intake chamber, design with suction umbrella $\varnothing d_s$

1	AmaCan D 600/700 - 390	4	AmaCan D 800 - 580
2	AmaCan D 600/700 - 420	5	AmaCan D 900 - 630
3	AmaCan D 700/800 - 460	6	AmaCan D 900/1000 - 650

9.7.2 Installation type BG

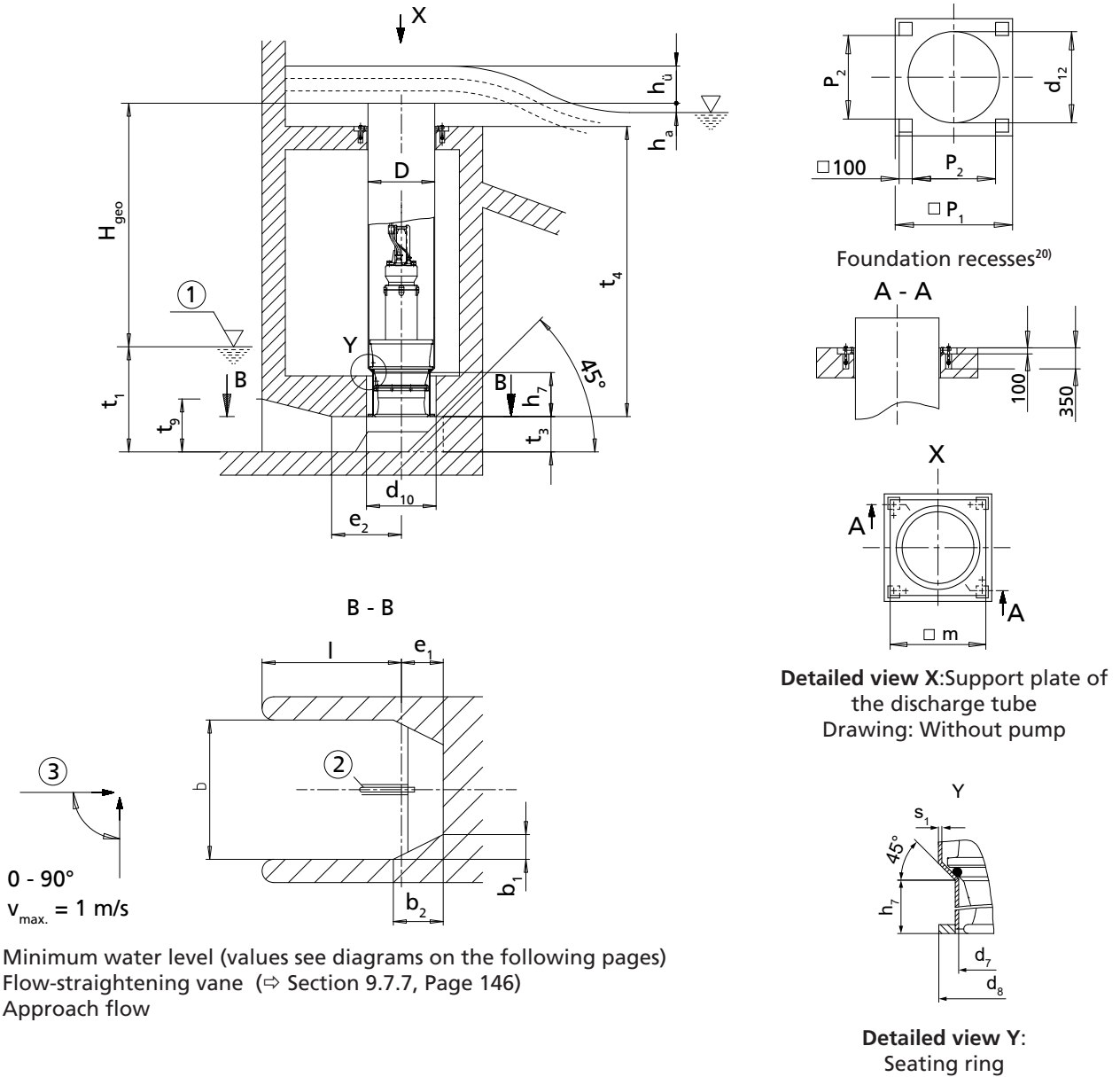

Table 94: Dimensions [mm]

Size	D	b	b ₁	b ₂	d ₇	d ₈	d ₁₀	d ₁₂	e ₁ ²¹⁾	e ₂
600-390	610	1000	200	400	545	610	660	650	330	500
600-420	610	1250	250	500	530	610	660	650	375	625
700-390	711	1000	200	400	545	610	660	750	330	500
700-420	711	1250	250	500	530	610	660	750	375	625
700-460	711	1250	250	500	630	710	760	750	380	625
800-460	813	1250	250	500	630	710	760	850	380	625
800-580	813	1500	300	600	720	810	860	850	450	750
900-630	914	1500	300	600	820	910	960	970	480	750
900-650	914	1800	360	720	800	910	960	970	520	900

1581.85/01-EN

²⁰ All dimensions for foundation recesses apply to discharge tube design without intermediate flange.

²¹ Observe this dimension.

Table 95: Dimensions [mm]

Size	h_a	h_7	$l_{min.}$	m	p_1	p_2	s_1	$t_3^{21)}$	$t_4 min.^{22)}$	t_9
600-390	100	510	1000	700	800	540	7	280	2500	375
600-420	100	480	1250	700	800	540	7	270	2450	470
700-390	100	510	1000	800	900	640	8	280	2800	375
700-420	100	480	1250	800	900	640	8	270	2800	470
700-460	100	540	1250	800	900	640	8	320	2750	470
800-460	100	540	1250	910	1000	740	8	320	3150	470
800-580	100	625	1500	910	1000	740	8	380	2800 ²³⁾ 3150 ²⁴⁾	570
900-630	100	575	1500	1050	1120	860	8	420	3200	570
900-650	100	670	1800	1050	1120	860	8	420	3150	660

Permissible dimensional tolerances:

- Tolerances in building construction to DIN 18202, Part 4, Group B
- Welded design: B/F to DIN EN ISO 13920
- Tolerances for conical seat (detailed view Y): ISO 2768-mH

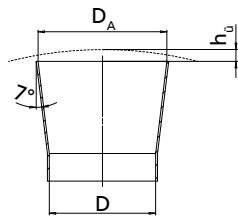

Overflow head
 h_0

Loss diagram

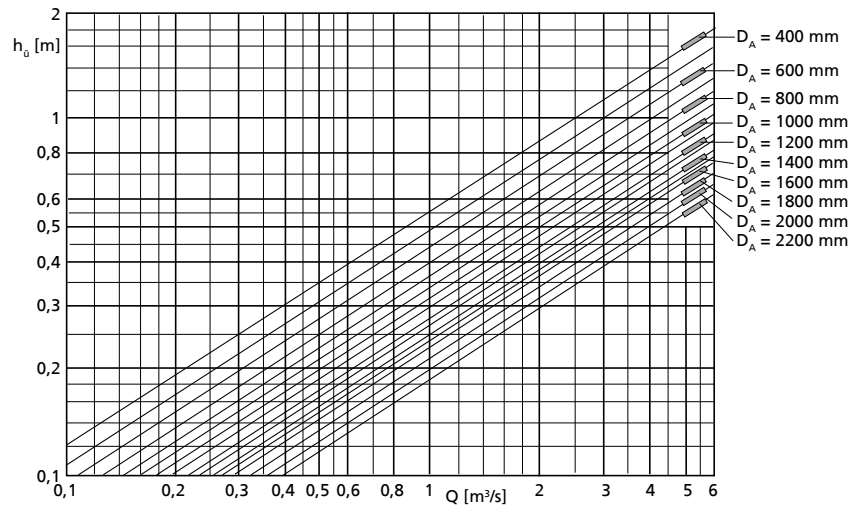

Loss diagram

Calculation formulas:

$$H = H_{geo} + \Delta H_v$$

- ΔH_v
- Overflow head h_0 (see diagram)
 - Loss in the riser (pipe friction)
 - Outlet loss $v^2/2g$ (v refers to D_A)

Overflow head h_0 depends on Q and the discharge diameter D_A . The characteristic curve values only apply to unimpeded outlet in all directions; otherwise they are approximate values only.

²² Dimension for maximum motor length

²³ Up to motor sizes 205 6 and 160 8

²⁴ From motor sizes 250 6 and 205 8

Minimum water level diagrams

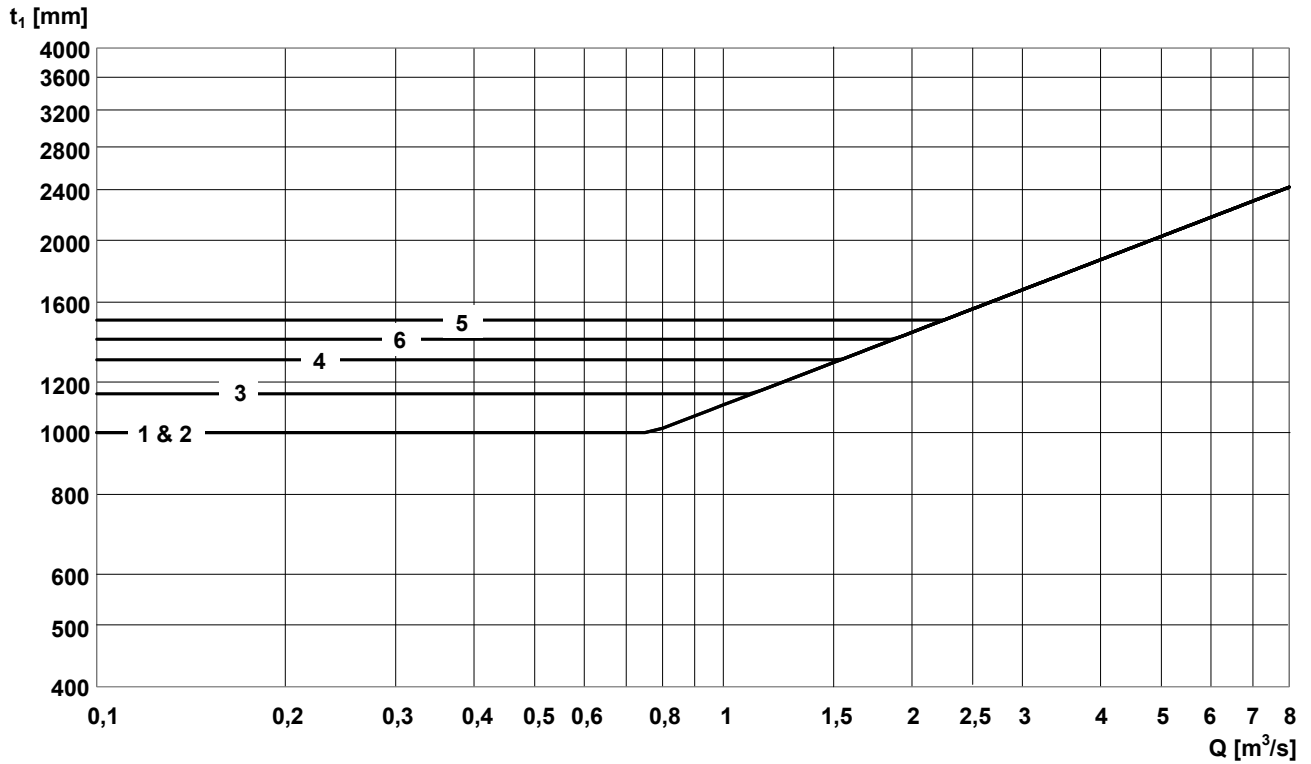
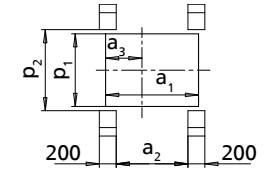
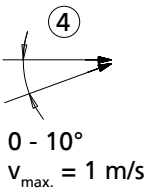
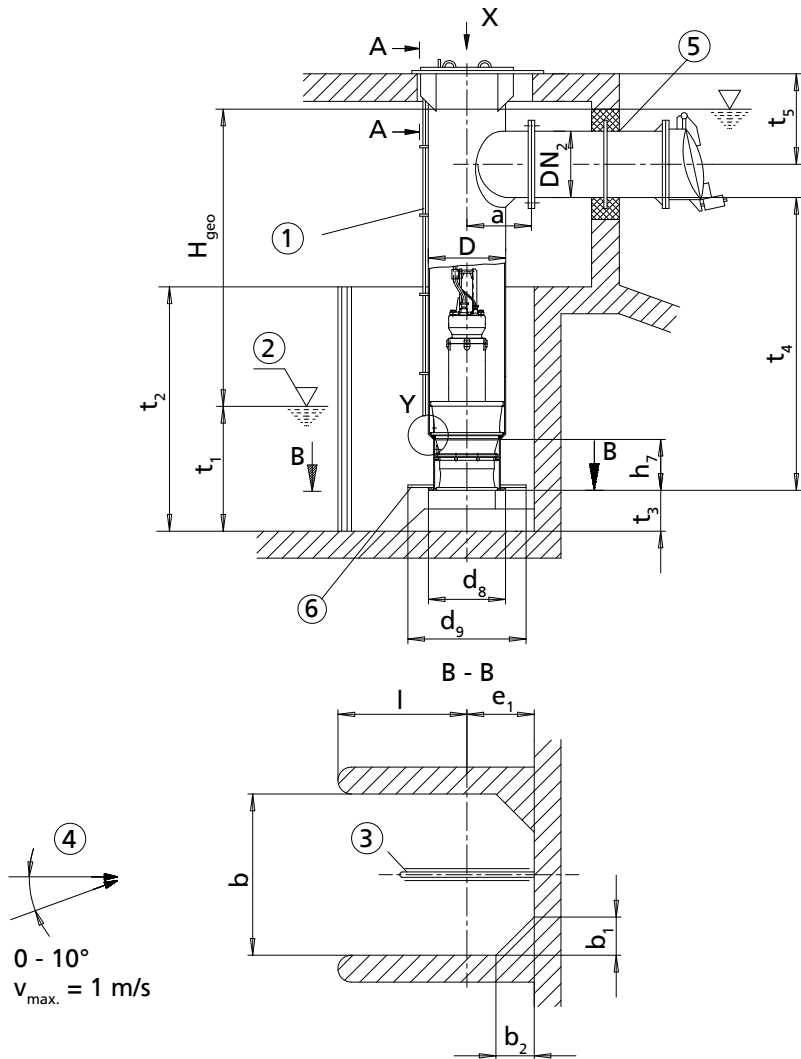

Fig. 101: Covered intake chamber

1	AmaCan D 600/700 - 390	4	AmaCan D 800 - 580
2	AmaCan D 600/700 - 420	5	AmaCan D 900 - 630
3	AmaCan D 700/800 - 460	6	AmaCan D 900/1000 - 650

9.7.3 Installation types CU/CUS



Foundation recesses²⁵⁾

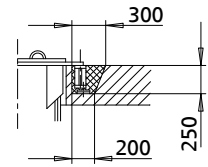

Section A - A

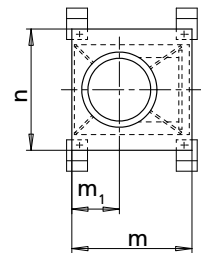

Detailed view X:
support plate of the discharge tube
Drawing: without pump

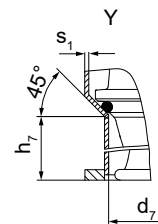

Detailed view Y:
seating ring

- ①: Vent line
- ②: Minimum water level (values see diagram on the following pages)
- ③: Flow-straightening vane (⇒ Section 9.7.7, Page 146)
- ④: Approach flow
- ⑤: Connect the discharge pipe to the discharge tube without transmitting any stresses or strains.
- ⑥: Suction umbrella; option for reducing the minimum water level t_1

Table 96: Dimensions [mm]

Size	DN ₂ min.	DN ₂ max.	D	a	a ₁ ²⁶⁾	a ₂ ²⁶⁾	a ₃ ²⁶⁾	b	b ₁		b ₂	
									Suction umbrella		Suction umbrella	
									✗	✓	✗	✓
									d ₈	d ₉	d ₈	d ₉
600-390	350	600	610	580	1000	750	380	1000	200	-	200	-
600-420	350	600	610	580	1000	750	380	1250	250	-	250	-
700-390	400	700	711	650	1120	870	430	1000	200	-	200	-
700-420	400	700	711	650	1120	870	430	1250	250	-	250	-
700-460	400	700	711	650	1120	870	430	1250	250	-	250	-
800-460	500	800	813	700	1220	970	480	1250	250	-	250	-
800-580	500	800	813	700	1220	970	480	1500	300	-	300	-

²⁵ All dimensions for foundation recesses apply to discharge tube design without intermediate flange.

²⁶ Designed for DN₂ max.

Size	DN ₂ min.	DN ₂ max.	D	a	a ₁ ²⁶⁾	a ₂ ²⁶⁾	a ₃ ²⁶⁾	b	b ₁		b ₂	
									Suction umbrella		Suction umbrella	
									✗	✓	✗	✓
									d ₈	d ₉	d ₈	d ₉
900-630	600	900	914	760	1320	1070	530	1500	300	-	300	-
900-650	600	900	914	760	1320	1070	530	1800	360	-	360	-

Table 97: Dimensions [mm]

Size	d ₇	d ₈	d ₉	e ₁ ²⁷⁾		h ₇	l _{min.}	m ²⁶⁾	m ₁ ²⁶⁾	n ²⁶⁾	p ₁ ²⁶⁾	p ₂ ²⁶⁾	s ₁	t ₃ ²⁷⁾	t _{4 min.} ²⁸⁾	t _{5 min.} ²⁸⁾
				Suction umbrella												
				✗	✓											
				d ₈	d ₉											
600-390	545	610	900	400	540	510	580	1050	405	1160	860	960	7	280	2650	720
600-420	530	610	900	400	540	480	850	1050	405	1160	860	960	7	270	2600	720
700-390	545	610	900	400	540	510	580	1170	455	1260	960	1060	8	280	2950	770
700-420	530	610	900	400	540	480	850	1170	455	1260	960	1060	8	270	2950	770
700-460	630	710	1050	450	620	540	850	1170	455	1260	960	1060	8	320	2900	770
800-460	630	710	1050	450	620	540	850	1270	505	1375	1075	1175	8	320	3300	835
800-580	720	810	1300	500	750	625	1000	1270	505	1375	1075	1175	8	380	2950 ²⁹⁾ 3300 ³⁰⁾	835
900-630	820	910	1300	550	750	575	1000	1380	560	1480	1180	1280	8	420	3350	925
900-650	800	910	1500	550	850	670	1300	1380	560	1480	1180	1280	8	420	3300	925

t₂ = 1.1 x water level, maximum 2 x t₁
 Height of corner lining (b₁ and b₂) like t₂

Permissible dimensional tolerances:

- Tolerances in building construction to DIN 18202, Part 4, Group B
- Welded design: B/F to DIN EN ISO 13920
- Tolerances for conical seat (detailed view Y): ISO 2768-mH
- Discharge flanges to DIN EN 1092-1 PN6 / DIN EN 1092-2 PN6

Loss diagram

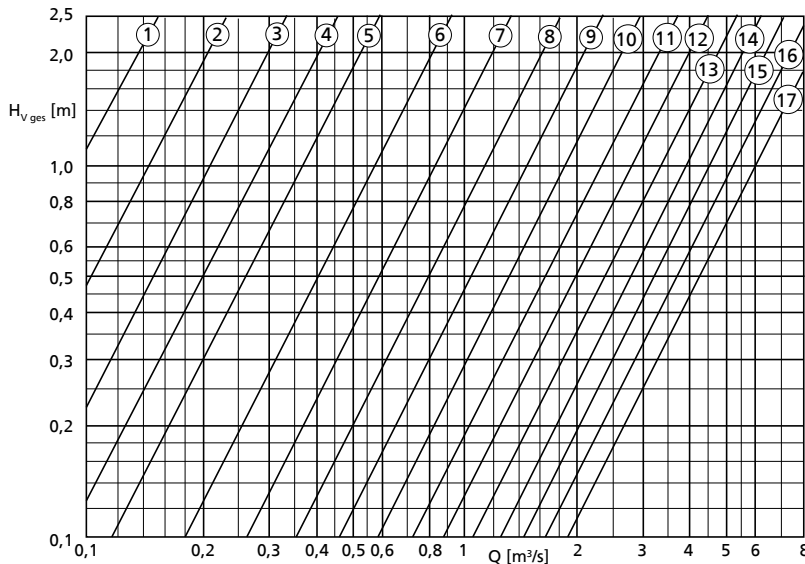

- ① - DN₂ = 200 mm
- ② - DN₂ = 250 mm
- ③ - DN₂ = 300 mm
- ④ - DN₂ = 350 mm
- ⑤ - DN₂ = 400 mm
- ⑥ - DN₂ = 500 mm
- ⑦ - DN₂ = 600 mm
- ⑧ - DN₂ = 700 mm
- ⑨ - DN₂ = 800 mm
- ⑩ - DN₂ = 900 mm
- ⑪ - DN₂ = 1000 mm
- ⑫ - DN₂ = 1100 mm
- ⑬ - DN₂ = 1200 mm
- ⑭ - DN₂ = 1300 mm
- ⑮ - DN₂ = 1400 mm
- ⑯ - DN₂ = 1500 mm
- ⑰ - DN₂ = 1600 mm

1581.85/01-EN

²⁷ Observe this dimension.
²⁸ Dimension for maximum motor length
²⁹ Up to motor sizes 205 6 and 160 8
³⁰ From motor sizes 250 6 and 205 8

Calculation formulas:

$$H = H_{geo} + \Delta H_v$$

ΔH_v

- Loss in the riser (pipe friction)
- $H_{v, ges.}$ (see diagram)

$H_{v, ges.}$ comprises:

- Elbow
- Discharge pipe length = 5 x DN_2
- Swing check valve
- Outlet losses $v^2/2g$

Minimum water level diagrams

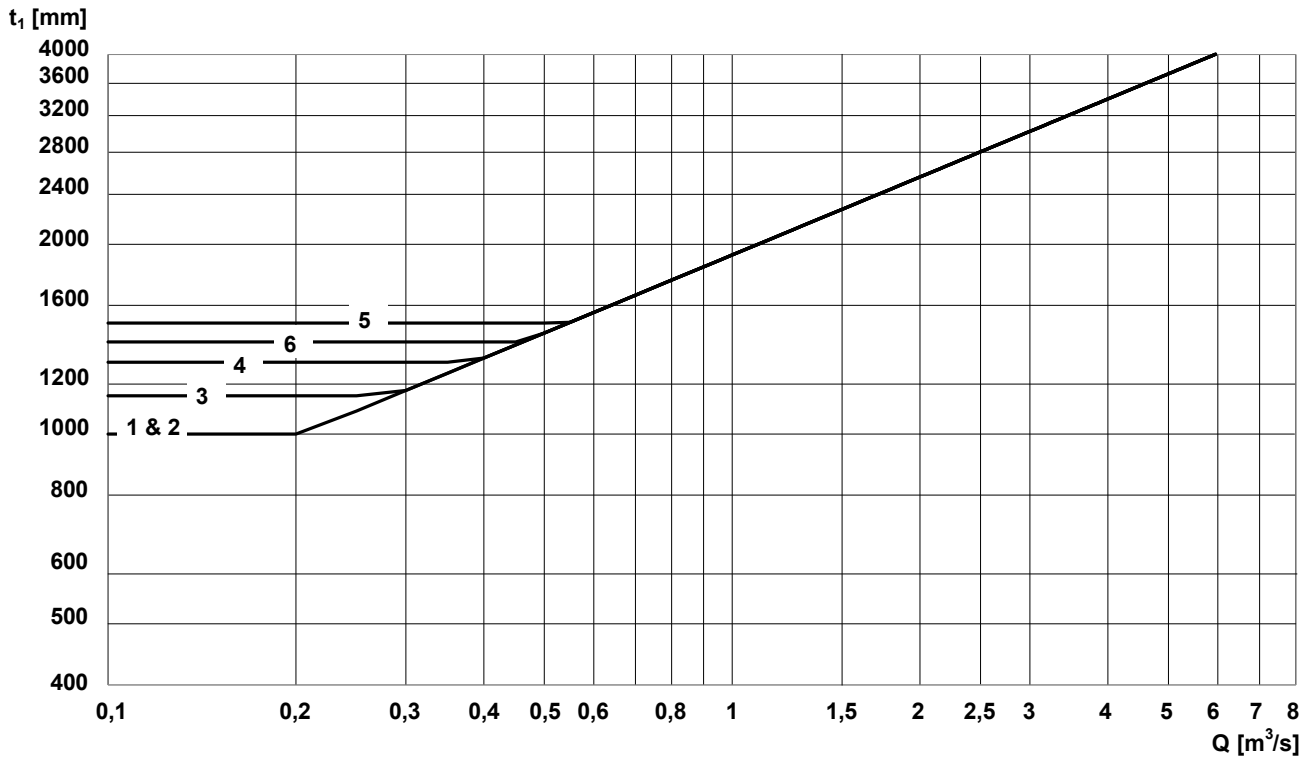

Fig. 102: Open intake chamber, design without suction umbrella $\varnothing d_8$

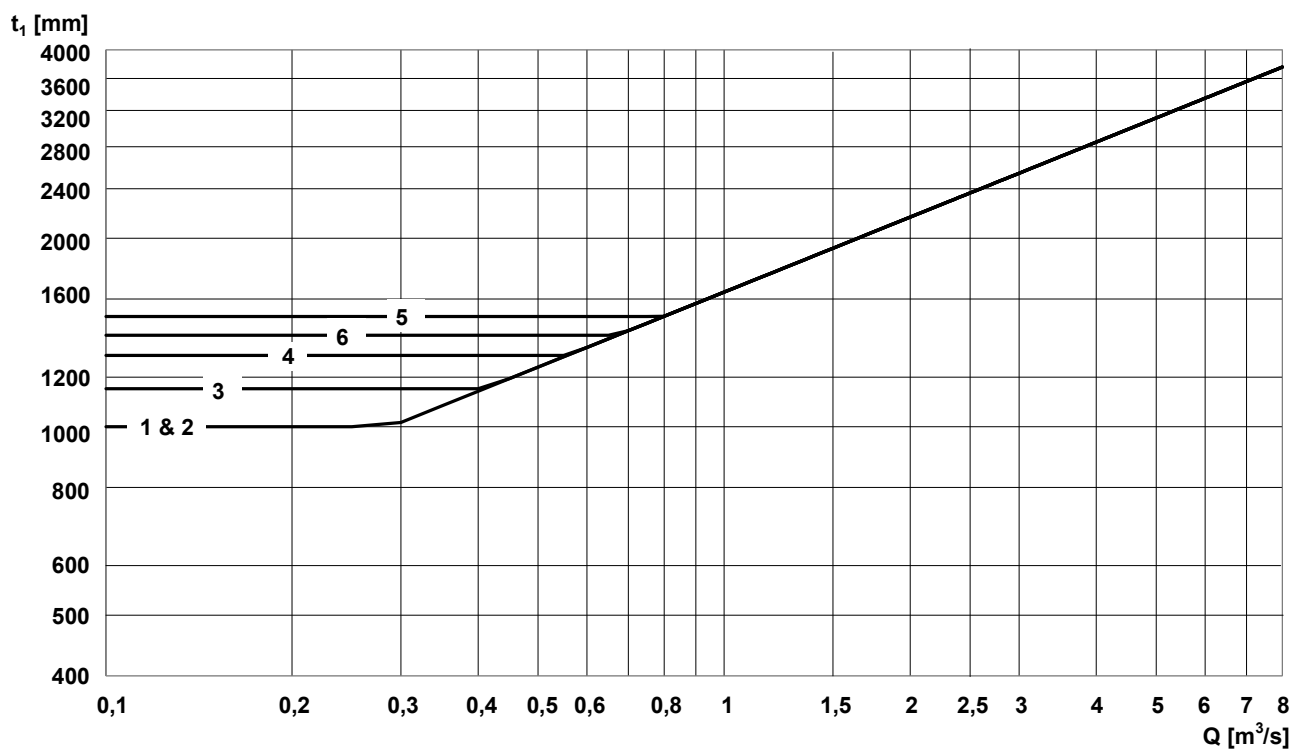
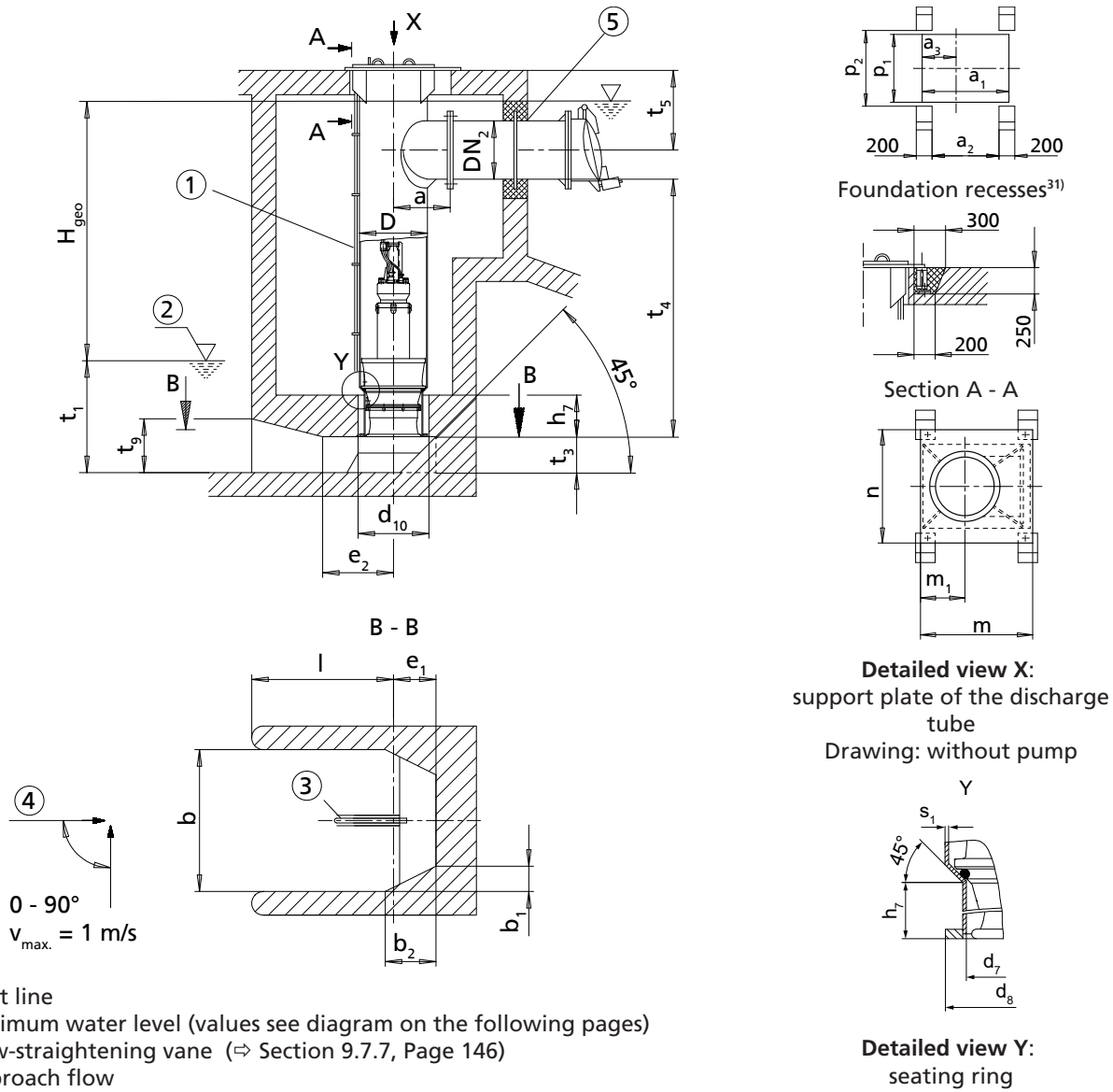

Fig. 103: Open intake chamber, design with suction umbrella $\varnothing d_s$

1	AmaCan D 600/700 - 390	4	AmaCan D 800 - 580
2	AmaCan D 600/700 - 420	5	AmaCan D 900 - 630
3	AmaCan D 700/800 - 460	6	AmaCan D 900/1000 - 650

9.7.4 Installation type CG



- ①: Vent line
- ②: Minimum water level (values see diagram on the following pages)
- ③: Flow-straightening vane (⇒ Section 9.7.7, Page 146)
- ④: Approach flow
- ⑤: Connect the discharge pipe to the discharge tube without transmitting any stresses or strains.

Table 98: Dimensions [mm]

Size	DN _{2 min.}	DN _{2 max.}	D	a	a ₁ ³²⁾	a ₂ ³²⁾	a ₃ ³²⁾	b	b ₁	b ₂	d ₇	d ₈	d ₁₀
600-390	350	600	610	580	1000	750	380	1000	200	400	545	610	660
600-420	350	600	610	580	1000	750	380	1250	250	500	530	610	660
700-390	400	700	711	650	1120	870	430	1000	200	400	545	610	660
700-420	400	700	711	650	1120	870	430	1250	250	500	530	610	660
700-460	400	700	711	650	1120	870	430	1250	250	500	630	710	760
800-460	500	800	813	700	1220	970	480	1250	250	500	630	710	760
800-580	500	800	813	700	1220	970	480	1500	300	600	720	810	860
900-630	600	900	914	760	1320	1070	530	1500	300	600	820	910	960
900-650	600	900	914	760	1320	1070	530	1800	360	720	800	910	960

³¹ All dimensions for foundation recesses apply to discharge tube design without intermediate flange.

³² Designed for DN_{2 max.}

Table 99: Dimensions [mm]

Size	e ₁ ³³⁾	e ₂	h ₇	l _{min.}	m ³²⁾	m ₁ ³²⁾	n ³²⁾	p ₁ ³²⁾	p ₂ ³²⁾	s ₁	t ₃ ³³⁾	t _{4 min.} ³⁴⁾	t _{5 min.} ³²⁾	t ₉
600-390	330	500	510	1000	1050	405	1160	860	960	7	280	2650	720	375
600-420	375	625	480	1250	1050	405	1160	860	960	7	270	2600	720	470
700-390	330	500	510	1000	1170	455	1260	960	1060	8	280	2950	770	375
700-420	375	625	480	1250	1170	455	1260	960	1060	8	270	2950	770	470
700-460	380	625	540	1250	1170	455	1260	960	1060	8	320	2900	770	470
800-460	380	625	540	1250	1270	505	1375	1075	1175	8	320	3300	835	470
800-580	450	750	625	1500	1270	505	1375	1075	1175	8	380	2950 ³⁵⁾ 3300 ³⁶⁾	835	570
900-630	480	750	575	1500	1380	560	1480	1180	1280	8	420	3350	925	570
900-650	520	900	670	1800	1380	560	1480	1180	1280	8	420	3300	925	660

Permissible dimensional tolerances:

- Tolerances in building construction to DIN 18202, Part 4, Group B
- Welded design: B/F to DIN EN ISO 13920
- Tolerances for conical seat (detailed view Y): ISO 2768-mH
- Discharge flanges to DIN EN 1092-1 PN6 / DIN EN 1092-2 PN6

Loss diagram

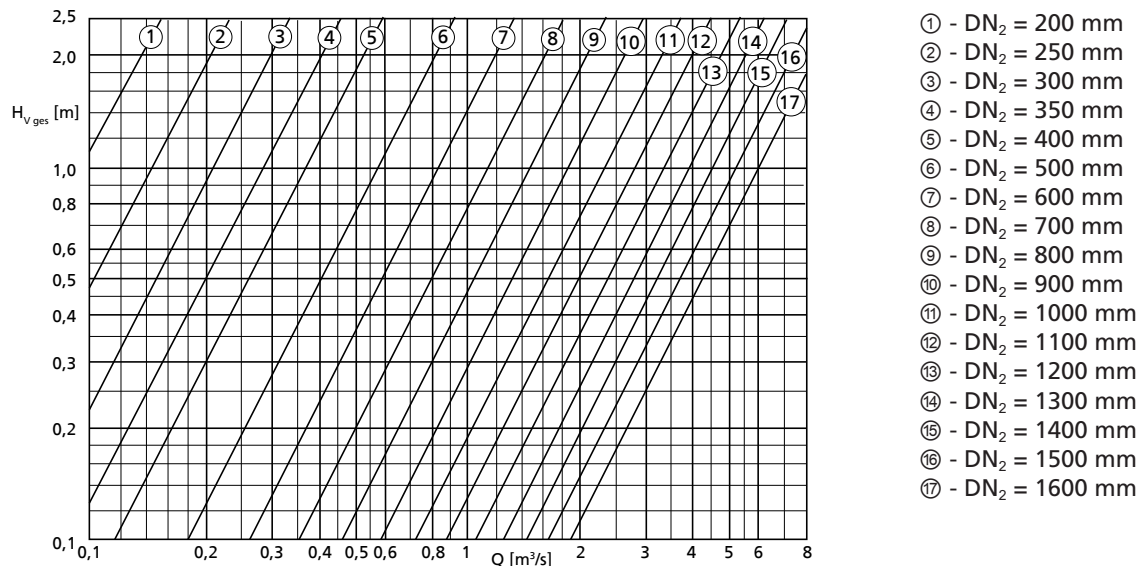

Calculation formulas:

$$H = H_{geo} + \Delta H_v$$

ΔH_v

- Loss in the riser (pipe friction)
- $H_{v ges.}$ (see diagram)

$H_{v ges.}$ comprises:

- Elbow
- Discharge pipe length = 5 x DN₂
- Swing check valve
- Outlet losses $v^2/2g$

1581.85/01-EN

³³ Observe this dimension.

³⁴ Dimension for maximum motor length

³⁵ Up to motor sizes 205 6 and 160 8

³⁶ From motor sizes 250 6 and 205 8

Minimum water level diagrams

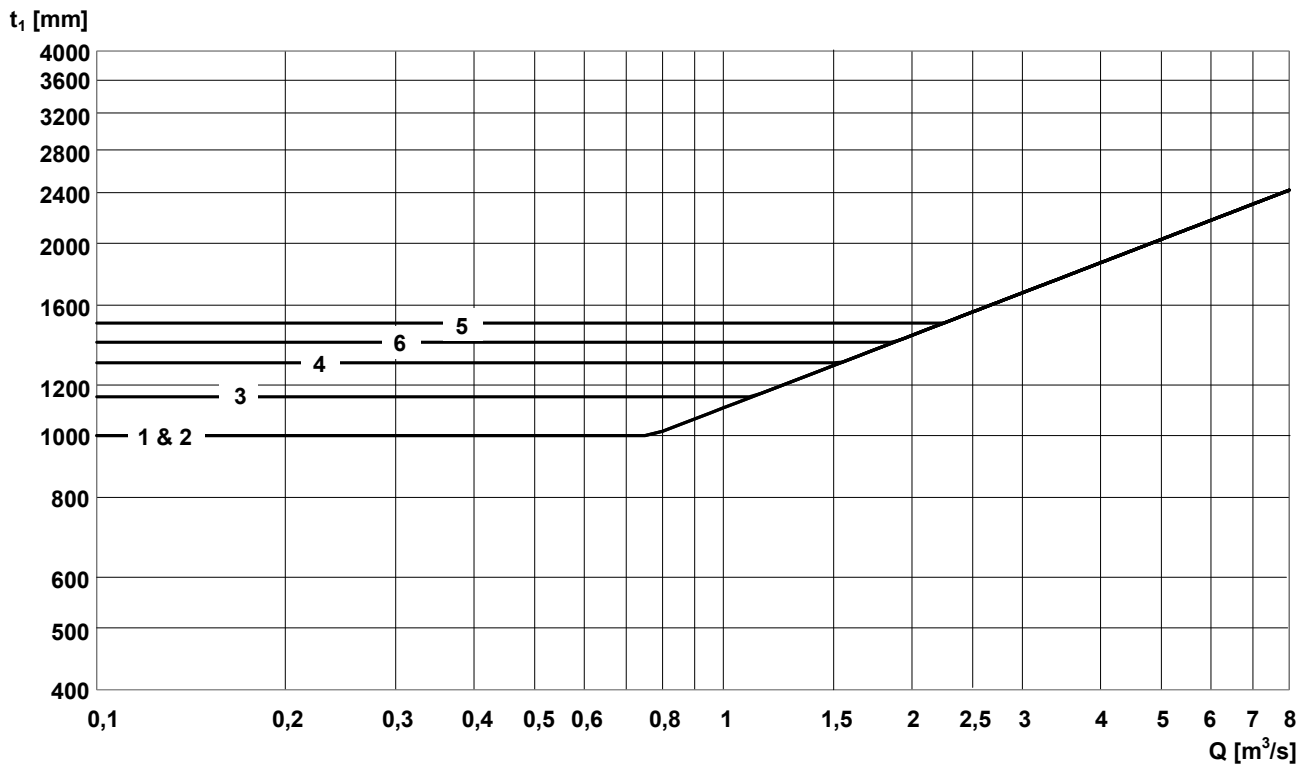
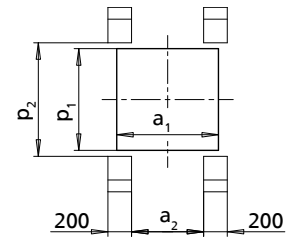
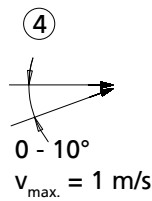
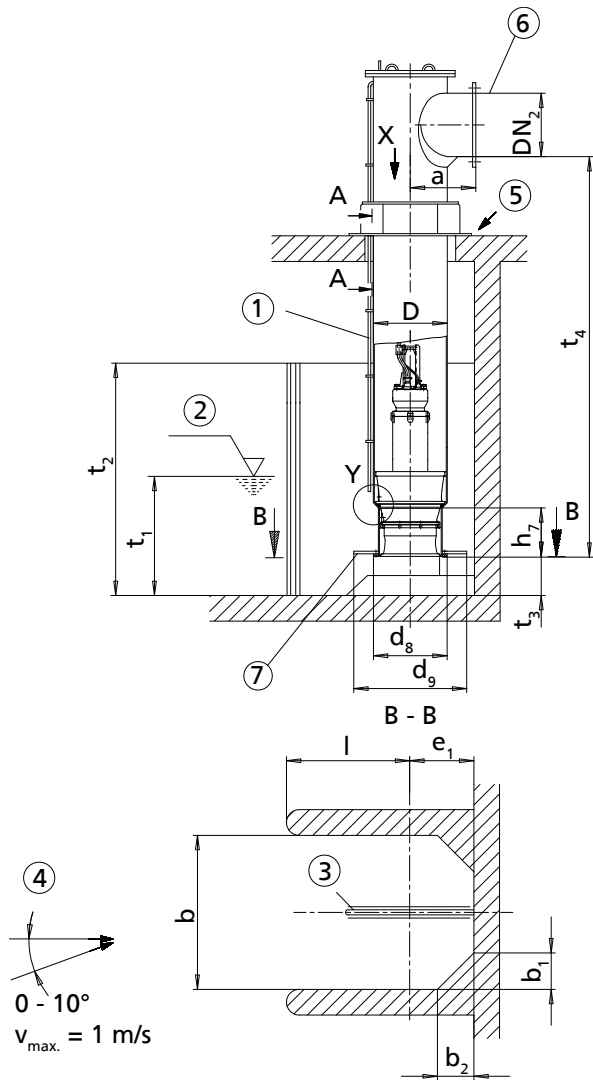

Fig. 104: Covered intake chamber

1	AmaCan D 600/700 - 390	4	AmaCan D 800 - 580
2	AmaCan D 600/700 - 420	5	AmaCan D 900 - 630
3	AmaCan D 700/800 - 460	6	AmaCan D 900/1000 - 650

9.7.5 Installation types DU/DUS



Foundation recesses³⁷⁾

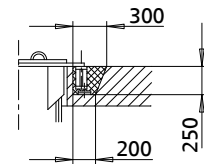

Section A - A

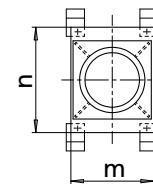

Detailed view X:
support plate of the discharge tube
Drawing: without pump

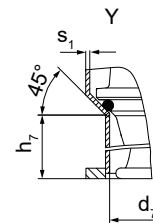

Detailed view Y:
seating ring

- ①: Vent line
- ②: Minimum water level (values see diagram on the following pages)
- ③: Flow-straightening vane (⇔ Section 9.7.7, Page 146)
- ④: Approach flow
- ⑤: Not pressure-proof
- ⑥: Connect the discharge pipe to the discharge tube without transmitting any stresses or strains.
- ⑦: Suction umbrella; option for reducing the minimum water level t_1

Table 100: Dimensions [mm]

Size	DN ₂ min.	DN ₂ max.	D	a	a ₁	a ₂	b	b ₁		b ₂	
								Suction umbrella		Suction umbrella	
								X	✓	X	✓
								d ₈	d ₉	d ₈	d ₉
600-390	350	600	610	580	760	510	1000	200	-	200	-
600-420	350	600	610	580	760	510	1250	250	-	250	-
700-390	400	700	711	650	860	610	1000	200	-	200	-
700-420	400	700	711	650	860	610	1250	250	-	250	-
700-460	400	700	711	650	860	610	1250	250	-	250	-
800-460	500	800	813	700	960	710	1250	250	-	250	-
800-580	500	800	813	700	960	710	1500	300	-	300	-

1581.85/01-EN

³⁷⁾ All dimensions for foundation recesses apply to discharge tube design without intermediate flange.

Size	DN ₂ min.	DN ₂ max.	D	a	a ₁	a ₂	b	b ₁		b ₂	
								Suction umbrella		Suction umbrella	
								✗	✓	✗	✓
								d ₈	d ₉	d ₈	d ₉
900-630	600	900	914	760	1060	810	1500	300	-	300	-
900-650	600	900	914	760	1060	810	1800	360	-	360	-

Table 101: Dimensions [mm]

Size	d ₇	d ₈	d ₉	e ₁ ³⁸⁾		h ₇	l _{min.}	m	n	p ₁	p ₂	s ₁	t ₃ ³⁸⁾	t _{4 min.} ³⁹⁾
				Suction umbrella										
				✗	✓									
				d ₈	d ₉									
600-390	545	610	900	400	540	510	580	830	1060	760	860	7	280	2650
600-420	530	610	900	400	540	480	850	830	1060	760	860	7	270	2600
700-390	545	610	900	400	540	510	580	930	1160	860	960	8	280	2950
700-420	530	610	900	400	540	480	850	930	1160	860	960	8	270	2950
700-460	630	710	1050	450	620	540	850	930	1160	860	960	8	320	2900
800-460	630	710	1050	450	620	540	850	1030	1260	960	1060	8	320	3300
800-580	720	810	1300	500	750	625	1000	1030	1260	960	1060	8	380	2950 ⁴⁰⁾ 3300 ⁴¹⁾
900-630	820	910	1300	550	750	575	1000	1130	1360	1060	1160	8	420	3350
900-650	800	910	1500	550	850	670	1300	1130	1360	1060	1160	8	420	3300

t₂ = 1.1 x water level, maximum 2 x t₁
 Height of corner lining (b₁ and b₂) like t₂

Permissible dimensional tolerances:

- Tolerances in building construction to DIN 18202, Part 4, Group B
- Welded design: B/F to DIN EN ISO 13920
- Tolerances for conical seat (detailed view Y): ISO 2768-mH
- Discharge flanges to DIN EN 1092-1 PN6 / DIN EN 1092-2 PN6

³⁸ Observe this dimension.

³⁹ Dimension for maximum motor length

⁴⁰ Up to motor sizes 205 6 and 160 8

⁴¹ From motor sizes 250 6 and 205 8

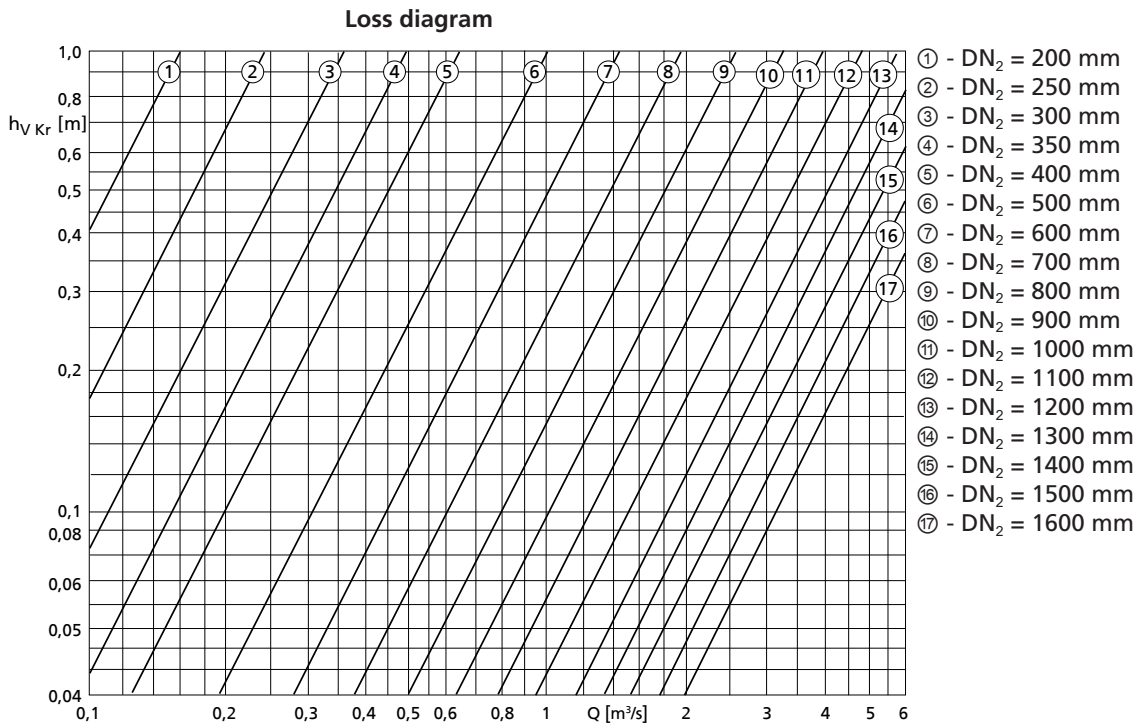

Calculation formulas:

$$H = H_{\text{geo}} + \Delta H_v$$

- ΔH_v
- Loss in the elbow $h_{v\text{Kr}}$ (see diagram)
 - Loss in the riser (pipe friction)
 - $H_{v\text{system}}$ (valves, etc.)

$HH_{v\text{System}}$ must be determined for the specific system.

Minimum water level diagrams

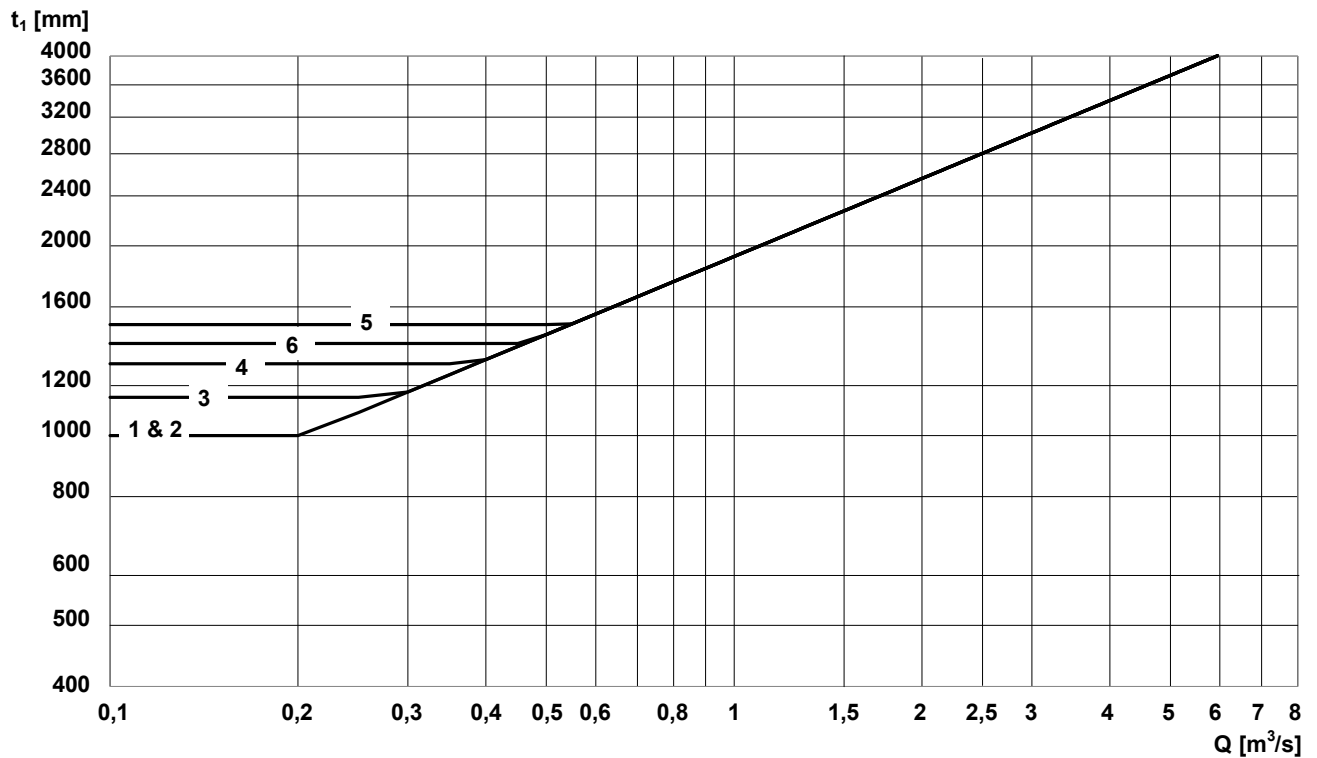

Fig. 105: Open intake chamber, design without suction umbrella $\varnothing d_8$

1581.85/01-EN

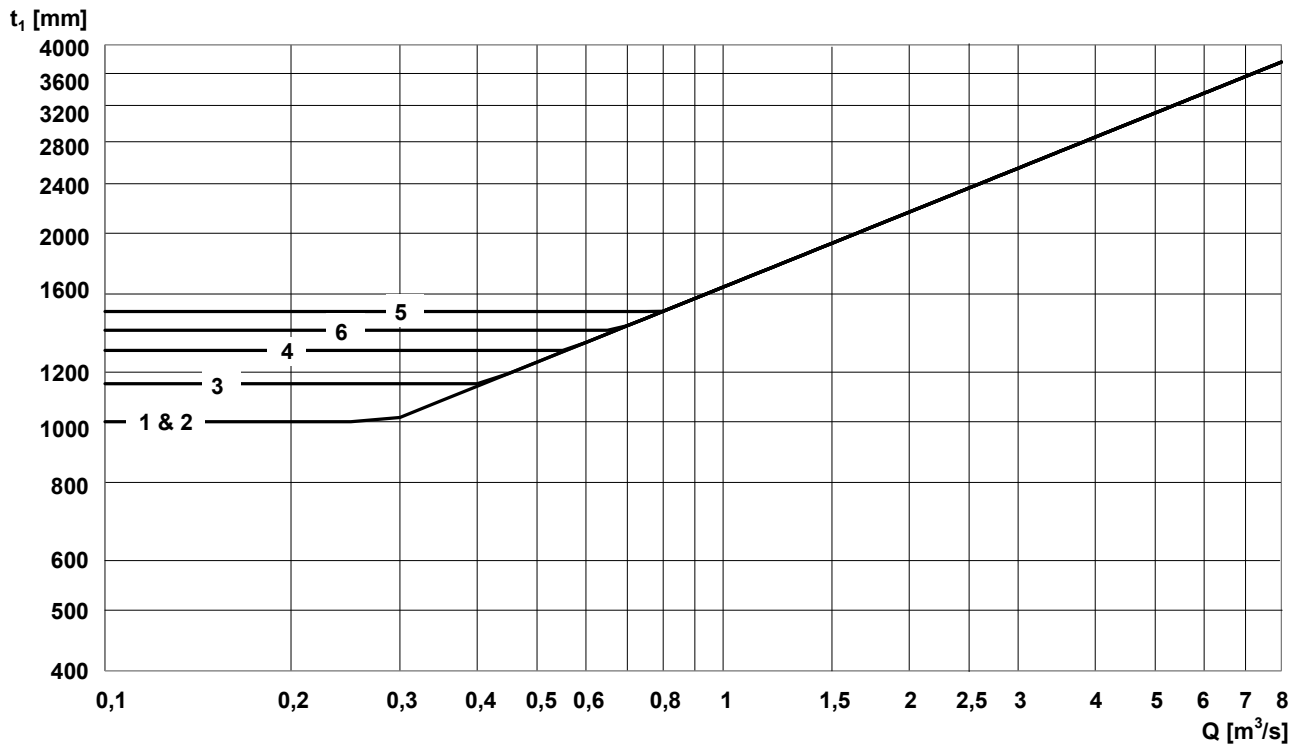
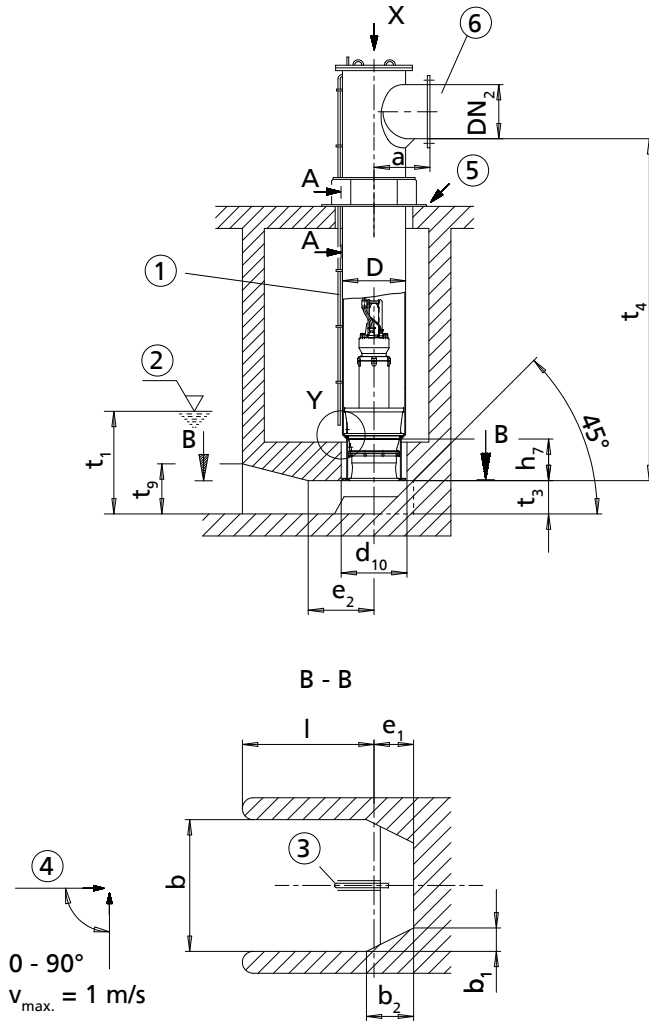

Fig. 106: Open intake chamber, design with suction umbrella $\varnothing d_s$

1	AmaCan D 600/700 - 390	4	AmaCan D 800 - 580
2	AmaCan D 600/700 - 420	5	AmaCan D 900 - 630
3	AmaCan D 700/800 - 460	6	AmaCan D 900/1000 - 650

9.7.6 Installation type DG



- ①: Vent line
- ②: Minimum water level (values see diagram on the following pages)
- ③: Flow-straightening vane (⇒ Section 9.7.7, Page 146)
- ④: Approach flow
- ⑤: Not pressure-proof
- ⑥: Connect the discharge pipe to the discharge tube without transmitting any stresses or strains.

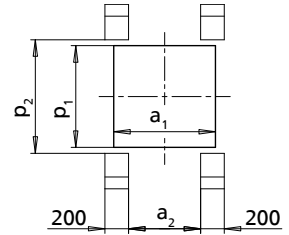

Foundation recesses⁴²⁾

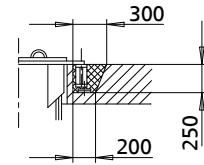

Section A - A

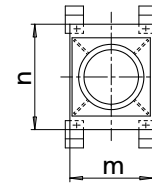

Detailed view X:
Support plate of the discharge tube
Drawing: Without pump

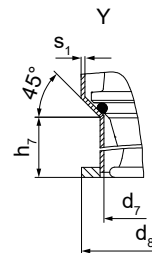

Detailed view Y:
Seating ring

Table 102: Dimensions [mm]

Size	DN _{2 min.}	DN _{2 max.}	D	a	a ₁	a ₂	b	b ₁	b ₂	d ₇	d ₈	d ₁₀
600-390	350	600	610	580	760	510	1000	200	400	545	610	660
600-420	350	600	610	580	760	510	1250	250	500	530	610	660
700-390	400	700	711	650	860	610	1000	200	400	545	610	660
700-420	400	700	711	650	860	610	1250	250	500	530	610	660
700-460	400	700	711	650	860	610	1250	250	500	630	710	760
800-460	500	800	813	700	960	710	1250	250	500	630	710	760
800-580	500	800	813	700	960	710	1500	300	600	720	810	860
900-630	600	900	914	760	1060	810	1500	300	600	820	910	960
900-650	600	900	914	760	1060	810	1800	360	720	800	910	960

1581.85/01-EN

⁴²⁾ All dimensions for foundation recesses apply to discharge tube design without intermediate flange.

Table 103: Dimensions [mm]

Size	e ₁ ⁴³⁾	e ₂	h ₇	l _{min.}	m	n	p ₁	p ₂	s ₁	t ₃ ⁴³⁾	t _{4 min.} ⁴⁴⁾	t ₉
600-390	330	500	510	1000	830	1060	760	860	7	280	2650	375
600-420	375	625	480	1250	830	1060	760	860	7	270	2600	470
700-390	330	500	510	1000	930	1160	860	960	8	280	2950	375
700-420	375	625	480	1250	930	1160	860	960	8	270	2950	470
700-460	380	625	540	1250	930	1160	860	960	8	320	2900	470
800-460	380	625	540	1250	1030	1260	960	1060	8	320	3300	470
800-580	450	750	625	1500	1030	1260	960	1060	8	380	2950 ⁴⁵⁾ 3300 ⁴⁶⁾	570
900-630	480	750	575	1500	1130	1360	1060	1160	8	420	3350	570
900-650	520	900	670	1800	1130	1360	1060	1160	8	420	3300	660

Permissible dimensional tolerances:

- Tolerances in building construction to DIN 18202, Part 4, Group B
- Welded design: B/F to DIN EN ISO 13920
- Tolerances for conical seat (detailed view Y): ISO 2768-mH
- Discharge flanges to ISO 7005/2, DIN 2501 PN6

Loss diagram

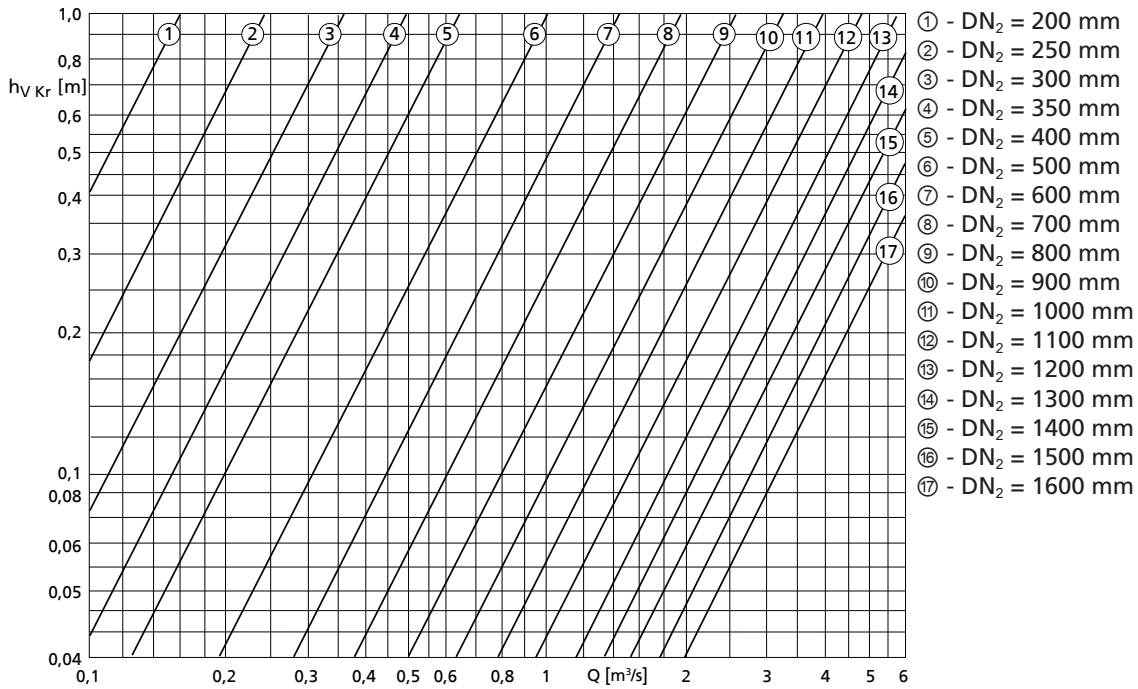

Calculation formulas:

$$H = H_{geo} + \Delta H_v$$

- ΔH_v
- Loss in the elbow $h_{v Kr}$ (see diagram)
 - Loss in the riser (pipe friction)
 - $H_{v system}$ (valves, etc.)

$HH_{v System}$ must be determined for the specific system.

⁴³ Observe this dimension.

⁴⁴ Dimension for maximum motor length

⁴⁵ Up to motor sizes 205 6 and 160 8

⁴⁶ From motor sizes 250 6 and 205 8

Minimum water level diagrams

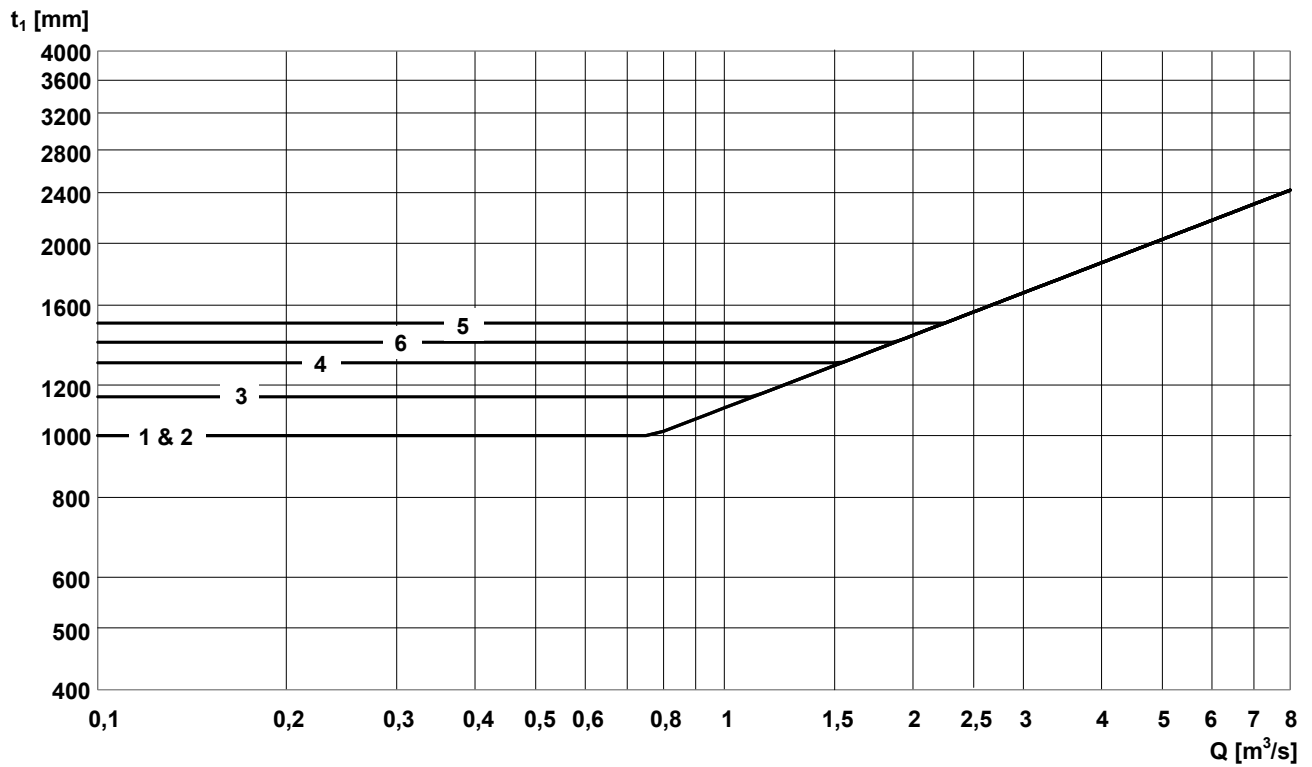

Fig. 107: Covered intake chamber

1	AmaCan D 600/700 - 390	4	AmaCan D 800 - 580
2	AmaCan D 600/700 - 420	5	AmaCan D 900 - 630
3	AmaCan D 700/800 - 460	6	AmaCan D 900/1000 - 650

9.7.7 Dimensions of the flow-straightening vane

Design of the intake chamber wall surfaces (to prevent vortex formation)

The flow-straightening vane is indispensable for the inlet conditions of the pump set. It prevents the development of a submerged vortex (floor vortex) which could cause a drop in performance, for example. In addition, the floor and wall surfaces of the intake chamber should be designed as a rough concrete surface. Rough surfaces minimise the separation of boundary layers that may cause wall and floor vortices.

Flow-straightening vane and intake chamber

- The anti-swirl baffles in the bellmouth must be aligned with the flow-straightening vane.
- The bail of the pump is oriented in the same direction as the anti-swirl baffles in the bellmouth.

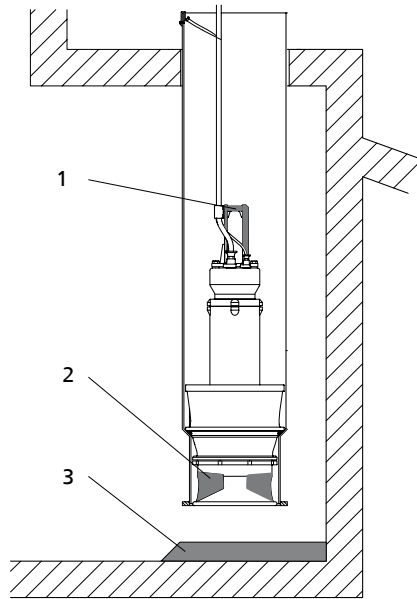
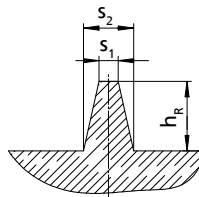

Fig. 108: Installation position of the pump set

1	Bail
2	Anti-swirl baffles
3	Flow-straightening vane

Variant 1
Flow-straightening vane cast from concrete



Variant 2
Steel section

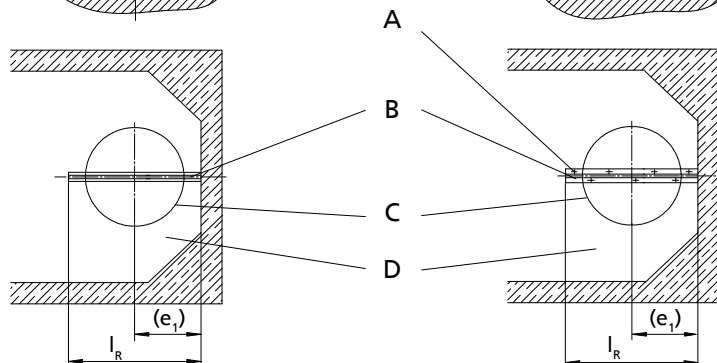
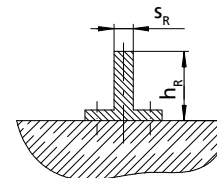

A	Bolted to the floor of the intake chamber
B	Flow-straightening vane centred beneath the discharge tube
C	Discharge tube
D	Intake chamber

Installation types BU/BUS, CU/CUS, DU/DUS
Table 104: Dimensions [mm]

Size	h_R	s_1	s_2	s_R	(e_1)		$l_R^{47)}$	
					Suction umbrella		Suction umbrella	
					\times	\checkmark	\times	\checkmark
					d_8	d_9	d_8	d_9
600-390	150	20	60	10	400	540	835	1050
600-420	190	20	70	10	400	540	875	1050
700-390	150	20	60	10	400	540	835	1050
700-420	190	20	70	10	400	540	875	1050
700-460	190	20	70	10	450	620	875	1150
800-460	190	20	70	10	450	620	875	1150
800-580	230	25	90	10	500	750	1100	1350
900-630	230	25	90	10	550	750	1200	1500
900-650	265	25	100	12	550	850	1300	1650

Installation types BG, CG, DG

Fig. 109: Flow-straightening vane for covered intake chamber

Table 105: Dimensions [mm]

Size	h_R	s_1	s_2	s_R	l_R
600-390	150	20	60	10	550
600-420	190	20	70	10	545
700-390	150	20	60	10	550
700-420	190	20	70	10	545
700-460	190	20	70	10	660
800-460	190	20	70	10	660
800-580	230	25	90	10	750
900-630	230	25	90	10	850
900-650	265	25	100	12	790

⁴⁷ Adjust length l_R of the flow straightening vane to the 45° angle of the intake chamber.

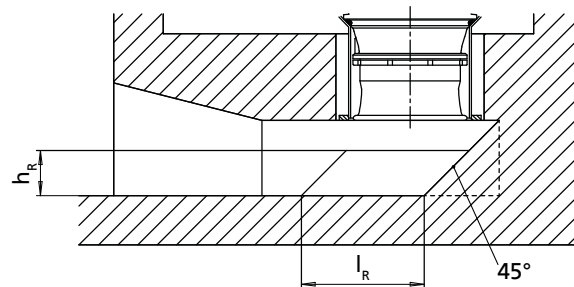
10 EU Declaration of Conformity

Manufacturer: **KSB SE & Co. KGaA**
Johann-Klein-Straße 9
67227 Frankenthal (Germany)

This EU Declaration of Conformity is issued under the sole responsibility of the manufacturer.

The manufacturer herewith declares that **the product:**

AmaCan D

KSB order number:

- is in conformity with the provisions of the following directives / regulations as amended from time to time:
 - Pump (set): 2006/42/EC Machinery Directive
 - Electrical components⁴⁸⁾: 2011/65/EU Restriction of the use of certain hazardous substances in electrical and electronic equipment (RoHS)
 - Electrical components⁴⁸⁾: 2014/30/EU Electromagnetic compatibility (EMC)
 - Pump: 2014/34/EU Equipment and protective systems intended for use in potentially explosive atmospheres (ATEX)

The manufacturer also declares that

- the following harmonised international standards have been applied:
 - ISO 12100
 - EN 809
 - EN 1127-1
 - EN IEC 61000-6-3
 - EN 61010-1
 - EN 60034-1:2010, EN 60034-5/A1:2007
 - EN IEC 60079-0:2018, EN 60079-1:2014
 - EN 80079-36:2016, EN 80079-37:2016

In compliance with Directive 2014/34/EU, the product is marked as follows: **Ⓔ II 2G Ex db h IIB T3 Gb or T4 Gb**

The following type test certificates are available for integrated motors with **Ⓔ II 2G Ex db IIB T3 Gb or T4 Gb** type of protection:

EU type test certificate	R22	IBExU08ATEX1064X
EU type test certificate	R28	IBExU07ATEX1108X
EU type test certificate	R31	IBExU08ATEX1106X

The manufacturer's quality assurance system is monitored by 0035 TÜV Rheinland Industrie Service GmbH.

Person authorised to compile the technical file:

Name
Function
Address (company)
Address (street, No.)
Address (post or ZIP code, city) (country)

⁴⁸ Where applicable

The EU Declaration of Conformity was issued in/on:

Place, date

.....⁴⁹⁾.....

Name
Function
Company
Address

⁴⁹ A signed, legally binding EU Declaration of Conformity is supplied with the product.

Index

A

Abrasive fluids 52
Applications 10

B

Bearing temperature monitoring 44
Bearings 20

C

Certificate of Decontamination 150
Commissioning 48

D

Design 20
Designation 19
Dismantling 69
Disposal 18
Drive 20

E

Electrical connection 46
Electromagnetic compatibility 40
Event of damage 8
 Ordering spare parts 93
Explosion protection 12, 24, 26, 27, 39, 40, 41, 42, 44,
46, 47, 49, 50, 51, 54, 56, 63, 76

F

Faults
 Causes and remedies 95
Fluid handled
 Density 51

G

Grease lubrication
 Grease quality 67

I

Impeller type 20
Installation 24
Intended use 10
Interference immunity 41

K

Key to safety symbols/markings 9

L

Leakage monitoring 43
Level control 40
Lubricant 63
 Flow rate 64
 Quality 63

M

Mechanical seal leakage 44

O

Oil lubrication
 Oil quality 63
Operation on a frequency inverter 40, 50
Order number 8
Other applicable documents 8
Overload protection 39

P

Partly completed machinery 8
Preservation 16
Product description 19

R

Reassembly 69
Return to supplier 18
Returning to service 53

S

Safety 10
Safety awareness 11
Scope of supply 23
Sensors 41
Shaft seal 20
Shutdown 53
Spare part
 Ordering spare parts 93
Spare parts stock 93
Start-up 49
Storage 16, 53

T

Tightening torques 92

W

Warnings 9
Warranty claims 8



KSB SE & Co. KGaA

Johann-Klein-Straße 9 • 67227 Frankenthal (Germany)

Tel. +49 6233 86-0

www.ksb.com

KSB SE & Co. KGaA

Turmstraße 92 • 06110 Halle (Germany)

Tel. +49 345 4826-0

www.ksb.com

