

Submersible Pump in Discharge Tube

## Amacan K

50 Hz

### General Arrangement Drawings

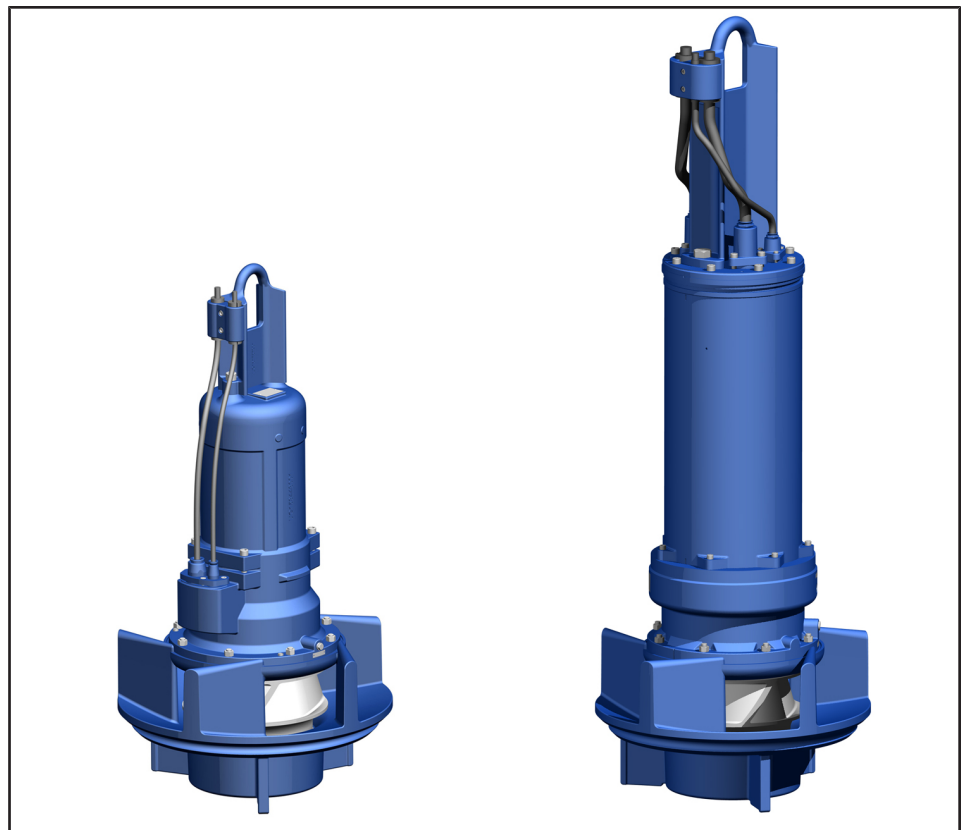

## **Legal information/Copyright**

General Arrangement Drawings Amacan K

All rights reserved. The contents provided herein must neither be distributed, copied, reproduced, edited or processed for any other purpose, nor otherwise transmitted, published or made available to a third party without the manufacturer's express written consent.

Subject to technical modification without prior notice.

© KSB SE & Co. KGaA, Frankenthal 09/02/2018

---

## Contents

<b>Water Applications: Water Transport .....</b>	<b>4</b>
Submersible Pump in Discharge Tube.....	4
Amacan K.....	4
Designation .....	4
Selection information .....	4
Types of installation.....	5
General arrangement drawings.....	6
Installation type BU, motor version UE, XE, YE.....	6
Installation type BU, motor version UN, XN, YN.....	8
Installation type CU, motor version UE, XE, YE.....	10
Installation type CU, motor version UN, XN, YN.....	13
Installation type DU, motor version UE, XE, YE .....	16
Installation type DU, motor version UN, XN, YN.....	19

## Water Applications: Water Transport

### Submersible Pump in Discharge Tube

## Amacan K

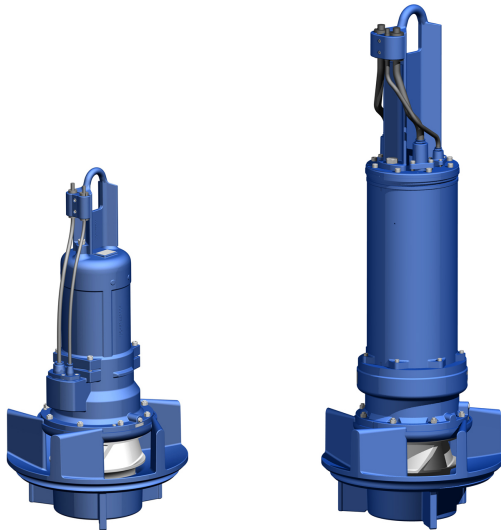

### Designation

Example: Amacan K 800-400 / 60 6 UN G - IE3

Designation key

Code	Description	
Amacan	Type series	
K	Impeller type	
	K	Channel impeller
800	Nominal diameter of the discharge tube [mm]	
400	Nominal impeller diameter [mm]	
60	Motor size	
6	Number of motor poles	
	2, 4, 6, 8, 10	
UN	Motor version	
	UN/UE	Without explosion protection, for fluid temperatures of up to 40 °C
	XN/XE	Explosion protection $\text{Ex d IIB T3}$ , for fluid temperatures of up to 40 °C
	YN/YE	Explosion protection $\text{Ex d IIB T4}$ , for fluid temperatures of up to 40 °C
G	Material variant	
	G	Impeller made of grey cast iron, standard design
	G1	Like G, with impeller made of duplex stainless steel
IE3	Motor efficiency classification <sup>1)</sup>	
	<sup>2)</sup>	No efficiency classification
	IE2	High Efficiency
	IE3	Premium Efficiency

### Selection information

#### Information for pump selection

The guaranteed point of submersible pumps in discharge tubes is measured at a head 0.5 m above the motor (DIN 1184). The documented characteristic curves refer to this data. This must be taken into account when calculating system losses. The indicated heads and performance data apply to pumped fluids with a density  $\rho = 1 \text{ kg/dm}^3$  and a kinematic viscosity  $\nu$  of up to  $20 \text{ mm}^2/\text{s}$ .

- Adjust the power input to the density of the fluid handled:  
 $P_2 \text{ (required)} = \rho \text{ [kg/dm}^3\text{]} \text{ (fluid handled)} \times P_2 \text{ (documented)}$
- Select the operating point with the largest power input within an operating range. Select a motor size providing a power reserve to compensate the tolerances in the system characteristic / pump characteristic.

Recommended motor power reserve<sup>3)</sup>

$P_2$ [kW]	Reserve	
	Mains operation	With frequency inverter
$\leq 30$	10 %	15 %
$> 30$	5 %	10 %

Determine the min. water level  $t_{1\text{min}}$  (see diagram in general arrangement drawing):

The min. water level  $t_{1\text{min}}$  is the water level required in the pump's suction chamber to ensure the following:

- The liquid cover above the hydraulic system (impeller) is sufficient. (Shown in diagram depending on pump size.)
- The pump does not draw in air-entraining vortices. (Shown in diagram depending on flow rate.)
- No cavitation occurs in the hydraulic system. (Check against the  $\text{NPSH}_{\text{required}}$  value indicated in the technical literature). The following conditions must be met:
  - $\text{NPSH}_{\text{available}} > \text{NPSH}_{\text{required}} + \text{safety allowance}$
  - $\text{NPSH}_{\text{available}} = 10.0 + (t_1 - t_2)$
  - Safety allowance:  
 up to  $Q_{\text{opt}} \Rightarrow 0.5 \text{ m}$   
 greater than  $Q_{\text{opt}} \Rightarrow 1.0 \text{ m}$

#### Head (H)

The total pump head is composed as follows:

$$H = H_{\text{geo}} + \Delta H_v$$

$H_{\text{geo}}$  (static head)

- Without discharge elbow: difference between the suction-side water level and the overflow edge
- With discharge elbow: difference between suction-side and discharge-side water level

$\Delta H_v$  (losses in the system)

- Starting 0.5 m downstream of the pump: e.g. pipe friction, elbow, swing check valve, etc.

1) IEC 60034-30 standard not binding for submersible motor pumps. Efficiencies calculated/determined according to the measurement method specified in IEC 60034-2. The marking is used for submersible motors that achieve efficiency levels similar to those of standardised motors acc. to the IEC 60034-30 standard.

2) Blank

3) If larger power reserves are stipulated by local regulations, these larger reserves must be provided.

**Inlet losses, riser losses and elbow losses**

Losses are caused by the inlet, riser and elbow (and/or free discharge).

- Losses in the riser up to the indicated reference level (0.5 m above the motor) are taken into account in the documented characteristic curves.

- Inlet and elbow losses are system losses. These losses must be taken into account for selection.
- Information on structural requirements, pump installation and pump sump design is given in the KSB know-how brochure "Planning information: Amacan submersible pumps in discharge tubes" (0118.55).

**Types of installation**

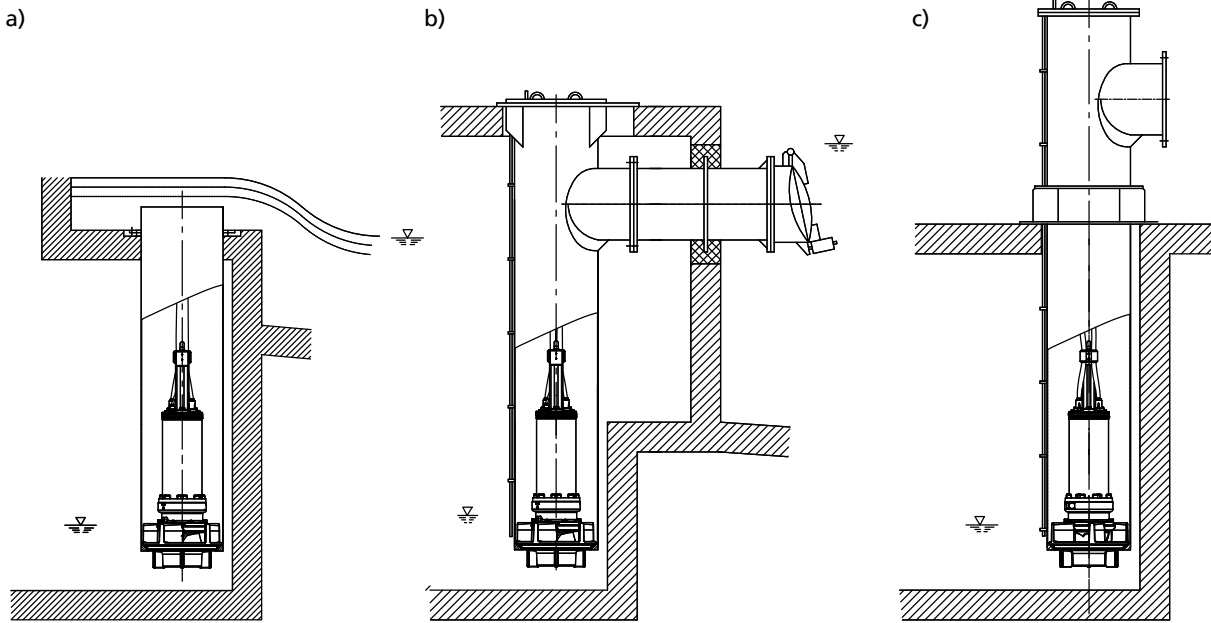

**Fig. 1:** Overview of installation types a) Installation type BU (overflow design) b) Installation type CU (underfloor discharge) c) Installation type DU (above-floor discharge nozzle)

General arrangement drawings

Installation type BU, motor version UE, XE, YE

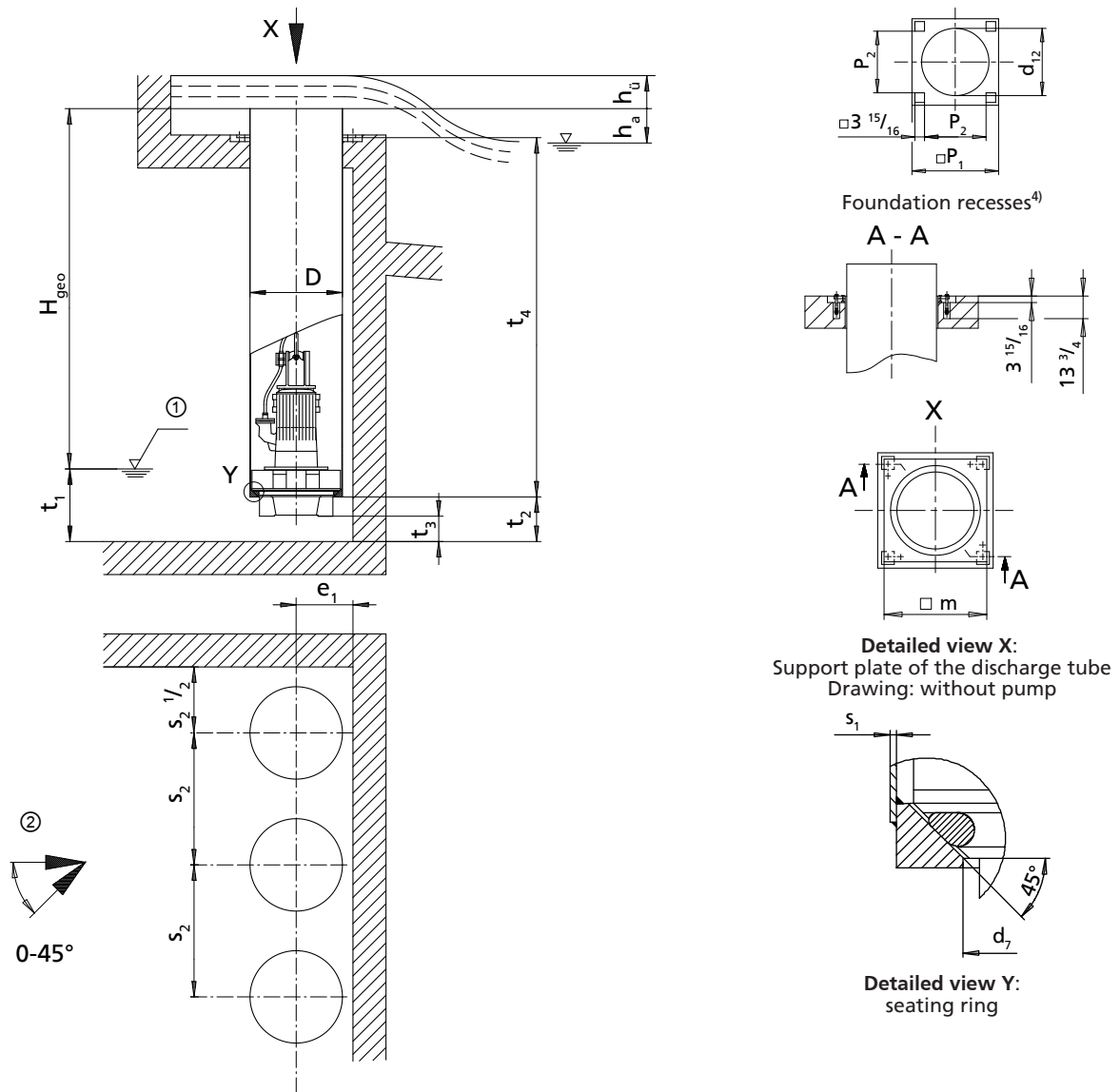

- ①: Minimum water level (see diagram on the following page)
- ②: Approach flow

Dimensions [mm]

Size	D	d <sub>7</sub>	d <sub>12</sub>	e <sub>r</sub> <sup>5)</sup>	h <sub>a</sub>	m	p <sub>1</sub>	p <sub>2</sub>	s <sub>1 min</sub>	s <sub>2 min</sub>	t <sub>2</sub> <sup>5)</sup>	t <sub>3</sub>	t <sub>4 min</sub> <sup>6)</sup>
700-324	711	570	750	430	100	800	900	640	8	1150	330	200	1500
700-330	711	570	750	430	100	800	900	640	8	1150	330	200	1500
700-371	711	570	750	430	100	800	900	640	8	1150	330	200	1500
800-324	813	570	850	480	100	910	1000	740	8	1150	330	200	1500
800-330	813	570	850	480	100	910	1000	740	8	1150	330	200	1650
800-370	813	656	850	480	100	910	1000	740	8	1150	330	200	1550
800-371	813	570	850	480	100	910	1000	740	8	1150	330	200	1500
800-400	813	656	850	480	100	910	1000	740	8	1400	410	250	1700
800-401	813	656	850	480	100	910	1000	740	8	1400	410	250	1700

Permissible deviations:

- 4) All dimensions for foundation recesses apply to discharge tube design without intermediate flange.
- 5) Observe this dimension.
- 6) Value for maximum motor length

- Tolerances in building construction to DIN 18202, Part 4, Group B
- Welded design: B/F to DIN EN ISO 13920
- Tolerances for conical seat (detailed view Y): ISO 2768-mH

**Loss diagram**

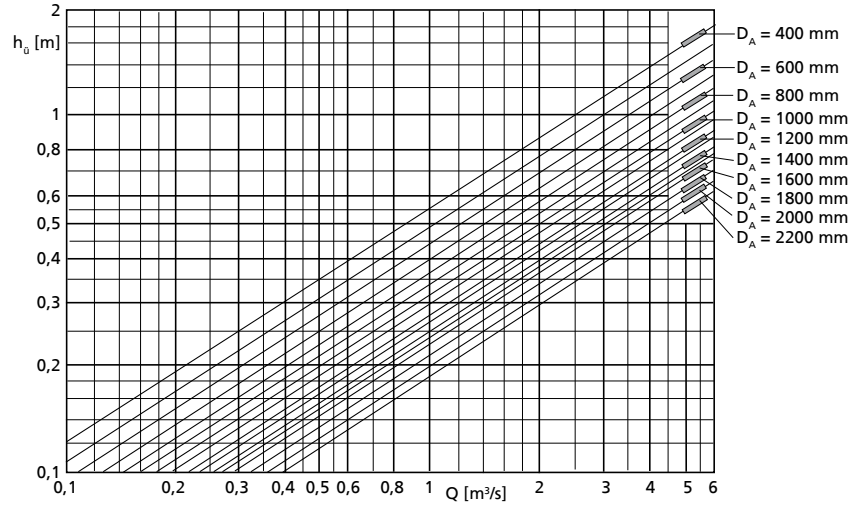
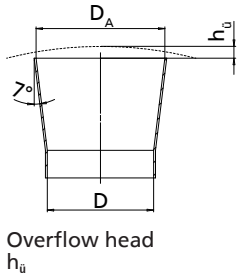

**Calculation formulas:**

$$H = H_{geo} + \Delta H_v$$

$\Delta H_v$

- Overflow head  $h_u$  (see diagram)
- Loss in the riser (pipe friction)
- Outlet loss  $v^2/2g$  ( $v$  refers to  $D_A$ )

Overflow head  $h_u$  depends on  $Q$  and the discharge diameter  $D_A$ . The characteristic curve values only apply to unimpeded outlet in all directions; otherwise they are approximate values only.

**Minimum water level diagram**

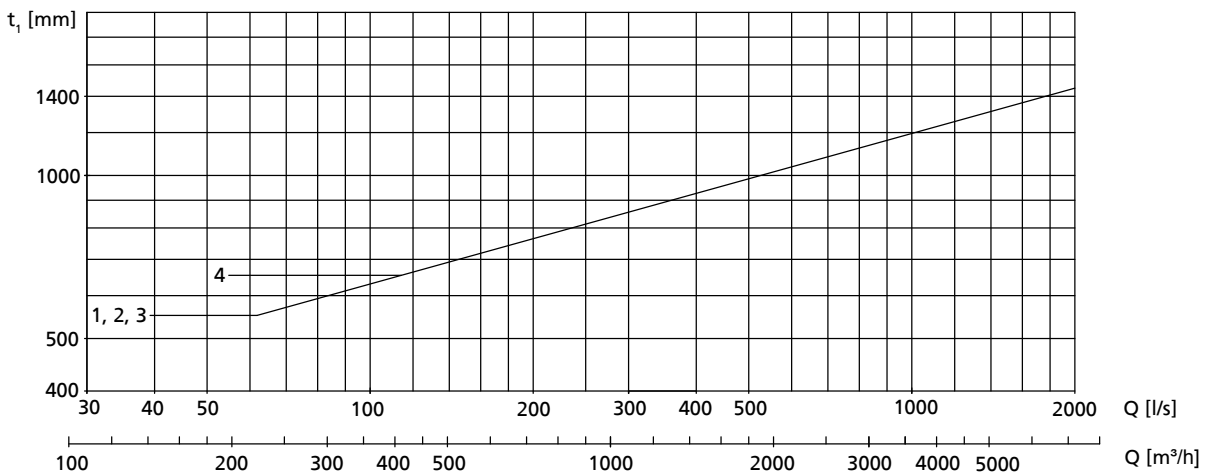
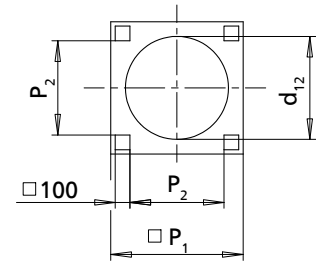
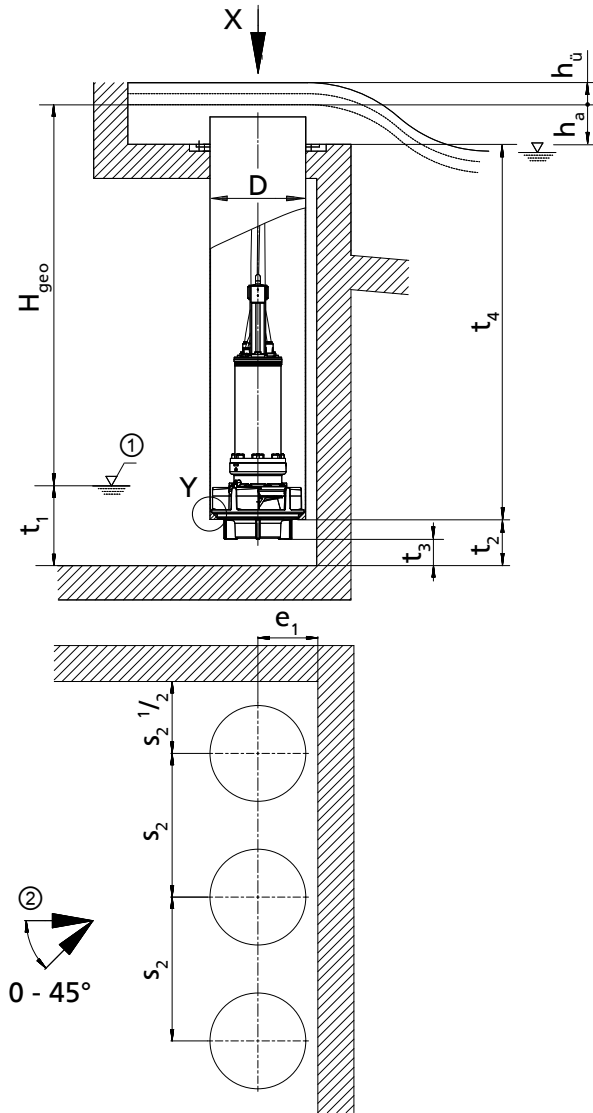

Fig. 2: Minimum water level diagram, motor version UE, XE, YE

1	Amacan K 700-330, 800-330
2	Amacan K 700-324, 700-371, 800-324, 800-371
3	Amacan K 800-370
4	Amacan K 800-400, 800-401

Installation type BU, motor version UN, XN, YN



Foundation recesses<sup>7)</sup>

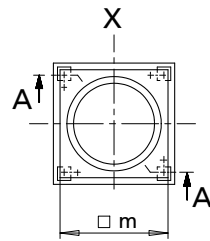
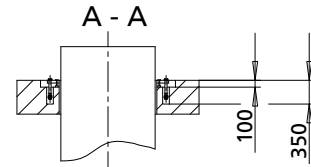

Detailed view X:  
Support plate of the discharge tube  
Drawing: without pump

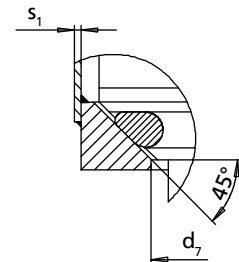

Detailed view Y:  
seating ring

- ①: Minimum water level (see diagram on the following page)
- ②: Approach flow

Dimensions [mm]

Size	D	d <sub>7</sub>	d <sub>12</sub>	e <sub>1</sub> <sup>8)</sup>	h <sub>a</sub>	m	p <sub>1</sub>	p <sub>2</sub>	s <sub>1 min</sub>	s <sub>2 min</sub>	t <sub>2</sub> <sup>8)</sup>	t <sub>3</sub>	t <sub>4 min</sub> <sup>9)</sup>
700-330	711	570	750	430	100	800	900	640	8	1150	330	200	2400
800-400	813	656	850	480	100	910	1000	740	8	1400	410	250	2450
800-401	813	656	850	480	100	910	1000	740	8	1400	410	250	2450
1000-420	1016	856	1070	600	100	1150	1220	960	10	1600	435	250	2650
1000-421	1016	856	1070	600	100	1150	1220	960	10	1600	435	250	2650
1000-500	1016	856	1070	600	100	1150	1220	960	10	1800	480	300	2900
1200-630	1220	1015	1280	700	100	1360	1420	1160	12	2250	585	350	3450

Permissible deviations:

- Tolerances in building construction to DIN 18202, Part 4, Group B
- Welded design: B/F to DIN EN ISO 13920
- Tolerances for conical seat (detailed view Y): ISO 2768-mH

7) All dimensions for foundation recesses apply to discharge tube design without intermediate flange.  
8) Observe this dimension.  
9) Value for maximum motor length



Loss diagram

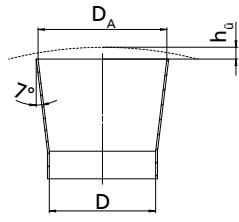

Overflow head  $h_u$

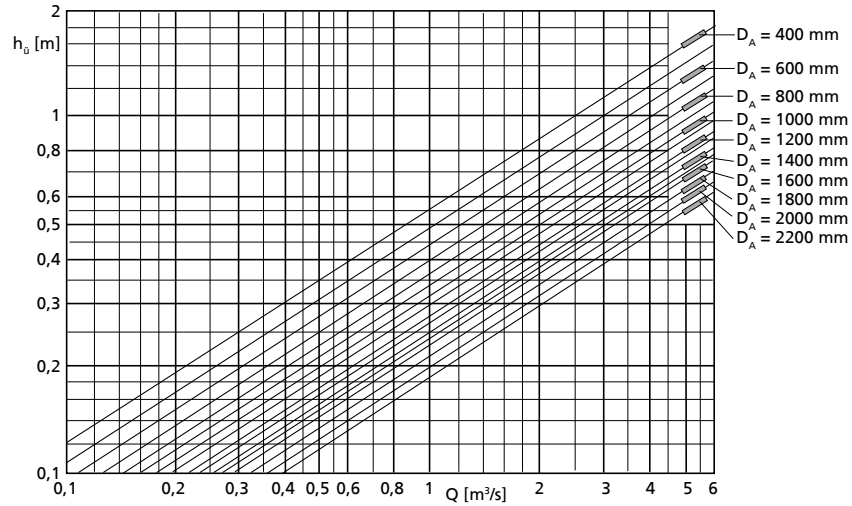

Loss diagram

Calculation formulas:

$$H = H_{geo} + \Delta H_v$$

$\Delta H_v$

- Overflow head  $h_u$  (see diagram)
- Loss in the riser (pipe friction)
- Outlet loss  $v^2/2g$  ( $v$  refers to  $D_A$ )

Overflow head  $h_u$  depends on  $Q$  and the discharge diameter  $D_A$ . The characteristic curve values only apply to unimpeded outlet in all directions; otherwise they are approximate values only.

Minimum water level diagram

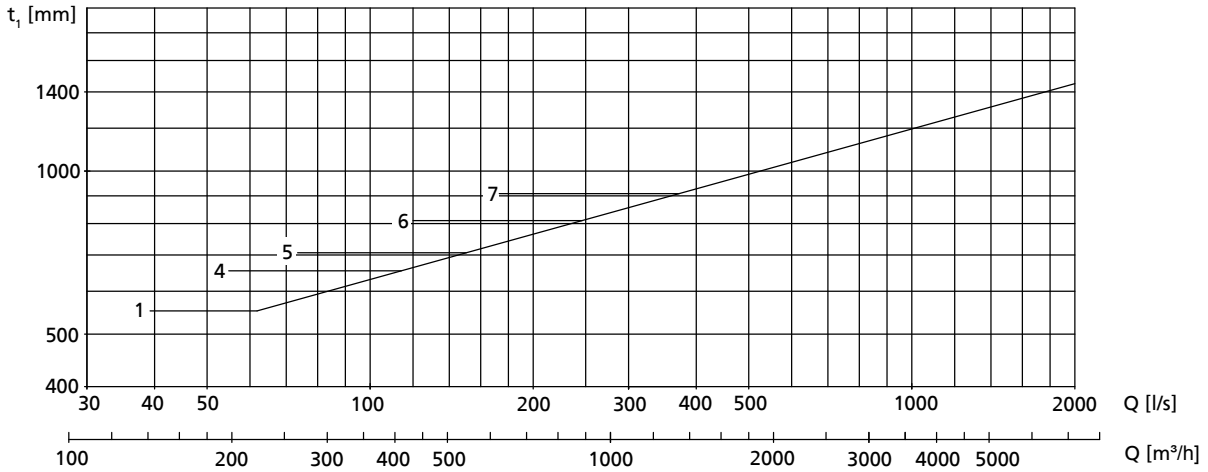
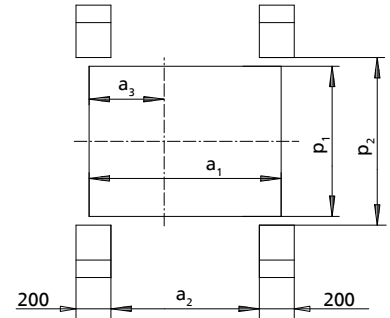
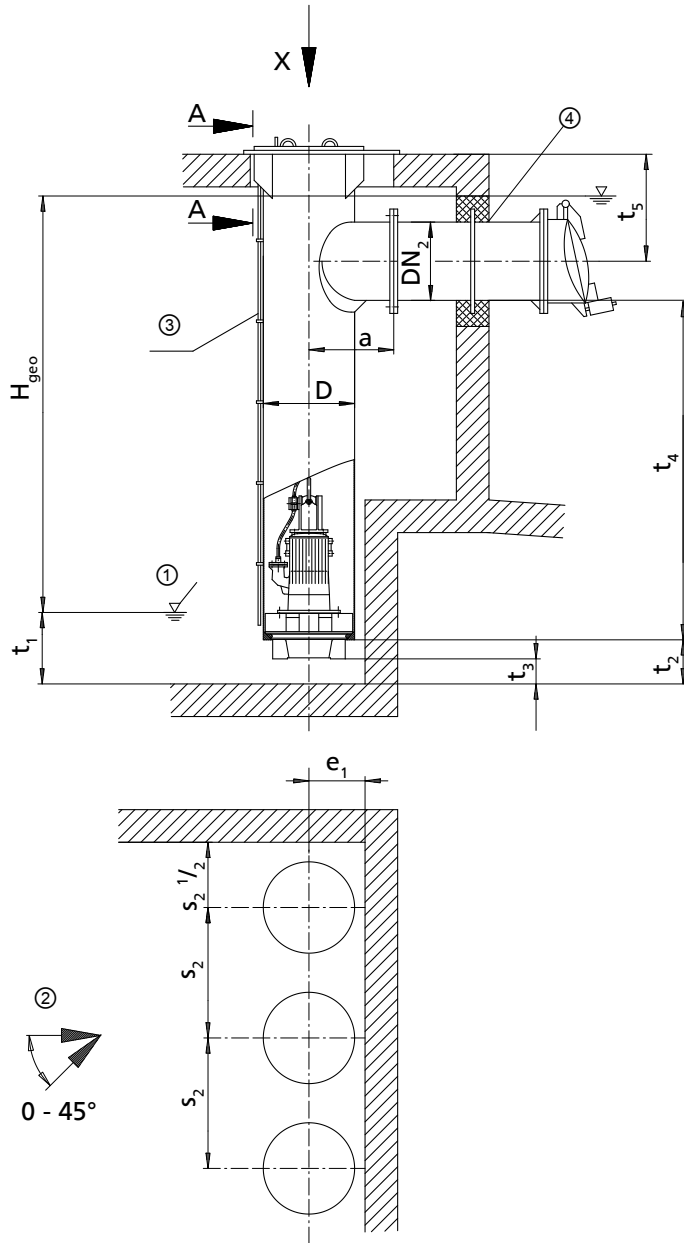

Fig. 3: Minimum water level diagram, motor version UN, XN, YN

1	Amacan K 700-330
4	Amacan K 800-400, 800-401
5	Amacan K 1000-420, 1000-421
6	Amacan K 1000-500
7	Amacan K 1200-630

Installation type CU, motor version UE, XE, YE



Foundation recesses<sup>10)</sup>

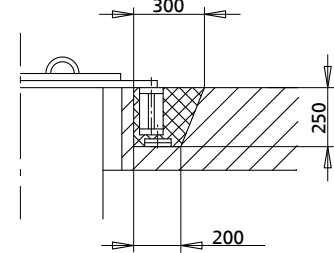

Section A - A:

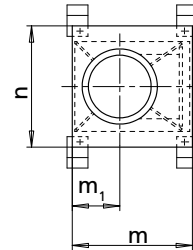

Detailed view X:  
Support plate of the discharge tube  
Drawing: without pump

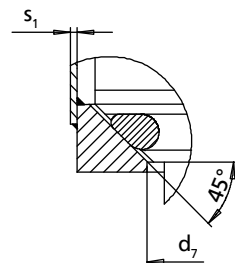

Detailed view Y:  
seating ring



- ①: Minimum water level (see diagram on the following page)
- ②: Approach flow
- ③: Vent line
- ④: Connect the discharge pipe to the discharge tube without transmitting any stresses or strains.

Dimensions [mm]

Size	D	DN <sub>2 min</sub>	DN <sub>2 max</sub>	a	a <sub>1</sub> <sup>11)</sup>	a <sub>2</sub> <sup>11)</sup>	a <sub>3</sub> <sup>11)</sup>	d <sub>7</sub>	e <sub>1</sub> <sup>12)</sup>	m <sup>11)</sup>	m <sub>1</sub> <sup>11)</sup>	n <sup>11)</sup>
700-324	711	300	600	650	1120	870	430	570	430	1170	455	1160
700-330	711	300	600	650	1120	870	430	570	430	1170	455	1160
700-371	711	300	600	650	1120	870	430	570	430	1170	455	1160
800-324	813	400	700	700	1220	970	480	570	480	1270	505	1260
800-330	813	400	700	700	1220	970	480	570	480	1270	505	1260
800-370	813	400	700	700	1220	970	480	656	480	1270	505	1260
800-371	813	400	700	700	1220	970	480	570	480	1270	505	1260
800-400	813	400	700	700	1220	970	480	656	480	1270	505	1260
800-401	813	400	700	700	1220	970	480	656	480	1270	505	1260

- 10) All dimensions for foundation recesses apply to discharge tube design without intermediate flange.
- 11) Designed for DN<sub>2 max</sub>
- 12) Observe this dimension.

Dimensions [mm]

Size	p <sub>1</sub> <sup>11)</sup>	p <sub>2</sub> <sup>11)</sup>	s <sub>1 min</sub>	s <sub>2 min</sub>	t <sub>2</sub> <sup>12)</sup>	t <sub>3</sub>	t <sub>4 min</sub> <sup>13)</sup>	t <sub>5 min</sub> <sup>11)</sup>
700-324	860	960	8	1150	330	200	1550	720
700-330	860	960	8	1150	330	200	1550	720
700-371	860	960	8	1150	330	200	1550	720
800-324	960	1060	8	1150	330	200	1550	770
800-330	960	1060	8	1150	330	200	1700	770
800-370	960	1060	8	1150	330	200	1600	770
800-371	960	1060	8	1150	330	200	1550	770
800-400	960	1060	8	1400	410	250	1700	770
800-401	960	1060	8	1400	410	250	1750	770

Permissible deviations:

- Tolerances in building construction to DIN 18202, Part 4, Group B
- Welded design: B/F to DIN EN ISO 13920
- Tolerances for conical seat (detailed view Y): ISO 2768-mH
- Discharge flanges to DIN EN 1092-1 PN6 / DIN EN 1092-2 PN6

Loss diagram

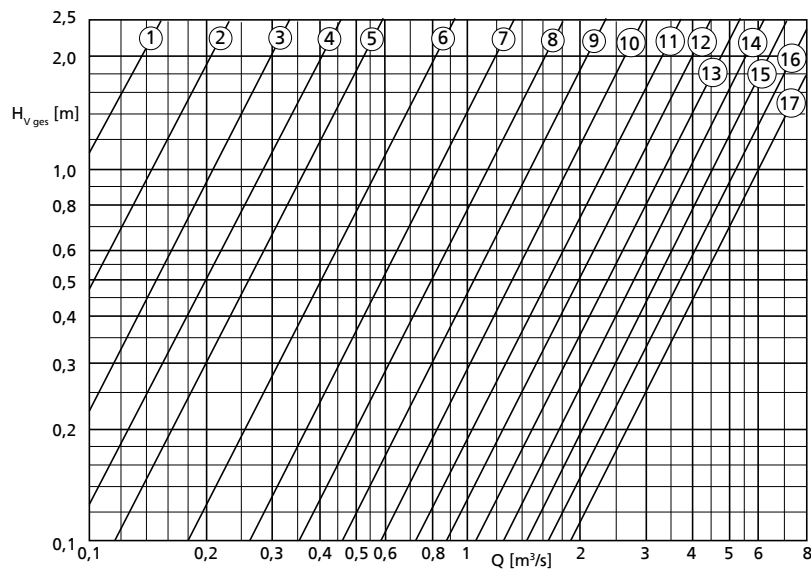

- ① - DN<sub>2</sub> = 200 mm
- ② - DN<sub>2</sub> = 250 mm
- ③ - DN<sub>2</sub> = 300 mm
- ④ - DN<sub>2</sub> = 350 mm
- ⑤ - DN<sub>2</sub> = 400 mm
- ⑥ - DN<sub>2</sub> = 500 mm
- ⑦ - DN<sub>2</sub> = 600 mm
- ⑧ - DN<sub>2</sub> = 700 mm
- ⑨ - DN<sub>2</sub> = 800 mm
- ⑩ - DN<sub>2</sub> = 900 mm
- ⑪ - DN<sub>2</sub> = 1000 mm
- ⑫ - DN<sub>2</sub> = 1100 mm
- ⑬ - DN<sub>2</sub> = 1200 mm
- ⑭ - DN<sub>2</sub> = 1300 mm
- ⑮ - DN<sub>2</sub> = 1400 mm
- ⑯ - DN<sub>2</sub> = 1500 mm
- ⑰ - DN<sub>2</sub> = 1600 mm

Calculation formulas:

$$H = H_{geo} + \Delta H_v$$

$$\Delta H_v$$

- Loss in the riser (pipe friction)
- H<sub>v ges.</sub> (see diagram)

H<sub>v ges.</sub> comprises:

- Elbow
- Discharge pipe length = 5 x DN<sub>2</sub>
- Swing check valve
- Outlet losses v<sup>2</sup>/2g

13) Value for maximum motor length

Minimum water level diagram

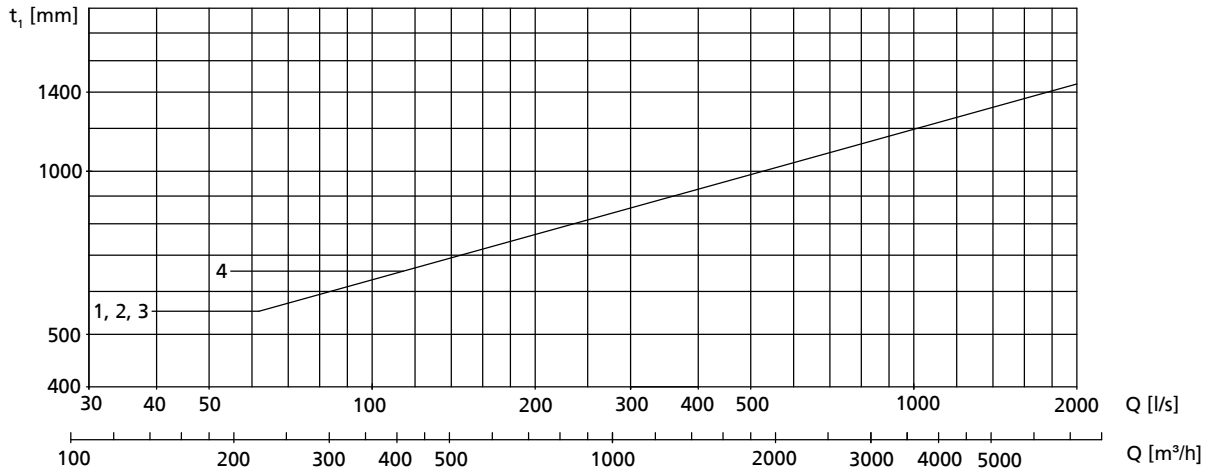
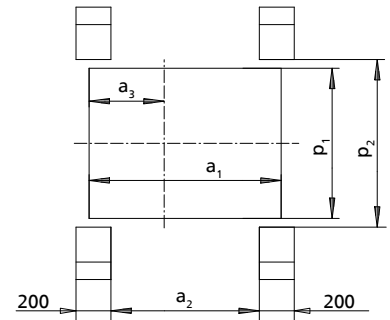
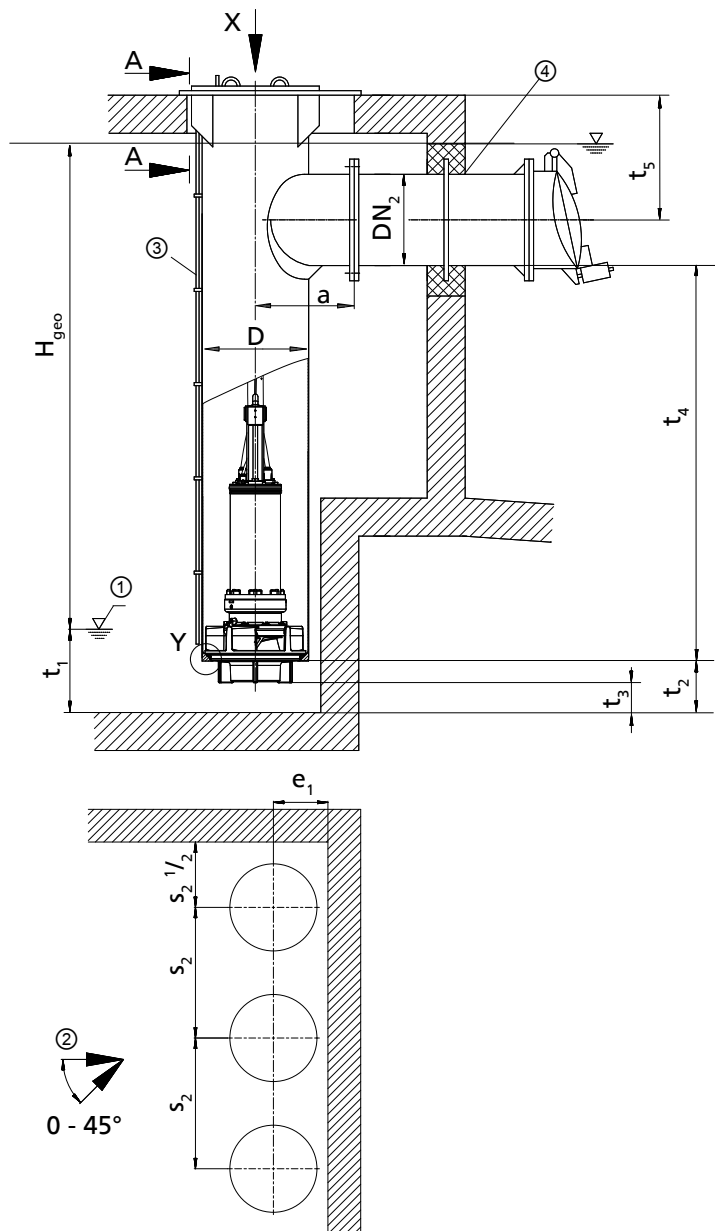

Fig. 4: Minimum water level diagram, motor version UE, XE, YE

1	Amacan K 700-330, 800-330
2	Amacan K 700-324, 700-371, 800-324, 800-371
3	Amacan K 800-370
4	Amacan K 800-400, 800-401

Installation type CU, motor version UN, XN, YN



Foundation recesses<sup>14)</sup>

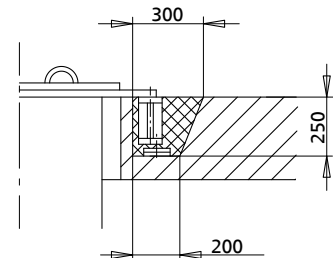

Section A - A:

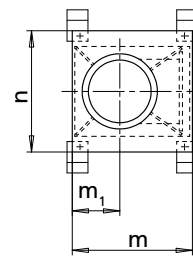

Detailed view X:  
Support plate of the discharge tube  
Drawing: without pump

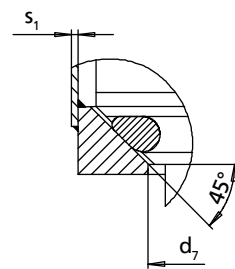

Detailed view Y:  
seating ring

- ①: Minimum water level (see diagram on the following page)
- ②: Approach flow
- ③: Vent line
- ④: Connect the discharge pipe to the discharge tube without transmitting any stresses or strains.

Dimensions [mm]

Size	D	DN <sub>2 min</sub>	DN <sub>2 max</sub>	a	a <sub>1</sub> <sup>15)</sup>	a <sub>2</sub> <sup>15)</sup>	a <sub>3</sub> <sup>15)</sup>	d <sub>7</sub>	e <sub>1</sub> <sup>16)</sup>	m <sup>15)</sup>	m <sub>1</sub> <sup>15)</sup>	n <sup>15)</sup>
700-330	711	300	600	650	1120	870	430	570	430	1170	455	1160
800-400	813	400	700	700	1220	970	480	656	480	1270	505	1260
800-401	813	400	700	700	1220	970	480	656	480	1270	505	1260
1000-420	1016	600	900	810	1430	1160	580	856	600	1520	625	1480
1000-421	1016	600	900	810	1430	1160	580	856	600	1520	625	1480
1000-500	1016	600	900	810	1430	1160	580	856	600	1520	625	1480
1200-630	1220	900	1200	910	1630	1360	680	1015	700	1720	725	1850

14) All dimensions for foundation recesses apply to discharge tube design without intermediate flange.  
15) Designed for DN<sub>2 max</sub>  
16) Observe this dimension.

Dimensions [mm]

Size	p <sub>1</sub> <sup>15)</sup>	p <sub>2</sub> <sup>15)</sup>	s <sub>1 min</sub>	s <sub>2 min</sub>	t <sub>2</sub> <sup>16)</sup>	t <sub>3</sub>	t <sub>4 min</sub> <sup>17)</sup>	t <sub>5 min</sub> <sup>15)</sup>
700-330	860	960	8	1150	330	200	2450	720
800-400	960	1060	8	1400	410	250	2500	770
800-401	960	1060	8	1400	410	250	2500	770
1000-420	1180	1280	10	1600	435	250	2700	925
1000-421	1180	1280	10	1600	435	250	2700	925
1000-500	1180	1280	10	1800	480	300	2950	925
1200-630	1510	1610	12	2250	585	350	3500	1100

Permissible deviations:

- Tolerances in building construction to DIN 18202, Part 4, Group B
- Welded design: B/F to DIN EN ISO 13920
- Tolerances for conical seat (detailed view Y): ISO 2768-mH
- Discharge flanges to DIN EN 1092-1 PN6 / DIN EN 1092-2 PN6

Loss diagram

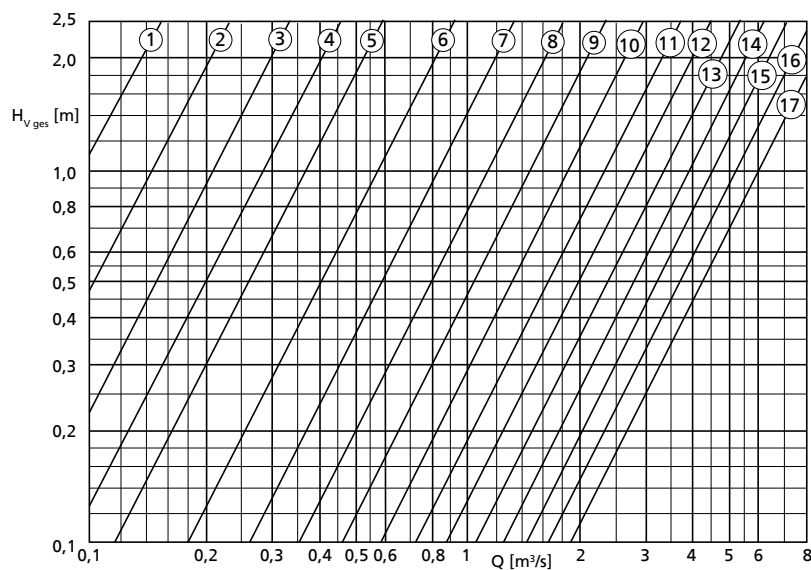

- ① - DN<sub>2</sub> = 200 mm
- ② - DN<sub>2</sub> = 250 mm
- ③ - DN<sub>2</sub> = 300 mm
- ④ - DN<sub>2</sub> = 350 mm
- ⑤ - DN<sub>2</sub> = 400 mm
- ⑥ - DN<sub>2</sub> = 500 mm
- ⑦ - DN<sub>2</sub> = 600 mm
- ⑧ - DN<sub>2</sub> = 700 mm
- ⑨ - DN<sub>2</sub> = 800 mm
- ⑩ - DN<sub>2</sub> = 900 mm
- ⑪ - DN<sub>2</sub> = 1000 mm
- ⑫ - DN<sub>2</sub> = 1100 mm
- ⑬ - DN<sub>2</sub> = 1200 mm
- ⑭ - DN<sub>2</sub> = 1300 mm
- ⑮ - DN<sub>2</sub> = 1400 mm
- ⑯ - DN<sub>2</sub> = 1500 mm
- ⑰ - DN<sub>2</sub> = 1600 mm

Calculation formulas:

$$H = H_{\text{geo}} + \Delta H_v$$

$$\Delta H_v$$

- Loss in the riser (pipe friction)
- H<sub>v ges.</sub> (see diagram)

H<sub>v ges.</sub> comprises:

- Elbow
- Discharge pipe length = 5 x DN<sub>2</sub>
- Swing check valve
- Outlet losses v<sup>2</sup>/2g

17) Value for maximum motor length

Minimum water level diagram

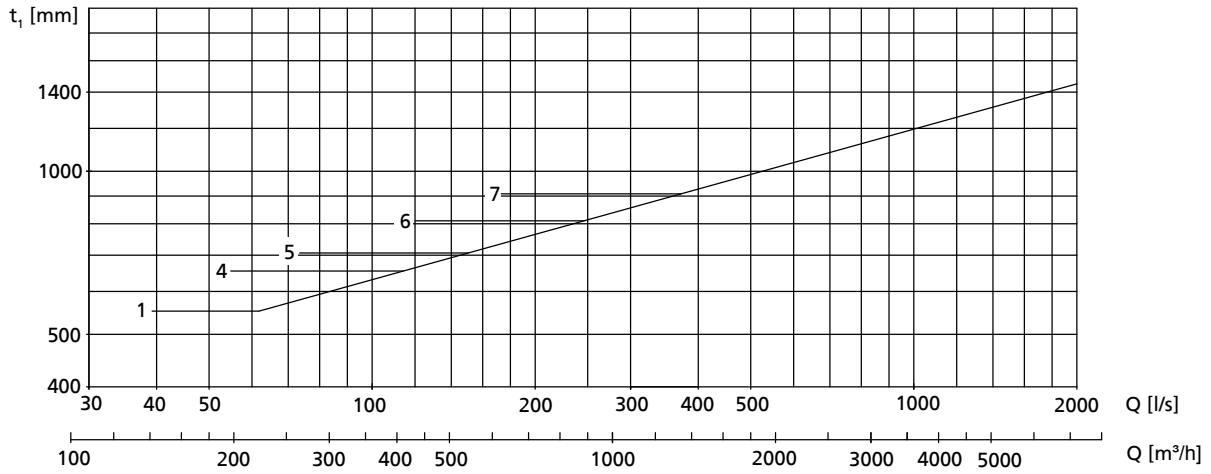
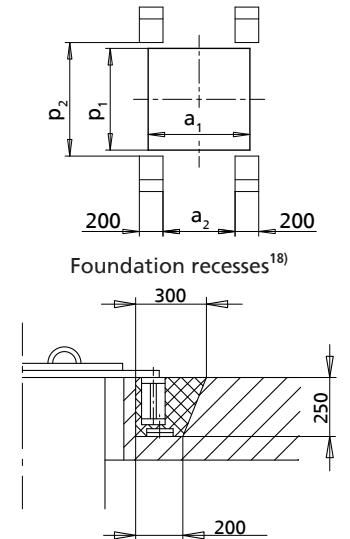
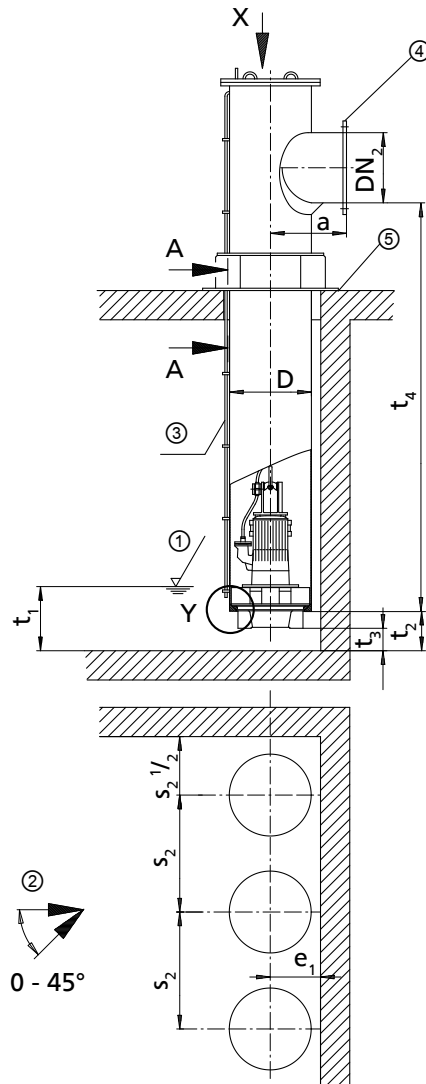

Fig. 5: Minimum water level diagram, motor version UN, XN, YN

1	Amacan K 700-330
4	Amacan K 800-400, 800-401
5	Amacan K 1000-420, 1000-421
6	Amacan K 1000-500
7	Amacan K 1200-630

Installation type DU, motor version UE, XE, YE



Foundation recesses<sup>18)</sup>

Section A - A:

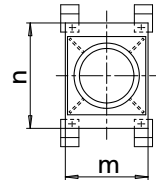

Detailed view X:  
Support plate of the discharge tube  
Drawing: without pump

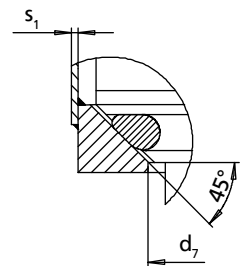

Detailed view Y:  
seating ring

- ①: Minimum water level (see diagram on the following page)
- ②: Approach flow
- ③: Vent line
- ④: Connect the discharge pipe to the discharge tube without transmitting any stresses or strains.
- ⑤: Not pressure-proof

Dimensions [mm]

Size	D	DN <sub>2 min</sub>	DN <sub>2 max</sub>	a	a <sub>1</sub>	a <sub>2</sub>	d <sub>7</sub>	e <sub>1</sub> <sup>19)</sup>	m	n
700-324	711	300	600	650	860	610	570	430	930	1160
700-330	711	300	600	650	860	610	570	430	930	1160
700-371	711	300	600	650	860	610	570	430	930	1160
800-324	813	400	700	700	960	710	570	480	1030	1260
800-330	813	400	700	700	960	710	570	480	1030	1260
800-370	813	400	700	700	960	710	656	480	1030	1260
800-371	813	400	700	700	960	710	570	480	1030	1260
800-400	813	400	700	700	960	710	656	480	1030	1260
800-401	813	400	700	700	960	710	656	480	1030	1260

18) All dimensions for foundation recesses apply to discharge tube design without intermediate flange.

19) Observe this dimension.

20) Value for maximum motor length



Dimensions [mm]

Size	p <sub>1</sub>	p <sub>2</sub>	s <sub>1 min</sub>	s <sub>2 min</sub>	t <sub>2</sub> <sup>19)</sup>	t <sub>3</sub>	t <sub>4 min</sub> <sup>20)</sup>
700-324	860	960	8	1150	330	200	1550
700-330	860	960	8	1150	330	200	1550
700-371	860	960	8	1150	330	200	1550
800-324	960	1060	8	1150	330	200	1550
800-330	960	1060	8	1150	330	200	1700
800-370	960	1060	8	1150	330	200	1600
800-371	960	1060	8	1150	330	200	1550
800-400	960	1060	8	1400	410	250	1750
800-401	960	1060	8	1400	410	250	1750

Permissible deviations:

- Tolerances in building construction to DIN 18202, Part 4, Group B
- Welded design: B/F to DIN EN ISO 13920
- Tolerances for conical seat (detailed view Y): ISO 2768-mH
- Discharge flanges to DIN EN 1092-1 PN6 / DIN EN 1092-2 PN6

Loss diagram

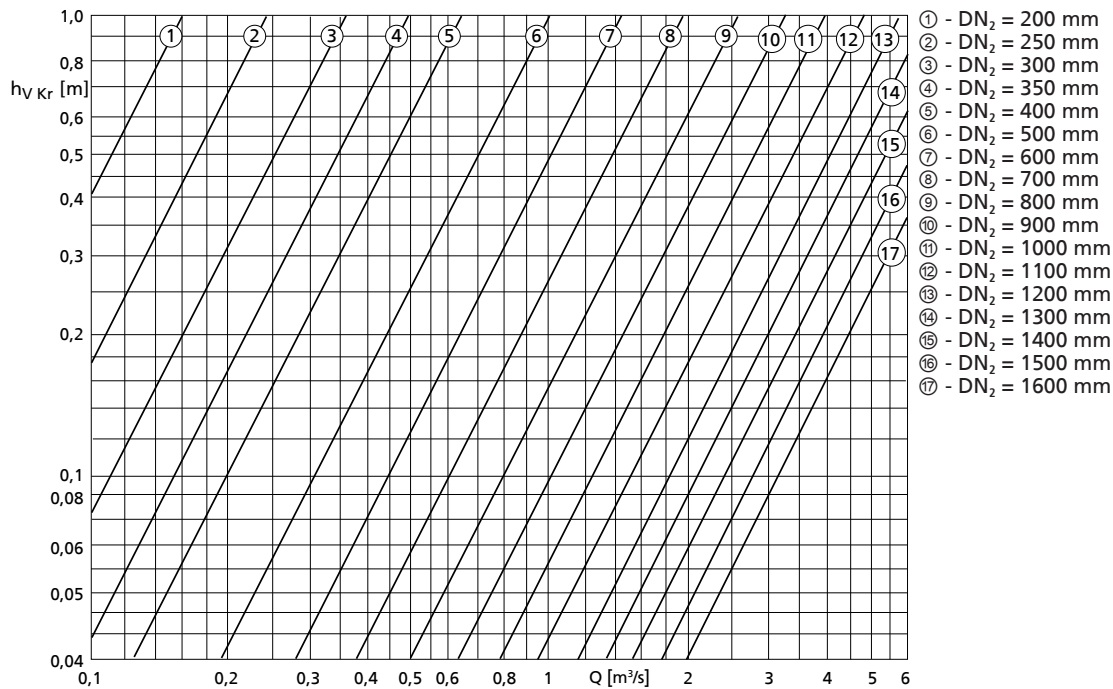

Calculation formulas:

$$H = H_{\text{geo}} + \Delta H_v$$

$$\Delta H_v$$

- Loss in the elbow  $h_{vKr}$  (see diagram)
- Loss in the riser (pipe friction)
- $H_{V \text{ system}}$  (valves, etc.)

$H_{V \text{ system}}$  must be determined for the specific system.

Minimum water level diagram

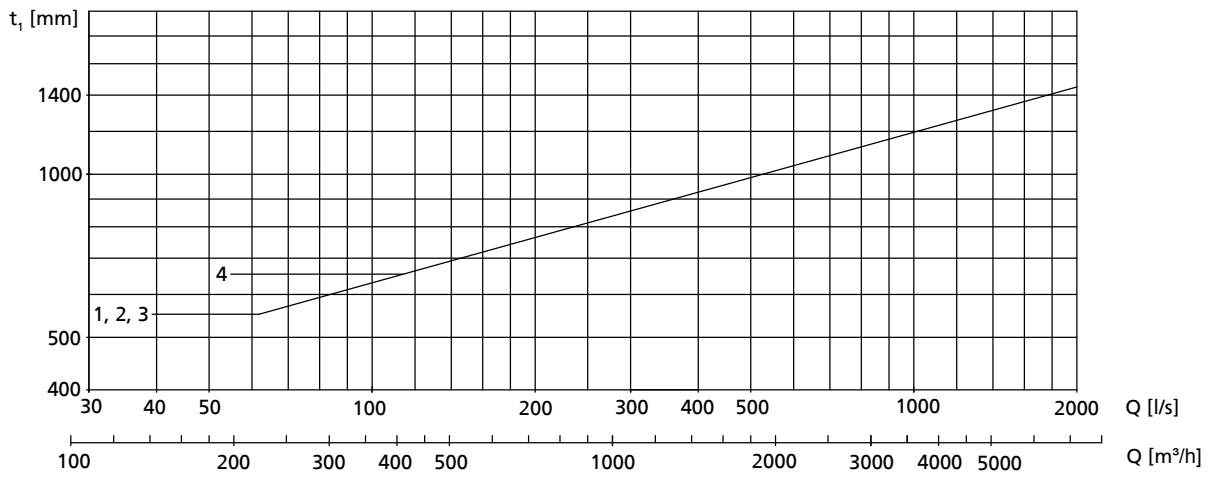
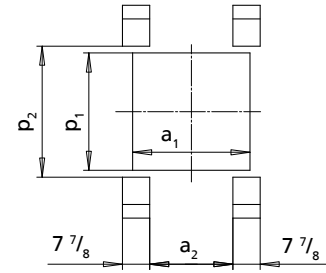
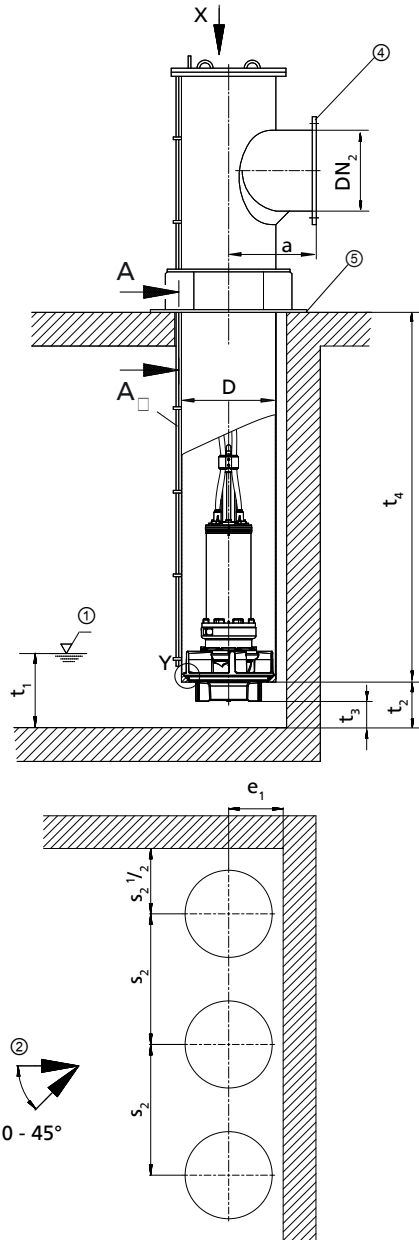

Fig. 6: Minimum water level diagram, motor version UE, XE, YE

1	Amacan K 700-330, 800-330
2	Amacan K 700-324, 700-371, 800-324, 800-371
3	Amacan K 800-370
4	Amacan K 800-400, 800-401

Installation type DU, motor version UN, XN, YN



Foundation recesses<sup>21)</sup>

A - A

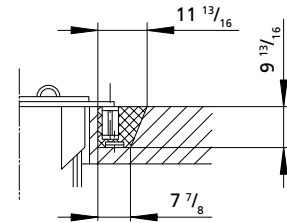

Section A - A:

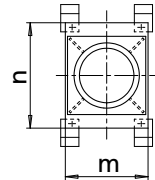

Detailed view X:  
Support plate of the discharge tube  
Drawing: without pump

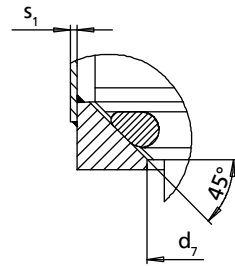

Detailed view Y:  
seating ring

- ①: Minimum water level (see diagram on the following page)
- ②: Approach flow
- ③: Vent line
- ④: Connect the discharge pipe to the discharge tube without transmitting any stresses or strains.
- ⑤: Not pressure-proof

Dimensions [mm]

Size	D	DN <sub>2 min</sub>	DN <sub>2 max</sub>	a	a <sub>1</sub>	a <sub>2</sub>	d <sub>7</sub>	e <sub>1</sub> <sup>22)</sup>	m	n	p <sub>1</sub>
700 - 330	711	300	600	650	860	610	570	430	930	1160	860
800 - 400	813	400	700	700	960	710	656	480	1030	1260	960
800 - 401	813	400	700	700	960	710	656	480	1030	1260	960
1000 - 420	1016	600	900	810	1160	910	856	600	1240	1500	1160
1000 - 421	1016	600	900	810	1160	910	856	600	1240	1500	1160
1000 - 500	1016	600	900	810	1160	910	856	600	1240	1500	1160
1200 - 630	1200	900	1200	910	1360	1110	1015	700	1440	1700	1360

21) All dimensions for foundation recesses apply to discharge tube design without intermediate flange.

22) Observe this dimension.

23) Value for maximum motor length

Dimensions [mm]

Size	p <sub>2</sub>	s <sub>1 min</sub>	s <sub>2 min</sub>	t <sub>2</sub> <sup>22)</sup>	t <sub>3</sub>	t <sub>4 min</sub> <sup>23)</sup>
700 - 330	960	8	1150	330	200	2450
800 - 400	1060	8	1400	410	250	2500
800 - 401	1060	8	1400	410	250	2500
1000 - 420	1260	10	1600	435	250	2700
1000 - 421	1260	10	1600	435	250	2700
1000 - 500	1260	10	1800	480	300	2950
1200 - 630	1460	12	2250	585	350	3500

Permissible deviations:

- Tolerances in building construction to DIN 18202, Part 4, Group B
- Welded design: B/F to DIN EN ISO 13920
- Tolerances for conical seat (detailed view Y): ISO 2768-mH
- Discharge flanges to DIN EN 1092-1 PN6 / DIN EN 1092-2 PN6

Loss diagram

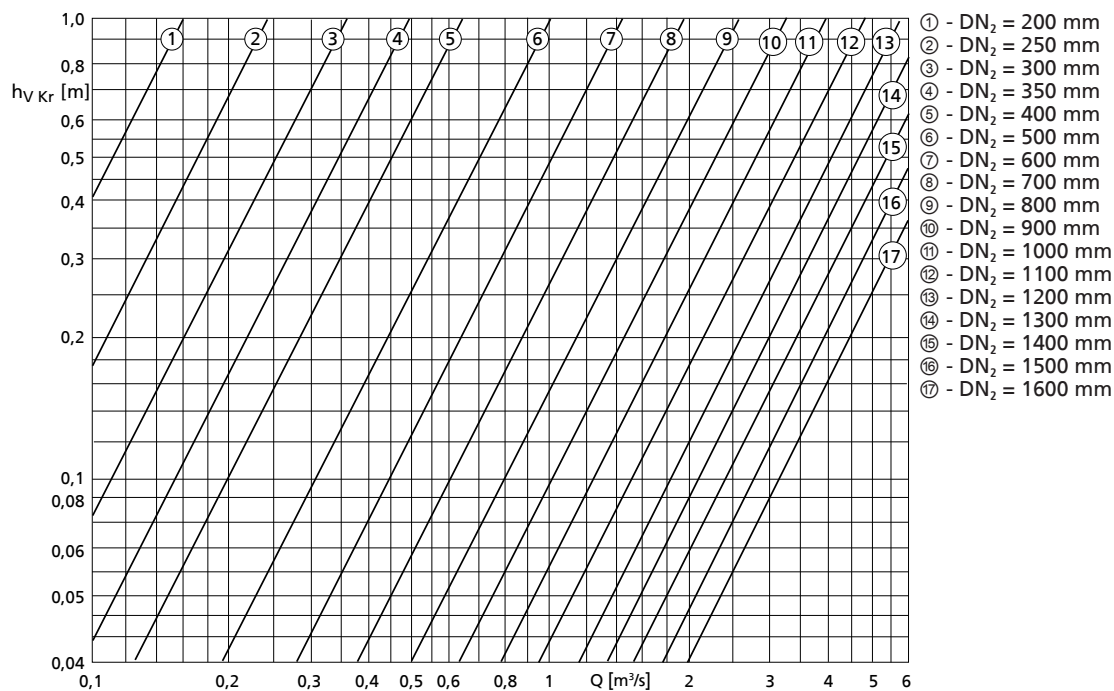

Calculation formulas:

$$H = H_{\text{geo}} + \Delta H_v$$

$\Delta H_v$

- Loss in the elbow  $h_{v,kr}$  (see diagram)
- Loss in the riser (pipe friction)
- $H_{v, \text{system}}$  (valves, etc.)

$H_{v, \text{system}}$  must be determined for the specific system.

Minimum water level diagram

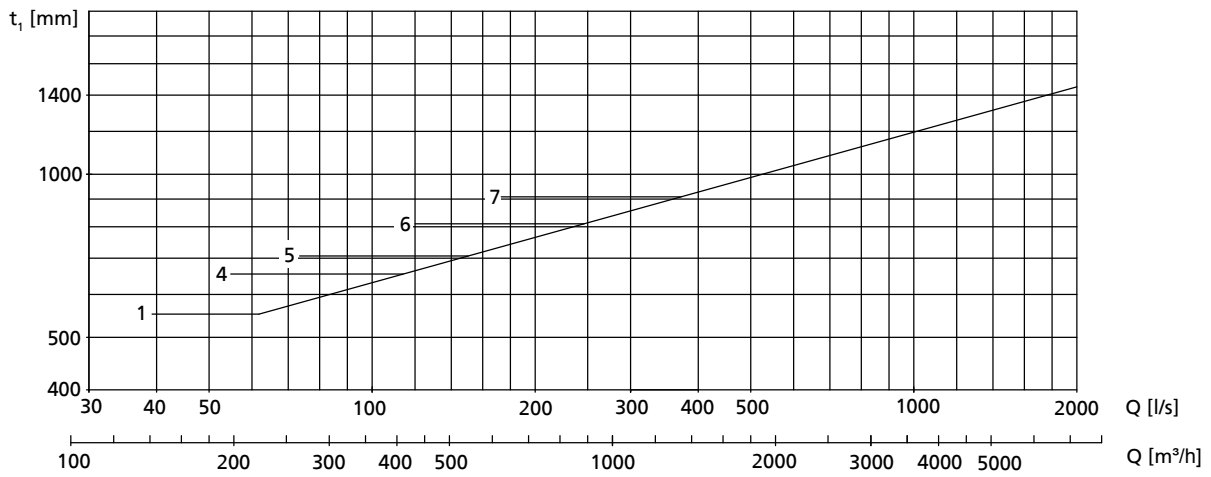

Fig. 7: Minimum water level diagram, motor version UN, XN, YN

1	Amacan K 700-330
4	Amacan K 800-400, 800-401
5	Amacan K 1000-420, 1000-421
6	Amacan K 1000-500
7	Amacan K 1200-630







**KSB SE & Co. KGaA**  
Johann-Klein-Straße 9 • 67227 Frankenthal (Germany)  
Tel. +49 6233 86-0  
[www.ksb.com](http://www.ksb.com)