

Submersible Pump in Discharge Tube

Amacan P

50 Hz

General Arrangement Drawings



Legal information/Copyright

General Arrangement Drawings Amacan P

All rights reserved. The contents provided herein must neither be distributed, copied, reproduced, edited or processed for any other purpose, nor otherwise transmitted, published or made available to a third party without the manufacturer's express written consent.

Subject to technical modification without prior notice.

© KSB SE & Co. KGaA, Frankenthal 09/02/2018

Contents

Water Applications: Water Transport 4

- Submersible Pump in Discharge Tube..... 4
- Amacan P..... 4
 - Designation 4
 - Selection information 4
 - Installation types..... 5
 - General arrangement drawings..... 6
 - BU type of installation (500-270 to 600-350)..... 6
 - BU type of installation (700-470 to 1600-1060)..... 8
 - BG type of installation (500-270 to 600-350)..... 11
 - BG type of installation (700-470 to 1600-1060)..... 13
 - CU type of installation (500-270 to 600-350)..... 15
 - CU type of installation (700-470 to 1600-1060)..... 18
 - CG type of installation (500-270 to 600-350)..... 21
 - CG type of installation (700-470 to 1600-1060)..... 23
 - DU type of installation (500-270 to 600-350) 25
 - DU type of installation (700-470 to 1600-1060) 28
 - DG type of installation (500-270 to 600-350) 31
 - DG type of installation (700-470 to 1600-1060) 33
 - Dimensions of the flow-straightening vane..... 35

Water Applications: Water Transport

Submersible Pump in Discharge Tube

Amacan P



Designation

Example: Amacan PA4 800-540 / 120 6UTG1

Key to the designation

Code	Description	
Amacan	Type series	
P	Impeller type, e.g. P = propeller	
A	Pressure class	
	A	
	B	
4	Number of vanes	
800	Nominal diameter of the discharge tube [mm]	
540	Nominal impeller diameter [mm]	
120	Motor size	
6	Number of motor poles	
	4	4-pole
	6	6-pole
	8	8-pole
	10	10-pole
	12	12-pole
UT	Motor version	
	UA	Without explosion protection, standard (sizes 500-270 ... 600-350)
	XA	Explosion protection to ATEX (sizes 500-270 ... 600-350)
	UT	Without explosion protection, standard (sizes 700-470 ... 1500-1600)
	XT	Explosion protection to ATEX (sizes 700-470 ... 1500-1600)
G1	Material variant	
	G1	Grey cast iron, standard material variant
	G3	Grey cast iron with Zn anodes, shaft made of 1.4057 stainless steel

Selection information

Information for pump selection

The guaranteed point of submersible pumps in discharge tubes is measured at a head 0.5 m above the motor (DIN 1184). The documented characteristic curves refer to this data. This must be taken into account when calculating system losses. The indicated heads and performance data apply to pumped fluids with a density $\rho = 1 \text{ kg/dm}^3$ and a kinematic viscosity ν of up to $20 \text{ mm}^2/\text{s}$.

The pump input power must be matched to the density of the fluid handled:

$$P_{2\text{req}} = \rho_{\text{fluid}} [\text{kg/dm}^3] \times P_{2\text{docu}}$$

The operating point with the largest pump input power is decisive for the operating range of the motor. To compensate the unavoidable tolerances of the characteristic curves of system, pump and motor we recommend selecting a motor size which provides sufficient power reserves.

Recommended minimum reserves¹⁾

Required pump input power [kW]	Motor power reserve	
	Mains operation	With frequency inverter
< 30	10 %	15 %
> 30	5 %	10 %

Intake chamber

Determine the minimum water level $t_{1\text{min}}$ (diagram in general arrangement drawing):

The minimum water level $t_{1\text{min}}$ is the water level required in the pump's suction chamber to ensure:

- that there is a sufficient liquid cover above the hydraulic system (propeller) (shown in diagram depending on pump size)
- that the pump does not draw in air-entraining vortices (shown in diagram depending on flow rate)
- that there is no cavitation in the hydraulic system (check against the $\text{NPSH}_{\text{required}}$ value indicated in the technical literature). The following conditions must be met:
 - $\text{NPSH}_{\text{available}} > \text{NPSH}_{\text{required}} + \text{safety allowance}$
 - $\text{NPSH}_{\text{available}} = 10.0 + (t_1 - t_3 - h_7/2)$
 - Safety allowance:
up to $Q_{\text{opt}} \Rightarrow 0.5 \text{ m}$
larger than $Q_{\text{opt}} \Rightarrow 1.0 \text{ m}$

Head (H)

The total pump head is composed as follows:

$$H = H_{\text{geo}} + \Delta H_v$$

H_{geo} (static head)

- Without discharge elbow – Difference between suction-side water level and overflow edge
- With discharge elbow – Difference between suction-side and discharge-side water level

ΔH_v (losses in the system)

- Starting 0.5 m downstream of the pump: e.g. pipe friction, elbow, swing check valve, etc.

1) If larger reserves are stipulated by local regulations or are required to compensate for uncertain factors in system calculations, these larger reserves must be provided.

Losses by inlet, riser and elbow

Losses are caused by the inlet, riser and elbow (or free discharge).

- Losses in the riser up to the indicated reference level (0.5 m above the motor) are taken into account in the documented characteristic curves.

- Inlet and elbow losses are system losses and must be taken into account for selection.
- For information on structural requirements, pump installation and pump sump design please refer to the KSB know-how brochure "Planning information: Amacan submersible pumps in discharge tubes" 0118.55.

Installation types

Overview of installation types

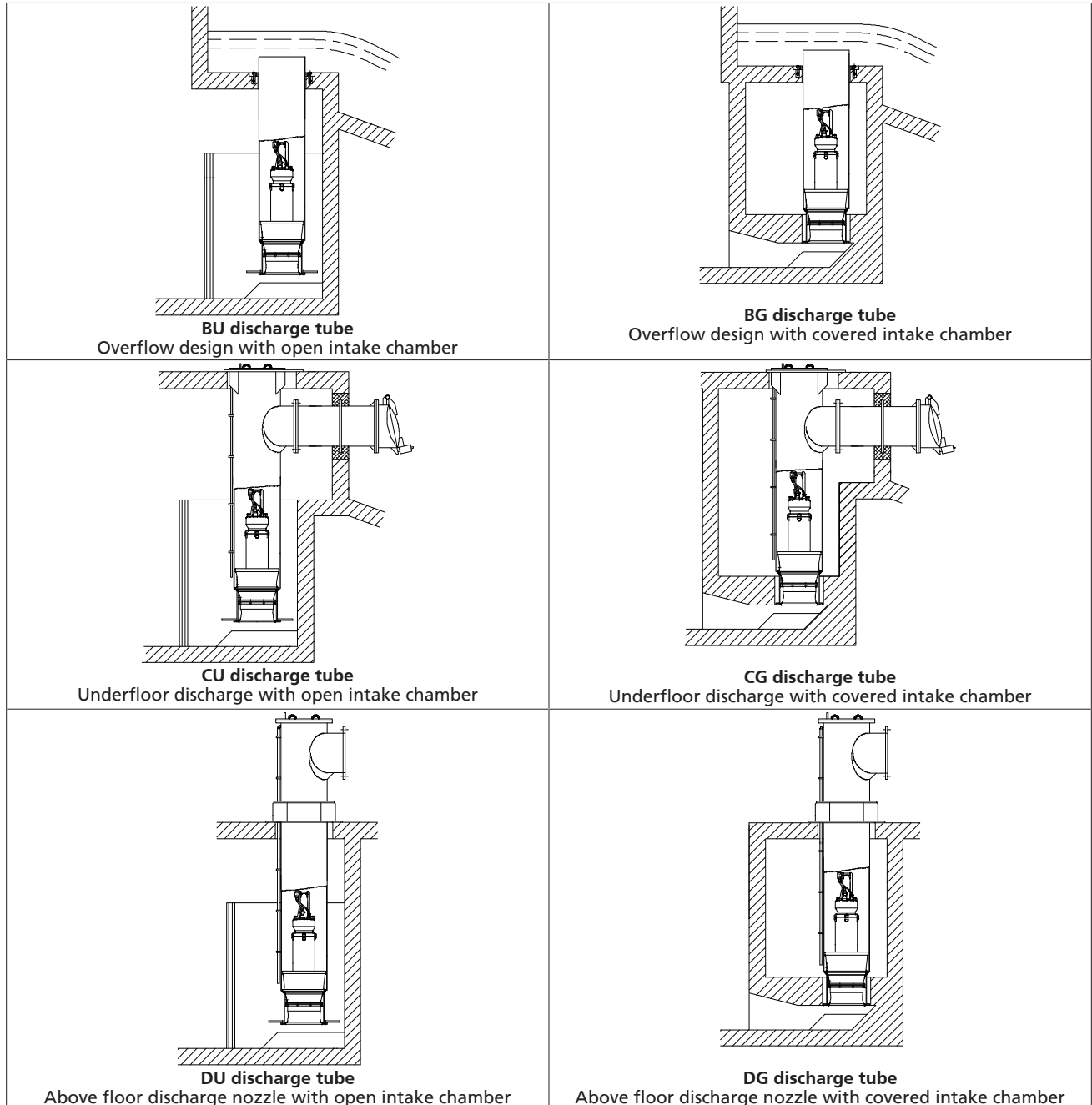

General arrangement drawings

BU type of installation (500-270 to 600-350)

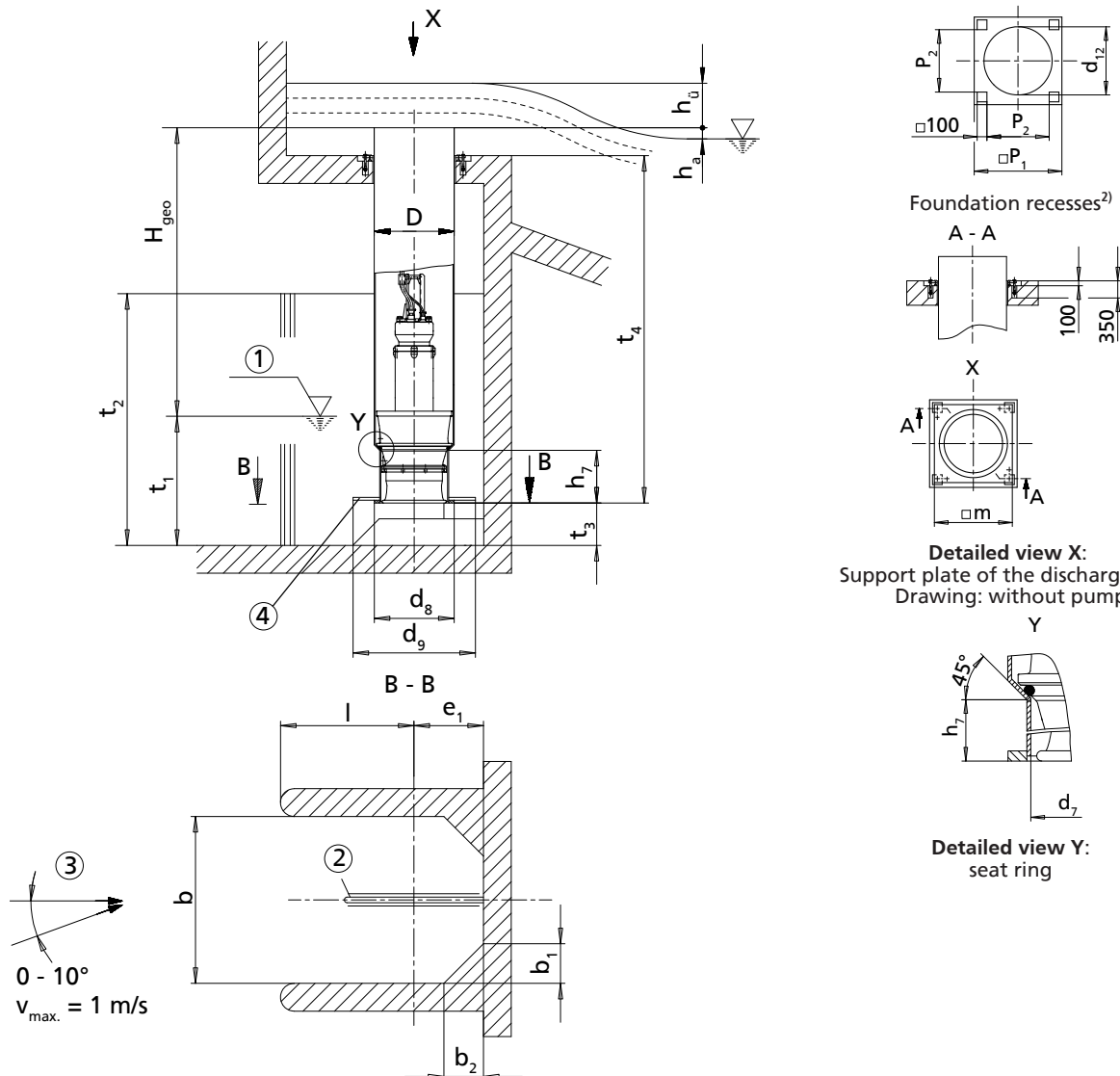

- ①: Minimum water level (values see diagram on the following page)
- ②: Flow-straightening vane (⇒ Page 35)
- ③: Approach flow
- ④: Suction umbrella - Option for reducing the minimum water level t_1

Dimensions [mm]

Size	D	b	b ₁		b ₂		d ₇	d ₈	d ₉
			without suction umbrella d ₈	with suction umbrella d ₉	without suction umbrella d ₈	with suction umbrella d ₉			
500 - 270	508	750	150	–	150	–	400	505	650
600 - 350	610	1250	250	–	250	–	500	610	800

- 2) All dimensions for foundation recesses apply to discharge tube design without intermediate flange.
- 3) Always observe this dimension.
- 4) Value for maximum motor length

Dimensions [mm]

Size	d ₁₂	e ₁ ³⁾		h _a	h ₇	l _{min.}	m	p ₁	p ₂	t ₃ ³⁾	t _{4 min.} ⁴⁾
		without suction umbrella d ₈	with suction umbrella d ₉								
500 - 270	550	350	400	100	295	400	600	700	440	200	1600
600 - 350	650	400	500	100	540	850	700	800	540	320	1900

t₂ = 1.1 x water level, maximum 2 x t₁
Height of corner lining (b₁ and b₂) like t₂

Permissible tolerances:

- Tolerances in building construction to DIN 18202, Part 4, Group B
- Welded design: B/F to DIN EN ISO 13920
- Tolerances for conical seat (detailed view Y): ISO 2768-mH

Loss diagram

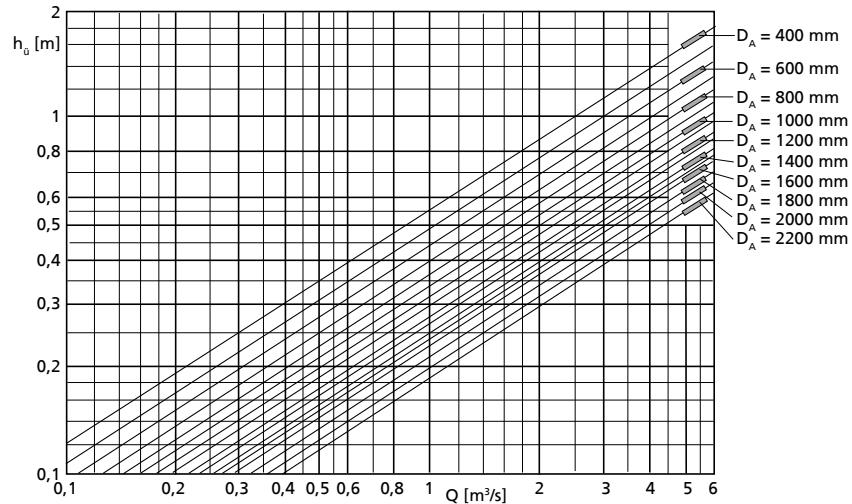
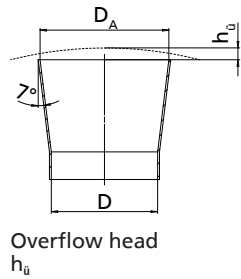

Loss diagram

Calculation formulas:

$H = H_{geo} + \Delta H_v$

ΔH_v

- Overflow head h_ü (see diagram)
- Loss in the riser (pipe friction)
- Outlet loss $v^2/2g$ (v refers to D_A)

Overflow head h_ü depends on Q and the discharge diameter D_A. The characteristic curve values only apply to unimpeded outlet in all directions; otherwise they are approximate values only.

Minimum water level diagrams

Open intake chamber
(design without suction umbrella Ø d₈)

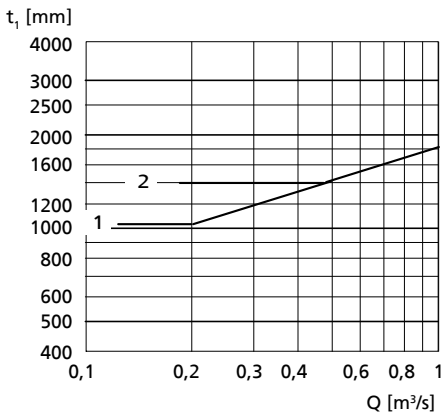

Open intake chamber
(design with suction umbrella Ø d₉)

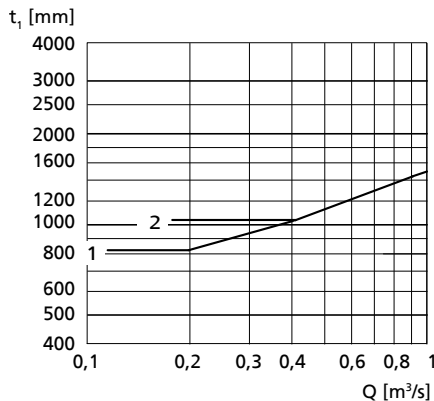

Key

- 1 - Amacan P 500-270
- 2 - Amacan P 600-350

BU type of installation (700-470 to 1600-1060)

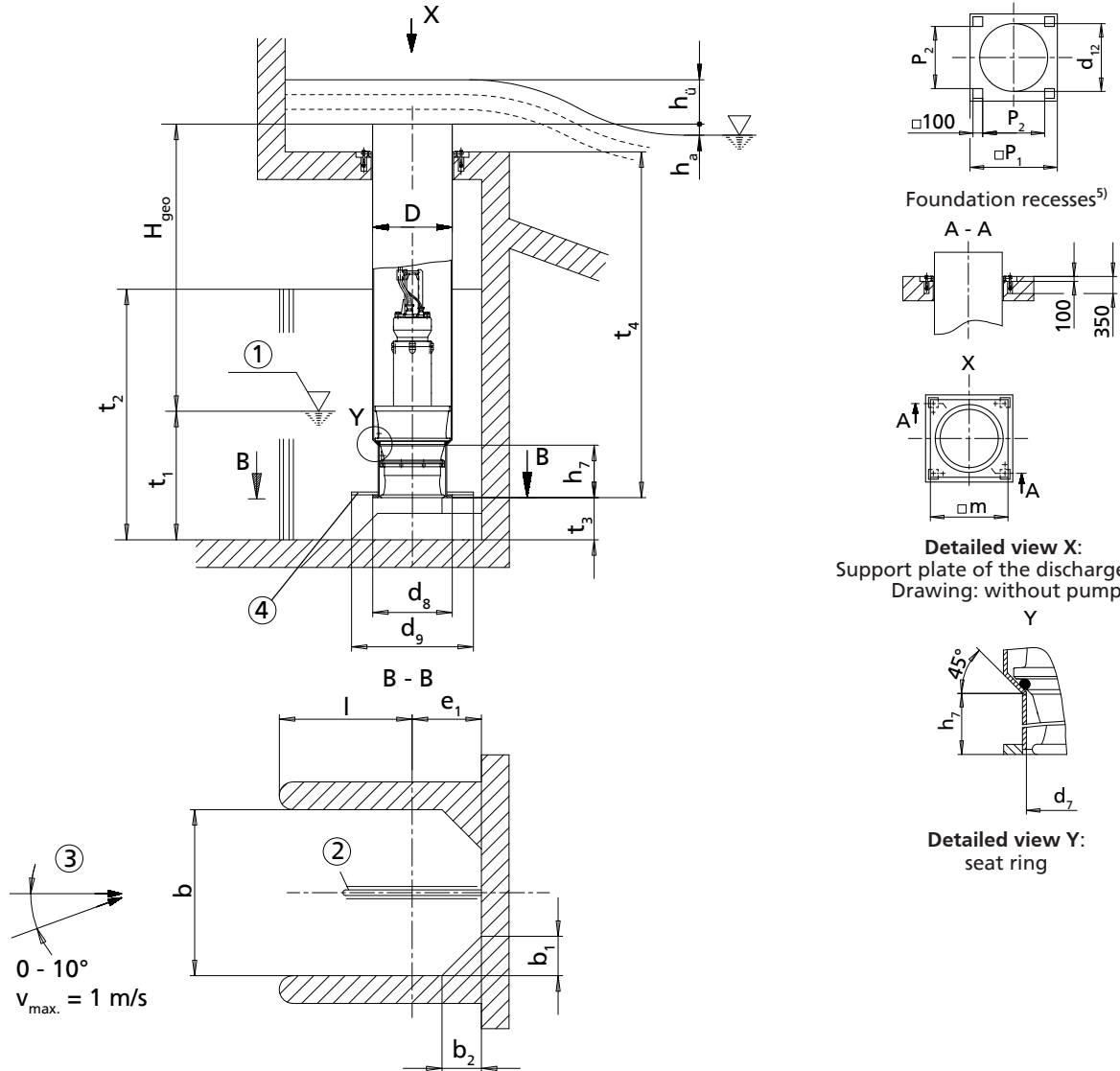

- ①: Minimum water level (values see diagram on the following pages)
- ②: Flow-straightening vane (⇒ Page 35)
- ③: Approach flow
- ④: Suction umbrella - Option for reducing the minimum water level t_1

Dimensions [mm]

Size	D	b	b_1		b_2		d_7	d_8	d_9	d_{12}
			Without suction umbrella d_8	With suction umbrella d_9	Without suction umbrella d_8	With suction umbrella d_9				
700 - 470	711	1500	300	–	300	–	600	710	1100	750
800 - 540	813	1800	360	–	360	–	680	810	1250	850
900 - 540	914	1800	360	–	360	–	700	910	1250	970
1000 - 700	1016	2300	460	–	460	–	880	1015	1600	1070
1200 - 870	1220	2800	560	–	560	–	1070	1220	2000	1280
1500 - 1060	1524	3500	700	–	700	–	1330	1520	2450	1590
1600 - 1060	1625	3500	700	–	700	–	1420	1620	2450	1690

5) All dimensions for foundation recesses apply to discharge tube design without intermediate flange.
6) Always observe this dimension.
7) Value for maximum motor length

Dimensions [mm]

Size	e ₁ ⁶⁾		h ₇	h _a	l _{min.}	m	p ₁	p ₂	t ₃ ⁶⁾	t _{4 min.} ⁷⁾
	Without suction umbrella d ₈	With suction umbrella d ₉								
700 - 470	450	650	420	100	1050	800	900	640	380	2300
800 - 540	500	700	525	100	1300	910	1000	740	440	2350
900 - 540	550	700	515	100	1300	1050	1120	860	440	2500
1000 - 700	600	900	765	100	1700	1150	1220	960	560	3050
1200 - 870	700	1100	1000	100	2100	1360	1420	1160	680	3750
1500 - 1060	850	1300	1460	100	2650	1680	1750	1480	860	3900
1600 - 1060	900	1300	1230	100	2600	1780	1850	1580	860	4350

t₂ = 1.1 x water level, maximum 2 x t₁
Height of corner lining (b₁ and b₂) like t₂

Permissible tolerances:

- Tolerances in building construction to DIN 18202, Part 4, Group B
- Welded design: B/F to DIN EN ISO 13920
- Tolerances for conical seat (detailed view Y): ISO 2768-mH

Loss diagram

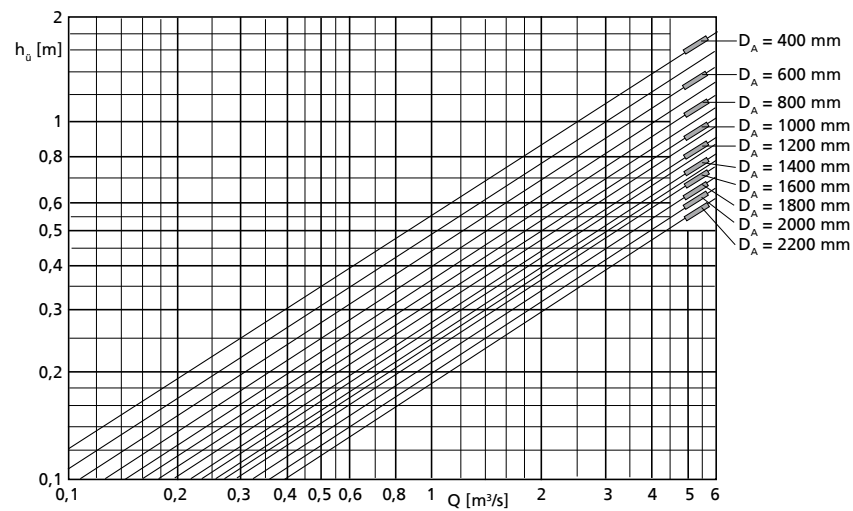
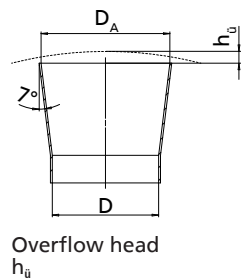

Calculation formulas:

$$H = H_{geo} + \Delta H_v$$

$$\Delta H_v$$

- Overflow head h_i (see diagram)
- Loss in the riser (pipe friction)
- Outlet loss v²/2 g (v refers to D_A)

Overflow head h_i depends on Q and the discharge diameter D_A. The characteristic curve values only apply to unimpeded outlet in all directions; otherwise they are approximate values only.

Minimum water level diagrams

Open intake chamber
(design without suction umbrella $\varnothing d_8$)

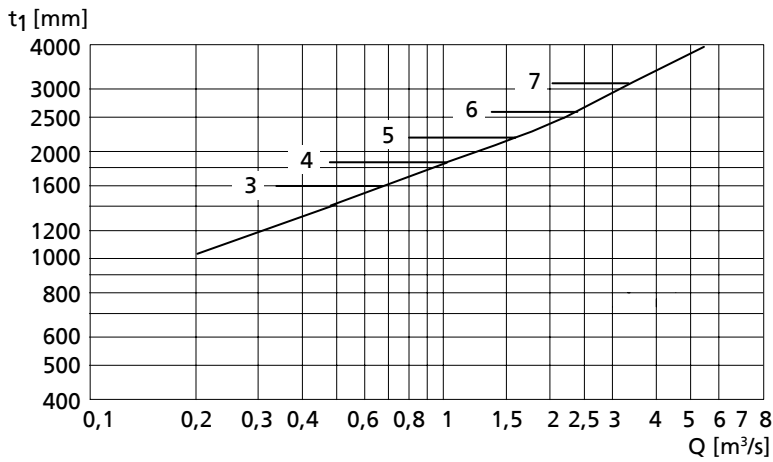

Key

- 3 - Amacan P 700 - 470
- 4 - Amacan P 800/900 - 540
- 5 - Amacan P 1000 - 700
- 6 - Amacan P 1200 - 870
- 7 - Amacan P 1500/1600-1060

Open intake chamber
(design with suction umbrella $\varnothing d_9$)

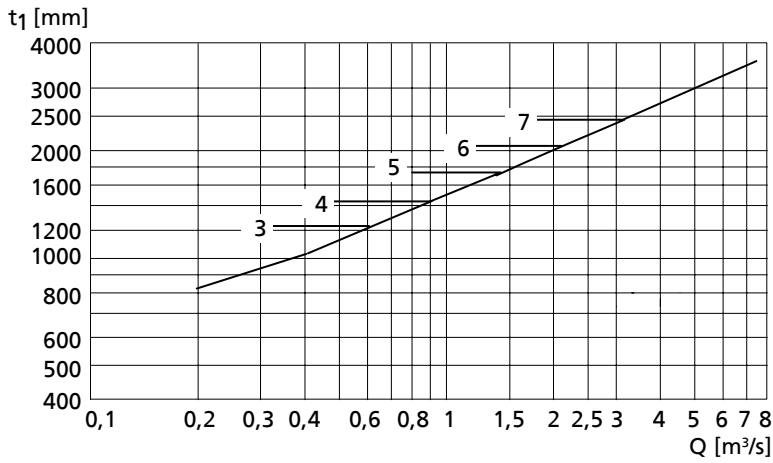

BG type of installation (500-270 to 600-350)

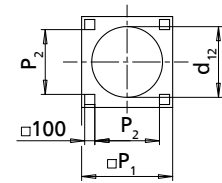
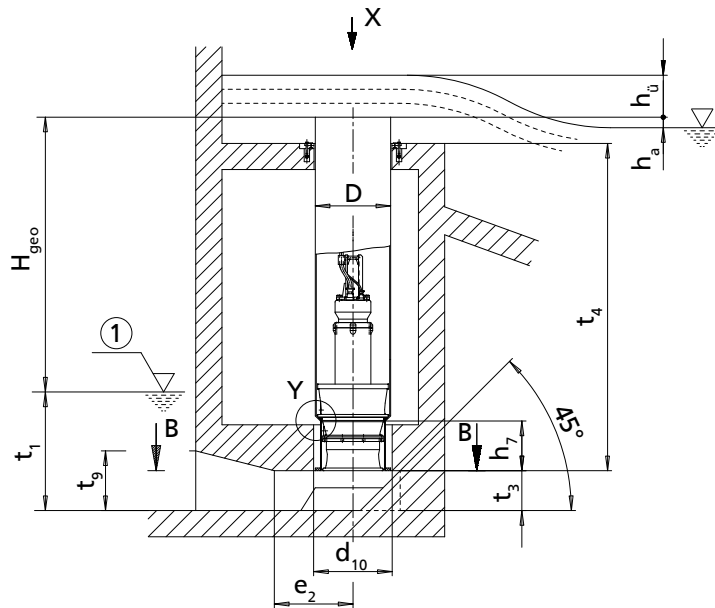

Foundation recesses⁸⁾

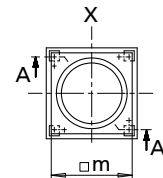
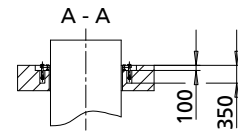

Detailed view X:
Support plate of the discharge tube
Drawing: without pump

Y

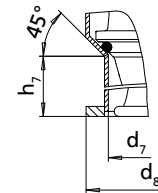

Detailed view Y:
seat ring

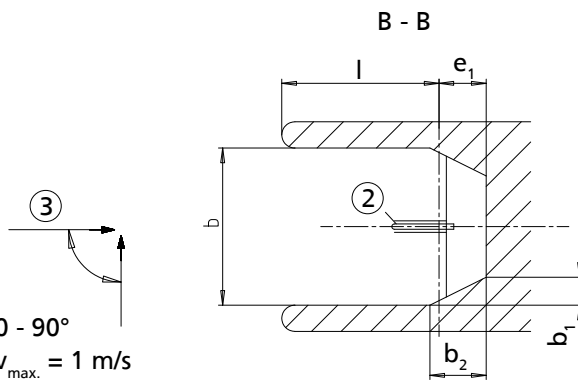

- ① Minimum water level (values see diagram on the next page)
- ② Flow-straightening vane (⇒ Page 35)
- ③ Approach flow

Dimensions [mm]

Size	D	b	b ₁	b ₂	d ₇	d ₈	d ₁₀	d ₁₂	e ₁ ⁹⁾	e ₂
500 - 270	508	750	150	300	400	505	540	550	259	375
600 - 350	610	1250	250	500	500	610	640	650	375	625

Dimensions [mm]

Size	h _a	h ₇	l _{min.}	m	p ₁	p ₂	t ₃ ⁹⁾	t _{4 min.} ¹⁰⁾	t ₉
500 - 270	100	295	750	600	700	440	200	1600	280
600 - 350	100	540	1250	700	800	540	320	1900	470

8) All dimensions for foundation recesses apply to discharge tube design without intermediate flange.
9) Always observe this dimension.
10) Value for maximum motor length

Permissible tolerances:

- Tolerances in building construction to DIN 18202, Part 4, Group B
- Welded design: B/F to DIN EN ISO 13920
- Tolerances for conical seat (detailed view Y): ISO 2768-mH

Loss diagram

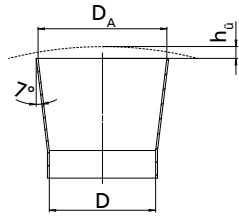

Overflow head h_i

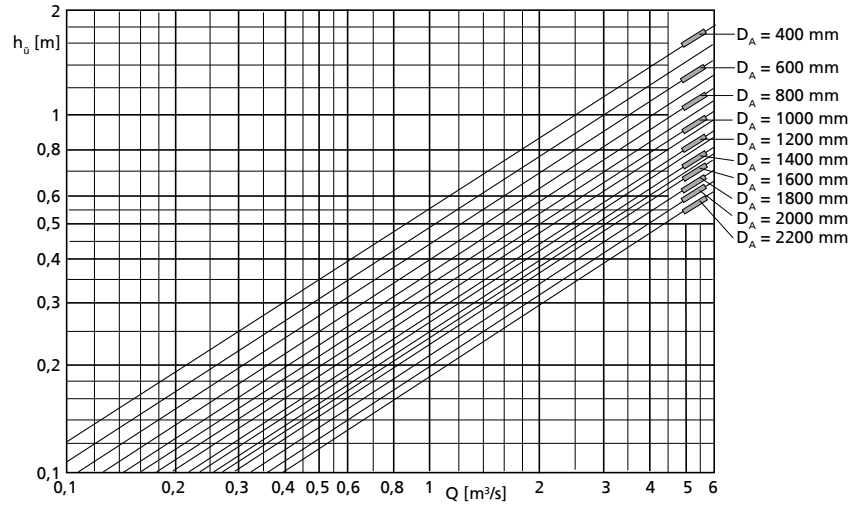

Loss diagram

Calculation formulas:

$$H = H_{geo} + \Delta H_v$$

ΔH_v

- Overflow head h_i (see diagram)
- Loss in the riser (pipe friction)
- Outlet loss $v^2/2g$ (v refers to D_A)

Overflow head h_i depends on Q and the discharge diameter D_A . The characteristic curve values only apply to unimpeded outlet in all directions; otherwise they are approximate values only.

Minimum water level diagram

Covered intake chamber

t_i [mm]

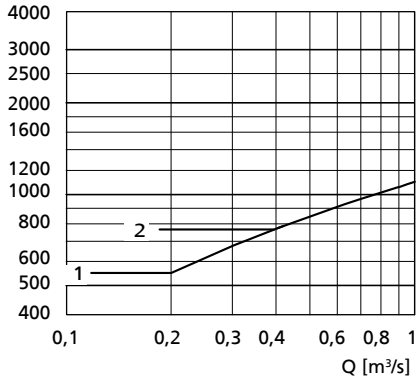

Key

- 1 - Amacan P 500-270
- 2 - Amacan P 600-350

BG type of installation (700-470 to 1600-1060)

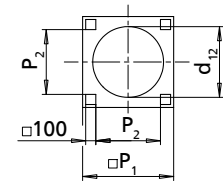
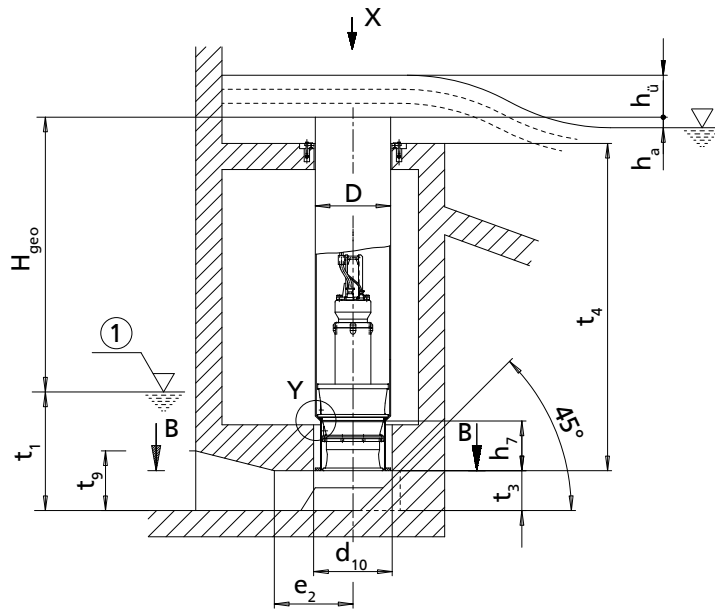

Foundation recesses¹¹⁾

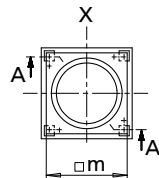
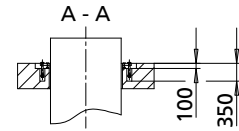

Detailed view X:
Support plate of the discharge tube
Drawing: without pump

Y

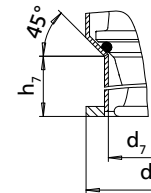

Detailed view Y:
seat ring

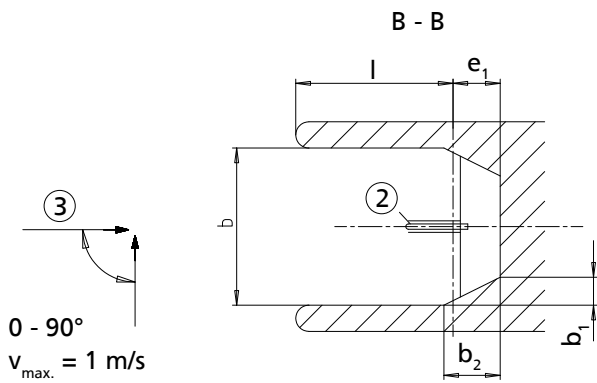

- ①: Minimum water level (values see diagrams on the following pages)
- ②: Flow-straightening vane (⇒ Page 35)
- ③: Approach flow

Dimensions [mm]

Size	D	b	b ₁	b ₂	d ₇	d ₈	d ₁₀	d ₁₂	e ₁ ¹²⁾	e ₂
700 - 470	711	1500	300	600	600	710	740	750	450	750
800 - 540	813	1800	360	720	680	810	860	850	519	900
900 - 540	914	1800	360	720	700	910	960	970	519	900
1000 - 700	1016	2300	460	920	880	1015	1080	1070	673	1150
1200 - 870	1220	2800	560	1120	1070	1220	1290	1280	833	1400
1500 - 1060	1524	3500	700	1400	1330	1520	1600	1590	1048	1750
1600 - 1060	1625	3500	700	1400	1420	1620	1700	1690	1048	1750

Dimensions [mm]

Size	h _a	h ₇	l _{min.}	m	p ₁	p ₂	t ₃ ¹²⁾	t _{4 min.} ¹³⁾	t ₉
700 - 470	100	420	1500	800	910	640	380	2300	570
800 - 540	100	525	1800	910	1000	740	440	2350	660
900 - 540	100	515	1800	1050	1120	860	440	2500	660
1000 - 700	100	765	2300	1150	1220	960	560	3050	850

- 11) All dimensions for foundation recesses apply to discharge tube design without intermediate flange.
- 12) Always observe this dimension.
- 13) Value for maximum motor length

Size	h_a	h_7	$l_{min.}$	m	p_1	p_2	$t_3^{(12)}$	$t_{4 min.}^{(13)}$	t_9
1200 - 870	100	1000	2800	1360	1420	1160	680	3750	1050
1500 - 1060	100	1460	3500	1680	1750	1480	860	3900	1320
1600 - 1060	100	1230	3500	1780	1850	1580	860	4350	1320

Permissible tolerances:

- Tolerances in building construction to DIN 18202, Part 4, Group B
- Welded design: B/F to DIN EN ISO 13920
- Tolerances for conical seat (detailed view Y): ISO 2768-mH

Loss diagram

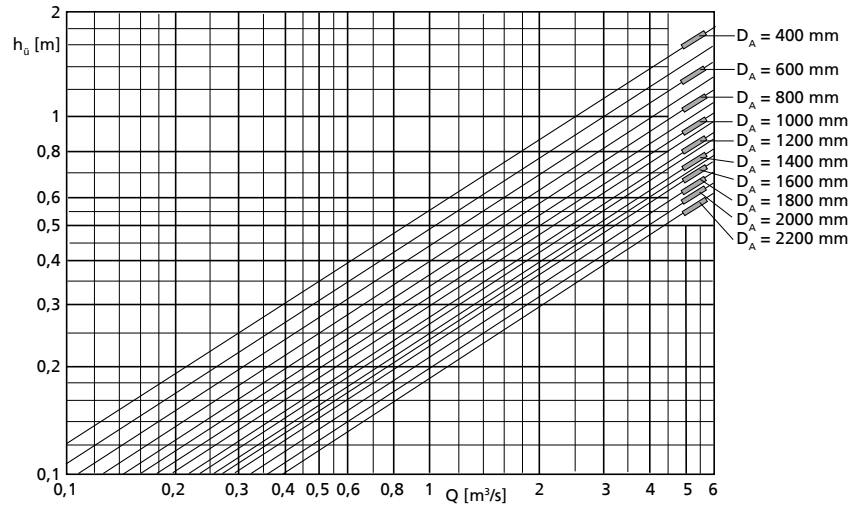
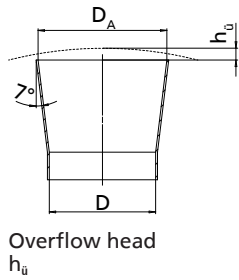

Calculation formulas:

$$H = H_{geo} + \Delta H_v$$

$$\Delta H_v$$

- Overflow head h_u (see diagram)
- Loss in the riser (pipe friction)
- Outlet loss $v^2/2 g$ (v refers to D_A)

Overflow head h_u depends on Q and the discharge diameter D_A . The characteristic curve values only apply to unimpeded outlet in all directions; otherwise they are approximate values only.

Minimum water level diagram

Covered intake chamber

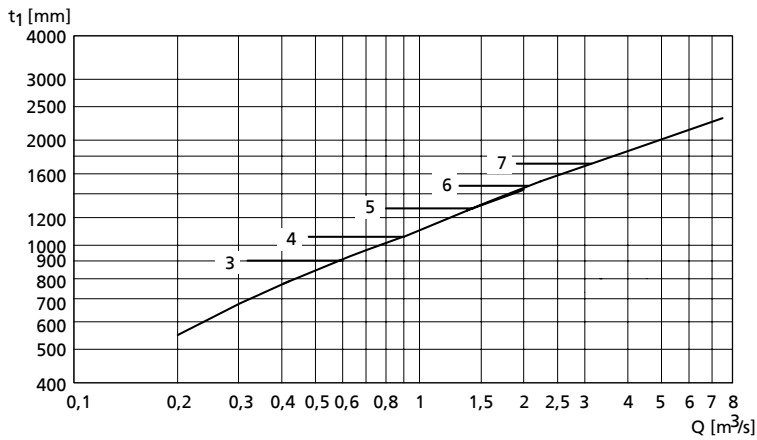

Key

- 3 - Amacan P 700 - 470
- 4 - Amacan P 800/900 - 540
- 5 - Amacan P 1000 - 700
- 6 - Amacan P 1200 - 870
- 7 - Amacan P 1500/1600 - 1060

CU type of installation (500-270 to 600-350)

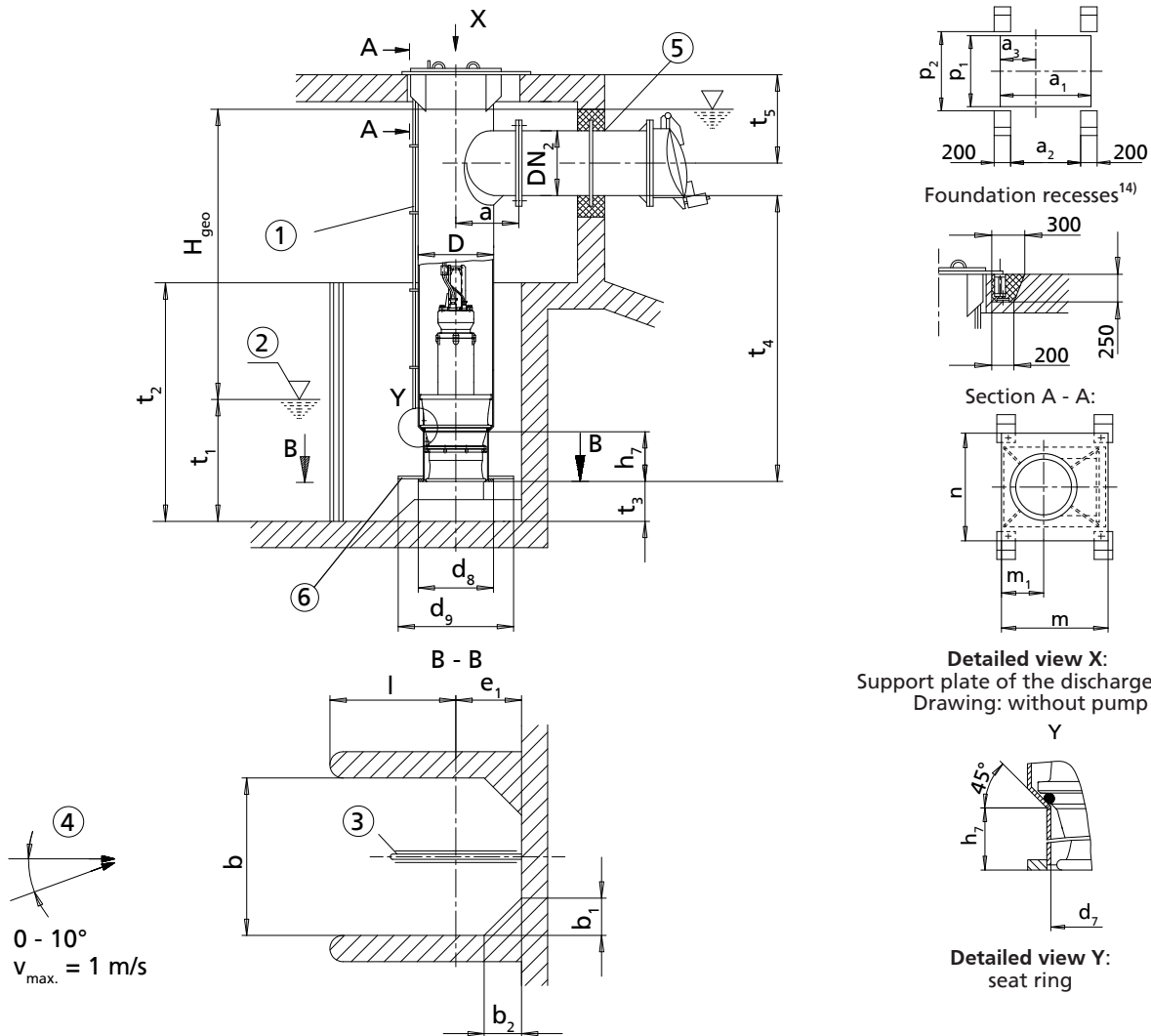

- ①: Vent line
- ②: Minimum water level (values see diagram on the following page)
- ③: Flow-straightening vane (⇒ Page 35)
- ④: Approach flow
- ⑤: Connect the discharge pipe to the discharge tube without transmitting any stresses or strains.
- ⑥: Suction umbrella - Option for reducing the minimum water level t_1

Dimensions [mm]

Size	DN _{2 min.}	DN _{2 max.}	D	a	a ₁ ¹⁵⁾	a ₂ ¹⁵⁾	a ₃ ¹⁵⁾	b	b ₁		b ₂	
									without suction umbrella d ₈	with suction umbrella d ₉	without suction umbrella d ₈	with suction umbrella d ₉
500 - 270	300	500	508	530	880	630	325	750	150	–	150	–
600 - 350	350	600	610	580	1000	750	380	1250	250	–	250	–

14) All dimensions for foundation recesses apply to discharge tube design without intermediate flange.
 15) Designed for DN 2 max.
 16) Always observe this dimension.
 17) Value for maximum motor length

Dimensions [mm]

Size	d ₇	d ₈	d ₉	e ₁ ¹⁶⁾		h ₇	l _{min.}	m ¹⁵⁾	m ₁ ¹⁵⁾	n ¹⁵⁾	p ₁ ¹⁵⁾	p ₂ ¹⁵⁾	t ₃ ¹⁶⁾	t _{4 min.} ¹⁷⁾	t _{5 min.} ¹⁵⁾
				without suction umbrella d ₈	with suction umbrella d ₉										
500 - 270	400	505	650	350	400	295	400	930	350	1060	760	860	200	1700	670
600 - 350	500	610	800	400	500	540	850	1050	405	1160	860	960	320	2000	720

t₂ = 1.1 x water level, maximum 2 x t₁
Height of corner lining (b₁ and b₂) like t₂

Permissible tolerances:

- Tolerances in building construction to DIN 18202, Part 4, Group B
- Welded design: B/F to DIN EN ISO 13920
- Tolerances for conical seat (detailed view Y): ISO 2768-mH
- Discharge flanges to DIN EN 1092-1 PN6 / DIN EN 1092-2 PN6

Loss diagram

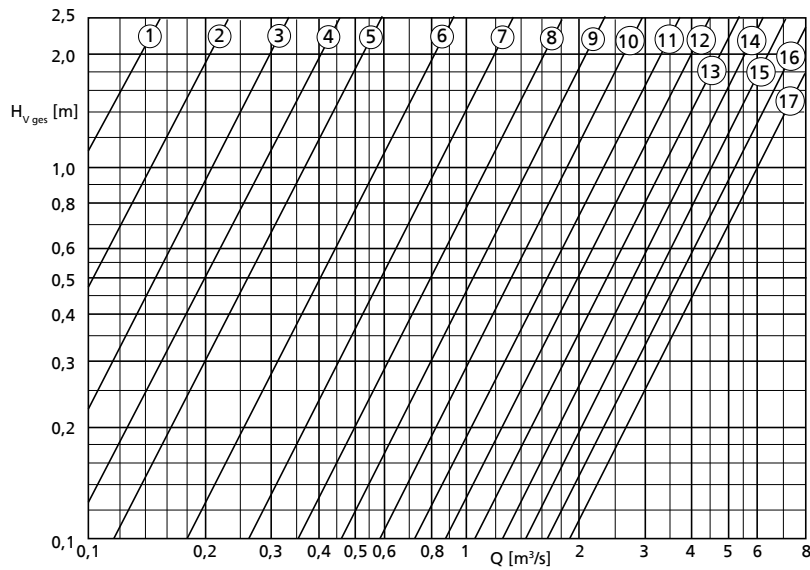

- ① - DN₂ = 200 mm
- ② - DN₂ = 250 mm
- ③ - DN₂ = 300 mm
- ④ - DN₂ = 350 mm
- ⑤ - DN₂ = 400 mm
- ⑥ - DN₂ = 500 mm
- ⑦ - DN₂ = 600 mm
- ⑧ - DN₂ = 700 mm
- ⑨ - DN₂ = 800 mm
- ⑩ - DN₂ = 900 mm
- ⑪ - DN₂ = 1000 mm
- ⑫ - DN₂ = 1100 mm
- ⑬ - DN₂ = 1200 mm
- ⑭ - DN₂ = 1300 mm
- ⑮ - DN₂ = 1400 mm
- ⑯ - DN₂ = 1500 mm
- ⑰ - DN₂ = 1600 mm

Calculation formulas:

$$H = H_{geo} + \Delta H_v$$

ΔH_v

- Loss in the riser (pipe friction)
- H_{v ges.} (see diagram)

H_{v ges.} comprises:

- Elbow
- Discharge pipe length = 5 x DN₂
- Swing check valve
- Outlet losses v²/2g

Minimum water level diagrams

Open intake chamber
(design without suction umbrella $\varnothing d_8$)

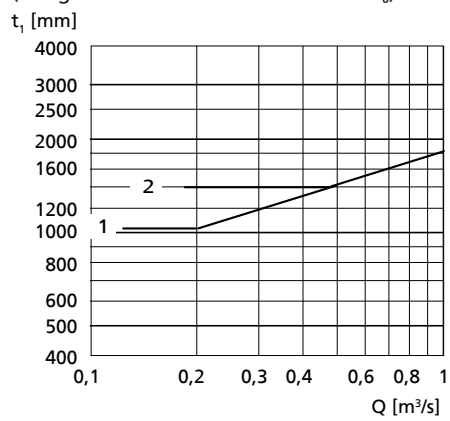

Open intake chamber
(design with suction umbrella $\varnothing d_9$)

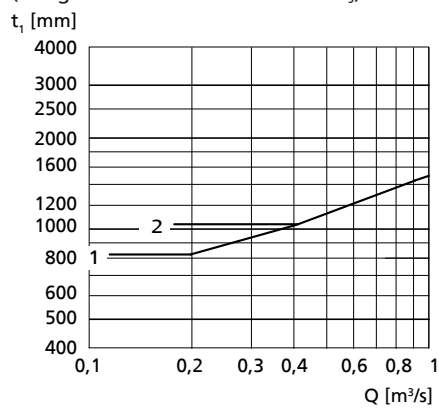

Key

- 1 - Amacan P 500-270
- 2 - Amacan P 600-350

CU type of installation (700-470 to 1600-1060)

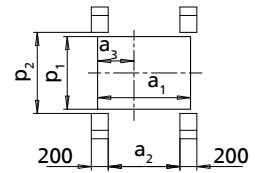
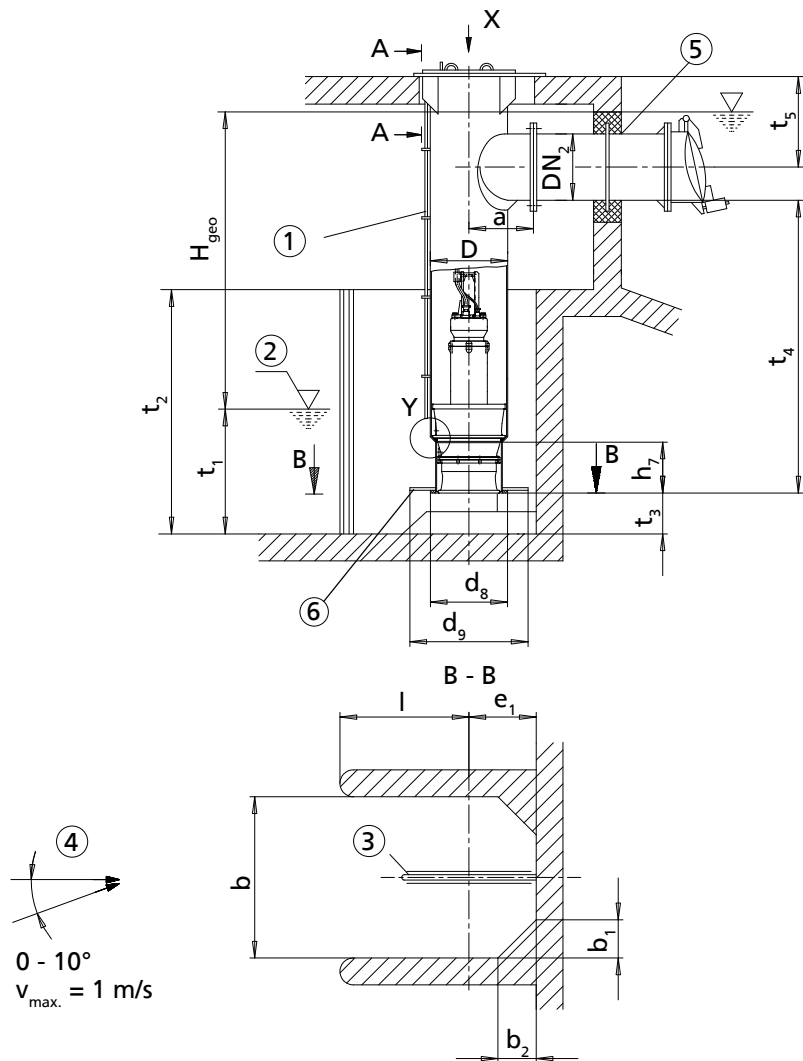

Foundation recesses¹⁸⁾

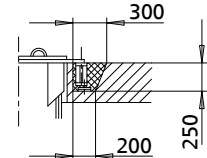

Section A - A:

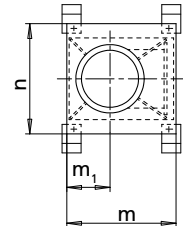

Detailed view X:
Support plate of the discharge tube
Drawing: without pump

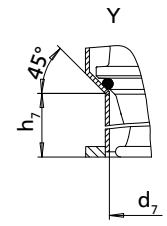

Detailed view Y:
seat ring

- ①: Vent line
- ②: Minimum water level (values see diagram on the following pages)
- ③: Flow-straightening vane (⇒ Page 35)
- ④: Approach flow
- ⑤: Connect the discharge pipe to the discharge tube without transmitting any stresses or strains.
- ⑥: Suction umbrella - Option for reducing the minimum water level t_1

Dimensions [mm]

Size	DN ₂ min.	DN ₂ max.	D	a	a ₁ ¹⁹⁾	a ₂ ¹⁹⁾	a ₃ ¹⁹⁾	b	b ₁		b ₂	
									Without suction umbrella d ₈	With suction umbrella d ₉	Without suction umbrella d ₈	With suction umbrella d ₉
700 - 470	400	700	711	650	1120	870	430	1500	300	–	300	–
800 - 540	500	800	813	700	1220	970	480	1800	360	–	360	–
900 - 540	600	900	914	760	1320	1070	530	1800	360	–	360	–
1000 - 700	700	1000	1016	810	1430	1160	580	2300	460	–	460	–
1200 - 870	900	1200	1220	910	1630	1360	680	2800	560	–	560	–
1500 - 1060	1200	1500	1524	1060	1960	1690	850	3500	700	–	700	–
1600 - 1060	1300	1600	1625	1110	2080	1810	920	3500	700	–	700	–

18) All dimensions for foundation recesses apply to discharge tube design without intermediate flange.
 19) Designed for DN 2 max.
 20) Always observe this dimension.
 21) Value for maximum motor length

Dimensions [mm]

Size	d ₇	d ₈	d ₉	e ₁ ²⁰⁾		h ₇	l _{min.}	m ¹⁹⁾	m ₁ ¹⁹⁾	n ¹⁹⁾	p ₁ ¹⁹⁾	p ₂ ¹⁹⁾	t ₃ ²⁰⁾	t _{4 min.} ²¹⁾	t _{5 min.} ¹⁹⁾
				Without suction umbrella d ₈	With suction umbrella d ₉										
700 - 470	600	710	1100	450	650	420	1050	1170	455	1260	960	1060	380	2400	770
800 - 540	680	810	1250	500	700	525	1300	1270	505	1375	1075	1175	440	2450	835
900 - 540	700	910	1250	550	700	515	1300	1380	560	1480	1180	1280	440	2650	925
1000 - 700	880	1015	1600	600	900	765	1700	1520	625	1620	1280	1380	560	3250	980
1200 - 870	1070	1220	2000	700	1100	1000	2100	1720	725	1850	1510	1610	680	4000	1100
1500 - 1060	1330	1520	2450	850	1300	1460	2650	2050	895	2180	1840	1940	860	4050	1300
1600 - 1060	1420	1620	2450	900	1300	1230	2600	2170	965	2280	1940	2040	860	4450	1380

t₂ = 1.1 x water level, maximum 2 x t₁
Height of corner lining (b₁ and b₂) like t₂

Permissible tolerances:

- Tolerances in building construction to DIN 18202, Part 4, Group B
- Welded design: B/F to DIN EN ISO 13920
- Tolerances for conical seat (detailed view Y): ISO 2768-mH
- Discharge flanges to DIN EN 1092-1 PN6 / DIN EN 1092-2 PN6

Loss diagram

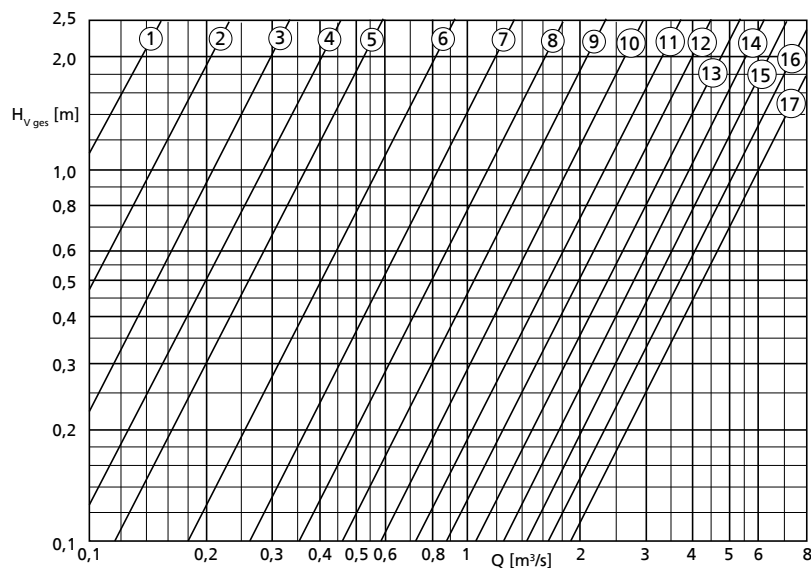

- ① - DN₂ = 200 mm
- ② - DN₂ = 250 mm
- ③ - DN₂ = 300 mm
- ④ - DN₂ = 350 mm
- ⑤ - DN₂ = 400 mm
- ⑥ - DN₂ = 500 mm
- ⑦ - DN₂ = 600 mm
- ⑧ - DN₂ = 700 mm
- ⑨ - DN₂ = 800 mm
- ⑩ - DN₂ = 900 mm
- ⑪ - DN₂ = 1000 mm
- ⑫ - DN₂ = 1100 mm
- ⑬ - DN₂ = 1200 mm
- ⑭ - DN₂ = 1300 mm
- ⑮ - DN₂ = 1400 mm
- ⑯ - DN₂ = 1500 mm
- ⑰ - DN₂ = 1600 mm

Calculation formulas:

H = H_{geo} + Δ H_v

Δ H_v

- Loss in the riser (pipe friction)
- H_{v ges.} (see diagram)

H_{v ges.} comprises:

- Elbow
- Discharge pipe length = 5 x DN₂
- Swing check valve
- Outlet losses v²/2g

Minimum water level diagrams

Open intake chamber
(design without suction umbrella $\varnothing d_8$)

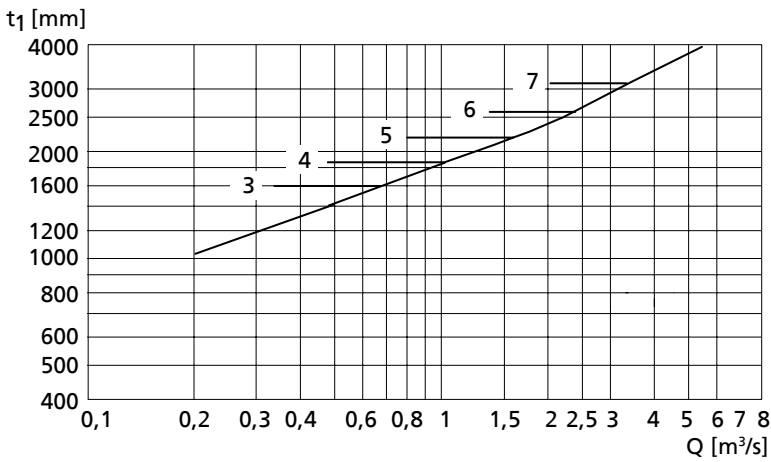

Key

- 3 - Amacan P 700 - 470
- 4 - Amacan P 800/900 - 540
- 5 - Amacan P 1000 - 700
- 6 - Amacan P 1200 - 870
- 7 - Amacan P 1500/1600-1060

Open intake chamber
(design with suction umbrella $\varnothing d_9$)

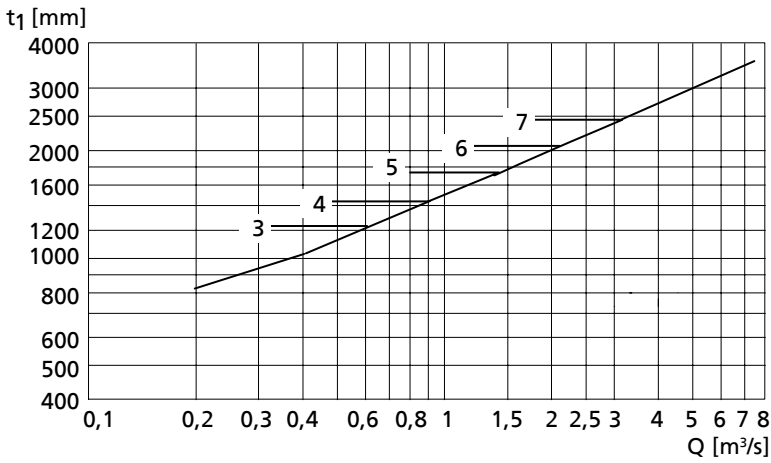

CG type of installation (500-270 to 600-350)

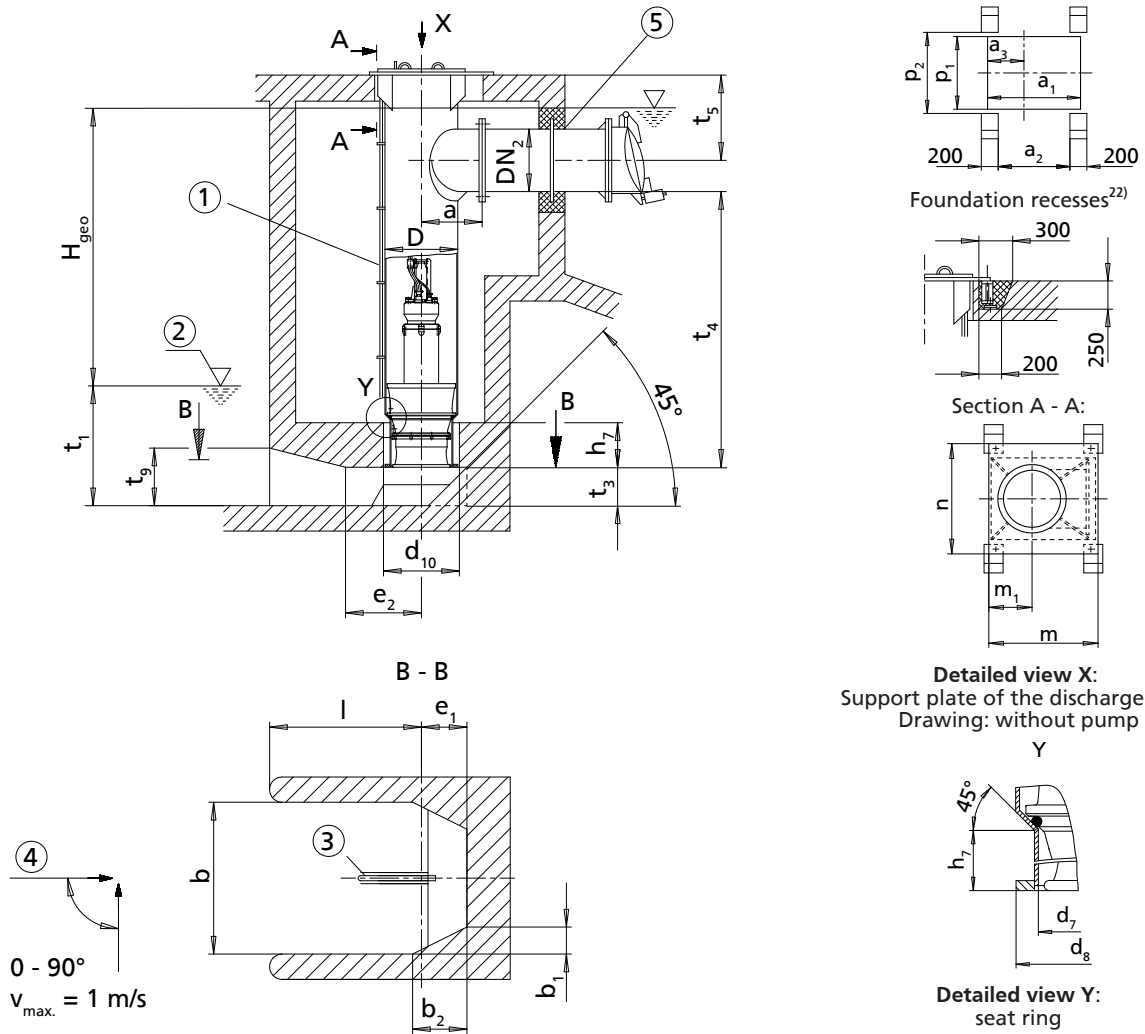

- ①: Vent line
- ②: Minimum water level (values see diagram on the next page)
- ③: Flow-straightening vane (⇒ Page 35)
- ④: Approach flow
- ⑤: Connect the discharge pipe to the pump without transmitting any stresses or strains.

Dimensions [mm]

Size	DN _{2 min.}	DN _{2 max.}	D	a	a ₁ ²³⁾	a ₂ ²³⁾	a ₃ ²³⁾	b	b ₁	b ₂	d ₇	d ₈	d ₁₀
500 - 270	300	500	508	530	880	630	325	750	150	300	400	505	540
600 - 350	350	600	610	580	1000	750	380	1250	250	500	500	610	640

Dimensions [mm]

Size	e ₁ ²⁴⁾	e ₂	h ₇	l _{min.}	m ²³⁾	m ₁ ²³⁾	n ²³⁾	p ₁ ²³⁾	p ₂ ²³⁾	t ₃ ²⁴⁾	t _{4 min.} ²⁵⁾	t _{5 min.} ²³⁾	t ₉
500 - 270	259	375	295	750	930	350	1060	760	860	200	1700	670	280
600 - 350	375	625	540	1250	1050	405	1160	860	960	320	2000	720	470

Permissible tolerances:

- Tolerances in building construction to DIN 18202, Part 4, Group B
- Welded design: B/F to DIN EN ISO 13920
- Tolerances for conical seat (detailed view Y): ISO 2768-mH
- Discharge flanges to DIN EN 1092-1 PN6 / DIN EN 1092-2 PN6

22) All dimensions for foundation recesses apply to discharge tube design without intermediate flange.

23) Designed for DN 2 max.

24) Always observe this dimension.

25) Value for maximum motor length

Loss diagram

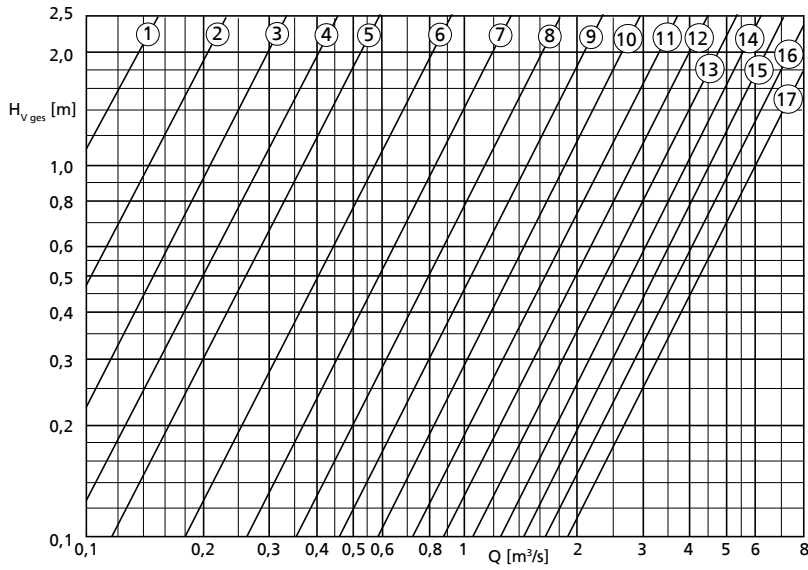

- ① - DN₂ = 200 mm
- ② - DN₂ = 250 mm
- ③ - DN₂ = 300 mm
- ④ - DN₂ = 350 mm
- ⑤ - DN₂ = 400 mm
- ⑥ - DN₂ = 500 mm
- ⑦ - DN₂ = 600 mm
- ⑧ - DN₂ = 700 mm
- ⑨ - DN₂ = 800 mm
- ⑩ - DN₂ = 900 mm
- ⑪ - DN₂ = 1000 mm
- ⑫ - DN₂ = 1100 mm
- ⑬ - DN₂ = 1200 mm
- ⑭ - DN₂ = 1300 mm
- ⑮ - DN₂ = 1400 mm
- ⑯ - DN₂ = 1500 mm
- ⑰ - DN₂ = 1600 mm

Calculation formulas:

$$H = H_{\text{geo}} + \Delta H_v$$

ΔH_v

- Loss in the riser (pipe friction)
- $H_{v \text{ ges.}}$ (see diagram)

$H_{v \text{ ges.}}$ comprises:

- Elbow
- Discharge pipe length = 5 x DN₂
- Swing check valve
- Outlet losses $v^2/2g$

Minimum water level diagram

Covered intake chamber

t_i [mm]

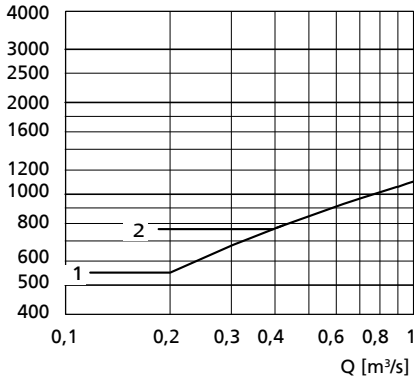

Key

- 1 - Amacan P 500-270
- 2 - Amacan P 600-350

CG type of installation (700-470 to 1600-1060)

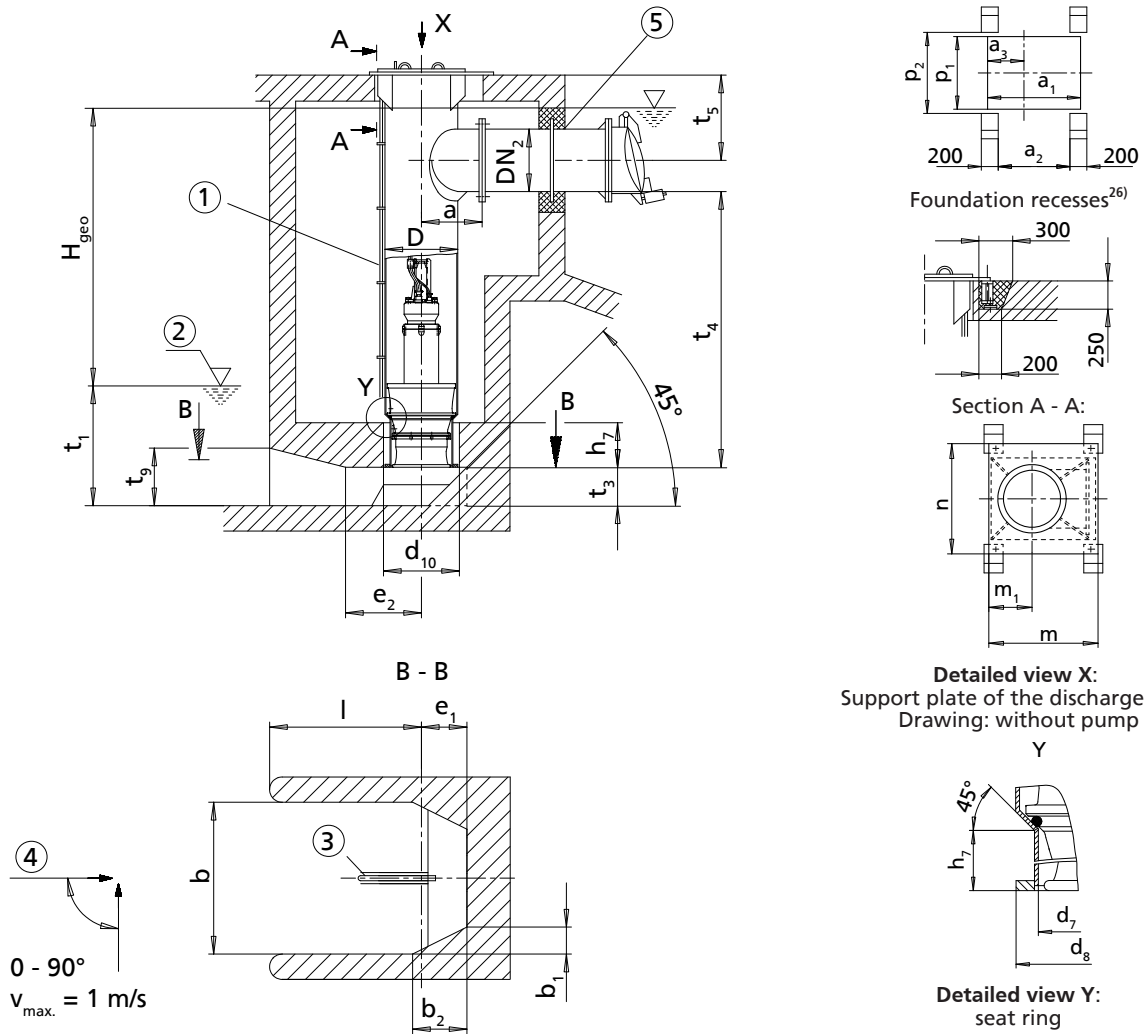

- ①: Vent line
- ②: Minimum water level (values see diagram on the following pages)
- ③: Flow-straightening vane (⇒ Page 35)
- ④: Approach flow
- ⑤: Connect the discharge pipe to the pump without transmitting any stresses or strains.

Dimensions [mm]

Size	DN _{2 min.}	DN _{2 max.}	D	a	a ₁ ²⁷⁾	a ₂ ²⁷⁾	a ₃ ²⁷⁾	b	b ₁	b ₂	d ₇	d ₈	d ₁₀
700 - 470	400	700	711	650	1120	870	430	1500	300	600	600	710	740
800 - 540	500	800	813	700	1220	970	480	1800	360	720	680	810	860
900 - 540	600	900	914	760	1320	1070	530	1800	360	720	700	910	960
1000 - 700	700	1000	1016	810	1430	1160	580	2300	460	920	880	1015	1080
1200 - 870	900	1200	1220	910	1630	1360	680	2800	560	1120	1070	1220	1290
1500 - 1060	1200	1500	1524	1060	1960	1690	850	3500	700	1400	1330	1520	1600
1600 - 1060	1300	1600	1625	1110	2080	1810	920	3500	700	1400	1420	1620	1700

Dimensions [mm]

Size	e ₁ ²⁸⁾	e ₂	h ₇	l _{min.}	m ²⁷⁾	m ₁ ²⁷⁾	n ²⁷⁾	p ₁ ²⁷⁾	p ₂ ²⁷⁾	t ₃ ²⁸⁾	t _{4 min.} ²⁹⁾	t _{5 min.} ²⁷⁾	t ₉
700 - 470	450	750	420	1500	1170	455	1260	960	1060	380	2400	770	570
800 - 540	519	900	525	1800	1270	505	1375	1075	1175	440	2450	835	660
900 - 540	519	900	515	1800	1380	560	1480	1180	1280	440	2650	925	660
1000 - 700	673	1150	765	2300	1520	625	1620	1280	1380	560	3250	980	850

26) All dimensions for foundation recesses apply to discharge tube design without intermediate flange.
 27) Designed for DN 2 max.
 28) Always observe this dimension.
 29) Value for maximum motor length

Size	e ₁ ²⁸⁾	e ₂	h ₇	l _{min.}	m ²⁷⁾	m ₁ ²⁷⁾	n ²⁷⁾	p ₁ ²⁷⁾	p ₂ ²⁷⁾	t ₃ ²⁸⁾	t _{4 min.} ²⁹⁾	t _{5 min.} ²⁷⁾	t ₉
1200 - 870	833	1400	1000	2800	1720	725	1850	1510	1610	680	4000	1100	1050
1500 - 1060	1048	1750	1460	3500	2050	895	2180	1840	1940	860	4050	1300	1320
1600 - 1060	1048	1750	1230	3500	2170	965	2280	1940	2040	860	4450	1380	1320

Permissible tolerances:

- Tolerances in building construction to DIN 18202, Part 4, Group B
- Welded design: B/F to DIN EN ISO 13920
- Tolerances for conical seat (detailed view Y): ISO 2768-mH
- Discharge flanges to DIN EN 1092-1 PN6 / DIN EN 1092-2 PN6

Loss diagram

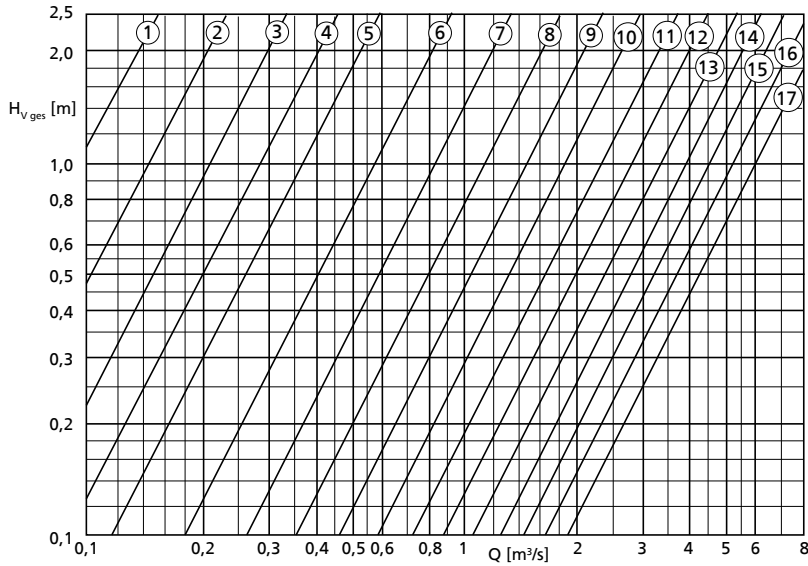

- ① - DN₂ = 200 mm
- ② - DN₂ = 250 mm
- ③ - DN₂ = 300 mm
- ④ - DN₂ = 350 mm
- ⑤ - DN₂ = 400 mm
- ⑥ - DN₂ = 500 mm
- ⑦ - DN₂ = 600 mm
- ⑧ - DN₂ = 700 mm
- ⑨ - DN₂ = 800 mm
- ⑩ - DN₂ = 900 mm
- ⑪ - DN₂ = 1000 mm
- ⑫ - DN₂ = 1100 mm
- ⑬ - DN₂ = 1200 mm
- ⑭ - DN₂ = 1300 mm
- ⑮ - DN₂ = 1400 mm
- ⑯ - DN₂ = 1500 mm
- ⑰ - DN₂ = 1600 mm

Calculation formulas:

$$H = H_{\text{geo}} + \Delta H_v$$

$$\Delta H_v$$

- Loss in the riser (pipe friction)
- H_{v ges.} (see diagram)

H_{v ges.} comprises:

- Elbow
- Discharge pipe length = 5 x DN₂
- Swing check valve
- Outlet losses v²/2g

Minimum water level diagram

Covered intake chamber

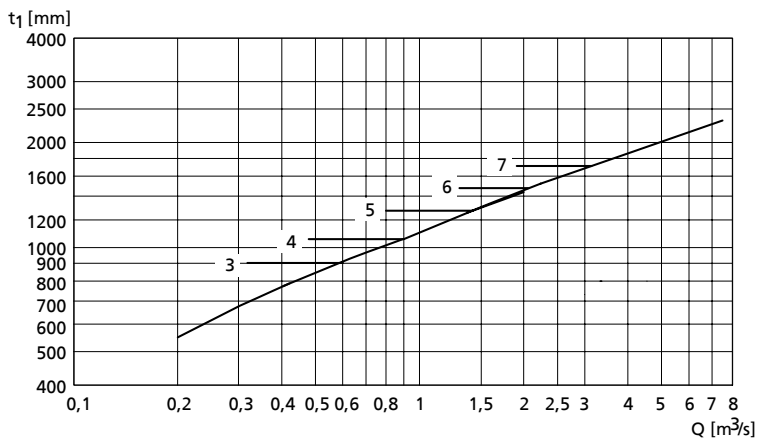

Key

- 3 - Amacan P 700 - 470
- 4 - Amacan P 800/900 - 540
- 5 - Amacan P 1000 - 700
- 6 - Amacan P 1200 - 870
- 7 - Amacan P 1500/1600 - 1060

DU type of installation (500-270 to 600-350)

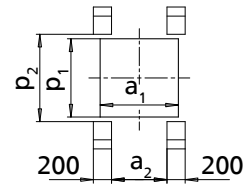
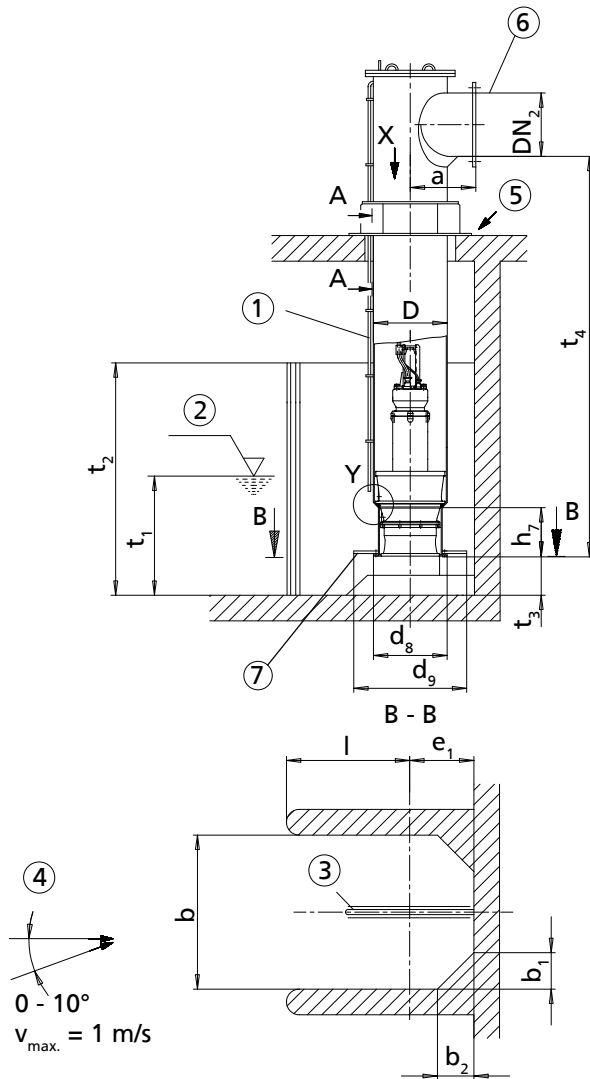

Foundation recesses³⁰⁾

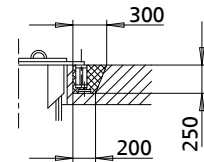

Section A - A:

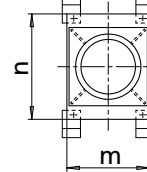

Detailed view X:
Support plate of the discharge tube
Drawing: without pump

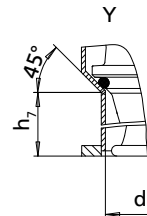

Detailed view Y:
seat ring

- ①: Vent line
- ②: Minimum water level (values see diagram on the following page)
- ③: Flow-straightening vane (⇒ Page 35)
- ④: Approach flow
- ⑤: Not pressure-proof
- ⑥ Connect the discharge pipe to the discharge tube without transmitting any stresses or strains.
- ⑦: Suction umbrella - Option for reducing the minimum water level t_1

Dimensions [mm]

Size	DN ₂ min.	DN ₂ max.	D	a	a ₁	a ₂	b	b ₁		b ₂	
								without suction umbrella d ₈	with suction umbrella d ₉	without suction umbrella d ₈	with suction umbrella d ₉
500 - 270	300	500	508	530	650	400	750	150	–	150	–
600 - 350	350	600	610	580	760	510	1250	250	–	250	–

30) All dimensions for foundation recesses apply to discharge tube design without intermediate flange.
31) Always observe this dimension.
32) Value for maximum motor length

Dimensions [mm]

Size	d ₇	d ₈	d ₉	e ₁ ³¹⁾		h ₇	l _{min.}	m	n	p ₁	p ₂	t ₃ ³¹⁾	t _{4 min.} ³²⁾
				without suction umbrella d ₈	with suction umbrella d ₉								
500 - 270	400	505	650	350	400	295	400	720	950	650	750	200	1700
600 - 350	500	610	800	400	500	540	850	830	1060	760	860	320	2000

t₂ = 1.1 x water level, maximum 2 x t₁
Height of corner lining (b₁ and b₂) like t₂

Permissible tolerances:

- Tolerances in building construction to DIN 18202, Part 4, Group B
- Welded design: B/F to DIN EN ISO 13920
- Tolerances for conical seat (detailed view Y): ISO 2768-mH
- Discharge flanges to DIN EN 1092-1 PN6 / DIN EN 1092-2 PN6

Loss diagram

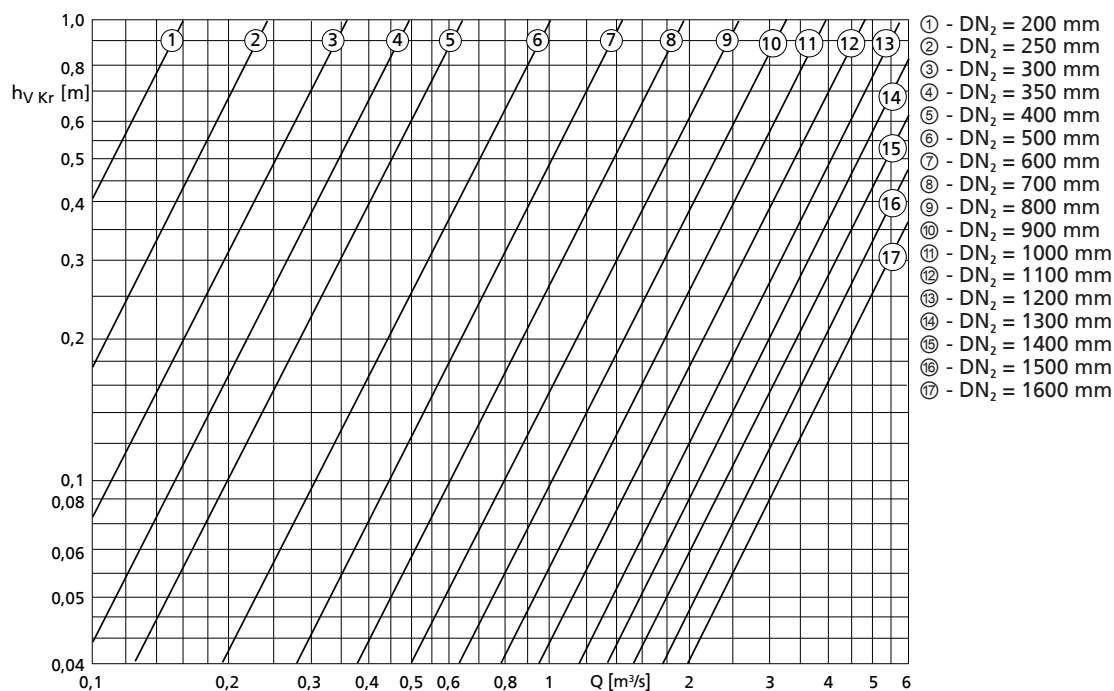

Calculation formulas:

$$H = H_{geo} + \Delta H_v$$

ΔH_v

- Loss in the elbow h_{v Kr} (see diagram)
- Loss in the riser (pipe friction)
- H_{v System} (valves, etc.)

H_{v System} must be determined for the specific system.

Minimum water level diagrams

Open intake chamber
(design without suction umbrella $\varnothing d_8$)

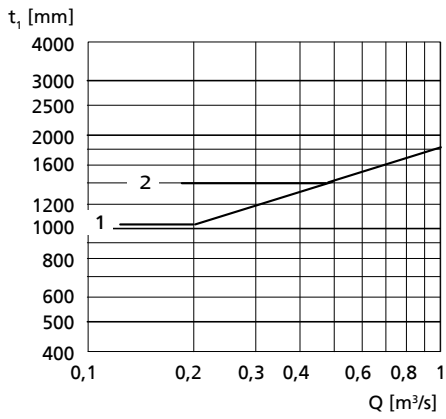

Open intake chamber
(design with suction umbrella $\varnothing d_9$)

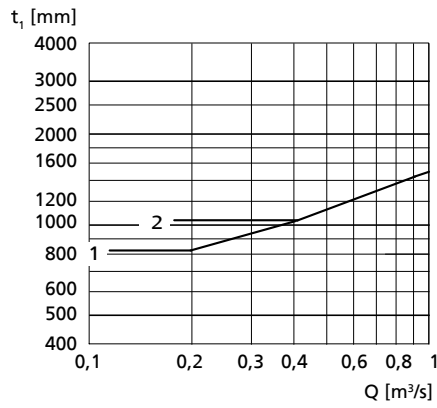

Key

- 1 - Amacan P 500-270
- 2 - Amacan P 600-350

DU type of installation (700-470 to 1600-1060)

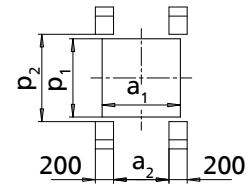
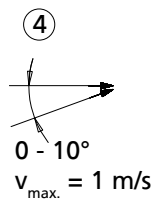
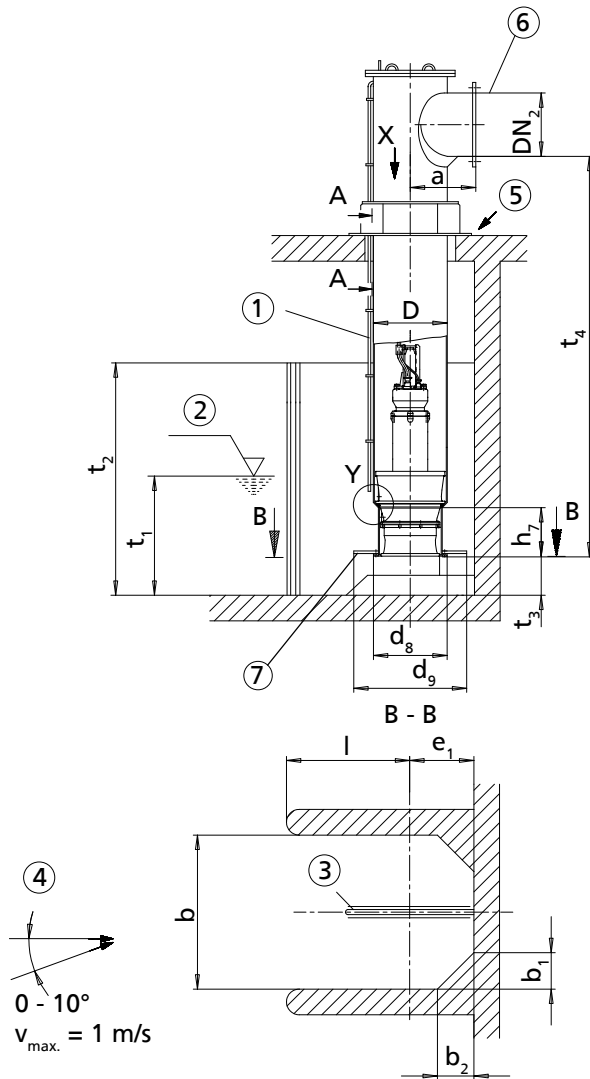

Foundation recesses³³⁾

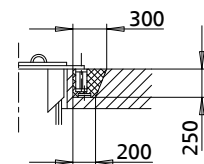

Section A - A:

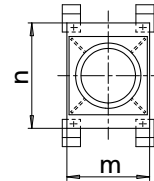

Detailed view X:

Support plate of the discharge tube
Drawing: without pump

Y

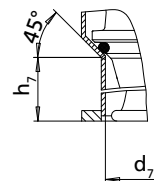

Detailed view Y:
seat ring

- ①: Vent line
- ②: Minimum water level (values see diagram on the following pages)
- ③: Flow-straightening vane (⇒ Page 35)
- ④: Approach flow
- ⑤: Not pressure-proof
- ⑥ Connect the discharge pipe to the discharge tube without transmitting any stresses or strains.
- ⑦: Suction umbrella - Option for reducing the minimum water level t_1

Dimensions [mm]

Size	DN ₂ min.	DN ₂ max.	D	a	a ₁	a ₂	b	b ₁		b ₂	
								Without suction umbrella d ₈	With suction umbrella d ₉	Without suction umbrella d ₈	With suction umbrella d ₉
700 - 470	400	700	711	650	860	610	1500	300	–	300	–
800 - 540	500	800	813	700	960	710	1800	360	–	360	–
900 - 540	600	900	914	760	1060	810	1800	360	–	360	–
1000 - 700	700	1000	1016	810	1160	910	2300	460	–	460	–
1200 - 870	900	1200	1220	910	1360	1110	2800	560	–	560	–
1500 - 1060	1200	1500	1524	1060	1670	1420	3500	700	–	700	–
1600 - 1060	1300	1600	1625	1110	1770	1520	3500	700	–	700	–

33) All dimensions for foundation recesses apply to discharge tube design without intermediate flange.
34) Always observe this dimension.
35) Value for maximum motor length

Dimensions [mm]

Size	d ₇	d ₈	d ₉	e ₁ ³⁴⁾		h ₇	l _{min.}	m	n	p ₁	p ₂	t ₃ ³⁴⁾	t _{4 min.} ³⁵⁾
				Without suction umbrella d ₈	With suction umbrella d ₉								
700 - 470	600	710	1100	450	650	420	1050	930	1160	860	960	380	2400
800 - 540	680	810	1250	500	700	525	1300	1030	1260	960	1060	440	2450
900 - 540	700	910	1250	550	700	515	1300	1130	1360	1060	1160	440	2650
1000 - 700	880	1015	1600	600	900	765	1700	1240	1500	1160	1260	560	3250
1200 - 870	1070	1220	2000	700	1100	1000	2100	1440	1700	1360	1460	680	4000
1500 - 1060	1330	1520	2450	850	1300	1460	2650	1760	2010	1670	1770	860	4050
1600 - 1060	1420	1620	2450	900	1300	1230	2600	1870	2130	1770	1870	860	4450

t₂ = 1.1 x water level, maximum 2 x t₁
Height of corner lining (b₁ and b₂) like t₂

Permissible tolerances:

- Tolerances in building construction to DIN 18202, Part 4, Group B
- Welded design: B/F to DIN EN ISO 13920
- Tolerances for conical seat (detailed view Y): ISO 2768-mH
- Discharge flanges to DIN EN 1092-1 PN6 / DIN EN 1092-2 PN6

Loss diagram

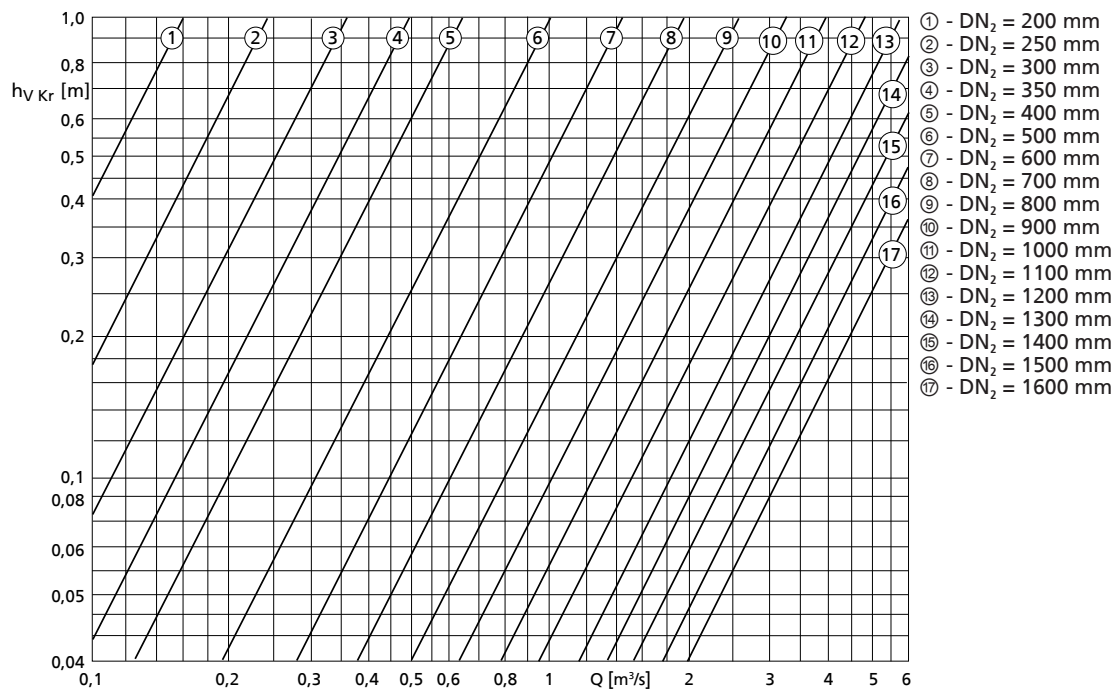

Calculation formulas:

$$H = H_{geo} + \Delta H_v$$

ΔH_v

- Loss in the elbow h_{v Kr} (see diagram)
- Loss in the riser (pipe friction)
- H_{v System} (valves, etc.)

H_{v System} must be determined for the specific system.

Minimum water level diagrams

Open intake chamber
(design without suction umbrella $\varnothing d_8$)

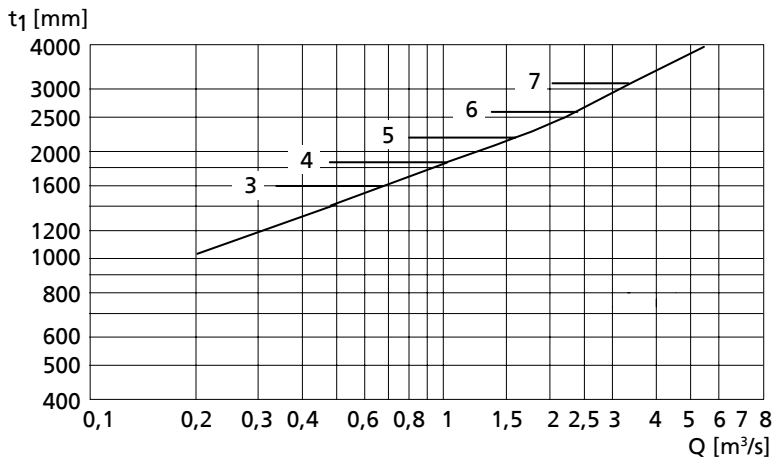

Key

- 3 - Amacan P 700 - 470
- 4 - Amacan P 800/900 - 540
- 5 - Amacan P 1000 - 700
- 6 - Amacan P 1200 - 870
- 7 - Amacan P 1500/1600-1060

Open intake chamber
(design with suction umbrella $\varnothing d_9$)

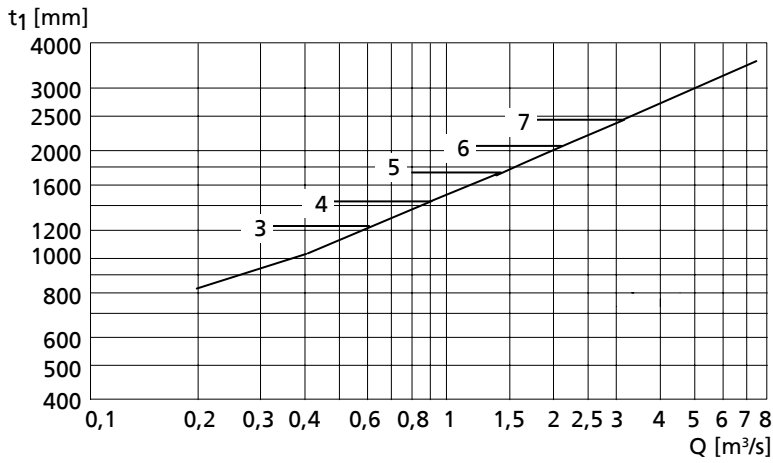

DG type of installation (500-270 to 600-350)

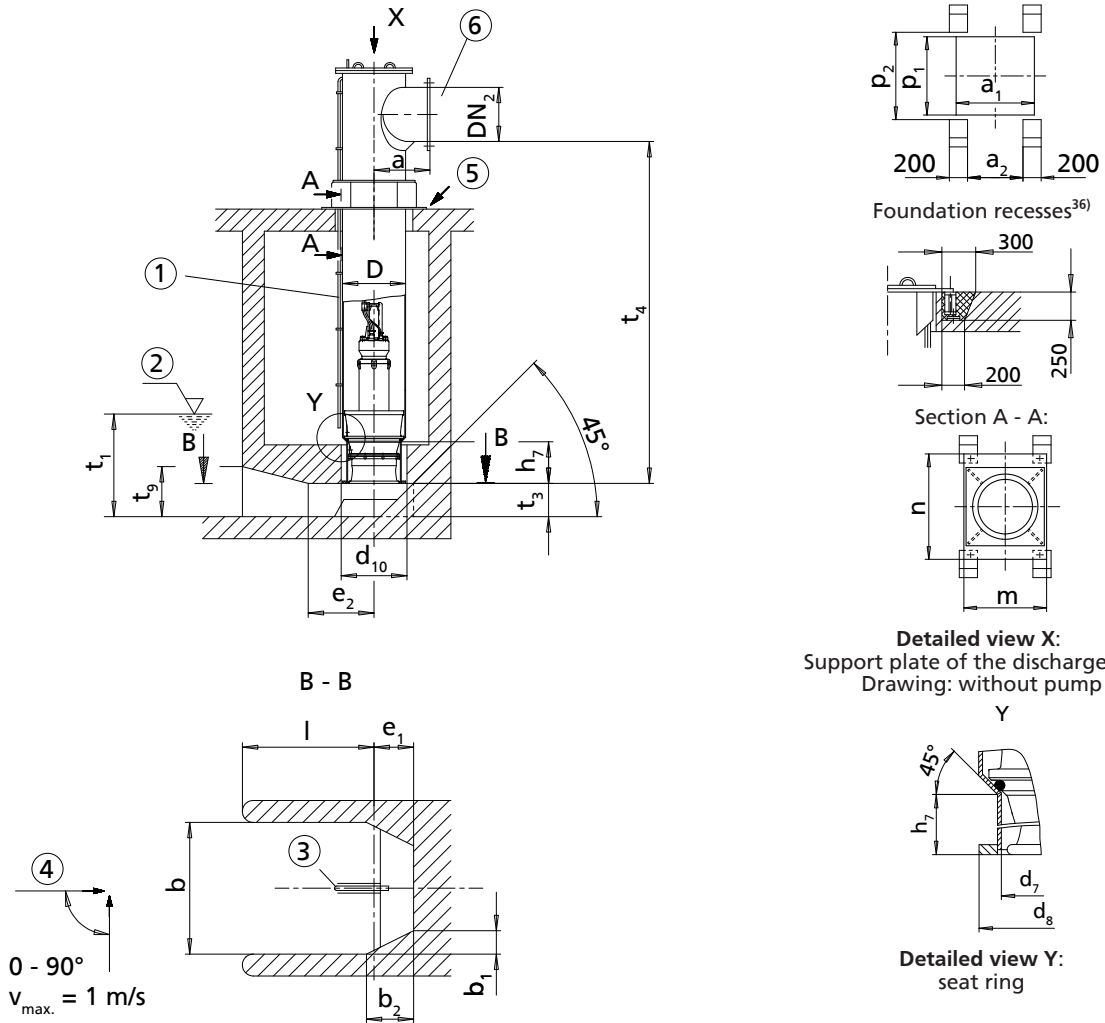

- ①: Vent line
- ②: Minimum water level (values see diagram on the next page)
- ③: Flow-straightening vane (⇒ Page 35)
- ④: Approach flow
- ⑤: Not pressure-proof
- ⑥: Connect the discharge pipe to the pump without transmitting any stresses or strains.

Dimensions [mm]

Size	DN _{2 min.}	DN _{2 max.}	D	a	a ₁	a ₂	b	b ₁	b ₂	d ₇	d ₈	d ₁₀
500 - 270	300	500	508	530	650	400	750	150	300	400	505	540
600 - 350	350	600	610	580	760	510	1250	250	500	500	610	640

Dimensions [mm]

Size	e ₁ ³⁷⁾	e ₂	h ₇	l _{min.}	m	n	p ₁	p ₂	t ₃ ³⁷⁾	t _{4 min.} ³⁸⁾	t ₉
500 - 270	259	375	295	750	720	950	650	750	200	1700	280
600 - 350	375	625	540	1250	830	1060	760	860	320	2000	470

Permissible tolerances:

- Tolerances in building construction to DIN 18202, Part 4, Group B
- Welded design: B/F to DIN EN ISO 13920
- Tolerances for conical seat (detailed view Y): ISO 2768-mH
- Discharge flanges to DIN EN 1092-1 PN6 / DIN EN 1092-2 PN6

36) All dimensions for foundation recesses apply to discharge tube design without intermediate flange.

37) Always observe this dimension.

38) Value for maximum motor length

Loss diagram

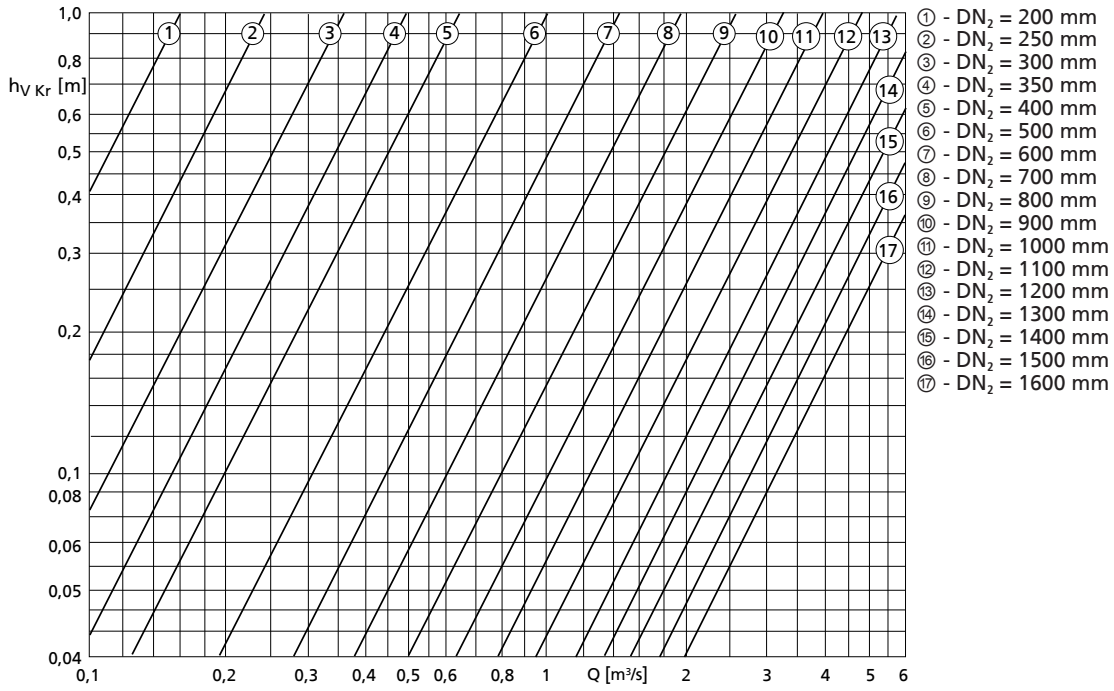

Calculation formulas:

$$H = H_{geo} + \Delta H_v$$

ΔH_v

- Loss in the elbow $h_{v,Kr}$ (see diagram)
- Loss in the riser (pipe friction)
- $H_{V,system}$ (valves, etc.)

$H_{V,system}$ must be determined for the specific system.

Minimum water level diagram

Covered intake chamber

t_i [mm]

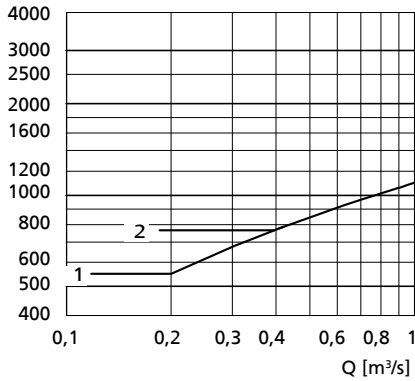

Key

- 1 - Amacan P 500-270
- 2 - Amacan P 600-350

DG type of installation (700-470 to 1600-1060)

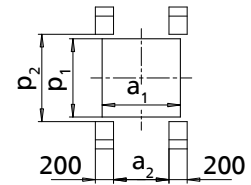
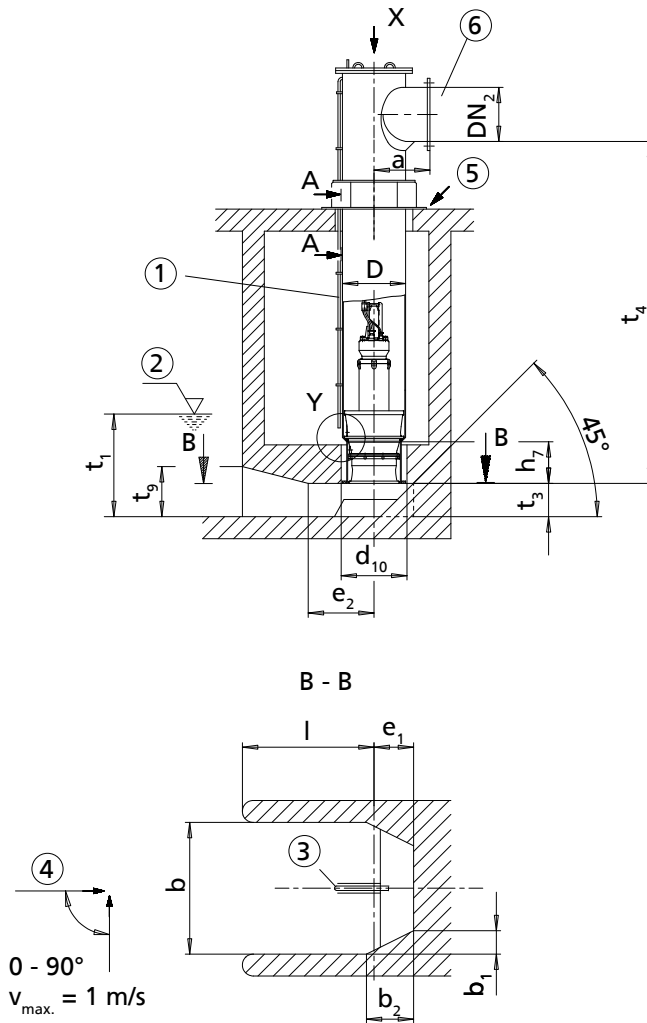

Foundation recesses³⁹⁾

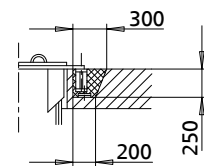

Section A - A:

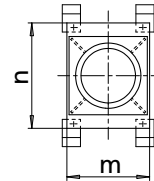

Detailed view X:

Support plate of the discharge tube
Drawing: without pump

Y

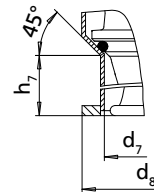

Detailed view Y:
seat ring

- ①: Vent line
- ②: Minimum water level (values see diagram on the following pages)
- ③: Flow-straightening vane (⇒ Page 35)
- ④: Approach flow
- ⑤: Not pressure-proof
- ⑥: Connect the discharge pipe to the pump without transmitting any stresses or strains.

Dimensions [mm]

Size	DN _{2 min.}	DN _{2 max.}	D	a	a ₁	a ₂	b	b ₁	b ₂	d ₇	d ₈	d ₁₀
700 - 470	400	700	711	650	860	610	1500	300	600	600	710	740
800 - 540	500	800	813	700	960	710	1800	360	720	680	810	860
900 - 540	600	900	914	760	1060	810	1800	360	720	700	910	960
1000 - 700	700	1000	1016	810	1160	910	2300	460	920	880	1015	1080
1200 - 870	900	1200	1220	910	1360	1110	2800	560	1120	1070	1220	1290
1500 - 1060	1200	1500	1524	1060	1670	1420	3500	700	1400	1330	1520	1600
1600 - 1060	1300	1600	1625	1110	1770	1520	3500	700	1400	1420	1620	1700

Dimensions [mm]

Size	e ₁ ⁴⁰⁾	e ₂	h ₇	l _{min.}	m	n	p ₁	p ₂	t ₃ ⁴⁰⁾	t _{4 min.} ⁴¹⁾	t ₉
700 - 470	450	750	420	1500	930	1160	860	960	380	2400	570
800 - 540	519	900	525	1800	1030	1260	960	1060	440	2450	660
900 - 540	519	900	515	1800	1130	1360	1060	1160	440	2650	660
1000 - 700	673	1150	765	2300	1240	1500	1160	1260	560	3250	850

39) All dimensions for foundation recesses apply to discharge tube design without intermediate flange.

40) Always observe this dimension.

41) Value for maximum motor length

Size	e ₁ ⁴⁰⁾	e ₂	h ₇	l _{min.}	m	n	p ₁	p ₂	t ₃ ⁴⁰⁾	t _{4 min.} ⁴¹⁾	t ₉
1200 - 870	833	1400	1000	2800	1440	1700	1360	1460	680	4000	1050
1500 - 1060	1048	1750	1460	3500	1760	2010	1670	1770	860	4050	1320
1600 - 1060	1048	1750	1230	3500	1870	2130	1770	1870	860	4450	1320

Permissible tolerances:

- Tolerances in building construction to DIN 18202, Part 4, Group B
- Welded design: B/F to DIN EN ISO 13920
- Tolerances for conical seat (detailed view Y): ISO 2768-mH
- Discharge flanges to ISO 7005/2, DIN 2501 PN6

Loss diagram

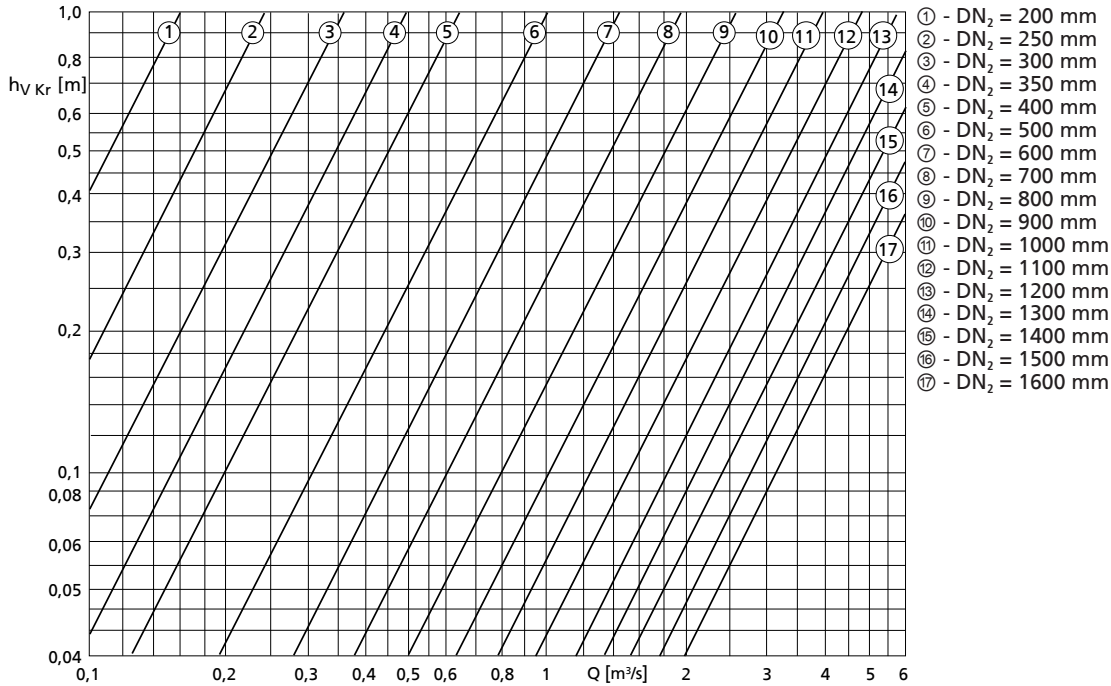

Calculation formulas:

$$H = H_{geo} + \Delta H_v$$

ΔH_v

- Loss in the elbow h_{vKr} (see diagram)
- Loss in the riser (pipe friction)
- $H_{V,system}$ (valves, etc.)

$H_{V,system}$ must be determined for the specific system.

Minimum water level diagram

Covered intake chamber

t₁ [mm]

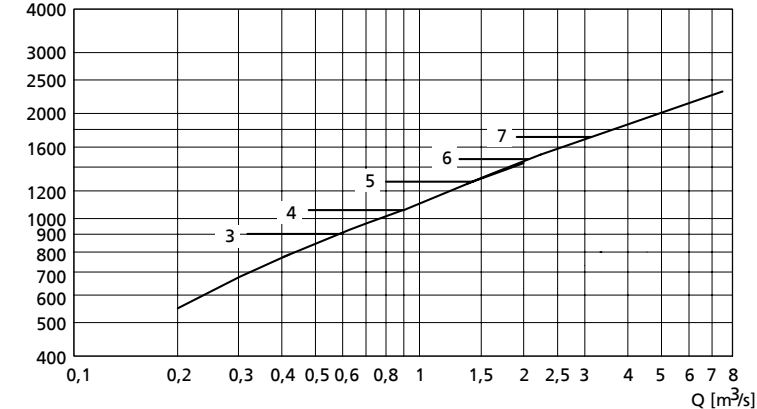

Key

- 3 - Amacan P 700 - 470
- 4 - Amacan P 800/900 - 540
- 5 - Amacan P 1000 - 700
- 6 - Amacan P 1200 - 870
- 7 - Amacan P 1500/1600 - 1060

Dimensions of the flow-straightening vane

Design of the intake chamber wall surfaces (to prevent vortex formation)

The flow-straightening vane is indispensable for the inlet conditions of the pump set. It prevents the development of a submerged vortex (floor vortex) which could cause a drop in performance, for example. In addition, the floor and wall surfaces of the intake chamber should be designed as a rough concrete surface. Rough surfaces minimise the separation of boundary layers that may cause wall and floor vortices.

Flow-straightening vane and intake chamber

- The anti-vortex vanes in the bellmouth must be aligned with the flow-straightening vane.
- The bail of the pump is oriented in the same direction as the anti-swirl baffles in the bellmouth.

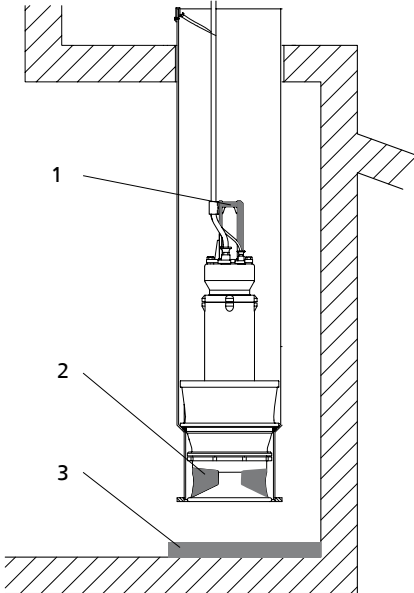
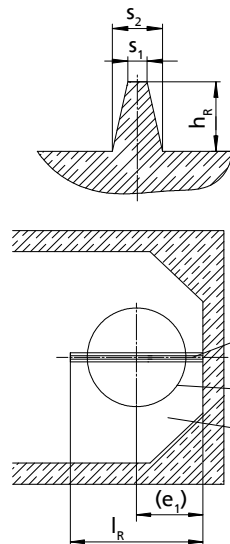

Fig. 1: Installation position of the pump set

1	Bail
2	Anti-vortex vanes
3	Flow-straightening vane

Variant 1
Flow-straightening vane cast from concrete



Variant 2
Steel section

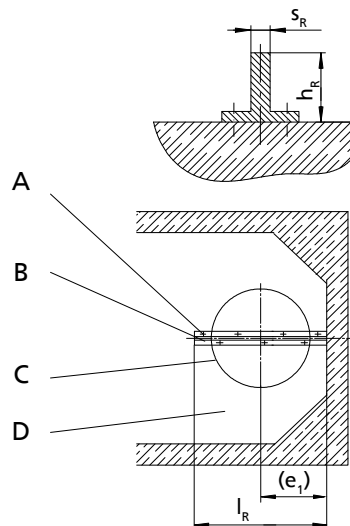

A	Bolted to the floor of the intake chamber
B	Flow-straightening vane centred beneath the discharge tube
C	Discharge tube
D	Intake chamber

Installation types BU, CU, DU

Dimensions [mm]

Size	h_R	s_1	s_2	s_R	(e_1)		l_R	
					Design without suction umbrella d_8	Design with suction umbrella d_9	Design without suction umbrella d_8	Design with suction umbrella d_9
500 - 270	120	15	60	10	350	400	670	720
600 - 350	190	20	70	10	400	500	875	940
700 - 470	230	25	90	10	450	650	1000	1200
800 - 540	265	25	100	12	500	700	1165	1300
900 - 540	265	25	100	12	550	700	1165	1300
1000 - 700	335	30	120	12	600	900	1375	1675
1200 - 870	410	30	120	12	700	1100	1650	2050
1500 - 1060	515	40	140	12	850	1300	2050	2500
1600 - 1060	515	40	140	12	900	1300	2050	2500

Dimensions for installation types BG, CG, DG

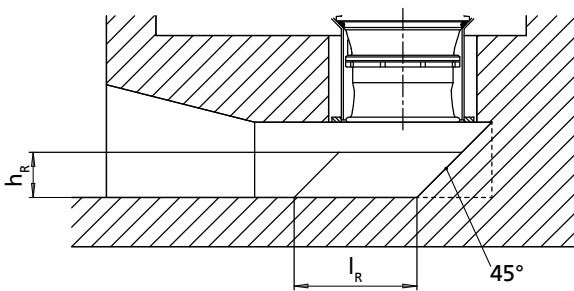

Fig. 2: Flow-straightening vane for covered intake chamber

Dimensions [mm]

Size	h_R	s_1	s_2	s_R	l_R
500 - 270	120	15	60	10	430
600 - 350	190	20	70	10	545
700 - 470	230	25	90	10	650
800 - 540	265	25	100	12	740
900 - 540	265	25	100	12	790
1000 - 700	335	30	120	12	940
1200 - 870	410	30	120	12	1150
1500 - 1060	515	40	140	12	1450
1600 - 1060	515	40	140	12	1500



KSB SE & Co. KGaA
Turmstraße 92 • 06110 Halle (Germany)
Tel. +49 345 4826-0
www.ksb.com