

Submersible Pump in Discharge Tube

Amacan S

50 Hz

General Arrangement Drawings



Legal information/Copyright

General Arrangement Drawings Amacan S

All rights reserved. The contents provided herein must neither be distributed, copied, reproduced, edited or processed for any other purpose, nor otherwise transmitted, published or made available to a third party without the manufacturer's express written consent.

Subject to technical modification without prior notice.

© KSB SE & Co. KGaA, Frankenthal 12/02/2018

Contents

Water Applications: Water Transport 4

- Submersible Pump in Discharge Tube..... 4
- Amacan S 4
 - Designation 4
 - Selection information 4
 - Installation types 5
 - General arrangement drawings 6
 - Installation type BU (Amacan S 650-364 to 800-505) 6
 - Installation type BU (Amacan S 800-535 to 1300-820) 9
 - Installation type BG (Amacan S 650-364 to 800-505) 12
 - Installation type BG (Amacan S 800-535 to 1300-820) 14
 - Installation type CU (Amacan S 650-364 to 800-505) 17
 - Installation type CU (Amacan S 800-535 to 1300-820) 20
 - Installation type CG (Amacan S 650-364 to 800-505) 23
 - Installation type CG (Amacan S 800-535 to 1300-820) 26
 - Installation type DU (Amacan S 650-364 to 800-505) 29
 - Installation type DU (Amacan S 800-535 to 1300-820) 32
 - Installation type DG (Amacan S 650-364 to 800-505) 35
 - Installation type DG (Amacan S 800-535 to 1300-820) 38
 - Dimensions of the flow-straightening vane 41

Water Applications: Water Transport

Submersible Pump in Discharge Tube

Amacan S



Designation

Example: Amacan S 1000-655 / 250 8 UTG2

Key to the designation

Code	Description	
Amacan	Type series	
S	Impeller type, e.g. S = mixed flow impeller	
1000	Nominal diameter of the discharge tube [mm]	
655	Nominal impeller diameter [mm]	
250	Motor size	
8	Number of motor poles	
	4	4-pole
	6	6-pole
	8	8-pole
UT	Motor version	
	UT	
	UA	
G2	Material variant	
	G2	
	G3	

Selection information

Information on pump selection

The guaranteed point for submersible pumps in discharge tube is 0.5 m above the motor (DIN 1184). The documented characteristic curves are based on this reference level. This must be taken into account when calculating system losses. The heads and performance data apply to pumped fluids with a density $\rho = 1 \text{ kg/dm}^3$ and a kinematic viscosity ν of up to $20 \text{ mm}^2/\text{s}$.

Intake chamber

Determine the minimum water level t_{min} (diagram in general arrangement drawing):
The minimum water level t_{min} is the water level required in the pump's suction chamber to ensure:

- that there is a sufficient liquid cover above the hydraulic system (propeller) (shown in diagram depending on pump size)
- that the pump does not draw in air-entraining vortices (shown in diagram depending on flow rate)
- that there is no cavitation in the hydraulic system (check against the $\text{NPSH}_{\text{required}}$ value indicated in the technical literature). The following conditions must be met:
 - $\text{NPSH}_{\text{available}} > \text{NPSH}_{\text{required}} + \text{safety allowance}$
 - $\text{NPSH}_{\text{available}} = 10.0 + (t_1 - t_3 - h_7/2)$
 - Safety allowance:
up to $Q_{\text{opt}} \Rightarrow 0.5 \text{ m}$
larger than $Q_{\text{opt}} \Rightarrow 1.0 \text{ m}$

Head (H)

The total pump head is composed as follows:

$$H = H_{\text{geo}} + \Delta H_v$$

H_{geo} (static head)

- Without discharge elbow – Difference between suction-side water level and overflow edge
- With discharge elbow – Difference between suction-side and discharge-side water level

ΔH_v (losses in the system)

- Starting 0.5 m downstream of the pump: e.g. pipe friction, elbow, swing check valve, etc.

Internal losses

Losses caused by the inlet, riser and elbow (or free discharge).

- Riser losses up to the above mentioned reference level (0.5 m above the motor) are contained in the documented characteristic curves.
- Inlet and elbow losses are system losses and must be taken into account for selection.
- For information on structural requirements, pump installation and pump sump design please refer to the KSB know-how brochure "Planning information: Amacan submersible pumps in discharge tubes" 0118.55.

Installation types

Six design variants are available, depending on the installation type:¹⁾

Installation types

<p>BU discharge tube Design with above floor discharge outlet for installation in open intake chamber</p>	<p>BG discharge tube Design with above floor discharge outlet for installation in covered intake chamber, for low suction-side water levels</p>
<p>CU discharge tube Design with underfloor discharge outlet for installation in open intake chamber</p>	<p>CG discharge tube Design with underfloor discharge outlet for installation in covered intake chamber, for low suction-side water levels</p>
<p>DU discharge tube Design with above floor discharge nozzle for installation in open intake chamber</p>	<p>DG discharge tube Design with above floor discharge nozzle for installation in covered intake chamber, for low suction-side water levels</p>

1) For information on the different installation types (foundation dimensions, intake chamber, etc.) see general arrangement drawings

General arrangement drawings

Installation type BU (Amacan S 650-364 to 800-505)

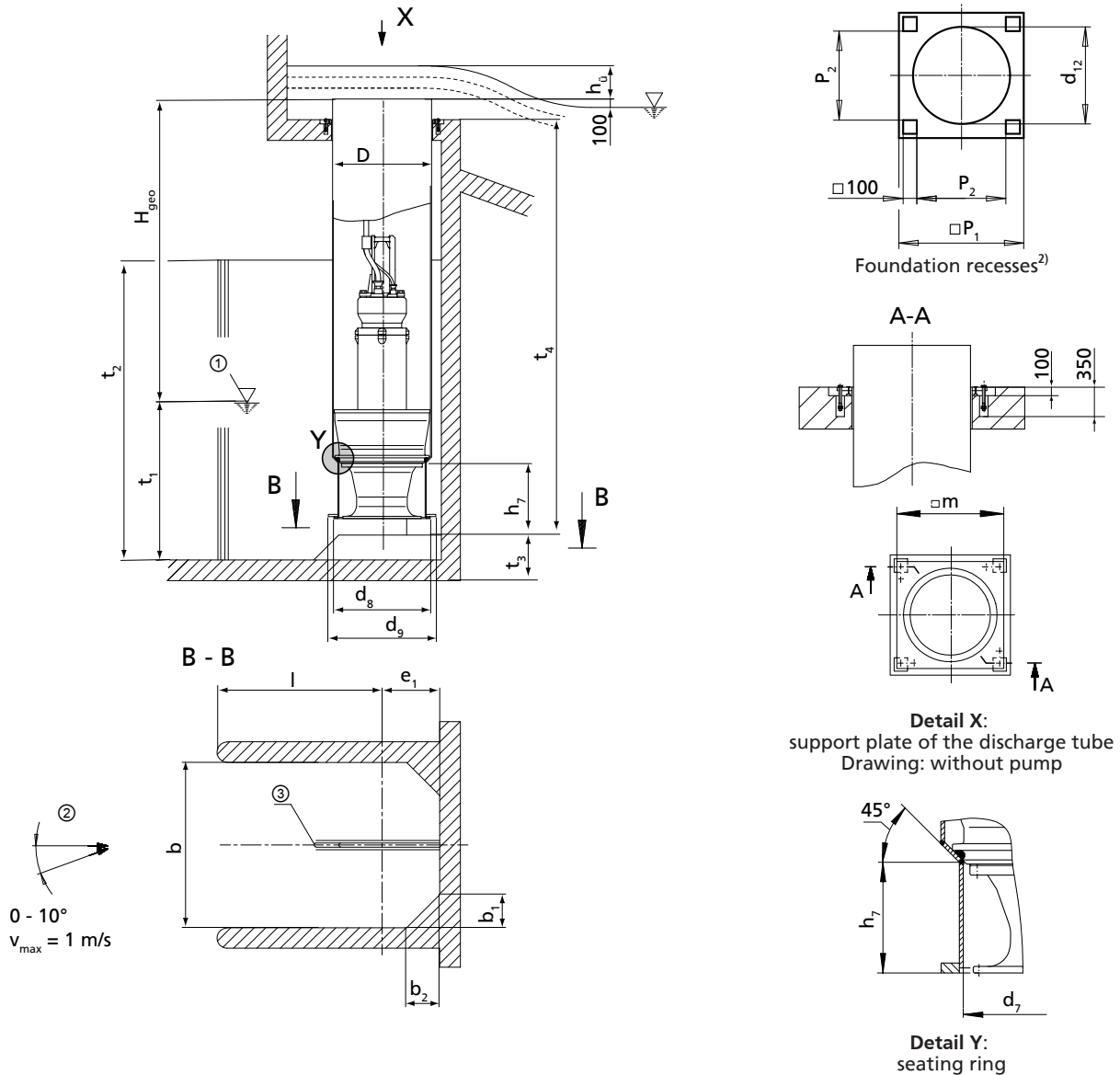

Dimensions [mm]

Size	D	b	b ₁		b ₂		d ₇	d ₈	d ₉	d ₁₂
			without suction umbrella d ₈	with suction umbrella d ₉	without suction umbrella d ₈	with suction umbrella d ₉				
650 - 364	660	1000	200	–	200	–	530	660	900	700
650 - 365	660	1000	200	–	200	–	530	660	900	700
650 - 404	660	1000	200	–	200	–	530	660	900	700
650 - 405	660	1250	250	–	250	–	530	660	900	700
800 - 505	813	1250	250	–	250	–	680	810	1050	850

- 2) All dimensions for foundation recesses apply to discharge tube design without intermediate flange.
 3) Always observe this dimension.
 4) Value for maximum motor length

Dimensions [mm]

Size	e ₁ ³⁾		h ₇	l _{min.}	m	p ₁	p ₂	t ₃ ³⁾	t _{4 min.} ⁴⁾
	without suction umbrella d ₈	with suction umbrella d ₉							
650 - 364	420	540	225	580	750	850	590	260	2350
650 - 365	420	540	225	580	750	850	590	260	2350
650 - 404	420	540	265	580	750	850	590	260	2560
650 - 405	420	540	265	830	750	850	590	320	2720
800 - 505	500	620	335	750	910	1000	740	320	2660

t₂ = 1.1 x water level; max. 2 x t₁ (depending on head H and structure)
Height of corner lining (b₁ and b₂) equals t₂

Permissible tolerances:

- Tolerances in building construction to DIN 18202, Part 4, Group B
- Welded constructions: B/F to DIN EN ISO 13920
- Tolerances for conical seat (detail Y): ISO 2768-mH

Loss diagram

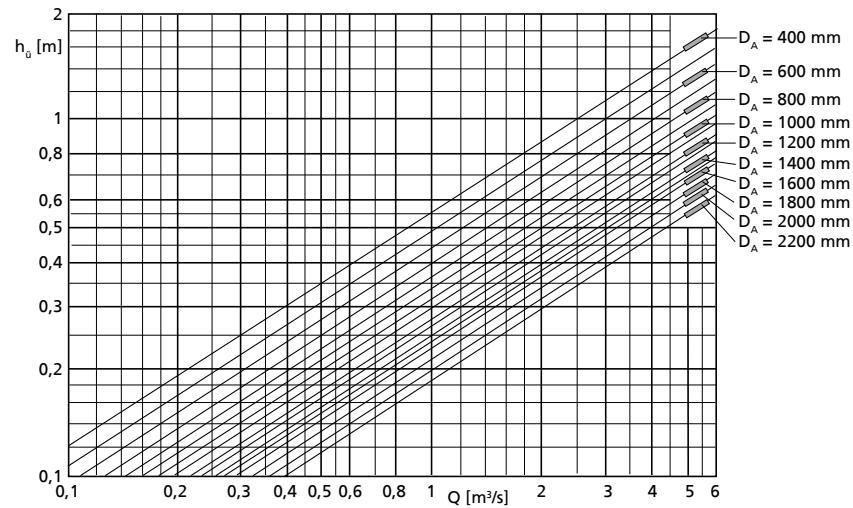
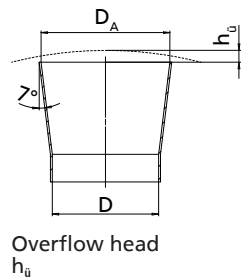

Loss diagram

Calculation formulas:

$$H = H_{geo} + \Delta H_v$$

$$\Delta H_v$$

- Overflow head h_i (see diagram)
- Loss in the riser (pipe friction)
- Outlet loss v²/2 g (v refers to D_A)

Overflow head h_i depends on Q and the discharge diameter D_A. The characteristic curve values only apply to unimpeded outlet in all directions; otherwise they are approximate values only.

Minimum water level diagram

Open chamber

t_1 [mm]

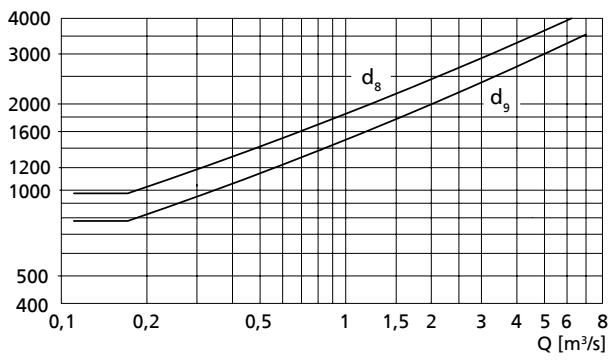

Minimum water level

d_8 = Design: **without** suction umbrella (standard)

d_9 = Design: **with** suction umbrella

Installation type BU (Amacan S 800-535 to 1300-820)

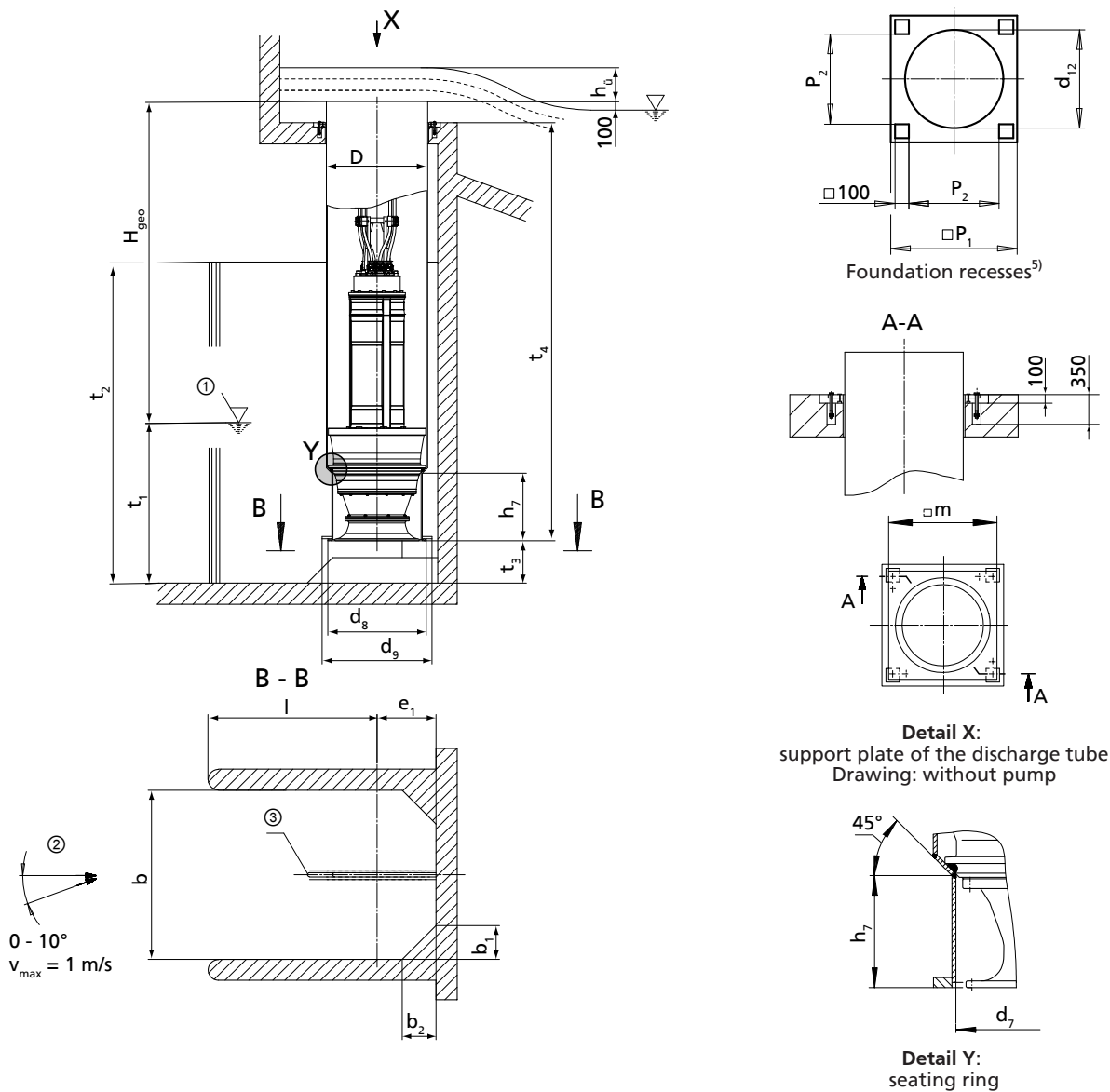

Dimensions [mm]

Size	D	b	b ₁		b ₂		d ₇	d ₈	d ₉	d ₁₂
			without suction umbrella d ₈	with suction umbrella d ₉	without suction umbrella d ₈	with suction umbrella d ₉				
800 - 535	813	1500	300	-	300	-	720	810	1300	850
850 - 535	868	1500	300	-	300	-	720	865	1300	920
850 - 550	868	1500	300	-	300	-	740	865	1300	920
900 - 600	914	1500	300	-	300	-	800	910	1300	970
900 - 615	914	1800	360	-	360	-	780	910	1300	970
900 - 620	914	1250	250	-	250	-	770	910	1050	970
1000 - 600	1016	1500	300	-	300	-	800	1015	1300	1070
1000 - 615	1016	1800	360	-	360	-	780	1015	1300	1070

5) All dimensions for foundation recesses apply to discharge tube design without intermediate flange.

Size	D	b	b ₁		b ₂		d ₇	d ₈	d ₉	d ₁₂
			without suction umbrella d ₈	with suction umbrella d ₉	without suction umbrella d ₈	with suction umbrella d ₉				
1000 - 620	1016	1250	250	-	250	-	770	1015	1050	1070
1000 - 655	1016	1800	360	-	360	-	920	1015	1500	1070
1300 - 820	1320	2300	460	-	460	-	1080	1320	1800	1380

Dimensions [mm]

Size	e ₁ ⁶⁾		h ₇	l _{min.}	m	p ₁	p ₂	t ₃ ⁶⁾	t _{4 min.} ⁷⁾
	without suction umbrella d ₈	with suction umbrella d ₉							
800 - 535	500	750	325	1000	910	1000	740	380	2800
850 - 535	525	750	325	975	980	1050	790	380	3210
850 - 550	525	750	375	975	980	1050	790	380	3250
900 - 600	550	750	415	950	1050	1120	860	380	3200
900 - 615	550	750	420	1250	1050	1120	860	440	3200
900 - 620	550	620	365	700	1050	1120	860	320	3200
1000 - 600	600	750	415	900	1150	1220	960	380	3650
1000 - 615	600	750	420	1200	1150	1220	960	440	3650
1000 - 620	600	620	365	650	1150	1220	960	320	3650
1000 - 655	600	850	515	1200	1150	1220	960	440	3750
1300 - 820	750	1000	545	1550	1460	1520	1260	560	3900

t₂ = 1.1 x water level; max. 2 x t₁ (depending on head H and structure)
Height of corner lining (b₁ and b₂) equals t₂

Permissible tolerances:

- Tolerances in building construction to DIN 18202, Part 4, Group B
- Welded constructions: B/F to DIN EN ISO 13920
- Tolerances for conical seat (detail Y): ISO 2768-mH

Loss diagram

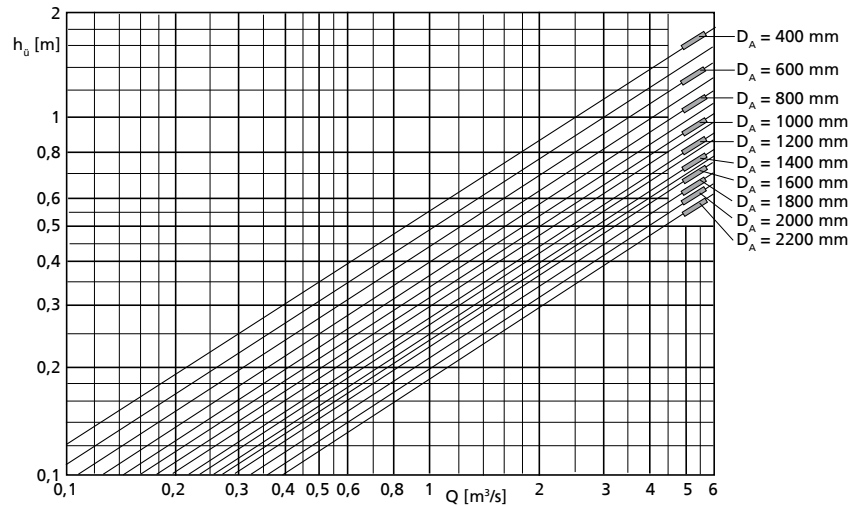
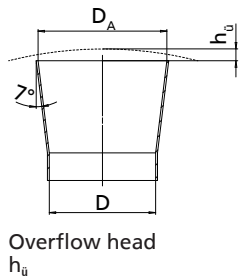

6) Always observe this dimension.
7) Value for maximum motor length

Calculation formulas:

$$H = H_{\text{geo}} + \Delta H_v$$

ΔH_v

- Overflow head $h_{\text{ü}}$ (see diagram)
- Loss in the riser (pipe friction)
- Outlet loss $v^2/2g$ (v refers to D_A)

Overflow head $h_{\text{ü}}$ depends on Q and the discharge diameter D_A . The characteristic curve values only apply to unimpeded outlet in all directions; otherwise they are approximate values only.

Minimum water level diagram

Open chamber

t_1 [mm]

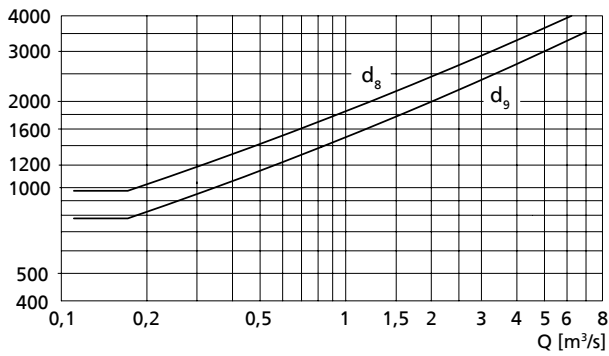

Minimum water level

d_8 = Design: **without** suction umbrella (standard)

d_9 = Design: **with** suction umbrella

Installation type BG (Amacan S 650-364 to 800-505)

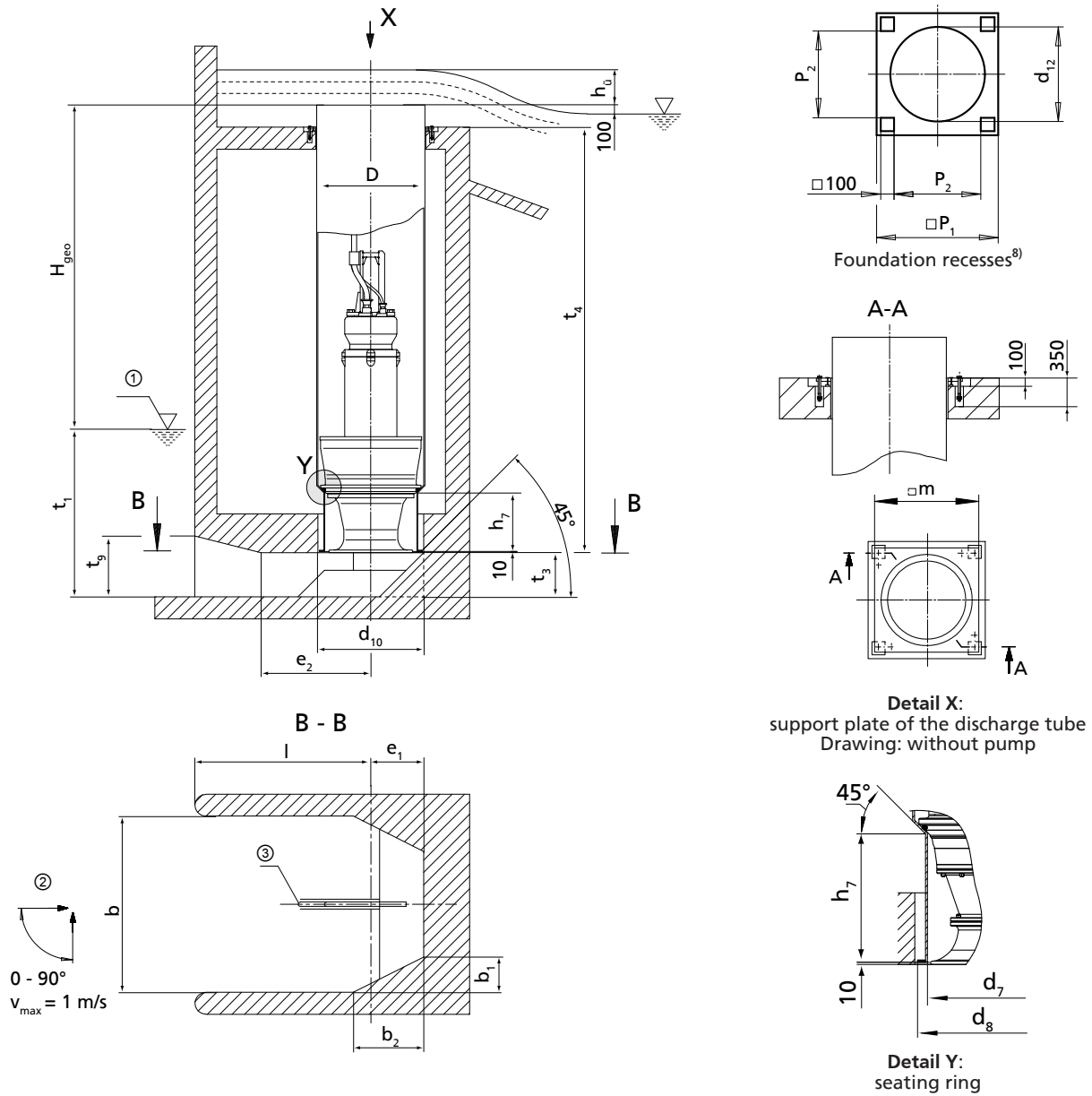

- ①: Minimum water level (values see diagram on the next page),
- ②: Approach flow,
- ③: Flow-straightening vane (⇒ Page 41)

Dimensions [mm]

Size	D	b	b ₁	b ₂	d ₇	d ₈	d ₁₀	d ₁₂	e ₁ ⁹⁾
650 - 364	660	1000	200	400	530	550	600	700	300
650 - 365	660	1000	200	400	530	550	600	700	300
650 - 404	660	1000	200	400	530	550	600	700	300
650 - 405	660	1250	250	500	530	660	690	700	375
800 - 505	813	1250	250	500	680	700	735	850	375

8) All dimensions for foundation recesses apply to discharge tube design without intermediate flange.
9) Always observe this dimension.
10) Value for maximum motor length

Dimensions [mm]

Size	e ₂	h ₇	l _{min}	m	p ₁	p ₂	t ₃ ⁹⁾	t _{4 min} ¹⁰⁾	t ₉
650 - 364	500	225	1000	750	850	590	260	2350	375
650 - 365	500	225	1000	750	850	590	260	2350	375
650 - 404	500	265	1000	750	850	590	260	2560	375
650 - 405	625	265	1250	750	850	590	320	2720	470
800 - 505	625	335	1250	910	1000	740	320	2660	470

Permissible tolerances:

- Tolerances in building construction to DIN 18202, Part 4, Group B
- Welded constructions: B/F to DIN EN ISO 13920
- Tolerances for conical seat (detail Y): ISO 2768-mH

Loss diagram

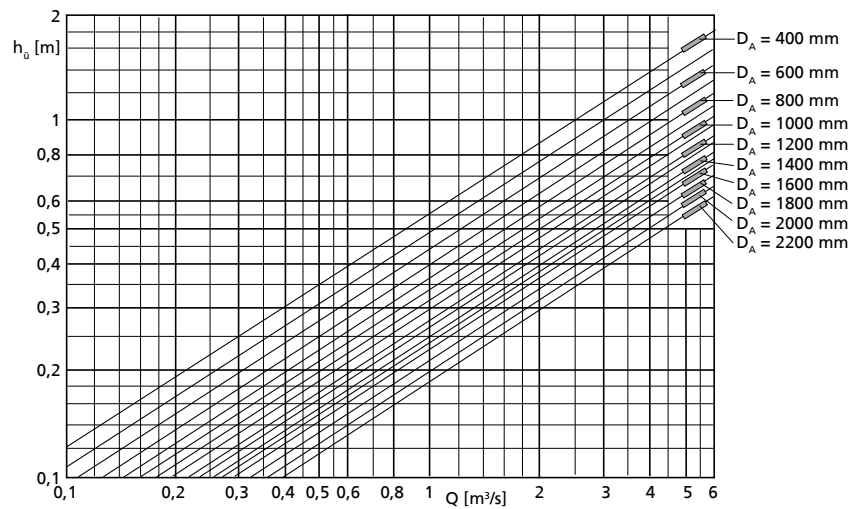
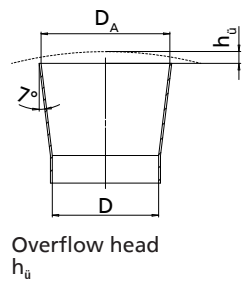

Calculation formulas:

$$H = H_{geo} + \Delta H_v$$

- ΔH_v
- Overflow head h_i (see diagram)
 - Loss in the riser (pipe friction)
 - Outlet loss $v^2/2 g$ (v refers to D_A)

Overflow head h_i depends on Q and the discharge diameter D_A . The characteristic curve values only apply to unimpeded outlet in all directions; otherwise they are approximate values only.

Minimum water level diagram

Covered chamber

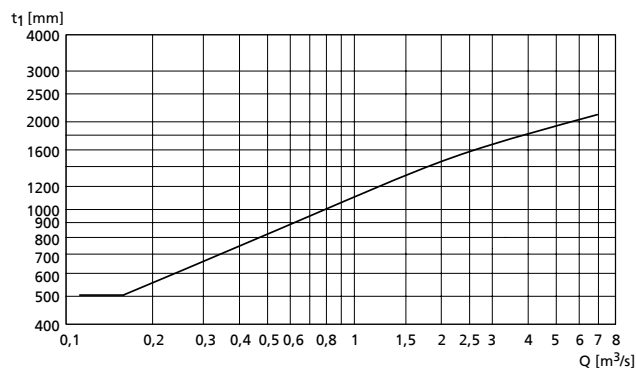

Installation type BG (Amacan S 800-535 to 1300-820)

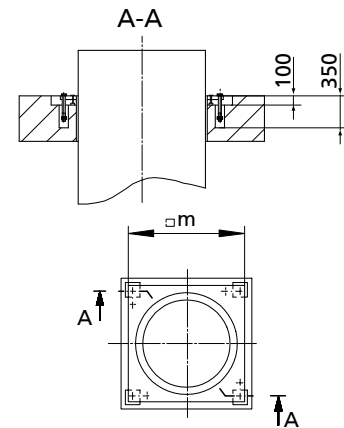
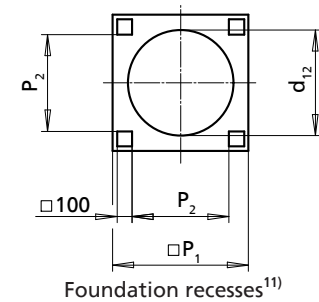
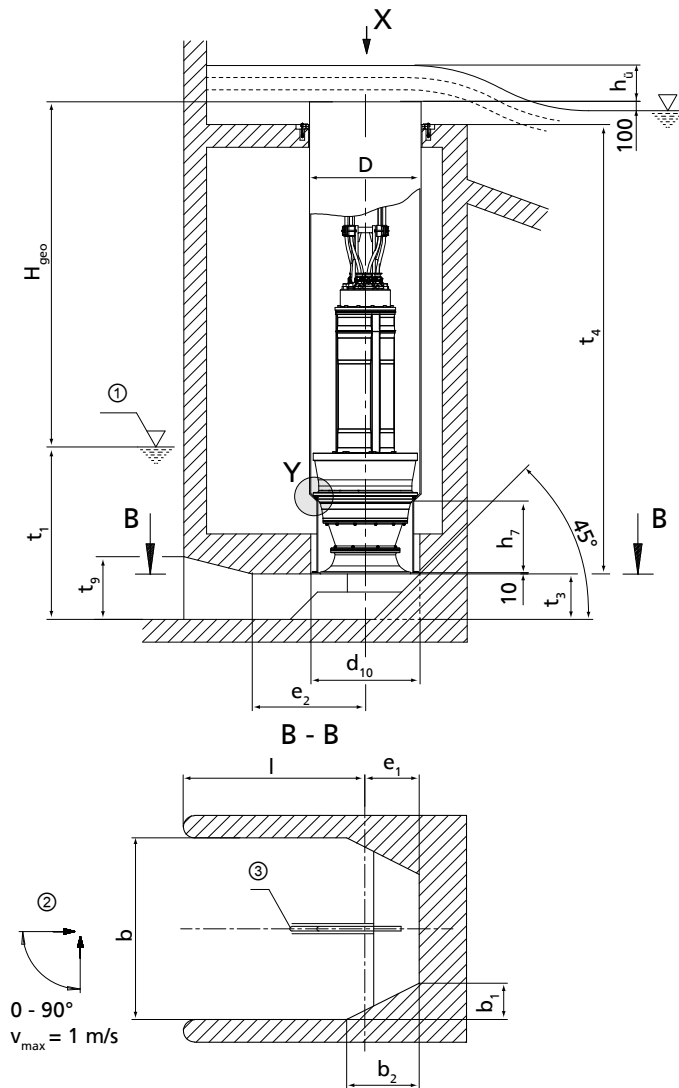

Detailed view X:
Support plate of the discharge tube
Drawing: without pump

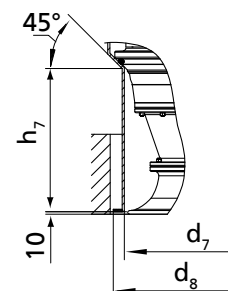

Detailed view Y:
seating ring

- ①: Minimum water level (values see diagram on the next page),
- ②: Approach flow,
- ③: Flow-straightening vane (⇒ Page 41)

Dimensions [mm]

Size	D	b	b ₁	b ₂	d ₇	d ₈	d ₁₀	d ₁₂	e ₁ ¹²⁾
800 - 535	813	1500	300	600	720	840	885	850	450
850 - 535	868	1500	300	600	720	840	885	920	450
850 - 550	868	1500	300	600	740	840	885	920	450
900 - 600	914	1500	300	600	800	820	860	970	450
900 - 615	914	1800	360	720	780	910	955	970	520
900 - 620	914	1250	250	500	770	790	830	970	415
1000 - 600	1016	1500	300	600	800	820	860	1070	450
1000 - 615	1016	1800	360	720	780	1000	1040	1070	520
1000 - 620	1016	1250	250	500	770	790	830	1070	415
1000 - 655	1016	1800	360	720	920	1000	1040	1070	520
1300 - 820	1320	2300	460	920	1080	1300	1360	1380	680

11) All dimensions for foundation recesses apply to discharge tube design without intermediate flange.
12) Always observe this dimension.

Dimensions [mm]

Size	e ₂	h ₇	l _{min}	m	p ₁	p ₂	t ₃ ¹²⁾	t _{4 min} ¹³⁾	t ₉
800 - 535	750	325	1500	910	1000	740	380	2800	570
850 - 535	750	325	1500	980	1050	790	380	3210	570
850 - 550	750	375	1500	980	1050	790	380	3250	570
900 - 600	750	415	1500	1050	1120	860	380	3200	570
900 - 615	900	420	1800	1050	1120	860	440	3200	660
900 - 620	625	365	1250	1050	1120	860	320	3200	470
1000 - 600	750	415	1500	1150	1220	960	380	3650	570
1000 - 615	900	420	1800	1150	1220	960	440	3650	660
1000 - 620	625	365	1250	1150	1220	960	320	3650	470
1000 - 655	900	515	1800	1150	1220	960	440	3750	660
1300 - 820	1150	545	2300	1460	1520	1260	560	3900	850

Permissible tolerances:

- Tolerances in building construction to DIN 18202, Part 4, Group B
- Welded constructions: B/F to DIN EN ISO 13920
- Tolerances for conical seat (detail Y): ISO 2768-mH

Loss diagram

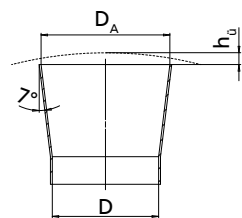

Overflow head
h_u

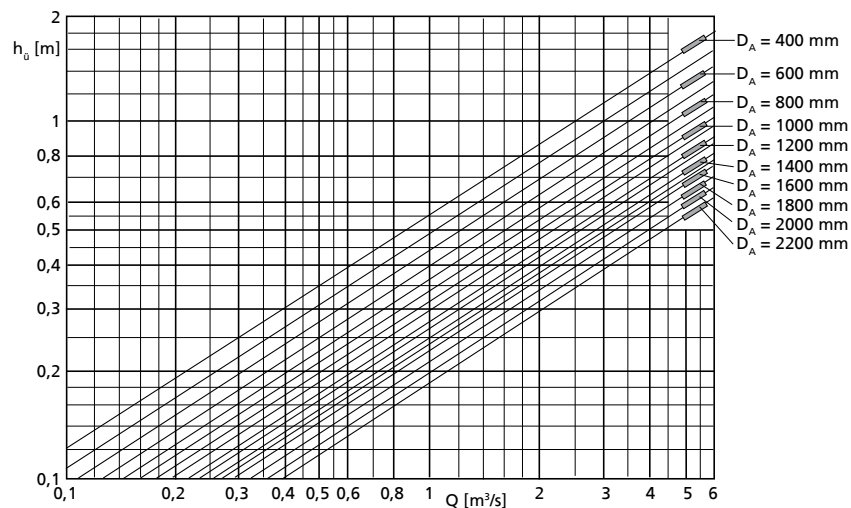

Loss diagram

Calculation formulas:

$$H = H_{geo} + \Delta H_v$$

ΔH_v

- Overflow head h_u (see diagram)
- Loss in the riser (pipe friction)
- Outlet loss $v^2/2 g$ (v refers to D_A)

Overflow head h_u depends on Q and the discharge diameter D_A. The characteristic curve values only apply to unimpeded outlet in all directions; otherwise they are approximate values only.

13) Value for maximum motor length

Minimum water level diagram

Covered chamber

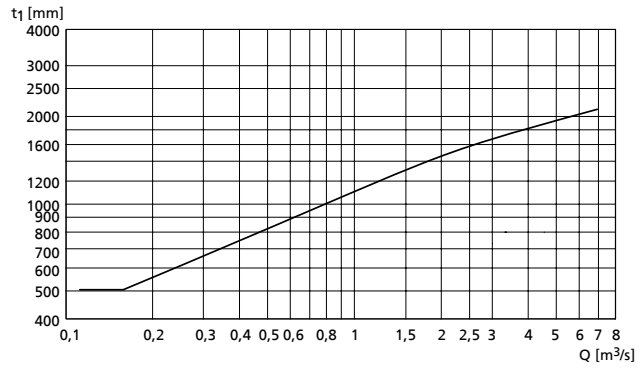

Minimum water level

Installation type CU (Amacan S 650-364 to 800-505)

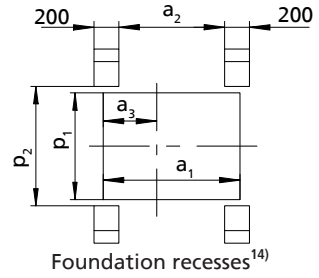
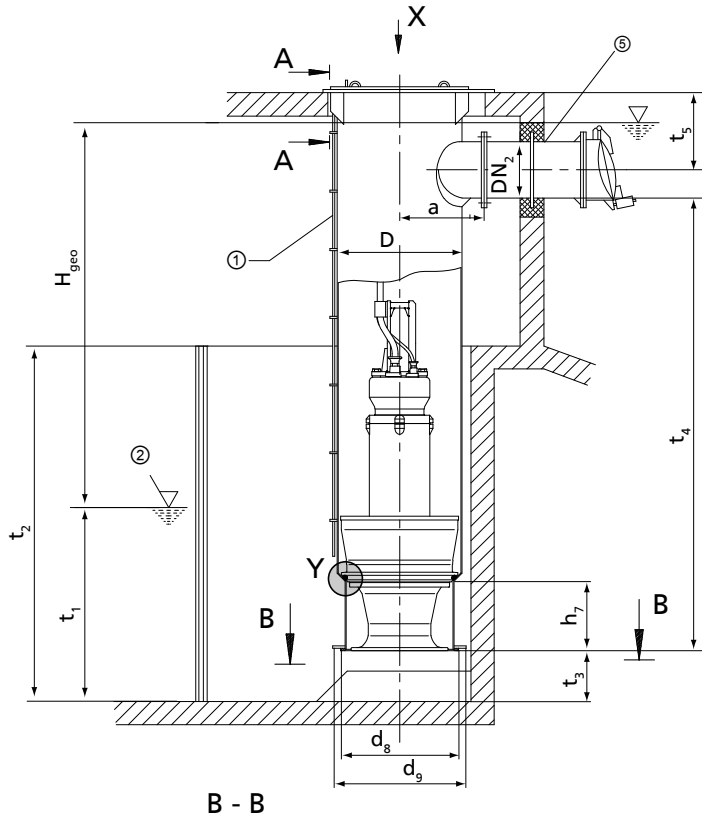

A - A

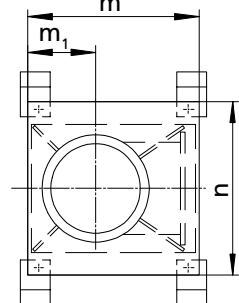
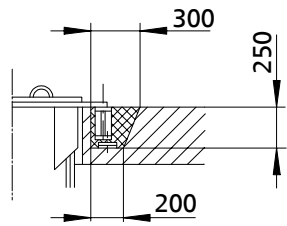

Detail X:
support plate of the discharge tube
Drawing: without pump

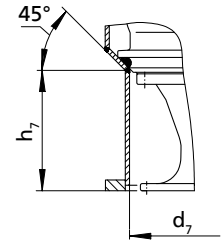
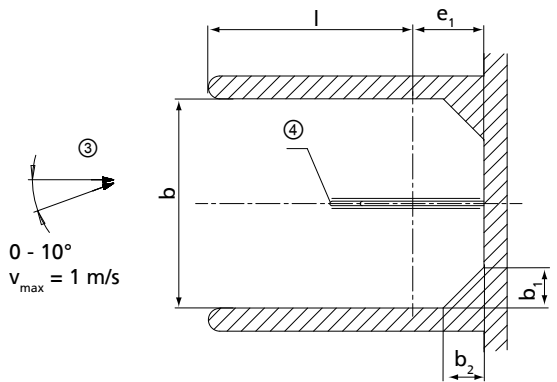

Detail Y:
seating ring

- ①: Vent line,
- ②: Minimum water level (values see diagram on the next page),
- ③: Approach flow,
- ④: Flow-straightening vane (⇒ Page 41)
- ⑤: Connect the discharge pipe to the discharge tube without transmitting any stresses or strains.

14) All dimensions for foundation recesses apply to discharge tube design without intermediate flange.
15) Selected for DN2 max.

Dimensions [mm]

Size	D	DN ₂ min	DN ₂ max	a	a ₁ ¹⁵⁾	a ₂ ¹⁵⁾	a ₃ ¹⁵⁾	b	b ₁		b ₂		d ₇
									with-out suction umbrella d ₈	with suction umbrella d ₉	with-out suction umbrella d ₈	with suction umbrella d ₉	
650 - 364	660	400	600	610	1050	800	405	1000	200	–	200	–	530
650 - 365	660	400	600	610	1050	800	405	1000	200	–	200	–	530
650 - 404	660	400	600	610	1050	800	405	1000	200	–	200	–	530
650 - 405	660	400	600	610	1050	800	405	1250	250	–	250	–	530
800 - 505	813	500	800	700	1220	970	480	1250	250	–	250	–	680

Dimensions [mm]

Size	d ₈	d ₉	e ₁ ¹⁶⁾		h ₇	l _{min}	m ¹⁷⁾	m ₁ ¹⁷⁾	n ¹⁷⁾	p ₁ ¹⁷⁾	p ₂ ¹⁷⁾	t ₃ ¹⁶⁾	t _{4 min} ¹⁸⁾	t ₅ ¹⁷⁾
			with-out suction umbrella d ₈	with suction umbrella d ₉										
650 - 364	660	900	420	540	225	580	1100	430	1160	860	960	260	2350	720
650 - 365	660	900	420	540	225	580	1100	430	1160	860	960	260	2350	720
650 - 404	660	900	420	540	265	580	1100	430	1160	860	960	260	2600	720
650 - 405	660	900	420	540	265	830	1100	430	1160	860	960	320	2750	720
800 - 505	810	1050	500	620	335	750	1270	505	1375	1075	1175	320	2700	835

t₂ = 1.1 x water level; max. 2 x t₁ (depending on head H and structure)
Height of corner lining (b₁ and b₂) equals t₂

Permissible tolerances:

- Tolerances in building construction to DIN 18202, Part 4, Group B
- Welded constructions: B/F to DIN EN ISO 13920
- Tolerances for conical seat (detail Y): ISO 2768-mH
- Discharge flanges to DIN EN 1092-1 PN6, DIN EN 1092-2 PN6

Loss diagram

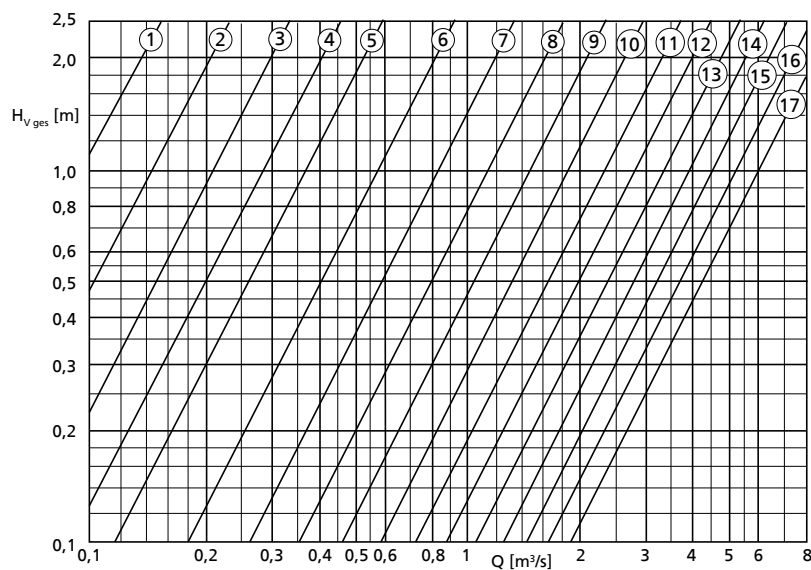

- ① - DN₂ = 200 mm
- ② - DN₂ = 250 mm
- ③ - DN₂ = 300 mm
- ④ - DN₂ = 350 mm
- ⑤ - DN₂ = 400 mm
- ⑥ - DN₂ = 500 mm
- ⑦ - DN₂ = 600 mm
- ⑧ - DN₂ = 700 mm
- ⑨ - DN₂ = 800 mm
- ⑩ - DN₂ = 900 mm
- ⑪ - DN₂ = 1000 mm
- ⑫ - DN₂ = 1100 mm
- ⑬ - DN₂ = 1200 mm
- ⑭ - DN₂ = 1300 mm
- ⑮ - DN₂ = 1400 mm
- ⑯ - DN₂ = 1500 mm
- ⑰ - DN₂ = 1600 mm

Calculation formulas:

$$H = H_{\text{geo}} + \Delta H_v$$

ΔH_v

- Loss in the riser (pipe friction)
- H_{v ges.} (see diagram)

16) Always observe these dimensions.
17) Selected for DN₂ max.
18) Value for maximum motor length

$H_{V ges.}$ comprises:

- Elbow
- Discharge pipe length = $5 \times DN_2$
- Swing check valve
- Outlet losses $v^2/2g$

- ① - $DN_2 = 200$ mm
- ② - $DN_2 = 250$ mm
- ③ - $DN_2 = 300$ mm
- ④ - $DN_2 = 350$ mm
- ⑤ - $DN_2 = 400$ mm
- ⑥ - $DN_2 = 500$ mm
- ⑦ - $DN_2 = 600$ mm
- ⑧ - $DN_2 = 700$ mm
- ⑨ - $DN_2 = 800$ mm
- ⑩ - $DN_2 = 900$ mm
- ⑪ - $DN_2 = 1000$ mm
- ⑫ - $DN_2 = 1100$ mm
- ⑬ - $DN_2 = 1200$ mm
- ⑭ - $DN_2 = 1300$ mm
- ⑮ - $DN_2 = 1400$ mm
- ⑯ - $DN_2 = 1500$ mm
- ⑰ - $DN_2 = 1600$ mm

Minimum water level diagram

Open chamber

t_1 [mm]

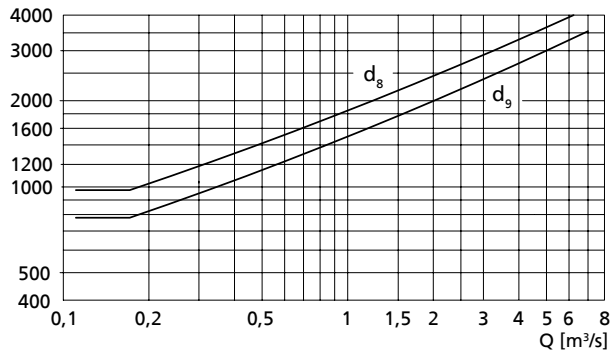

Minimum water level

d_8 = Design: **without** suction umbrella (standard)

d_9 = Design: **with** suction umbrella

Installation type CU (Amacan S 800-535 to 1300-820)

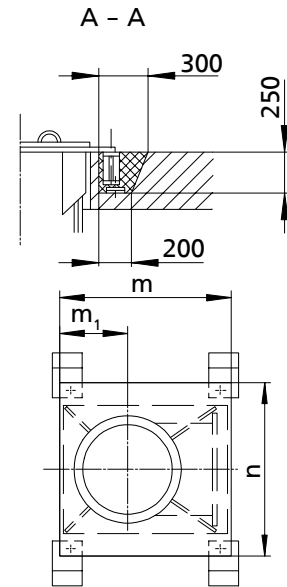
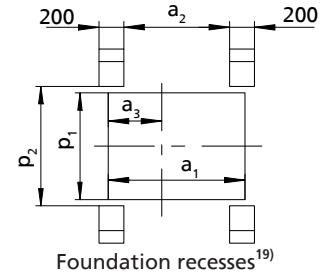
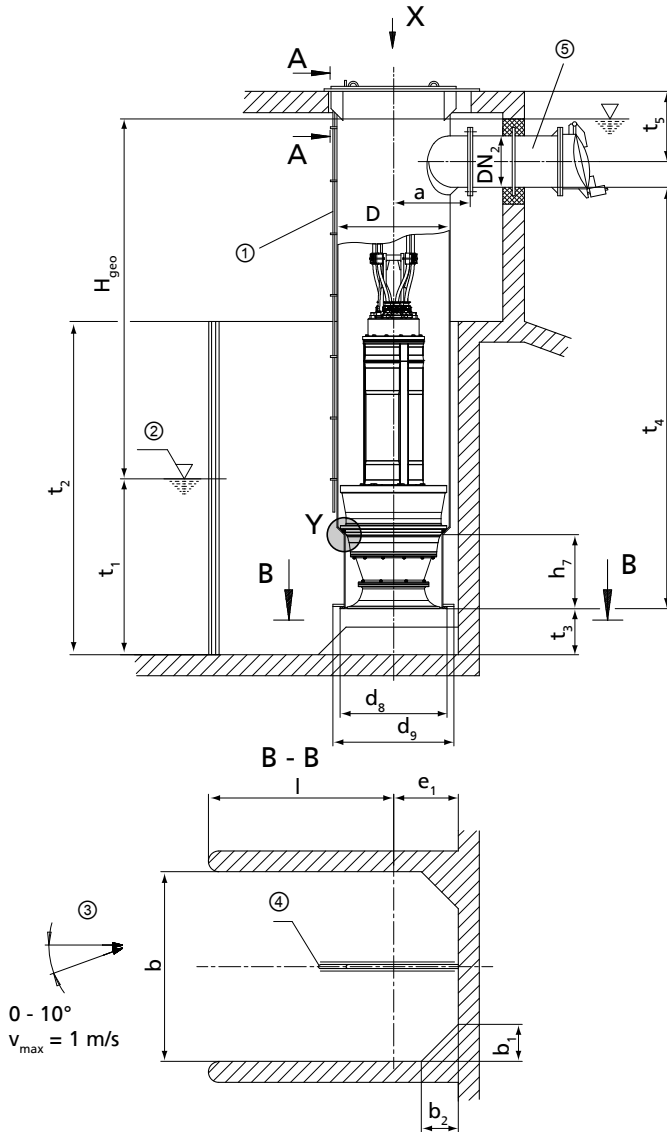

Detail X:
support plate of the discharge tube
Drawing: without pump

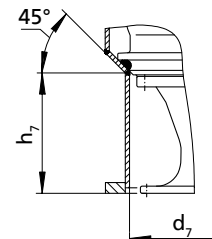

Detail Y:
seating ring

③
0 - 10°
v_{max} = 1 m/s

- ①: Vent line
- ②: Minimum fluid level (values see diagram on the next page)
- ③: Approach flow
- ④: Flow-straightening vane (⇒ Page 41)
- ⑤: Connect the discharge pipe to the discharge tube without transmitting any stresses or strains.

Dimensions [mm]

Size	D	DN ₂ min	DN ₂ max	a	a ₁	a ₂	a ₃	b	b ₁		b ₂		d ₇
									with-out suction umbrella d ₈	with suction umbrella d ₉	with-out suction umbrella d ₈	with suction umbrella d ₉	
800 - 535	813	500	800	700	1220	970	480	1500	300	-	300	-	720
850 - 535	868	500	800	730	1275	1020	505	1500	300	-	300	-	720
850 - 550	868	500	800	730	1275	1020	505	1500	300	-	300	-	740
900 - 600	914	600	900	760	1320	1070	530	1500	300	-	300	-	800
900 - 615	914	600	900	760	1320	1070	530	1800	360	-	360	-	780
900 - 620	914	600	900	760	1320	1070	530	1250	250	-	250	-	770

19) All dimensions for foundation recesses apply to discharge tube design without intermediate flange.

Size	D	DN ₂ min	DN ₂ max	a	a ₁	a ₂	a ₃	b	b ₁		b ₂		d ₇
									with-out suction umbrella d ₈	with suction umbrella d ₉	with-out suction umbrella d ₈	with suction umbrella d ₉	
1000 - 600	1016	700	1000	810	1430	1160	580	1500	300	-	300	-	800
1000 - 615	1016	700	1000	810	1430	1160	580	1800	360	-	360	-	780
1000 - 620	1016	700	1000	810	1430	1160	580	1250	250	-	250	-	770
1000 - 655	1016	700	1000	810	1430	1160	580	1800	360	-	360	-	920
1300 - 820	1320	1000	1300	960	1720	1470	720	2300	460	-	460	-	1080

Dimensions [mm]

Size	d ₈	d ₉	e ²⁰⁾		h ₇	l _{min}	m	m ₁	n	p ₁	p ₂	t ₃ ²⁰⁾	t _{4 min} ²¹⁾	t ₅ ²²⁾
			with-out suction umbrella d ₈	with suction umbrella d ₉										
800 - 535	810	1300	500	750	325	1000	1270	505	1375	1075	1175	380	2800	835
850 - 535	865	1300	525	750	325	975	1325	530	1375	1075	1175	380	3250	835
850 - 550	865	1300	525	750	375	975	1325	530	1375	1075	1175	380	3250	835
900 - 600	910	1300	550	750	415	950	1380	560	1480	1180	1280	380	3200	925
900 - 615	910	1300	550	750	420	1250	1380	560	1480	1180	1280	440	3200	925
900 - 620	910	1050	550	620	365	700	1380	560	1480	1180	1280	320	3200	925
1000 - 600	1015	1300	600	750	415	900	1520	625	1620	1280	1380	380	3650	980
1000 - 615	1015	1300	600	750	420	1200	1520	625	1620	1280	1380	440	3650	980
1000 - 620	1015	1050	600	620	365	650	1520	625	1620	1280	1380	320	3650	980
1000 - 655	1015	1500	600	850	515	1200	1520	625	1620	1280	1380	440	3750	980
1300 - 820	1320	1800	750	1000	545	1550	1810	765	1960	1620	1720	560	3900	1180

t₂ = 1.1 x water level; max. 2 x t₁ (depending on head H and structure)
Height of corner lining (b₁ and b₂) equals t₂

Permissible tolerances:

- Tolerances in building construction to DIN 18202, Part 4, Group B
- Welded constructions: B/F to DIN EN ISO 13920
- Tolerances for conical seat (detail Y): ISO 2768-mH
- Discharge flanges to DIN EN 1092-1 PN6, DIN EN 1092-2 PN6

Loss diagram

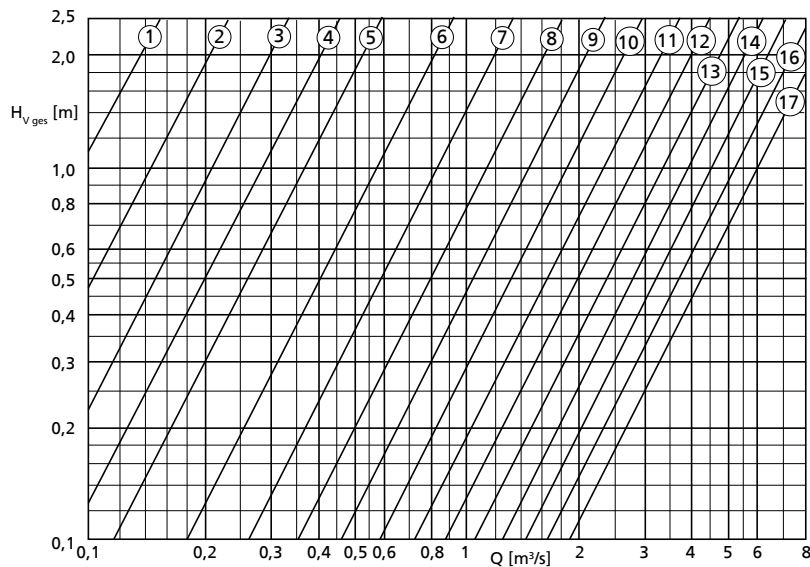

- ① - DN₂ = 200 mm
- ② - DN₂ = 250 mm
- ③ - DN₂ = 300 mm
- ④ - DN₂ = 350 mm
- ⑤ - DN₂ = 400 mm
- ⑥ - DN₂ = 500 mm
- ⑦ - DN₂ = 600 mm
- ⑧ - DN₂ = 700 mm
- ⑨ - DN₂ = 800 mm
- ⑩ - DN₂ = 900 mm
- ⑪ - DN₂ = 1000 mm
- ⑫ - DN₂ = 1100 mm
- ⑬ - DN₂ = 1200 mm
- ⑭ - DN₂ = 1300 mm
- ⑮ - DN₂ = 1400 mm
- ⑯ - DN₂ = 1500 mm
- ⑰ - DN₂ = 1600 mm

Calculation formulas:

$$H = H_{\text{geo}} + \Delta H_v$$

$$\Delta H_v$$

- Loss in the riser (pipe friction)
- H_{v ges.} (see diagram)

20) Always observe these dimensions.
21) Value for maximum motor length
22) Selected for DN2 max.

$H_{V ges.}$ comprises:

- Elbow
- Discharge pipe length = $5 \times DN_2$
- Swing check valve
- Outlet losses $v^2/2g$

- ① - $DN_2 = 200$ mm
- ② - $DN_2 = 250$ mm
- ③ - $DN_2 = 300$ mm
- ④ - $DN_2 = 350$ mm
- ⑤ - $DN_2 = 400$ mm
- ⑥ - $DN_2 = 500$ mm
- ⑦ - $DN_2 = 600$ mm
- ⑧ - $DN_2 = 700$ mm
- ⑨ - $DN_2 = 800$ mm
- ⑩ - $DN_2 = 900$ mm
- ⑪ - $DN_2 = 1000$ mm
- ⑫ - $DN_2 = 1100$ mm
- ⑬ - $DN_2 = 1200$ mm
- ⑭ - $DN_2 = 1300$ mm
- ⑮ - $DN_2 = 1400$ mm
- ⑯ - $DN_2 = 1500$ mm
- ⑰ - $DN_2 = 1600$ mm

Minimum water level diagram

Open chamber

t_1 [mm]

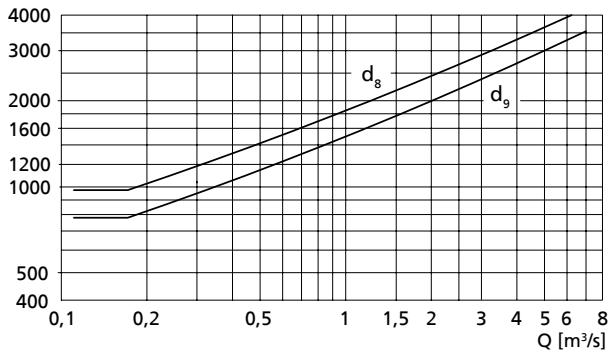

Minimum water level

d_8 = Design: **without** suction umbrella (standard)

d_9 = Design: **with** suction umbrella

Installation type CG (Amacan S 650-364 to 800-505)

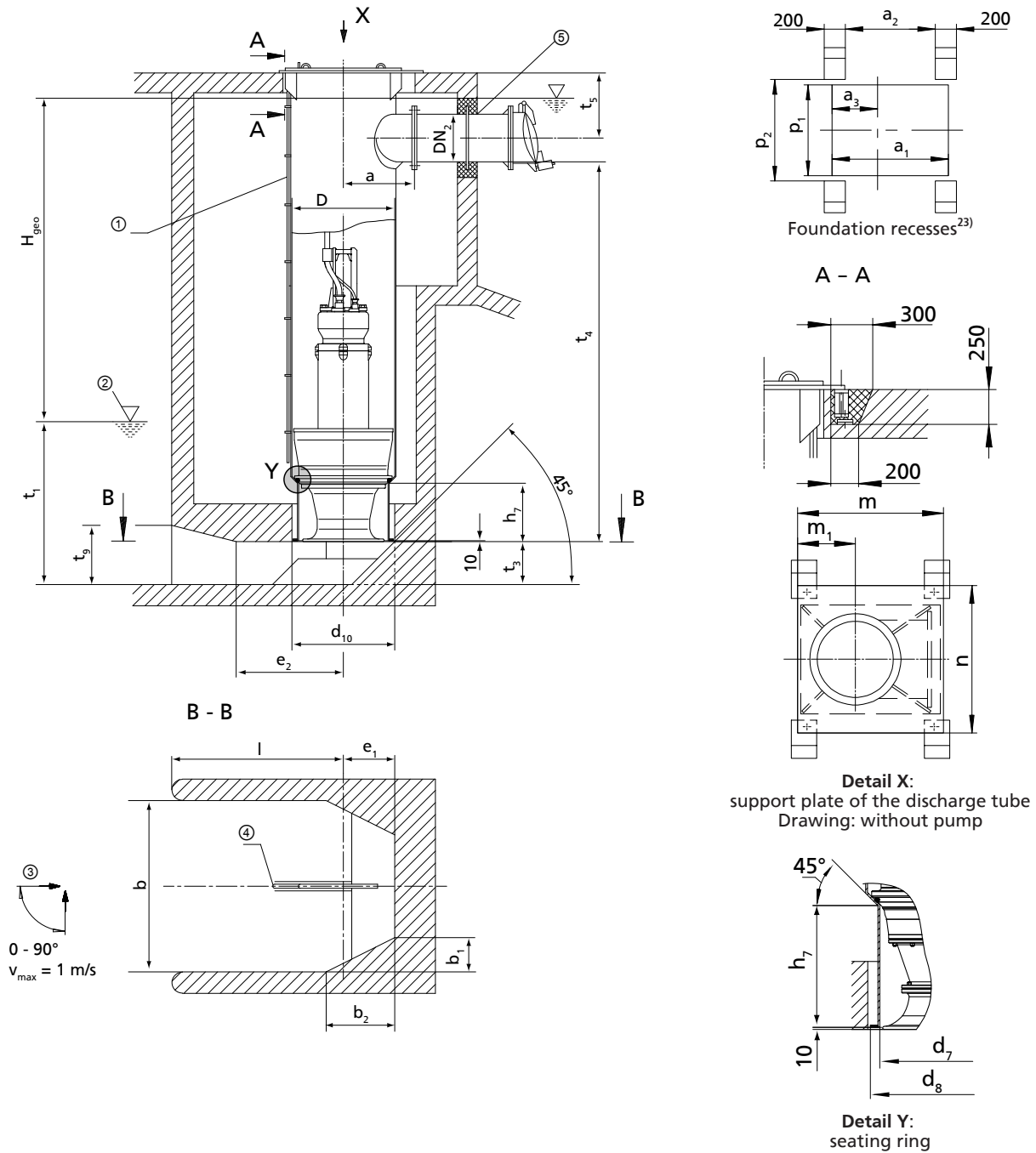

23) All dimensions for foundation recesses apply to discharge tube design without intermediate flange.
 24) Selected for DN2 max.

Dimensions [mm]

Size	D	DN ₂ min	DN ₂ max	a	a ₁ ²⁴⁾	a ₂ ²⁴⁾	a ₃ ²⁴⁾	b	b ₁	b ₂	d ₇	d ₈	d ₁₀
650 - 364	660	400	600	610	1050	800	405	1000	200	400	530	550	600
650 - 365	660	400	600	610	1050	800	405	1000	200	400	530	550	600
650 - 404	660	400	600	610	1050	800	405	1000	200	400	530	550	600
650 - 405	660	400	600	610	1050	800	405	1250	250	500	530	660	690
800 - 505	813	500	800	700	1220	970	480	1250	250	500	680	700	735

Dimensions [mm]

Size	e ₁ ²⁵⁾	e ₂	h ₇	l _{min}	m ²⁴⁾	m ₁ ²⁴⁾	n ²⁴⁾	p ₁ ²⁴⁾	p ₂ ²⁴⁾	t ₃ ²⁵⁾	t _{4 min} ²⁶⁾	t _{5 min} ²⁴⁾	t ₉
650 - 364	300	500	225	1000	1100	430	1160	860	960	260	2350	720	375
650 - 365	300	500	225	1000	1100	430	1160	860	960	260	2350	720	375
650 - 404	300	500	265	1000	1100	430	1160	860	960	260	2600	720	375
650 - 405	375	625	265	1250	1100	430	1160	860	960	320	2750	720	470
800 - 505	375	625	335	1250	1270	505	1375	1075	1175	320	2700	835	470

Permissible tolerances:

- Tolerances in building construction to DIN 18202, Part 4, Group B
- Welded constructions: B/F to DIN EN ISO 13920
- Tolerances for conical seat (detail Y): ISO 2768-mH
- Discharge flanges to DIN EN 1092-1 PN6, DIN EN 1092-2 PN6

Loss diagram

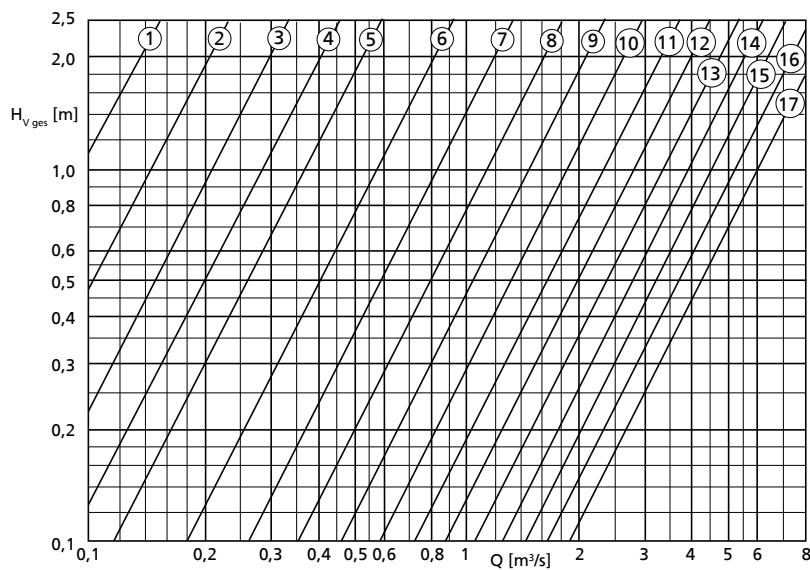

- ① - DN₂ = 200 mm
- ② - DN₂ = 250 mm
- ③ - DN₂ = 300 mm
- ④ - DN₂ = 350 mm
- ⑤ - DN₂ = 400 mm
- ⑥ - DN₂ = 500 mm
- ⑦ - DN₂ = 600 mm
- ⑧ - DN₂ = 700 mm
- ⑨ - DN₂ = 800 mm
- ⑩ - DN₂ = 900 mm
- ⑪ - DN₂ = 1000 mm
- ⑫ - DN₂ = 1100 mm
- ⑬ - DN₂ = 1200 mm
- ⑭ - DN₂ = 1300 mm
- ⑮ - DN₂ = 1400 mm
- ⑯ - DN₂ = 1500 mm
- ⑰ - DN₂ = 1600 mm

Calculation formulas:

$$H = H_{\text{geo}} + \Delta H_v$$

$$\Delta H_v$$

- Loss in the riser (pipe friction)
- H_{v ges.} (see diagram)

H_{v ges.} comprises:

- Elbow
- Discharge pipe length = 5 x DN₂
- Swing check valve
- Outlet losses v²/2g

25) Always observe this dimension.

26) Value for maximum motor length

Minimum water level diagram

Covered chamber

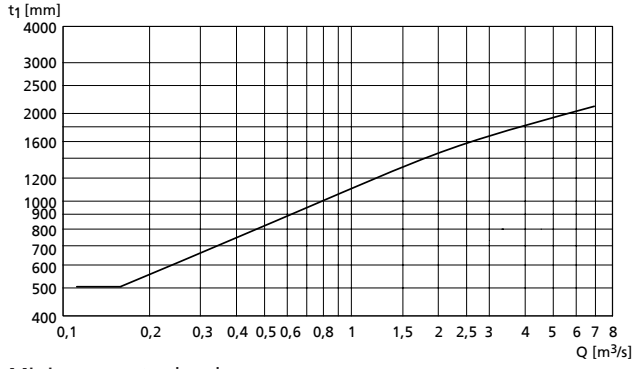

Minimum water level

Installation type CG (Amacan S 800-535 to 1300-820)

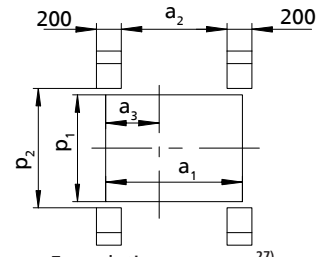
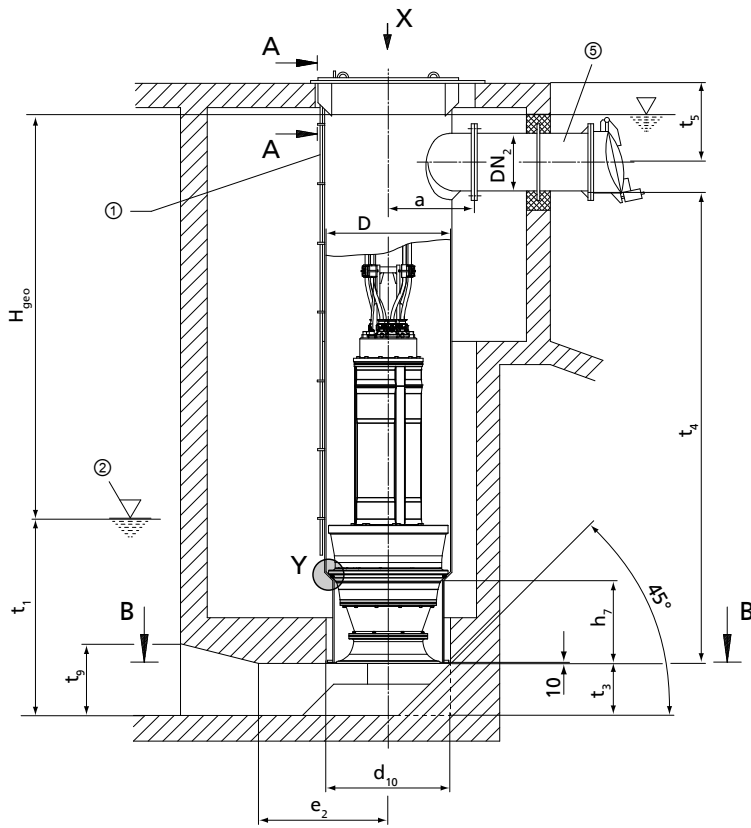

Foundation recesses ²⁷⁾

A - A

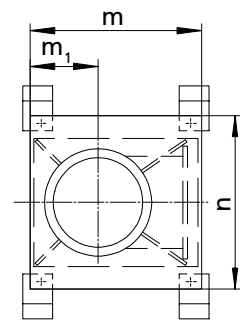
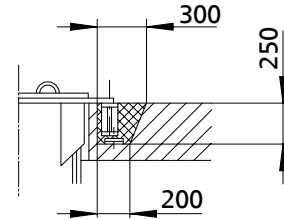

Detail X:

support plate of the discharge tube
Drawing: without pump

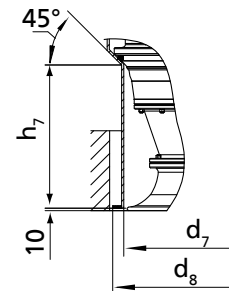

Detail Y:
seating ring

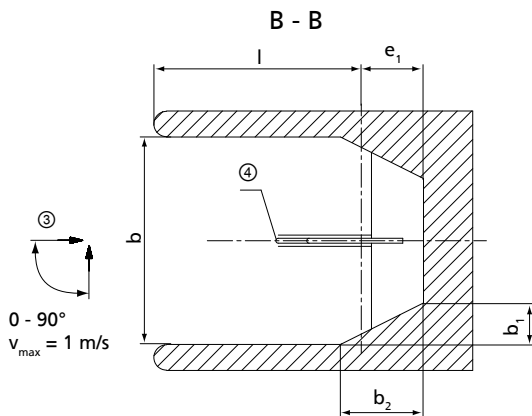

- ①: Vent line
- ②: Minimum fluid level (values see diagram on the next page)
- ③: Approach flow
- ④: Flow-straightening vane (⇒ Page 41)
- ⑤: Connect the discharge pipe to the discharge tube without transmitting any stresses or strains.

Dimensions [mm]

Size	D	DN ₂ min	DN ₂ max	a	a ₁	a ₂	a ₃	b	b ₁	b ₂	d ₇	d ₈	d ₁₀
800 - 535	813	500	800	700	1220	970	480	1500	300	600	720	840	885
850 - 535	868	500	800	730	1275	1020	505	1500	300	600	720	840	885
850 - 550	868	500	800	730	1275	1020	505	1500	300	600	740	840	885
900 - 600	914	600	900	760	1320	1070	530	1500	300	600	800	820	860
900 - 615	914	600	900	760	1320	1070	530	1800	360	720	780	910	955

27) All dimensions for foundation recesses apply to discharge tube design without intermediate flange.

Size	D	DN ₂ min	DN ₂ max	a	a ₁	a ₂	a ₃	b	b ₁	b ₂	d ₇	d ₈	d ₁₀
900 - 620	914	600	900	760	1320	1070	530	1250	250	500	770	790	830
1000 - 600	1016	700	1000	810	1430	1160	580	1500	300	600	800	820	860
1000 - 615	1016	700	1000	810	1430	1160	580	1800	360	720	780	1000	1040
1000 - 620	1016	700	1000	810	1430	1160	580	1250	250	500	770	790	830
1000 - 655	1016	700	1000	810	1430	1160	580	1800	360	720	920	1000	1040
1300 - 820	1320	1000	1300	960	1720	1470	720	2300	460	920	1080	1300	1360

Dimensions [mm]

Size	e ₁ ²⁸⁾	e ₂	h ₇	l _{min}	m	m ₁	n	p ₁	p ₂	t ₃ ²⁸⁾	t ₄ min ₂₉₎	t ₅ min ₃₀₎	t ₉
800 - 535	450	750	325	1500	1270	505	1375	1075	1175	380	2800	835	570
850 - 535	450	750	325	1500	1325	530	1375	1075	1175	380	3250	835	570
850 - 550	450	750	375	1500	1325	530	1375	1075	1175	380	3250	835	570
900 - 600	450	750	415	1500	1380	560	1480	1180	1280	380	3200	925	570
900 - 615	520	900	420	1800	1380	560	1480	1180	1280	440	3200	925	660
900 - 620	415	625	365	1250	1380	560	1480	1180	1280	320	3200	925	470
1000 - 600	450	750	415	1500	1520	625	1620	1280	1380	380	3650	980	570
1000 - 615	520	900	420	1800	1520	625	1620	1280	1380	440	3650	980	660
1000 - 620	415	625	365	1250	1520	625	1620	1280	1380	320	3650	980	470
1000 - 655	520	900	515	1800	1520	625	1620	1280	1380	440	3750	980	660
1300 - 820	680	1150	545	2300	1810	765	1960	1620	1720	560	3900	1180	850

Permissible tolerances:

- Tolerances in building construction to DIN 18202, Part 4, Group B
- Welded constructions: B/F to DIN EN ISO 13920
- Tolerances for conical seat (detail Y): ISO 2768-mH
- Discharge flanges to DIN EN 1092-1 PN6, DIN EN 1092-2 PN6

Loss diagram

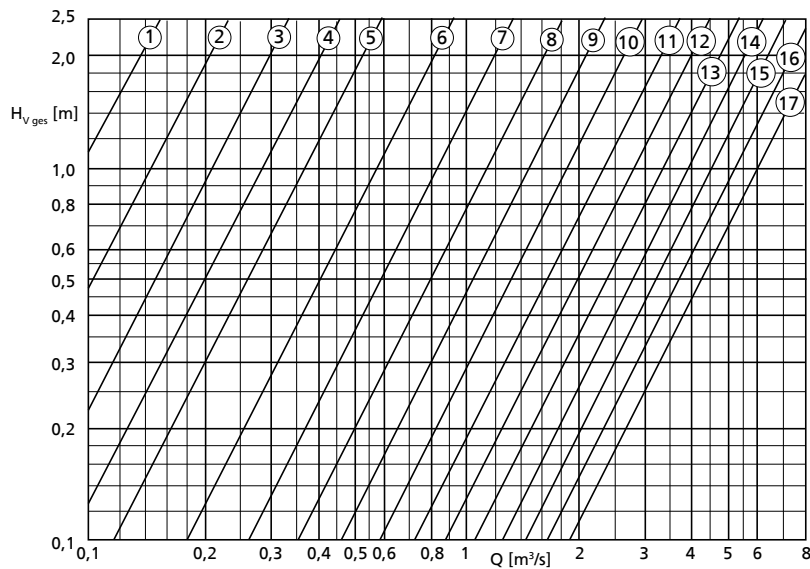

- ① - DN₂ = 200 mm
- ② - DN₂ = 250 mm
- ③ - DN₂ = 300 mm
- ④ - DN₂ = 350 mm
- ⑤ - DN₂ = 400 mm
- ⑥ - DN₂ = 500 mm
- ⑦ - DN₂ = 600 mm
- ⑧ - DN₂ = 700 mm
- ⑨ - DN₂ = 800 mm
- ⑩ - DN₂ = 900 mm
- ⑪ - DN₂ = 1000 mm
- ⑫ - DN₂ = 1100 mm
- ⑬ - DN₂ = 1200 mm
- ⑭ - DN₂ = 1300 mm
- ⑮ - DN₂ = 1400 mm
- ⑯ - DN₂ = 1500 mm
- ⑰ - DN₂ = 1600 mm

Calculation formulas:

$$H = H_{\text{geo}} + \Delta H_v$$

ΔH_v

- Loss in the riser (pipe friction)
- $H_{v \text{ ges.}}$ (see diagram)

28) Always observe this dimension.
29) Value for maximum motor length
30) Selected for DN2 max.

$H_{v\text{ ges.}}$ comprises:

- Elbow
- Discharge pipe length = $5 \times DN_2$
- Swing check valve
- Outlet losses $v^2/2g$

- ① - $DN_2 = 200$ mm
- ② - $DN_2 = 250$ mm
- ③ - $DN_2 = 300$ mm
- ④ - $DN_2 = 350$ mm
- ⑤ - $DN_2 = 400$ mm
- ⑥ - $DN_2 = 500$ mm
- ⑦ - $DN_2 = 600$ mm
- ⑧ - $DN_2 = 700$ mm
- ⑨ - $DN_2 = 800$ mm
- ⑩ - $DN_2 = 900$ mm
- ⑪ - $DN_2 = 1000$ mm
- ⑫ - $DN_2 = 1100$ mm
- ⑬ - $DN_2 = 1200$ mm
- ⑭ - $DN_2 = 1300$ mm
- ⑮ - $DN_2 = 1400$ mm
- ⑯ - $DN_2 = 1500$ mm
- ⑰ - $DN_2 = 1600$ mm

Minimum water level diagram

Covered chamber

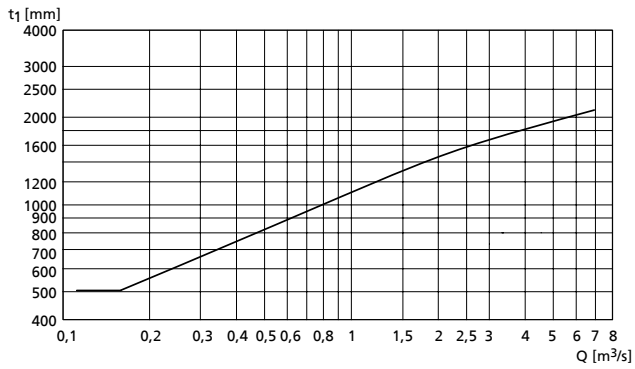

Minimum water level

Installation type DU (Amacan S 650-364 to 800-505)

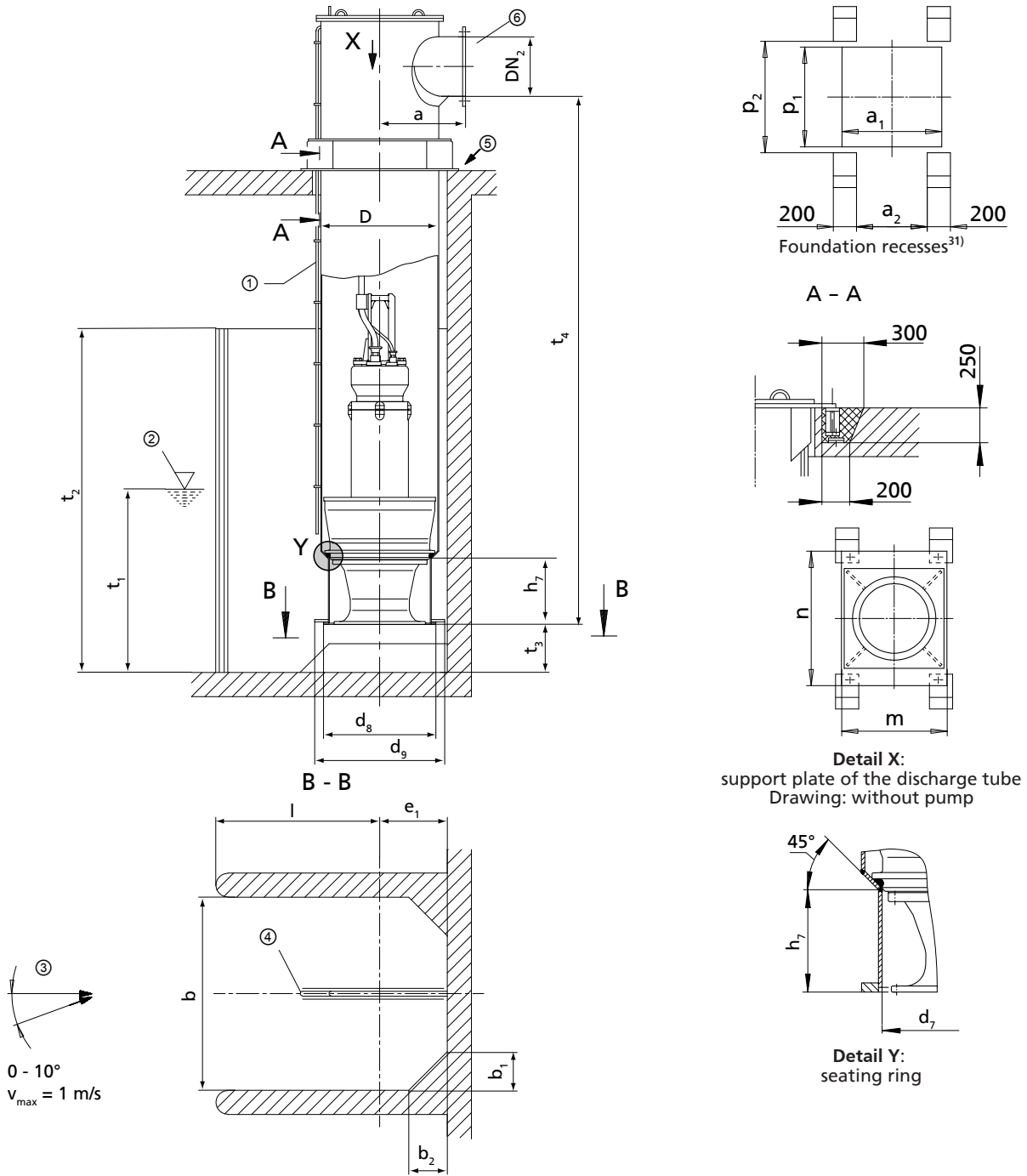

- ①: Vent line,
- ②: Minimum water level (values see diagram on the next page),
- ③: Approach flow,
- ④: Flow-straightening vane (⇒ Page 41) ,
- ⑤: Not pressure-proof
- ⑥: Connect the discharge pipe to the discharge tube without transmitting any stresses or strains.

31) All dimensions for foundation recesses apply to discharge tube design without intermediate flange.

Dimensions [mm]

Size	D	DN ₂ min	DN ₂ max	a	a ₁	a ₂	b	b ₁		b ₂		d ₇
								without suction umbrella d ₈	with suction umbrella d ₉	without suction umbrella d ₈	with suction umbrella d ₉	
650 - 364	660	400	600	610	810	560	1000	200	–	200	–	530
650 - 365	660	400	600	610	810	560	1000	200	–	200	–	530
650 - 404	660	400	600	610	810	560	1000	200	–	200	–	530
650 - 405	660	400	600	610	810	560	1250	250	–	250	–	530
800 - 505	813	500	800	700	960	710	1250	250	–	250	–	680

Dimensions [mm]

Size	d ₈	d ₉	e ₁ ³²⁾		h ₇	l _{min}	m	n	p ₁	p ₂	t ₃ ³²⁾	t _{4 min} ³³⁾
			with-out suction umbrella d ₈	with suction umbrella d ₉								
650 - 364	660	900	420	540	225	580	860	1110	810	910	260	2350
650 - 365	660	900	420	540	225	580	860	1110	810	910	260	2350
650 - 404	660	900	420	540	265	580	860	1110	810	910	260	2600
650 - 405	660	900	420	540	265	830	860	1110	810	910	320	2750
800 - 505	810	1050	500	620	335	750	1030	1260	960	1060	320	2700

t₂ = 1.1 x water level; max. 2 x t₁ (depending on head H and structure)
Height of corner lining (b₁ and b₂) equals t₂

Permissible tolerances:

- Tolerances in building construction to DIN 18202, Part 4, Group B
- Welded constructions: B/F to DIN EN ISO 13920
- Tolerances for conical seat (detail Y): ISO 2768-mH
- Discharge flanges to DIN EN 1092-1 PN6, DIN EN 1092-2 PN6

Loss diagram

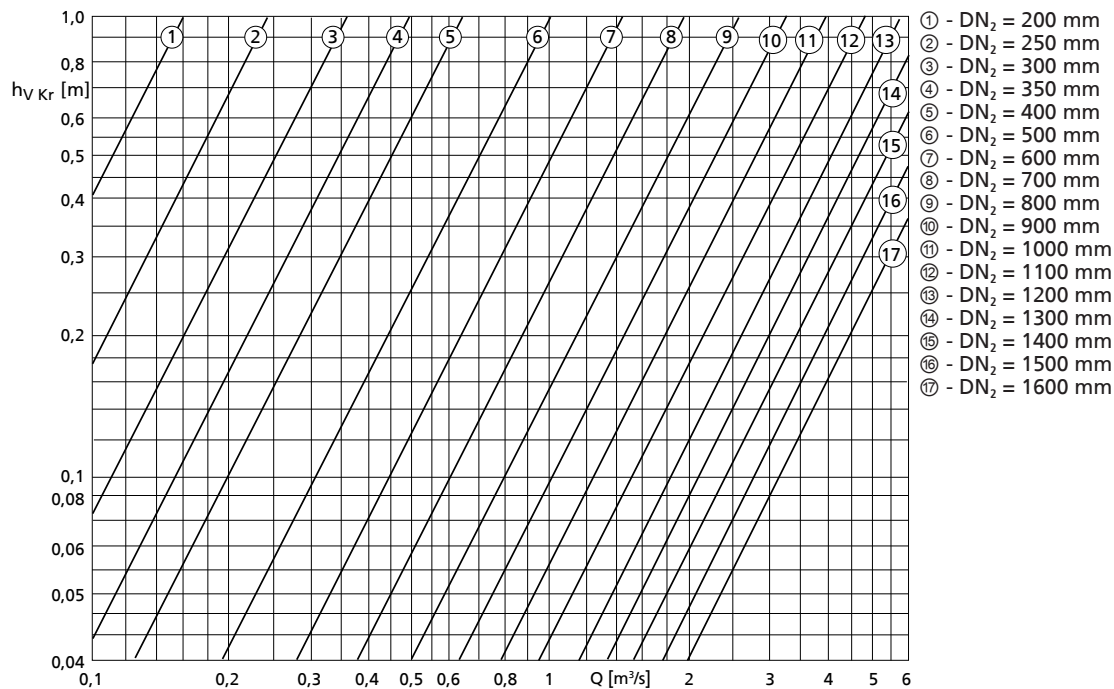

Calculation formulas:

$$H = H_{\text{geo}} + \Delta H_v$$

32) Always observe this dimension.
 33) Value for maximum motor length

ΔH_v

- Loss in the elbow $h_{v,Kr}$ (see diagram)
- Loss in the riser (pipe friction)
- $H_{v,system}$ (valves, etc.)

$H_{v,system}$ must be determined for the specific system.

- ① - DN₂ = 200 mm
- ② - DN₂ = 250 mm
- ③ - DN₂ = 300 mm
- ④ - DN₂ = 350 mm
- ⑤ - DN₂ = 400 mm
- ⑥ - DN₂ = 500 mm
- ⑦ - DN₂ = 600 mm
- ⑧ - DN₂ = 700 mm
- ⑨ - DN₂ = 800 mm
- ⑩ - DN₂ = 900 mm
- ⑪ - DN₂ = 1000 mm
- ⑫ - DN₂ = 1100 mm
- ⑬ - DN₂ = 1200 mm
- ⑭ - DN₂ = 1300 mm
- ⑮ - DN₂ = 1400 mm
- ⑯ - DN₂ = 1500 mm
- ⑰ - DN₂ = 1600 mm

Minimum water level diagram

Open chamber

t_1 [mm]

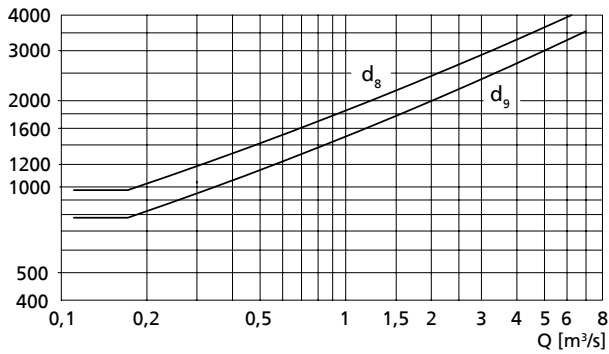

Minimum water level

d_8 = Design: **without** suction umbrella (standard)

d_9 = Design: **with** suction umbrella

Installation type DU (Amacan S 800-535 to 1300-820)

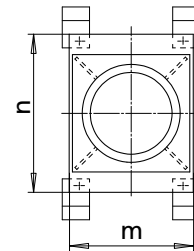
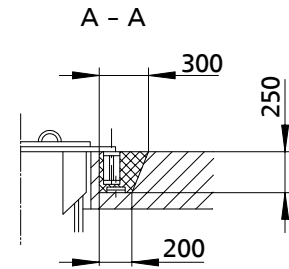
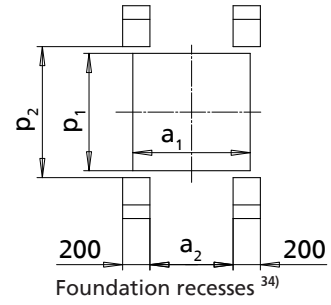
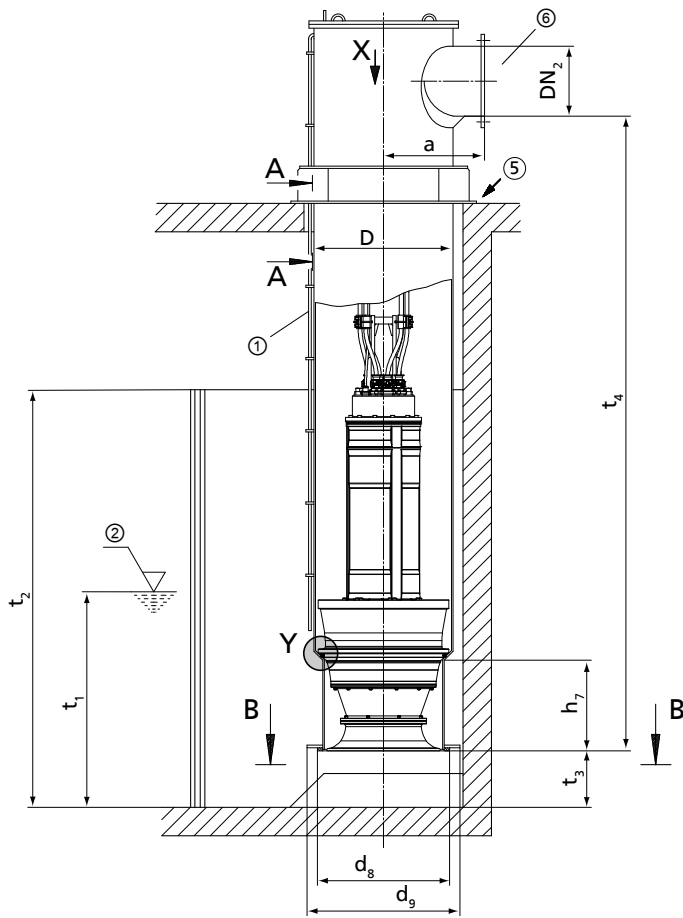

Detail X:
support plate of the discharge tube
Drawing: without pump

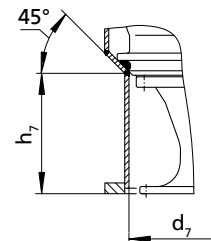

Detail Y:
seating ring

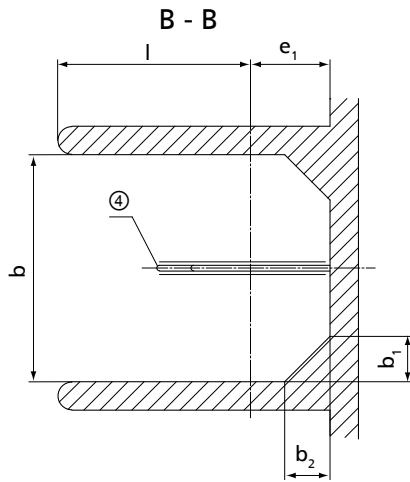
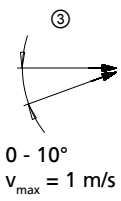

- ①: Vent line
- ②: Minimum fluid level (values see diagram on the next page)
- ③: Approach flow
- ④: Flow-straightening vane (⇒ Page 41)
- ⑤: Not pressure-proof
- ⑥: Connect the discharge pipe to the discharge tube without transmitting any stresses or strains.

34) All dimensions for foundation recesses apply to discharge tube design without intermediate flange.

Dimensions [mm]

Size	D	DN ₂ min	DN ₂ max	a	a ₁	a ₂	b	b ₁		b ₂		d ₇
								without suction umbrella d ₈	with suction umbrella d ₉	without suction umbrella d ₈	with suction umbrella d ₉	
800 - 535	813	500	800	700	960	710	1500	300	-	300	-	720
850 - 535	868	500	800	730	1010	760	1500	300	-	300	-	720
850 - 550	868	500	800	730	1010	760	1500	300	-	300	-	740
900 - 600	914	600	900	760	1060	810	1500	300	-	300	-	800
900 - 615	914	600	900	760	1060	810	1800	360	-	360	-	780
900 - 620	914	600	900	760	1060	810	1250	250	-	250	-	770
1000 - 600	1016	700	1000	810	1160	910	1500	300	-	300	-	800
1000 - 615	1016	700	1000	810	1160	910	1800	360	-	360	-	780
1000 - 620	1016	700	1000	810	1160	910	1250	250	-	250	-	770
1000 - 655	1016	700	1000	810	1160	910	1800	360	-	360	-	920
1300 - 820	1320	1000	1300	960	1460	1210	2300	460	-	460	-	1080

Dimensions [mm]

Size	d ₈	d ₉	e ₁ ³⁵⁾		h ₇	l _{min}	m	n	p ₁	p ₂	t ₃ ³⁵⁾	t ₄ min ³⁶⁾
			with-out suction umbrella d ₈	with suction umbrella d ₉								
800 - 535	810	1300	500	750	325	1000	1030	1260	960	1060	380	2800
850 - 535	865	1300	525	750	325	975	1080	1310	1010	1110	380	3250
850 - 550	865	1300	525	750	375	975	1080	1310	1010	1110	380	3250
900 - 600	910	1300	550	750	415	950	1130	1360	1060	1160	380	3200
900 - 615	910	1300	550	750	420	1250	1130	1360	1060	1160	440	3200
900 - 620	910	1050	550	620	365	700	1130	1360	1060	1160	320	3200
1000 - 600	1015	1300	600	750	415	900	1240	1500	1160	1260	380	3650
1000 - 615	1015	1300	600	750	420	1200	1240	1500	1160	1260	440	3650
1000 - 620	1015	1050	600	620	365	650	1240	1500	1160	1260	320	3650
1000 - 655	1015	1500	600	850	515	1200	1240	1500	1160	1260	440	3750
1300 - 820	1320	1800	750	1000	545	1550	1540	1800	1460	1560	560	3900

t₂ = 1.1 x water level; max. 2 x t₁ (depending on head H and structure)
Height of corner lining (b₁ and b₂) equals t₂

Permissible tolerances:

- Tolerances in building construction to DIN 18202, Part 4, Group B
- Welded constructions: B/F to DIN EN ISO 13920
- Tolerances for conical seat (detail Y): ISO 2768-mH
- Discharge flanges to DIN EN 1092-1 PN6, DIN EN 1092-2 PN6

35) Always observe this dimension.

36) Value for maximum motor length

Loss diagram

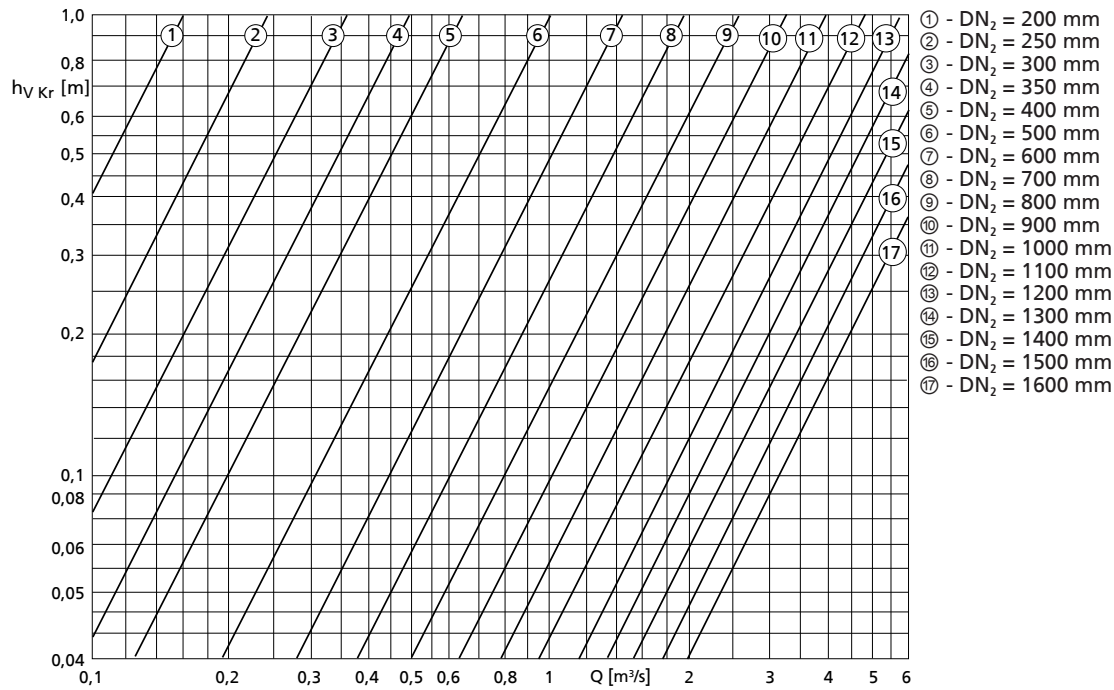

Calculation formulas:

$$H = H_{\text{geo}} + \Delta H_v$$

ΔH_v

- Loss in the elbow $h_{v, Kr}$ (see diagram)
- Loss in the riser (pipe friction)
- $H_{v, \text{system}}$ (valves, etc.)

$H_{v, \text{system}}$ must be determined for the specific system.

Minimum water level diagram

Open chamber

t_i [mm]

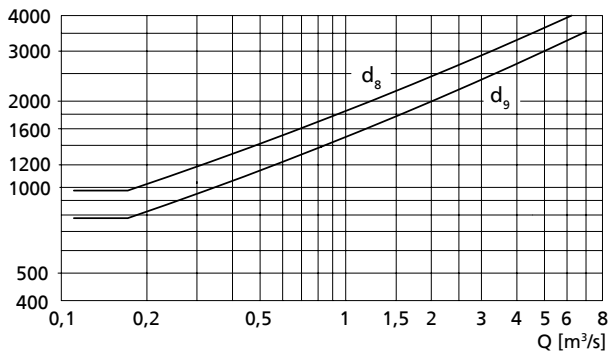

Minimum water level

d_8 = Design: **without** suction umbrella (standard)

d_9 = Design: **with** suction umbrella

Installation type DG (Amacan S 650-364 to 800-505)

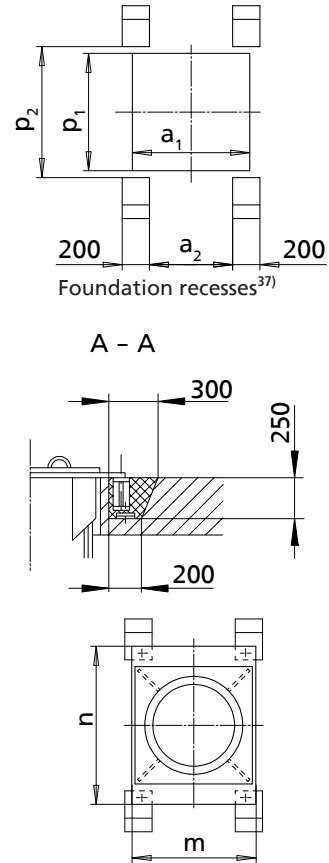
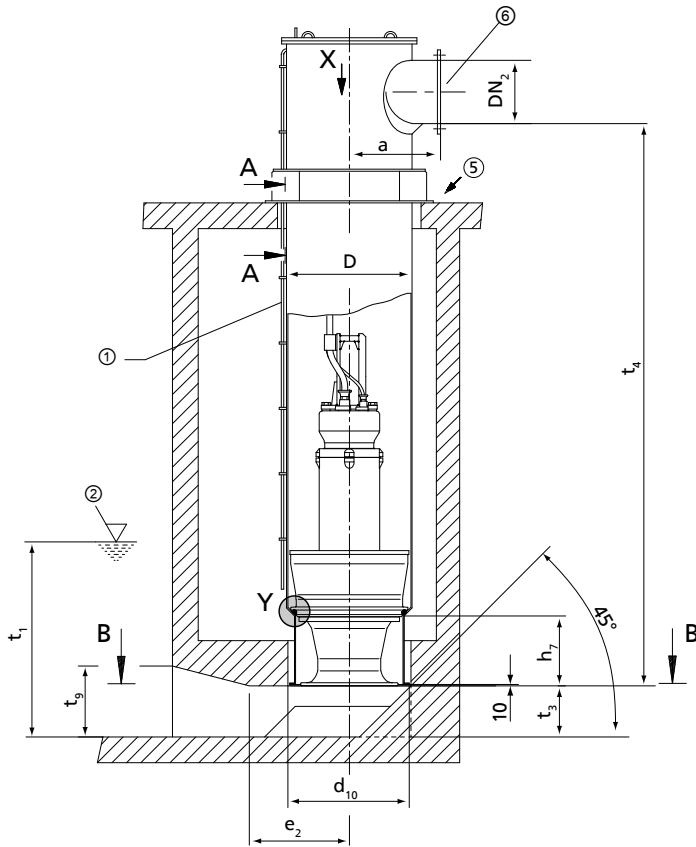

Detail X:
support plate of the discharge tube
Drawing: without pump

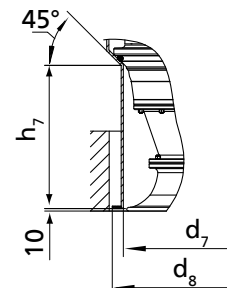

Detail Y:
seating ring

③: Approach flow,
0 - 90°
 $v_{max} = 1 \text{ m/s}$

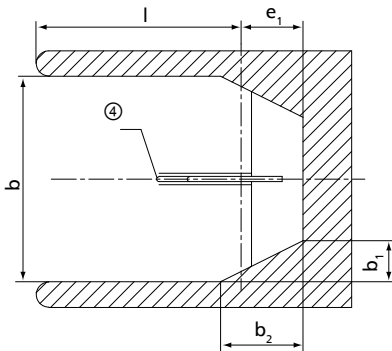

- ①: Vent line,
- ②: Minimum water level (values see diagram on the next page),
- ③: Approach flow,
- ④: Flow-straightening vane (⇒ Page 41) ,
- ⑤: Not pressure-proof
- ⑥: Connect the discharge pipe to the discharge tube without transmitting any stresses or strains.

Dimensions [mm]

Size	D	DN ₂ min	DN ₂ max	a	a ₁	a ₂	b	b ₁	b ₂	d ₇	d ₈	d ₁₀
650 - 364	660	400	600	610	810	560	1000	200	400	530	550	600
650 - 365	660	400	600	610	810	560	1000	200	400	530	550	600
650 - 404	660	400	600	610	810	560	1000	200	400	530	550	600
650 - 405	660	400	600	610	810	560	1250	250	500	530	660	690
800 - 505	813	500	800	700	960	710	1250	250	500	680	700	735

37) All dimensions for foundation recesses apply to discharge tube design without intermediate flange.

Dimensions [mm]

Size	e ₁ ³⁸⁾	e ₂	h ₇	l _{min}	m	n	p ₁	p ₂	t ₃ ³⁸⁾	t _{4 min} ³⁹⁾	t ₉
650 - 364	300	500	225	1000	860	1110	810	910	260	2350	375
650 - 365	300	500	225	1000	860	1110	810	910	260	2350	375
650 - 404	300	500	265	1000	860	1110	810	910	260	2600	375
650 - 405	375	625	265	1250	860	1110	810	910	320	2750	470
800 - 505	375	625	335	1250	1030	1260	960	1060	320	2700	470

Permissible tolerances:

- Tolerances in building construction to DIN 18202, Part 4, Group B
- Welded constructions: B/F to DIN EN ISO 13920
- Tolerances for conical seat (detail Y): ISO 2768-mH
- Discharge flanges to DIN EN 1092-1 PN6, DIN EN 1092-2 PN6

Loss diagram

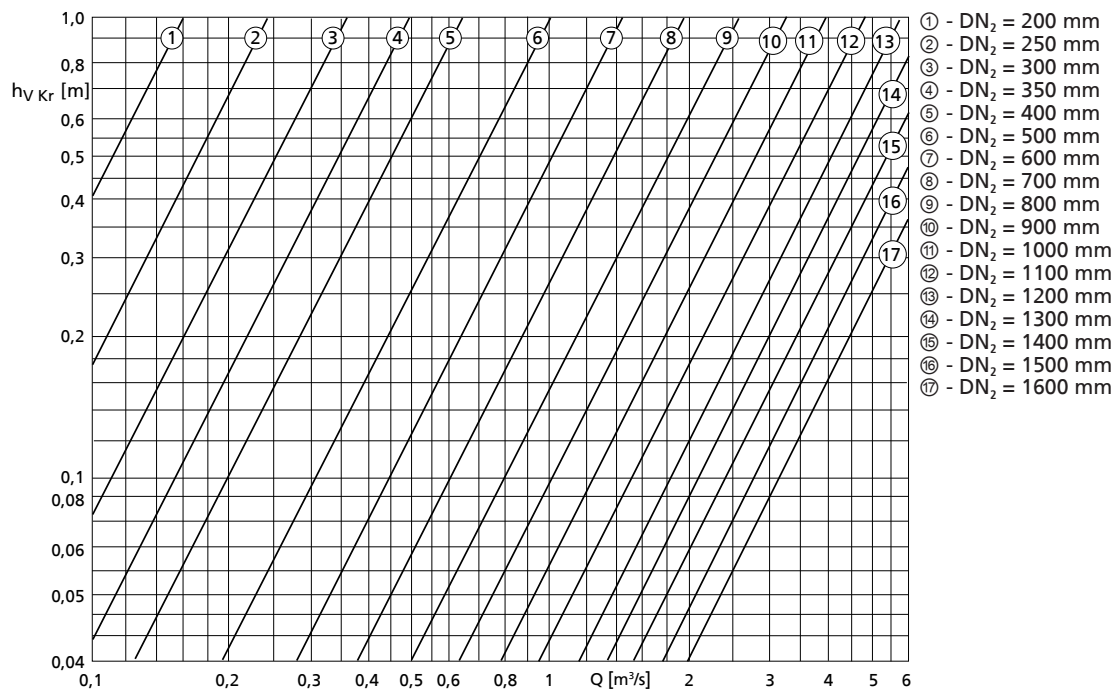

Calculation formulas:

$$H = H_{geo} + \Delta H_v$$

$$\Delta H_v$$

- Loss in the elbow $h_{v Kr}$ (see diagram)
- Loss in the riser (pipe friction)
- $H_{v system}$ (valves, etc.)

$H_{v system}$ must be determined for the specific system.

38) Always observe this dimension.

39) Value for maximum motor length

Minimum water level diagram

Covered chamber

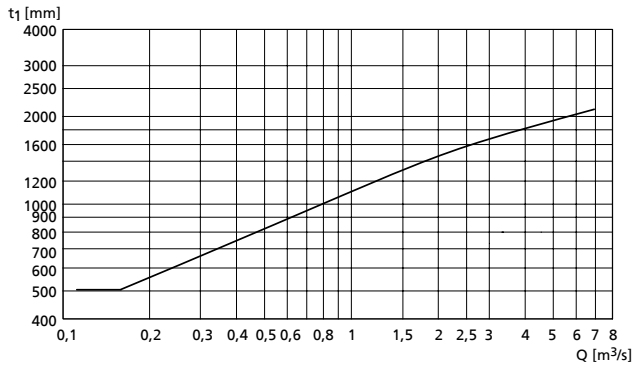

Minimum water level

Installation type DG (Amacan S 800-535 to 1300-820)

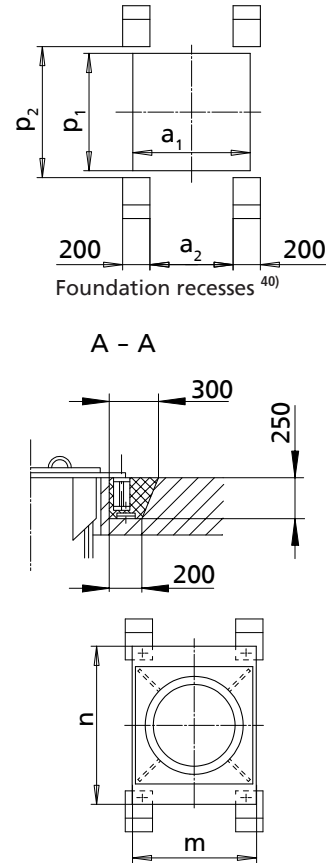
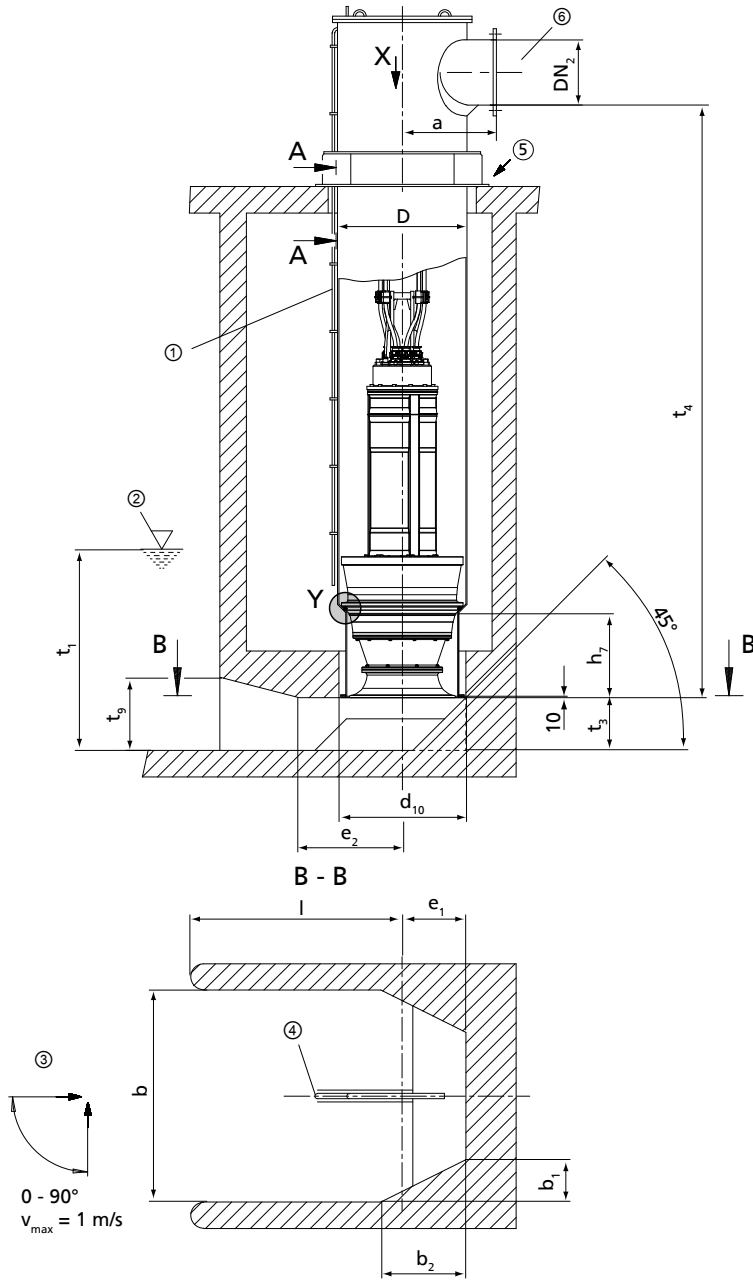

Detail X:
support plate of the discharge tube
Drawing: without pump

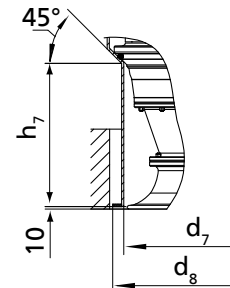

Detail Y:
seating ring

- ①: Vent line
- ②: Minimum fluid level (values see diagram on the next page)
- ③: Approach flow
- ④: Flow-straightening vane (⇒ Page 41)
- ⑤: Not pressure-proof
- ⑥: Connect the discharge pipe to the discharge tube without transmitting any stresses or strains.

Dimensions [mm]

Size	D	DN ₂ min	DN ₂ max	a	a ₁	a ₂	b	b ₁	b ₂	d ₇	d ₈	d ₁₀
800 - 535	813	500	800	700	960	710	1500	300	600	720	840	885
850 - 535	868	500	800	730	1010	760	1500	300	600	720	840	885
850 - 550	868	500	800	730	1010	760	1500	300	600	740	840	885
900 - 600	914	600	900	760	1060	810	1500	300	600	800	820	860
900 - 615	914	600	900	760	1060	810	1800	360	720	780	910	955
900 - 620	914	600	900	760	1060	810	1250	250	500	770	790	830

40) All dimensions for foundation recesses apply to discharge tube design without intermediate flange.

Size	D	DN ₂ min	DN ₂ max	a	a ₁	a ₂	b	b ₁	b ₂	d ₇	d ₈	d ₁₀
1000 - 600	1016	700	1000	810	1160	910	1500	300	600	800	820	860
1000 - 615	1016	700	1000	810	1160	910	1800	360	720	780	1000	1040
1000 - 620	1016	700	1000	810	1160	910	1250	250	500	770	790	830
1000 - 655	1016	700	1000	810	1160	910	1800	360	720	920	1000	1040
1300 - 820	1320	1000	1300	960	1460	1210	2300	460	920	1080	1300	1360

Dimensions [mm]

Size	e ₁ ⁴¹⁾	e ₂	h ₇	l _{min}	m	n	p ₁	p ₂	t ₃ ⁴¹⁾	t ₄ min ⁴²⁾	t ₉
800 - 535	450	750	325	1500	1030	1260	960	1060	380	2800	570
850 - 535	450	750	325	1500	1080	1310	1010	1110	380	3250	570
850 - 550	450	750	375	1500	1080	1310	1010	1110	380	3250	570
900 - 600	450	750	415	1500	1130	1360	1060	1160	380	3200	570
900 - 615	520	900	420	1800	1130	1360	1060	1160	440	3200	660
900 - 620	415	625	365	1250	1130	1360	1060	1160	320	3200	470
1000 - 600	450	750	415	1500	1240	1500	1160	1260	380	3650	570
1000 - 615	520	900	420	1800	1240	1500	1160	1260	440	3650	660
1000 - 620	415	625	365	1250	1240	1500	1160	1260	320	3650	470
1000 - 655	520	900	515	1800	1240	1500	1160	1260	440	3750	660
1300 - 820	680	1150	545	2300	1540	1800	1460	1560	560	3900	850

Permissible tolerances:

- Tolerances in building construction to DIN 18202, Part 4, Group B
- Welded constructions: B/F to DIN EN ISO 13920
- Tolerances for conical seat (detail Y): ISO 2768-mH
- Discharge flanges to DIN EN 1092-1 PN6, DIN EN 1092-2 PN6

Loss diagram

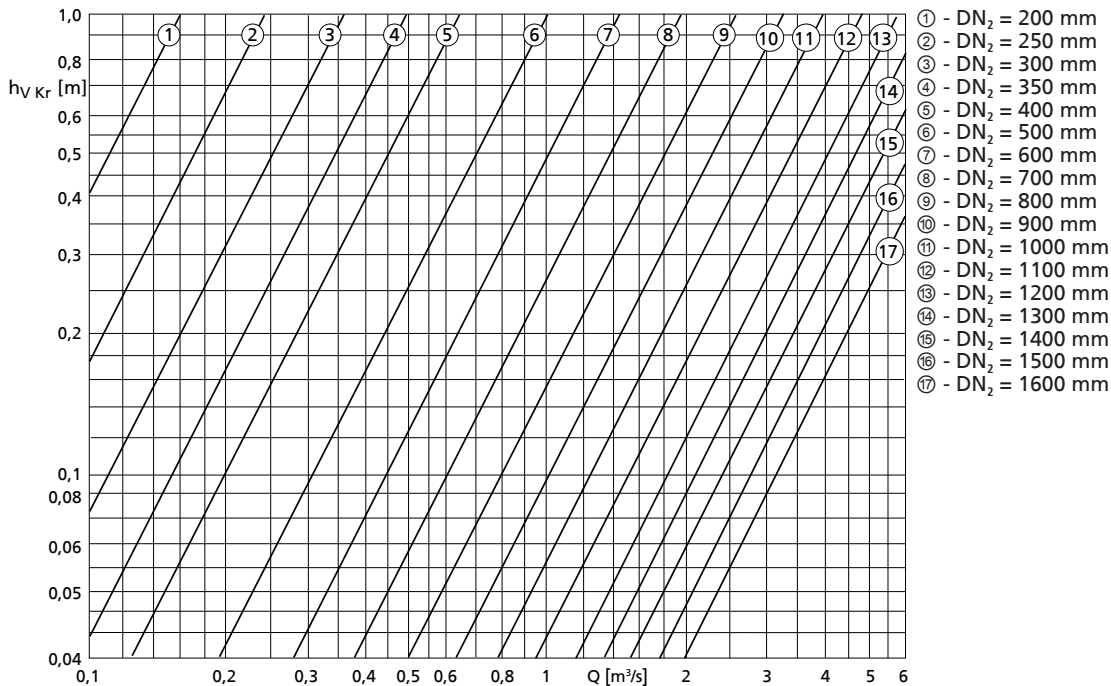

Calculation formulas:

$$H = H_{\text{geo}} + \Delta H_v$$

ΔH_v

- Loss in the elbow $h_{v, Kr}$ (see diagram)
- Loss in the riser (pipe friction)
- $H_{v, \text{System}}$ (valves, etc.)

41) Always observe this dimension.

42) Value for maximum motor length

$H_{V \text{ system}}$ must be determined for the specific system.

- ① - DN₂ = 200 mm
- ② - DN₂ = 250 mm
- ③ - DN₂ = 300 mm
- ④ - DN₂ = 350 mm
- ⑤ - DN₂ = 400 mm
- ⑥ - DN₂ = 500 mm
- ⑦ - DN₂ = 600 mm
- ⑧ - DN₂ = 700 mm
- ⑨ - DN₂ = 800 mm
- ⑩ - DN₂ = 900 mm
- ⑪ - DN₂ = 1000 mm
- ⑫ - DN₂ = 1100 mm
- ⑬ - DN₂ = 1200 mm
- ⑭ - DN₂ = 1300 mm
- ⑮ - DN₂ = 1400 mm
- ⑯ - DN₂ = 1500 mm
- ⑰ - DN₂ = 1600 mm

Minimum water level diagram

Covered chamber

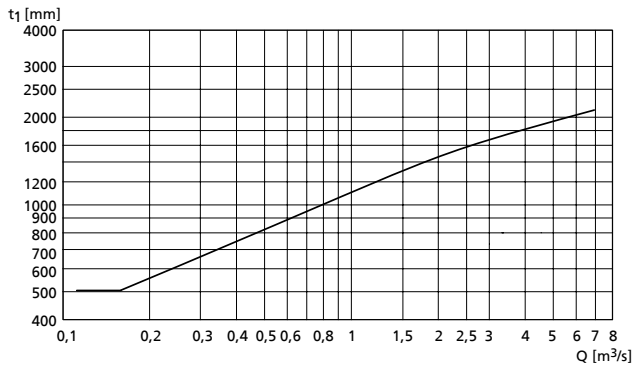

Minimum water level

Dimensions of the flow-straightening vane

Design of the intake chamber wall surfaces (to prevent vortex formation)

The flow-straightening vane is indispensable for ensuring adequate inflow conditions for the pump. It prevents the development of a submerged vortex (floor vortex) which could cause a drop in performance, for example. In addition, the floor and wall surfaces of the intake chamber should be designed as a rough concrete surface. Rough surfaces minimise the separation of boundary layers that may cause wall and floor vortices.

Flow-straightening vane and intake chamber

- The anti-swirl baffles in the bellmouth (part No. 138) must be aligned with the flow-straightening vane.
- The bail is oriented in the same direction as the anti-vortex vanes in the bellmouth.

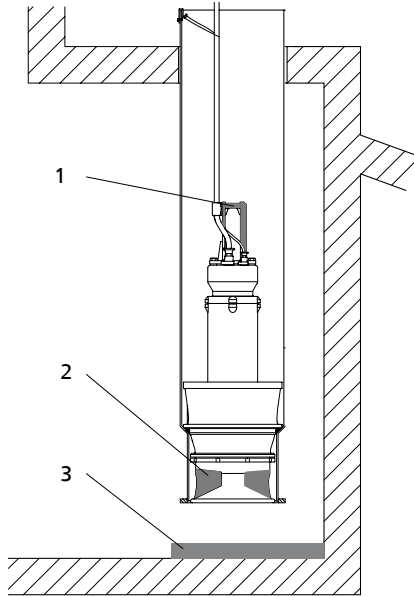

Installation position of the pump set

1	Bail	2	Anti-swirl baffles
3	Flow-straightening vane		

Variant 1 (concrete variant)
Flow-straightening vane cast from concrete

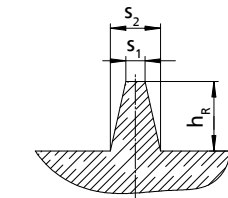

Variant 2
Steel section

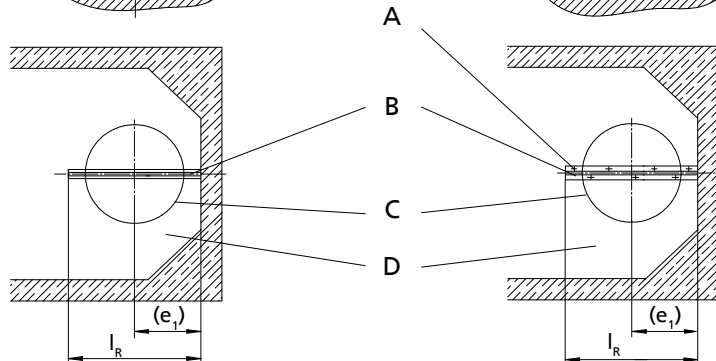
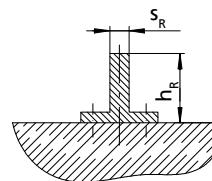

A	Bolted to the floor of the intake chamber	C	Discharge tube
B	Flow-straightening vane centred beneath the discharge tube	D	Intake chamber

43) See installation examples for types BU, CU and DU

44) Length l_R of the flow-straightening vane must be adjusted to the 45° angle of the intake chamber.

Dimensions for installation types BU, CU, DU

Dimensions in [mm]

Size	h_R	s_R	s_1	s_2	$(e_1)^{43)}$		$l_R^{44)}$	
					Design without suction umbrella d_8	Design with suction umbrella d_9	Design without suction umbrella d_8	Design with suction umbrella d_9
					650-364	150	10	20
650-365	150	10	20	60	420	540	835	955
650-404	150	10	20	60	420	540	835	955
650-405	190	10	20	70	420	540	875	1050
800-505	190	10	20	70	500	620	1050	1150
800 - 535	230	10	25	90	500	750	1100	1350
850 - 535	230	10	25	90	525	750	1100	1350
850 - 550	230	10	25	90	525	750	1100	1350
900 - 600	230	10	25	90	550	750	1200	1500
900 - 615	265	12	25	100	550	750	1300	1500
900 - 620	190	10	20	70	550	620	1050	1150
1000 - 600	230	10	25	90	600	750	1200	1500
1000 - 615	265	12	25	100	600	750	1300	1500
1000 - 620	190	10	20	70	600	620	1150	1150
1000 - 655	265	12	25	100	600	850	1300	1500
1300 - 820	335	12	30	120	750	1000	1625	1875

Dimensions for installation types BG, CG, DG

Dimensions [mm]

Size	h_R	s_R	s_1	s_2
650-364	150	10	20	60
650-365	150	10	20	60
650-404	150	10	20	60
650-405	190	10	20	70
800-505	190	10	20	70
800 - 535	230	10	25	90
850 - 535	230	10	25	90
850 - 550	230	10	25	90
900 - 600	230	10	25	90
900 - 615	265	12	25	100
900 - 620	190	10	20	70
1000 - 600	230	10	25	90
1000 - 615	265	12	25	100
1000 - 620	190	10	20	70
1000 - 655	265	12	25	100
1300 - 820	335	12	30	120



KSB SE & Co. KGaA
Turmstraße 92 • 06110 Halle (Germany)
Tel. +49 345 4826-0
www.ksb.com