

Submersible Grey Water Pump

AmaDrainer 3

Installation/Operating Manual



CE

KSB 

Legal information/Copyright

Installation/Operating Manual AmaDrainer 3

Original operating manual

All rights reserved. The contents provided herein must neither be distributed, copied, reproduced, edited or processed for any other purpose, nor otherwise transmitted, published or made available to a third party without the manufacturer's express written consent.

Subject to technical modification without prior notice.

© KSB S.A.S, Sequedin/Lille, France 2023-06-05

Contents

	Glossary	5
1	General.....	6
	1.1 Principles	6
	1.2 Installation of partly completed machinery.....	6
	1.3 Target group.....	6
	1.4 Other applicable documents.....	6
	1.5 Symbols	6
	1.6 Key to safety symbols/markings.....	7
2	Safety	8
	2.1 General.....	8
	2.2 Intended use	8
	2.3 Personnel qualification and training.....	9
	2.4 Consequences and risks caused by non-compliance with this manual	9
	2.5 Safety awareness	9
	2.6 Safety information for the operator/user	9
	2.7 Safety information for maintenance, inspection and installation	10
	2.8 Unauthorised modes of operation	10
3	Transport/Storage/Disposal	11
	3.1 Checking the condition upon delivery	11
	3.2 Transport.....	11
	3.3 Storage/preservation	11
	3.4 Return to supplier.....	12
	3.5 Disposal	12
4	Description.....	13
	4.1 General description	13
	4.2 Product information as per Regulation No. 1907/2006 (REACH).....	13
	4.3 Designation.....	13
	4.4 Name plate.....	13
	4.5 Design details.....	14
	4.6 Configuration and function.....	15
	4.7 Noise characteristics	16
	4.8 Scope of supply.....	16
	4.9 Accessories	16
5	Installation at Site	17
	5.1 Safety regulations.....	17
	5.2 Checks to be carried out prior to installation.....	17
	5.3 Preparations for low water level intake (optional for sizes 301, 303)	18
	5.4 Preparations for cleaning the pump sump (optional for size 322)	19
	5.5 Preparing the pump set	20
	5.6 Adjusting the cut-in level control.....	21
	5.6.1 Setting the cut-in level control via manual mode or external control unit	22
	5.6.2 Setting the cut-in level control via the integrated float switch.....	23
	5.7 Installing the pump set	24
	5.8 Piping	25
	5.8.1 Connecting the piping (stationary installation).....	25
	5.8.2 Connecting the piping (transportable installation)	26
	5.9 Electrical connection	26
6	Commissioning/Start-up/Shutdown	27
	6.1 Commissioning/Start-up.....	27
	6.1.1 Prerequisites for commissioning/start-up	27
	6.1.2 Start-up.....	27

6.2	Operating Limits.....	27
6.2.1	Frequency of starts.....	27
6.2.2	Maximum immersion depth.....	27
6.2.3	Fluid handled.....	28
6.3	Shutdown.....	29
6.3.1	Shutdown.....	29
6.3.2	Measures to be taken for taking the pump set out of service.....	29
6.4	Returning to service.....	29
7	Servicing/Maintenance.....	30
7.1	Safety regulations.....	30
7.2	Servicing/inspection.....	30
7.3	Drainage/cleaning.....	32
7.4	Dismantling / reassembling the pump set.....	34
7.4.1	General information/Safety regulations.....	34
7.5	Replacing Ama-Drainer N by AmaDrainer 3 in an AmaDrainer-Box Mini.....	35
7.5.1	Removing the Ama-Drainer N.....	35
7.5.2	Preparing the AmaDrainer 3.....	36
7.5.3	Installing the AmaDrainer 3.....	39
7.5.4	Replacement kit.....	40
7.6	Recommended spare parts stock.....	41
7.6.1	Spare parts.....	41
8	Trouble-shooting.....	42
9	Related Documents.....	43
9.1	Exploded view and list of components.....	43
10	EU Declaration of Conformity.....	46
11	Certificate of Decontamination.....	47
	Index.....	48

Glossary

Backflow

Waste water flowing back from the sewer into the connected drainage piping

Certificate of decontamination

A certificate of decontamination is enclosed by the customer when returning the product to the manufacturer to certify that the product has been properly drained to eliminate any environmental and health hazards arising from components in contact with the fluid handled.

Close-coupled design

Motor directly fitted to the pump via a flange or a drive lantern

Flood level

Maximum backflow level of waste water in a drainage system

Grey water

Faecal-free waste water

Hydraulic system

The part of the pump in which the kinetic energy is converted into pressure energy

Mat. No.

This identification number is composed of an 8-digit numerical code that uniquely identifies a product entered in SAP.

Pump

Machine without drive, additional components or accessories

Pump set

Complete pump set consisting of pump, drive, additional components and accessories

Submersible motor pump

Submersible motor pumps are floodable, close-coupled units which are not self-priming. The pumps are usually operated completely submerged. They may be operated outside the fluid for short periods of time, until the minimum fluid level has been reached.

Swing check valve

Element of a waste water lifting unit which prevents waste water from flowing back from the discharge line into the waste water lifting unit.

1 General

1.1 Principles

This operating manual is valid for the type series and variants indicated on the front cover.

The operating manual describes the proper and safe use of this equipment in all phases of operation.

The name plate indicates the type series and size, the main operating data, the order number and the order item number. The order number and order item number clearly identify the pump set and serve as identification for all further business processes.

In the event of damage, immediately contact your nearest KSB service facility to maintain the right to claim under warranty.

1.2 Installation of partly completed machinery

To install partly completed machinery supplied by KSB refer to the sub-sections under Servicing/Maintenance.

1.3 Target group

This operating manual is aimed at the target group of trained and qualified specialist technical personnel. (⇒ Section 2.3, Page 9)

1.4 Other applicable documents

Table 1: Overview of other applicable documents

Document	Contents
Sub-supplier product literature	Operating manuals and other product literature describing accessories and integrated machinery components

For accessories and/or integrated machinery components, observe the relevant manufacturer's product literature.







1.5 Symbols

Table 2: Symbols used in this manual

Symbol	Description
✓	Conditions which need to be fulfilled before proceeding with the step-by-step instructions
▷	Safety instructions
⇒	Result of an action
⇔	Cross-references
1. 2.	Step-by-step instructions
	Note Recommendations and important information on how to handle the product

1.6 Key to safety symbols/markings

Table 3: Definition of safety symbols/markings

Symbol	Description
	DANGER This signal word indicates a high-risk hazard which, if not avoided, will result in death or serious injury.
	WARNING This signal word indicates a medium-risk hazard which, if not avoided, could result in death or serious injury.
	CAUTION This signal word indicates a hazard which, if not avoided, could result in damage to the machine and its functions.
	General hazard In conjunction with one of the signal words this symbol indicates a hazard which will or could result in death or serious injury.
	Electrical hazard In conjunction with one of the signal words this symbol indicates a hazard involving electrical voltage and identifies information about protection against electrical voltage.
	Machine damage In conjunction with the signal word CAUTION this symbol indicates a hazard for the machine and its functions.



2 Safety

All the information contained in this section refers to hazardous situations.

In addition to the present general safety information the action-related safety information given in the other sections must be observed.

2.1 General

- This operating manual contains general installation, operating and maintenance instructions that must be observed to ensure safe operation of the system and prevent personal injury and damage to property.
- Comply with all the safety instructions given in the individual sections of this operating manual.
- The operating manual must be read and understood by the responsible specialist personnel/operators prior to installation and commissioning.
- The contents of this operating manual must be available to the specialist personnel at the site at all times.
- Information and markings attached directly to the product must always be complied with and kept in a perfectly legible condition at all times. This applies to, for example:
 - Arrow indicating the direction of rotation
 - Markings for connections
 - Name plate
- The operator is responsible for ensuring compliance with all local regulations not taken into account.

2.2 Intended use

- The pump (set) must only be operated in the fields of application and within the use limits specified in the other applicable documents.
- Only operate pumps/pump sets which are in perfect technical condition.
- Do not operate the pump (set) in partially assembled condition.
- Only use the pump (set) to handle the fluids described in the data sheet or product literature of the pump variant.
- Never operate the pump (set) without the fluid to be handled.
- Observe the minimum flow rate and maximum flow rate indicated in the data sheet or product literature (to prevent overheating, mechanical seal damage, cavitation damage, bearing damage, etc).
- Always operate the pump (set) in the direction of rotation it is intended for.
- Do not throttle the flow rate on the suction side of the pump (to prevent cavitation damage).
- Consult the manufacturer about any use or mode of operation not described in the data sheet or product literature.

2.3 Personnel qualification and training

All personnel involved must be fully qualified to transport, install, operate, maintain and inspect the equipment this manual refers to.

The responsibilities, competence and supervision of all personnel involved in transport, installation, operation, maintenance and inspection must be clearly defined by the operator.

Deficits in knowledge must be rectified by means of training and instruction provided by sufficiently trained specialist personnel. If required, the operator can commission the manufacturer/supplier to train the personnel.

Training on the pump (set) must always be supervised by technical specialist personnel.

This device may be operated by **children** from the age of 8 as well as by persons of limited physical, sensory or mental abilities or lacking experience and knowledge, provided that they are supervised, they have been instructed on how to use this device safely and they understand the hazards it presents. It is impermissible for **children** to play with this device. **Children** must not clean the device or perform any **service work to be carried out by the operator** at the device without supervision.

2.4 Consequences and risks caused by non-compliance with this manual

- Non-compliance with these operating instructions will lead to forfeiture of warranty cover and of any and all rights to claims for damages.
- Non-compliance can, for example, have the following consequences:
 - Hazards to persons due to electrical, thermal, mechanical and chemical effects and explosions
 - Failure of important product functions
 - Failure of prescribed maintenance and servicing practices
 - Hazard to the environment due to leakage of hazardous substances

2.5 Safety awareness

In addition to the safety information contained in this operating manual and the intended use, the following safety regulations shall be complied with:

- Accident prevention, health regulations and safety regulations
- Explosion protection regulations
- Safety regulations for handling hazardous substances
- Applicable standards, directives and laws

2.6 Safety information for the operator/user

- Fit protective equipment (e.g. contact guards) supplied by the operator for hot, cold or moving parts, and check that the equipment functions properly.
- Do not remove any protective equipment (e.g. contact guards) during operation.
- Provide the personnel with protective equipment and make sure it is used.
- Contain leakages (e.g. at the shaft seal) of hazardous fluids handled (e.g. explosive, toxic, hot) so as to avoid any danger to persons and the environment. Adhere to all relevant laws.
- Eliminate all electrical hazards. (In this respect refer to the applicable national safety regulations and/or regulations issued by the local energy supply companies.)
- If stopping the pump does not increase potential risk, fit an emergency-stop control device in the immediate vicinity of the pump (set) during pump set installation.
- Make sure the system cannot be accessed by unauthorised persons (e.g. children).

2.7 Safety information for maintenance, inspection and installation

- Modifications or alterations of the pump (set) are only permitted with the manufacturer's prior consent.
- Use only original spare parts or parts/components authorised by the manufacturer. The use of other parts/components can invalidate any liability of the manufacturer for resulting damage.
- The operator ensures that maintenance, inspection and installation are performed by authorised, qualified specialist personnel who are thoroughly familiar with the manual.
- Only carry out work on the pump (set) during standstill of the pump.
- Only perform work on the pump set when it has been disconnected from the power supply (de-energised).
- The pump (set) must have cooled down to ambient temperature.
- Pump pressure must have been released and the pump must have been drained.
- When taking the pump set out of service always adhere to the procedure described in the manual.
- Decontaminate pumps which handle fluids posing a health hazard.
- As soon as the work has been completed, re-install and re-activate any safety-relevant devices and protective devices. Before returning the product to service, observe all instructions on commissioning. (⇒ Section 6.1, Page 27)

2.8 Unauthorised modes of operation

Never operate the pump (set) outside the limits stated in the data sheet and in this operating manual.

The warranty relating to the operating reliability and safety of the pump (set) supplied is only valid if the equipment is used in accordance with its intended use. (⇒ Section 2.2, Page 8)

3 Transport/Storage/Disposal

3.1 Checking the condition upon delivery

1. On transfer of goods, check each packaging unit for damage.
2. In the event of in-transit damage, assess the exact damage, document it and notify KSB or the supplying dealer and the insurer about the damage in writing immediately.

3.2 Transport

	CAUTION
	<p>Improper transport Damage to the pump (set)!</p> <ul style="list-style-type: none"> ▷ To transport the pump / pump set always use the handle. ▷ Never suspend the pump (set) from the power cable. ▷ Prevent the pump (set) from getting knocked or dropped.

3.3 Storage/preservation

	CAUTION
	<p>Damage during storage due to humidity, dirt or vermin Corrosion/contamination of pump (set)!</p> <ul style="list-style-type: none"> ▷ For outdoor storage cover the pump (set) and accessories with waterproof material and protect against condensation.

	NOTE
	Special preservation measures are not required.

If commissioning is to take place some time after delivery, we recommend that the following measures be taken:

Store the pump (set) in a dry, protected room at constant atmospheric humidity.

If properly stored indoors, the equipment is protected for a maximum of 12 months. New pumps/pump sets are supplied by our factory duly prepared for storage.

For storing a pump (set) which has been operated, observe the instructions in (⇒ Section 6.3.2, Page 29) .

Table 4: Ambient conditions for storage

Ambient condition	Value
Relative humidity	≤ 80 %
Ambient temperature	0 °C to +40 °C

- Well-ventilated
- Dry
- Dust-free
- Shock-free
- Vibration-free

3.4 Return to supplier

1. Prior to returning the product to the supplier, flush and clean it, particularly if it has been used in noxious, explosive, hot or other hazardous fluids.
2. If the product has been used in fluids whose residues could lead to corrosion damage in the presence of atmospheric humidity or could ignite upon contact with oxygen, the product must also be neutralised and treated with anhydrous inert gas to ensure drying.
3. Always complete and enclose a certificate of decontamination when returning the product. (⇒ Section 11, Page 47)
Indicate any safety measures and decontamination measures taken.

	NOTE
	If required, a blank certificate of decontamination can be downloaded from the following web site: www.ksb.com/certificate_of_decontamination

3.5 Disposal

	WARNING
	<p>Fluids, consumables and supplies posing a health hazard Hazard to persons and the environment!</p> <ul style="list-style-type: none"> ▷ Collect and dispose of any preservatives, flushing liquids and fluid residues. ▷ Wear safety clothing and a protective mask, if required. ▷ Observe all legal regulations on the disposal of fluids posing a health hazard.

1. Dismantle the product.
Collect greases and other lubricants during dismantling.
2. Separate and sort the materials, e.g. by:
 - Metals
 - Plastics
 - Electronic waste
 - Greases and other lubricants
3. Dispose of materials in accordance with local regulations or in another controlled manner.

Electrical or electronic equipment marked with the adjacent symbol must not be disposed of in household waste at the end of its service life.

Contact your local waste disposal partner for returns.

If the used electrical or electronic equipment contains personal data, the operator is responsible for deleting it before the equipment is returned.

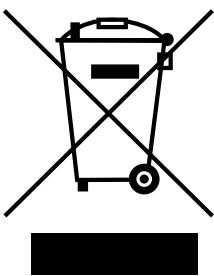

4 Description

4.1 General description

- Grey water-Submersible motor pump
- Pumping seepage water, slightly contaminated waste water, wash water and seawater¹⁾

4.2 Product information as per Regulation No. 1907/2006 (REACH)

For information as per European chemicals regulation (EC) No. 1907/2006 (REACH) see <https://www.ksb.com/en-global/company/corporate-responsibility/reach>.

4.3 Designation

Example: AmaDrainer 301 C

Table 5: Designation key

Code	Description	
AmaDrainer 3	Type series	
0	Free passage [mm]	
	0	10 mm
	2	18 mm
	5	35 mm
1	Characteristic curve	
	1	Characteristic curve 301
	2	Characteristic curve 322
	3	Characteristic curve 303
	4	Characteristic curve 354
C	Material variant	
	C	Variant for aggressive fluids
	_)	Standard variant

4.4 Name plate

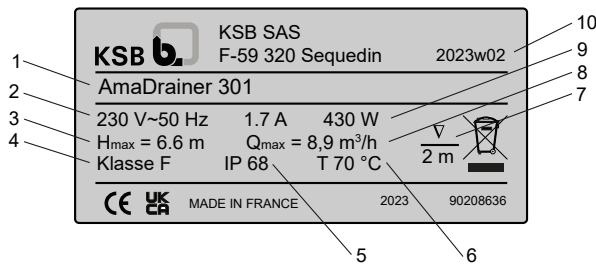

Fig. 1: Name plate (example)

1	Type series, size	6	Maximum fluid temperature
2	Mains voltage, frequency	7	Maximum immersion depth
3	Head	8	Flow rate
4	Thermal class	9	Rated power
5	Enclosure	10	Production year and production week

¹ Material variant C only

² Blank

4.5 Design details

Design

- Fully floodable submersible motor pump
- Close-coupled design
- Single-stage
- Wetted parts made of materials coated with anti-corrosive
- Maximum immersion depth: 2 m
- Sizes 301, 303, 322:
 - Integrated swing check valve
- Size 322:
 - Integrated pump sump cleaning option

Installation

- Vertical installation
- Wet-installed transportable model

Drive

- Jacket-cooled single-phase AC motor
- 230 V, 50 Hz
- Frequency of starts ≤ 30 starts/hour
- Integrated temperature switch
- Enclosure IP68 (permanently submerged) to EN 60529/ IEC 529
- Power cable incl. shockproof plug

Shaft seal

- Drive end, 1 shaft seal ring
- Pump-end, 1 shaft seal ring
- Grease reservoir between the seals for lubrication
- Grease-packed for life
- Maintenance-free

Bearings

- Rolling element bearings
- Grease-packed for life
- Maintenance-free

Automation

- Pump controlled via integrated float switch
- Pump controlled by external control unit

4.6 Configuration and function

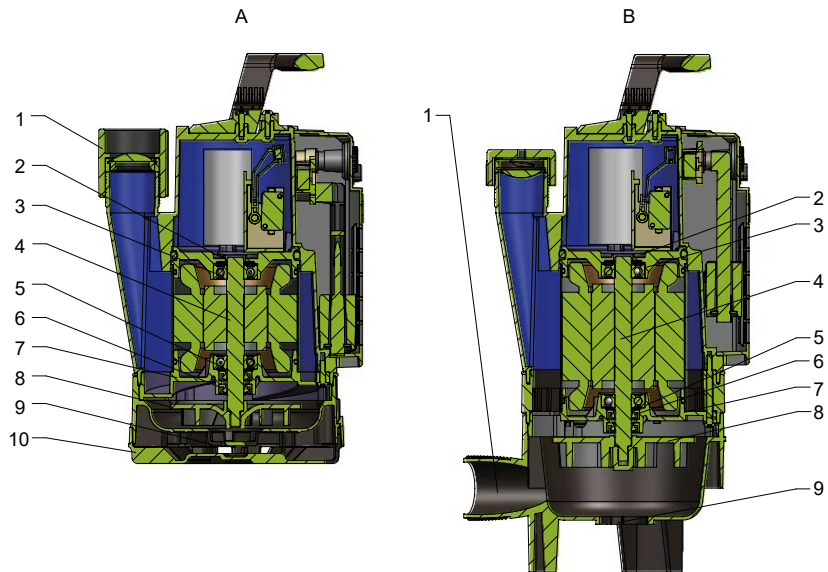

Fig. 2: Illustration of the submersible waste water pump

A	Sizes 301, 303, 322	5	Rolling element bearing
B	Size 354	6	Shaft seal
1	Discharge nozzle	7	Casing cover
2	Bearing bracket	8	Impeller
3	Rolling element bearing	9	Foot opening
4	Shaft	10	Suction strainer

Design The pump is designed with a fluid inlet axial to the centreline of the pump set and a fluid outlet parallel to the centreline, leading upwards. For size 354 the fluid outlet is horizontal to the centreline, arranged at the impeller level.

The hydraulic system is closed off by the casing wall on the discharge side of the impeller and runs in rolling element bearings (3, 5). The rolling element bearings (3, 5) are supported by bearing brackets (2) arranged at the pump casing and casing cover.

The shaft (4) enters through the casing wall and casing cover; it links the hydraulic system with the drive.

It is sealed to atmosphere by a shaft seal (6) consisting of two shaft seal rings in tandem arrangement with a grease reservoir fitted in between. The shaft seal is grease-packed for life and maintenance-free.

Function The fluid handled enters the pump via the suction strainer (10) / foot opening (9). The rotating impeller (8) accelerates the fluid handled outward. In the flow passage of the pump casing the kinetic energy of the fluid handled is converted into pressure energy. The fluid handled is pumped to the discharge nozzle (1), where it leaves the pump.

4.7 Noise characteristics

Sound pressure level < 70 dB(A)

4.8 Scope of supply

Depending on the model, the following items are included in the scope of supply:

- Pump set
- Installation/operating manual
- Size 301:
 - Discharge-side adapter, graded (connection Rp 1 1/4 to Rp 3/4, DN 25 or DN 32)
- Sizes 301, 303:
 - Removable suction strainer enabling low water level intake
- Sizes 301, 303, 322:
 - Integrated swing check valve
 - Connection socket with internal thread
- Size 322:
 - Integrated pump sump cleaning option
- Size 354³⁾:
 - 90° bend (cross-section 1 1/2 inches) for vertical discharge



4.9 Accessories

Accessories such as switchgear / control units, valves etc. see type series booklet.

³ Not available for the UK

5 Installation at Site

5.1 Safety regulations



	<p>⚠ DANGER</p> <p>Unsuitable electrical installation Danger to life!</p> <ul style="list-style-type: none"> ▷ Make sure the electrical installation meets the VDE 100 installation rules (sockets with earthing terminals). ▷ Make sure the electric mains is equipped with a residual current device of max. 30 mA. ▷ Always have the electrical connections installed by a trained electrician. ▷ Only use the plug and power cable supplied.
	<p>⚠ DANGER</p> <p>Use in an outdoor area Danger of death from electric shock!</p> <ul style="list-style-type: none"> ▷ Any extension cables must match the quality of the supplied power cable. ▷ Never expose electrical connections to any moisture.
	<p>⚠ DANGER</p> <p>Continuous pump operation in swimming pools, garden ponds or similar Danger of death from electric shock!</p> <ul style="list-style-type: none"> ▷ Make sure that nobody is in the water while the pump is in operation. ▷ Only use the pump for draining swimming pools, garden ponds, etc. (It is impermissible to use this pump as a recirculation pump, for example.)

5.2 Checks to be carried out prior to installation

Before beginning with the installation check the following:

- All structural work required has been checked and prepared in accordance with the dimensions in the outline drawing.
- The data on the name plate of the pump set has been checked. The pump set must be suitable for operation on the available power supply network. (⇒ Section 4.4, Page 13)
- The fluid to be handled matches the description of suitable fluids. (⇒ Section 6.2.3.1, Page 28)

5.3 Preparations for low water level intake (optional for sizes 301, 303)

	<p>NOTE</p> <p>Low water level intake can only be used when the pump is in manual mode or controlled by an external control unit.</p>
	<p>NOTE</p> <p>When the residual water level of 2 mm is reached there is a risk of dry running. If dry running occurs, switch off the pump set.</p>
	<p>NOTE</p> <p>The suction strainer is fastened to the pump set with clamps. In addition, bolts/screws (size 4 x 12 mm) can be used.</p>

In preparation for low water level intake carry out the following steps:

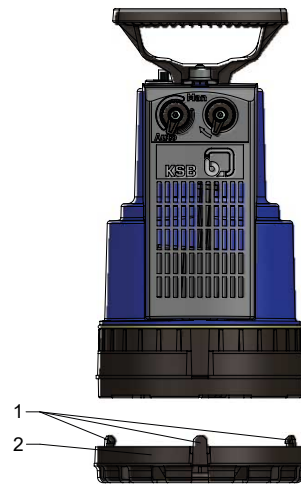



Fig. 3: Removing the suction strainer

- ✓ The pump set has been de-energised and secured against unintentional start-up.
- 1. If applicable, undo the bolts/screws (size 4 x 12 mm) at the suction strainer (2) and store them.
- 2. Pull the clamps (1) outwards. Remove and store the suction strainer.

5.4 Preparations for cleaning the pump sump (optional for size 322)

	<p>NOTE</p> <p>AmaDrainer 322 pumps are delivered with the cleaning openings in the pump foot closed. If the pump set is to be used for cleaning the pump sump, the cleaning openings have to be opened by the customer.</p>
	<p>NOTE</p> <p>The pump sump is cleaned by an intended leakage flow from the hydraulic system. The operating data of the pump set will only be slightly influenced by this process.</p>

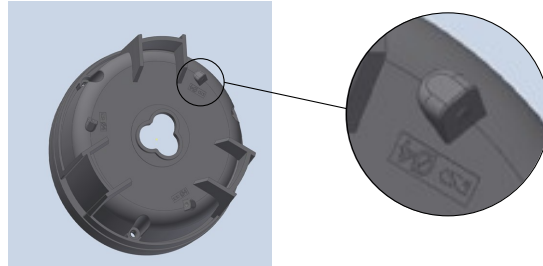

Fig. 4: Cleaning opening

- ✓ The pump set has been de-energised and secured against unintentional start-up.
 - ✓ An electric drill and a drill bit (4 mm in diameter) are available.
1. Place the pump set down on its side.
 2. Carefully drill open the cleaning openings with a drill (4 mm in diameter).
 3. Debur the drilled holes.

5.5 Preparing the pump set

Sizes 301, 303, 322

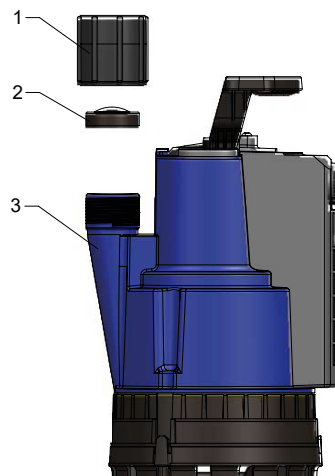



Fig. 5: Preparing the pump set, sizes 301, 303, 322

1	Connection socket	3	Discharge nozzle
2	Swing check valve		

1. Position the swing check valve (2) on the discharge nozzle (3) as shown in the illustration. Make sure the swing check valve (2) opens upwards.
2. Screw the connection socket (1) with the long thread onto the discharge nozzle (3) until hand-tight.

Size 354

	NOTE
	The check valve is not included in the scope of supply. See type series booklet, accessories P10.

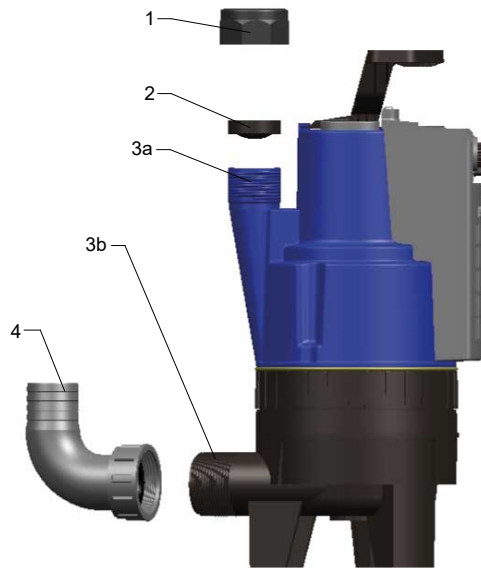

Fig. 6: Preparing the pump set, size 354

1	Cap	3b	Discharge nozzle, horizontal
2	Swing check valve	4	90° bend
3a	Discharge nozzle, axial ⁴⁾		

1. Position the swing check valve (2) on the discharge nozzle (3a) as shown in the illustration⁴⁾. Make sure the swing check valve (2) opens downwards (vent function).
2. Screw on the cap (1) until hand-tight.
3. Prepare the connection to the piping.
 - ⇒ Stationary installation: Fit a check valve in the piping downstream of the discharge nozzle (3b).
 - ⇒ Transportable installation: Screw the 90° bend (4) to the discharge nozzle (3b) until hand-tight. If required, fit a check valve downstream of the 90° bend (4).

5.6 Adjusting the cut-in level control

Settings for starting up and stopping the pump set can be made as follows:

- Manual mode (⇒ Section 5.6.1, Page 22)
- External control unit (⇒ Section 5.6.1, Page 22)
- Integrated float switch (⇒ Section 5.6.2, Page 23)

⁴ The axial discharge nozzle is designed for venting purposes. Connect piping to the horizontal discharge nozzle only.

5.6.1 Setting the cut-in level control via manual mode or external control unit

	NOTE
	Low water level intake can only be used when the pump is in manual mode or controlled by an external control unit.
	NOTE
	If the pump set is in manual mode or controlled via an external control unit, the fill level for pump start-up must never be below the fill levels indicated.

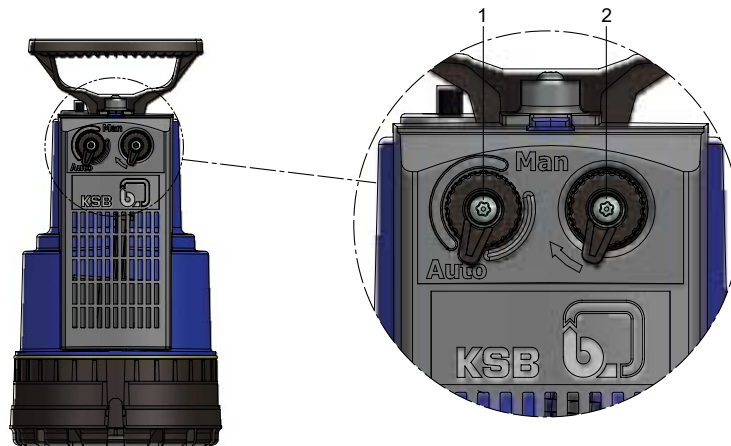

Fig. 7: Setting the cut-in level control via manual mode or external control unit

Table 6: Minimum fill level depending on the pump size

Size	Minimum fill level	Minimum fill level for low water level intake
	[mm]	[mm]
301	50	40
303	50	40
322	75	-
354	110	-

- ✓ The pump set has been de-energised and secured against unintentional start-up.
 - ✓ If using a control unit: The original operating manual of the control unit is available.
 - ✓ For low water level intake: The suction strainer has been properly removed. (⇒ Section 5.3, Page 18)
1. Turn the dial (2) as far as it will go and hold it in this position.
 2. Set the dial (1) to **Man**.
 3. Briefly energise the pump set and carry out a test run.
 4. If using a control unit: Connect the control unit and the pump set as described in the operating manual of the control unit.

5.6.2 Setting the cut-in level control via the integrated float switch

	NOTE
	Low water level intake can only be used when the pump is in manual mode or controlled by an external control unit.

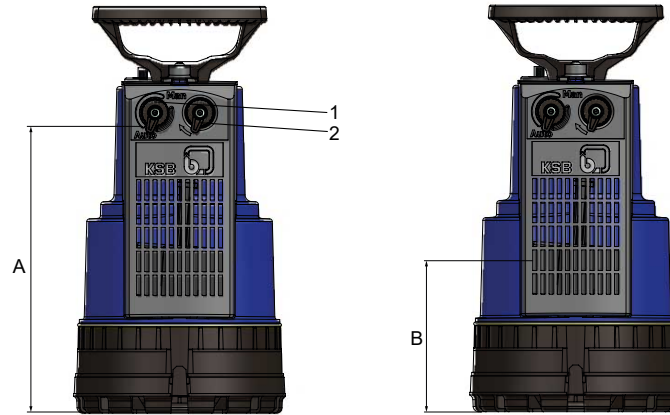

Fig. 8: Setting the cut-in level control via the integrated float switch

Table 7: Cut-in level and cut-out level depending on the pump size

Size	Switching point A (ON)	Switching point B (OFF)
	[mm]	[mm]
301	210	110
303	240	140
322	260	160
354	290	190

- ✓ The pump set has been de-energised and secured against unintentional start-up.
- 1. Set the dial (1) to **Auto** .
- 2. Turn the dial (2) as far as it will go. Do not hold it in this position. Check that the float can move freely.
 - ⇒ Switching is indicated by a clicking sound.
- 3. Briefly energise the pump set and carry out a test run.

5.7 Installing the pump set

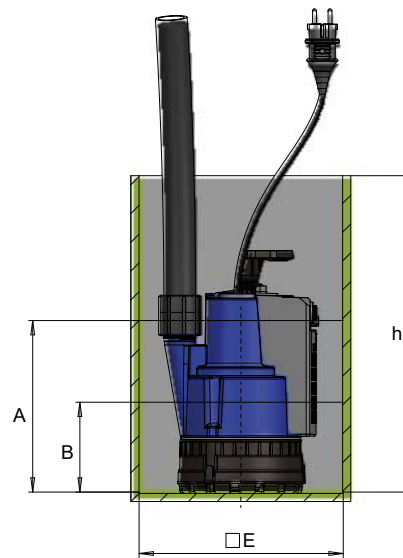

Fig. 9: Installing the pump set (example)

A	Cut-in level	B	Cut-out level
---	--------------	---	---------------

Table 8: Recommended installation dimensions

Size	□ E	h
	[mm]	[mm]
301	≥ 250 × 200	320
303	≥ 250 × 200	350
322	≥ 250 × 200	370
354	≥ 430 × 300	400

- ✓ The place of installation is solid and level.
- ✓ The recommended installation dimensions have been observed.
 1. For installation in tanks / sumps that are difficult to access fasten a suitable tool (e.g. rope) to the handle, and lower the pump set down.
 2. Position the pump set at the place of installation so it is free-standing and there is some space on all sides.

5.8 Piping

**NOTE**

To prevent any damage if backflow occurs in the sewer, the discharge line has to include a backflow loop. The invert of the discharge line at its highest point has to be above the flood level (usually the street level).

5.8.1 Connecting the piping (stationary installation)

Sizes 301, 303, 322

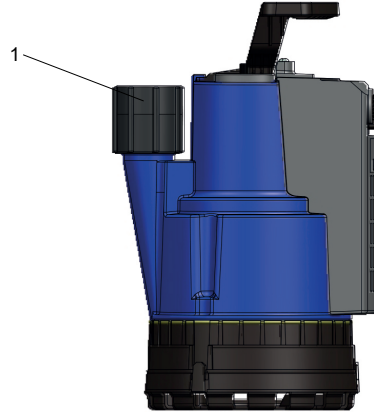
**Fig. 10:** Connecting the piping, sizes 301, 303, 322

1. Connect the piping (inside diameter 32 mm, connection G 1 $\frac{1}{4}$) to the connection socket (1).

Size 354

**Fig. 11:** Connecting the piping, size 354

1. Connect the piping (inside diameter 40 mm, connection G 1 $\frac{1}{2}$) to the discharge nozzle (1).

5.8.2 Connecting the piping (transportable installation)

Sizes 301, 303, 322

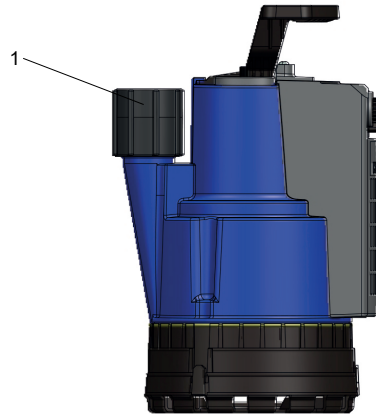

Fig. 12: Connecting the piping, sizes 301, 303, 322

- ✓ Drain hose set A 25 B (see type series booklet, accessory P21) is available.
- 1. Connect the hose (inside diameter 30 mm) to the connection socket (1).
- 2. Fasten the hose with a hose clip.

Size 354

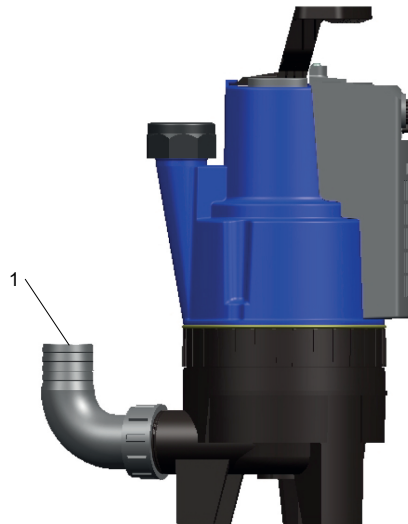

Fig. 13: Connecting the piping, size 354

- 1. Connect the hose (inside diameter 40 mm) to the 90° bend (1).
- 2. Fasten the hose with a hose clip.

5.9 Electrical connection

	<p>⚠ WARNING</p>
	<p>Impeller freely accessible through the foot opening Risk of injury, limbs can be pulled into or crushed by machinery!</p> <ul style="list-style-type: none"> ▷ Never reach into the foot opening when the pump set is running. ▷ Disconnect the pump set from the power supply during maintenance / cleaning.

- ✓ The cut-in level control has been set properly. (⇒ Section 5.6, Page 21)
- 1. Plug the power plug into the socket.
 - ⇒ Pump set is ready for operation.
- 2. Perform a test run.

2332.8/05-EN

6 Commissioning/Start-up/Shutdown



6.1 Commissioning/Start-up

6.1.1 Prerequisites for commissioning/start-up

Before commissioning/starting up the pump set, make sure that the following conditions are met:

- The operating data has been verified.
- The pump (set) has been installed and connected as described in this manual.
- The pump set has been properly connected to the power supply and is equipped with all protection devices. (⇒ Section 5.9, Page 26)

6.1.2 Start-up

	 WARNING
	<p>Impeller freely accessible through the foot opening Risk of injury, limbs can be pulled into or crushed by machinery!</p> <ul style="list-style-type: none"> ▷ Never reach into the foot opening when the pump set is running. ▷ Disconnect the pump set from the power supply during maintenance / cleaning.

Control via manual mode or external control unit

Manual mode:

- When energised, the pump set is ready for operation.

External control unit:

- When energised, the pump set is ready for operation.
- The pump set starts up automatically when the cut-in conditions are reached. (⇒ Section 5.6.1, Page 22)

Control via integrated float switch

- When energised, the pump set is ready for operation.
- The pump set starts up automatically when the float reaches switching point A. (⇒ Section 5.6.2, Page 23)

6.2 Operating Limits

6.2.1 Frequency of starts

	CAUTION
	<p>Excessive frequency of starts Risk of damage to the motor!</p> <ul style="list-style-type: none"> ▷ Never exceed the specified frequency of starts.

- The maximum permissible number of starts per hour is 30.

6.2.2 Maximum immersion depth

The maximum permissible immersion depth is 2 m.

6.2.3 Fluid handled

6.2.3.1 Permissible fluids to be handled

	CAUTION
	<p>Unsuitable fluids Damage to the pump!</p> <ul style="list-style-type: none"> ▷ Never use the pump to handle corrosive, combustible or explosive fluids. ▷ Never use the pump to handle waste water containing faeces. ▷ Do not use the pump for foodstuff applications.

- Sizes 301, 303:
 - Solid particles with a particle size of up to 10 mm
- Size 322:
 - Solid particles with a particle size of up to 18 mm
- Size 354:
 - Solid particles with a particle size of up to 35 mm

Material variant A (standard variant)

- Slightly contaminated grey water ($\leq 70\text{ °C}$)
- Wash water (up to 90 °C max. for short periods $t \leq 3$ minutes)
- Waste water without faeces
- Seepage water
- River water, lake water and groundwater

Material variant C (for aggressive fluids)

- Seawater ($\leq 20\text{ °C}$)
- Brackish water
- Water containing salt ($\leq 20\text{ °C}$)

6.2.3.2 Fluid temperature

	CAUTION
	<p>Incorrect fluid temperature Damage to the pump (set)!</p> <ul style="list-style-type: none"> ▷ Only operate the pump (set) within the temperature limits indicated.

- $\leq +70\text{ °C}$ (continuous operation)
- $\leq +90\text{ °C}$ (short-time operation up to 3 minutes.)

6.3 Shutdown

6.3.1 Shutdown

Control via manual mode or external control unit



NOTE

When the residual water level is reached there is a risk of dry running. If dry running occurs, switch off the pump set.

Manual mode:

- To completely shut down the pump set disconnect it from the power supply.

External control unit:

- The pump set stops automatically when the cut-out conditions are reached. (⇒ Section 5.6.1, Page 22)
- To completely shut down the pump set disconnect it from the power supply.

Control via integrated float switch

- The pump set stops automatically when the float reaches switching point B. (⇒ Section 5.6.2, Page 23)
- To completely shut down the pump set disconnect it from the power supply.

6.3.2 Measures to be taken for taking the pump set out of service







- ✓ The pump set has been shut down properly. (⇒ Section 6.3.1, Page 29)
 1. Let the pump set cool down for a minimum of 10 minutes.
 2. Disconnect the pump from the discharge line.
 3. Remove the pump set from the tank / sump.
 4. Drain / clean the pump set. (⇒ Section 7.3, Page 32)
 5. Store the pump set if necessary. (⇒ Section 3.3, Page 11)

6.4 Returning to service

- ✓ The pump set has been properly shut down and cleaned. (⇒ Section 7.3, Page 32)
- ✓ The measures for servicing / maintenance have been carried out. (⇒ Section 7.2, Page 30)
 1. Install the pump set. (⇒ Section 5.7, Page 24)
 2. Connect the piping. (⇒ Section 5.8, Page 25)
 3. Connect the power supply. (⇒ Section 5.9, Page 26)
 4. Perform the start-up procedure. (⇒ Section 6.1, Page 27)

7 Servicing/Maintenance

7.1 Safety regulations

	<p>⚠ DANGER</p> <p>Power supply not disconnected Danger to life!</p> <ul style="list-style-type: none"> ▷ Pull the mains plug and secure the pump against unintentional start-up.
	<p>⚠ DANGER</p> <p>Work on the pump set by unqualified personnel Danger of death from electric shock!</p> <ul style="list-style-type: none"> ▷ Have pump components modified and dismantled by authorised personnel only.
	<p>⚠ WARNING</p> <p>Impeller freely accessible through the foot opening Risk of injury, limbs can be pulled into or crushed by machinery!</p> <ul style="list-style-type: none"> ▷ Never reach into the foot opening when the pump set is running. ▷ Disconnect the pump set from the power supply during maintenance / cleaning.
	<p>⚠ WARNING</p> <p>Hot surface Risk of injury!</p> <ul style="list-style-type: none"> ▷ Allow the pump set to cool down to ambient temperature.
	<p>⚠ WARNING</p> <p>Insufficient stability Risk of crushing hands and feet!</p> <ul style="list-style-type: none"> ▷ During assembly/dismantling, secure the pump (set)/pump parts to prevent tilting or tipping over.
	<p>⚠ WARNING</p> <p>Fluids handled, consumables and supplies posing a health hazard Hazard to persons and the environment!</p> <ul style="list-style-type: none"> ▷ Clean the pump prior to any maintenance and installation work. ▷ Make sure persons cannot come into contact with the fluid handled.
	<p>NOTE</p> <p>If the power cable is damaged, replace the complete pump set. The power cable is not designed to be replaced.</p>

7.2 Servicing/inspection

The pump set is almost maintenance-free.

Cleaning the pump set and checking the condition of the pump set and power cable once a year is sufficient.
If severely contaminated (e.g. by sand, fibres, sludge) clean and check the equipment every three months.

7.3 Drainage/cleaning

	⚠ WARNING
	<p>Fluids, consumables and supplies which are hot or pose a health hazard Hazard to persons and the environment!</p> <ul style="list-style-type: none"> ▷ Collect and properly dispose of flushing fluid and any residues of the fluid handled. ▷ Wear safety clothing and a protective mask, if required. ▷ Observe all legal regulations on the disposal of fluids posing a health hazard.
	NOTE
	<p>Flush and clean the pump set before transporting it to the workshop. Provide a certificate of decontamination for the pump set.</p>
	NOTE
	<p>The pump will drain automatically when it is taken out of the fluid handled.</p>

Sizes 301, 303, 322

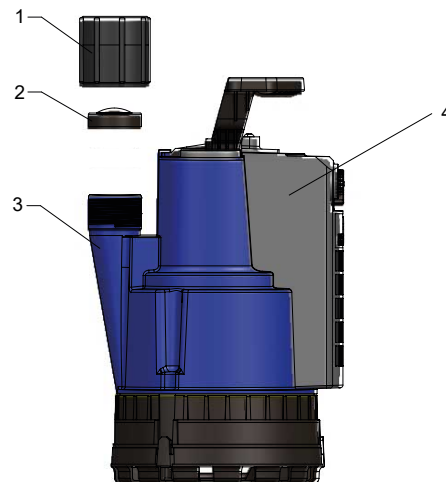
Fig. 14: Draining / cleaning the pump set, sizes 301, 303, 322

1	Connection socket	3	Discharge nozzle
2	Swing check valve	4	Cover of the automatic switchgear

- ✓ The pump set has cooled down for a minimum of 10 minutes. It has been prepared for cleaning. (⇒ Section 6.3.2, Page 29)
- 1. Undo the connection socket (1) from the discharge nozzle (3). Remove the swing check valve (2).
- 2. Remove the screw at the cover of the automatic switchgear (4). Remove the cover.
- 3. Clean the pump set and add-on parts with a suitable tool (e.g. water hose). To do so, point the water jet into the discharge nozzle (3).
- 4. Clean the automatic switchgear and check that the components can move freely.
- 5. Leave the pump set and add-on parts to dry.
- 6. Position the swing check valve (2) on the discharge nozzle (3) as shown in the illustration. Make sure the swing check valve (2) opens upwards.

7. Screw the connection socket (1) with the long thread onto the discharge nozzle (3) until hand-tight.
8. Mount the automatic switchgear.
9. Fasten the cover of the automatic switchgear (4) by screwing in the corresponding screw hand-tight.

Size 354

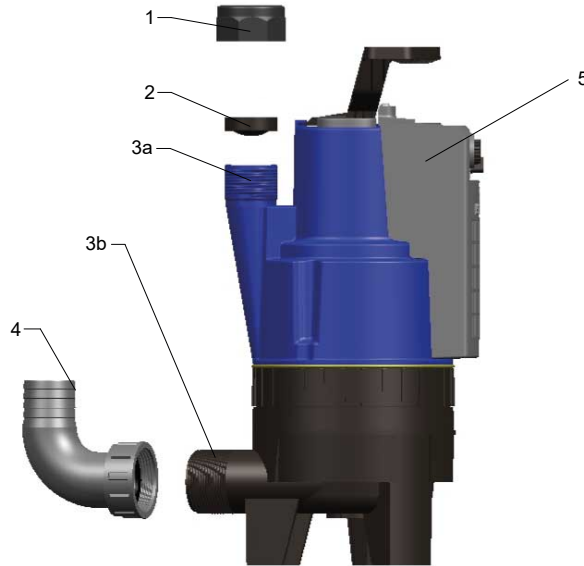

Fig. 15: Draining / cleaning the pump set, size 354

1	Cap	4	90° bend
2	Swing check valve	5	Cover of the automatic switchgear
3	Discharge nozzle		

- ✓ The pump set has cooled down for a minimum of 10 minutes. It has been prepared for cleaning. (⇒ Section 6.3.2, Page 29)
1. For transportable installation with hose connection: Remove the 90° bend (4).
 2. Remove the cap (1) from the discharge nozzle (3). Remove the swing check valve (2).
 3. Remove the screw at the cover of the automatic switchgear (5). Remove the cover.
 4. Clean the pump set and add-on parts with a suitable tool (e.g. water hose). To do so, point the water jet into the discharge nozzle (3).
 5. Clean the automatic switchgear and check that the components can move freely.
 6. Leave the pump set and add-on parts to dry.
 7. Position the swing check valve (2) on the discharge nozzle (3a) as shown in the illustration. Make sure the swing check valve (2) opens downwards.
 8. Screw on the cap (1) until hand-tight.
 9. For transportable installation with hose connection: Screw the 90° bend (4) to the discharge nozzle (3b) until hand-tight.
 10. Mount the automatic switchgear.
 11. Fasten the cover of the automatic switchgear (4) by screwing in the corresponding screw hand-tight.

7.4 Dismantling / reassembling the pump set

7.4.1 General information/Safety regulations



Dismantling/reassembly work must be effected by authorised specialist personnel only.

**NOTE**

All maintenance work, service work and installation work can be carried out by KSB Service or authorised workshops. Find your contact in the attached Addresses booklet or visit <https://www.ksb.com/en-global/contact>.

7.5 Replacing Ama-Drainer N by AmaDrainer 3 in an AmaDrainer-Box Mini

7.5.1 Removing the Ama-Drainer N

	<p style="background-color: #e67e22; color: white; padding: 2px;">⚠ DANGER</p> <p>Power supply not disconnected Danger to life! ▷ Pull the mains plug and secure the pump against unintentional start-up.</p>
	<p style="background-color: #f39c12; color: white; padding: 2px;">⚠ WARNING</p> <p>Fluids handled, consumables and supplies which are hot and/or pose a health hazard Hazard to persons and the environment! ▷ Collect and properly dispose of flushing fluid and any fluid residues. ▷ Wear safety clothing and a protective mask if required. ▷ Observe all legal regulations on the disposal of fluids posing a health hazard.</p>
	<p style="background-color: #2980b9; color: white; padding: 2px;">NOTE</p> <p>The sensors of the Ama-Drainer N are required for the AmaDrainer 3 replacement pump.</p>

- ✓ The pump set has been de-energised and secured against unintentional start-up.
- 1. Undo three screws 900 with a suitable tool and take off cover 160 of the grey water lifting unit.
- 2. Undo pipe clamp 733 at the discharge connection and store the pipe clamp.
 - ⇒ The fluid handled contained in the discharge line will flow back into the collecting tank.
- 3. Pull hose 719 off the discharge connection.
- 4. If a plug has been fitted in the entry for the electric cable, remove and clean the plug.
- 5. Pull the power cable out through the cable entry.
- 6. Turn the pump set until it disengages from the locking devices.
- 7. Lift the pump set out of the collecting tank.
 - ⇒ The pump set will be automatically drained when it is taken out of the fluid handled.
- 8. Always flush the collecting tank if it has been used for handling noxious, hot or other hazardous fluids.
- 9. Remove float 81-45 from segment 59-49. Clean and store the float.

7.5.2 Preparing the AmaDrainer 3

- ✓ The replacement kit is available. (⇒ Section 7.5.4, Page 40)
- ✓ The AmaDrainer 301 submersible motor pump (AmaDrainer Box Mini) or AmaDrainer 301 C submersible motor pump (AmaDrainer Box Mini C) is available.
- ✓ Float 74-4 (incl. float lever) of the Ama-Drainer N is available.

1. Undo screw 900.3.

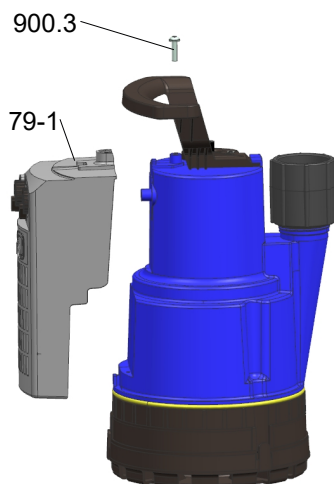

Fig. 16: Removing the automatic switchgear

2. Remove automatic switchgear 79-1.
3. If applicable, undo the bolts/screws (size 4 × 12 mm) at the suction strainer (2) and store them.
4. Pull the clamps (1) outwards. Remove and store the suction strainer (2).

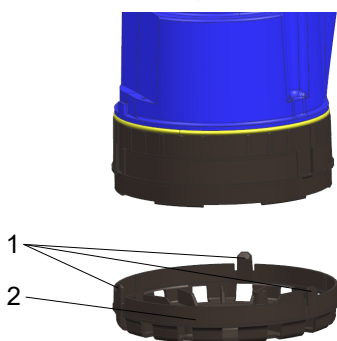

Fig. 17: Removing the suction strainer

5. Undo the threaded double union (3) from the discharge nozzle (5).
6. Remove and store the swing check valve (4).

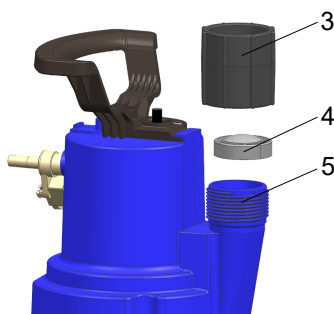

Fig. 18: Preparing the discharge nozzle

7. Undo screw 900.1.

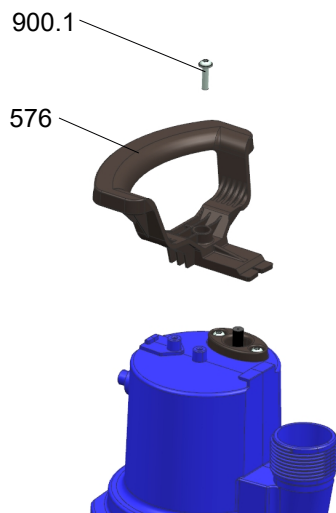

Fig. 19: Removing the handle

8. Remove handle 576.
9. Fit the foot adapter (included in the replacement kit) to the pump foot with screws (size 4 × 12 mm). Tighten the screws hand-tight. Observe the position of the lock jaws (6).

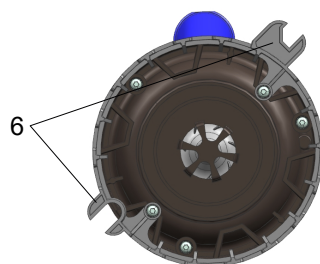

Fig. 20: Fitting the foot adapter

10. Fit the sensor guide (8) (included in the replacement kit) in the corresponding surface area (7) of the pump casing, opposite the discharge nozzle. Slide the sensor guide in from the top, exerting light pressure, until you can hear its snap-fit connection engage at the foot adapter.

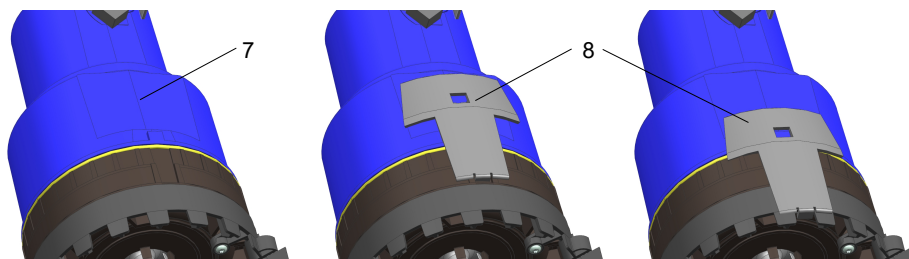

Fig. 21: Fitting the sensor guide

11. Fit segment 59-49 (included in the replacement kit) on the protrusion provided.

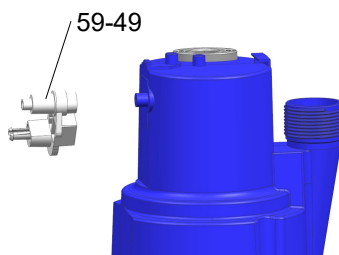

Fig. 22: Fitting the segment

12. Slide the anti-lift protection (9) (included in the replacement kit) over segment 59-49. Fasten it with the screw (size 3 × 16 mm). Tighten the screw hand-tight. Segment 59-49 has to be held firmly in place by the anti-lift protection (A) and still be able to move freely.

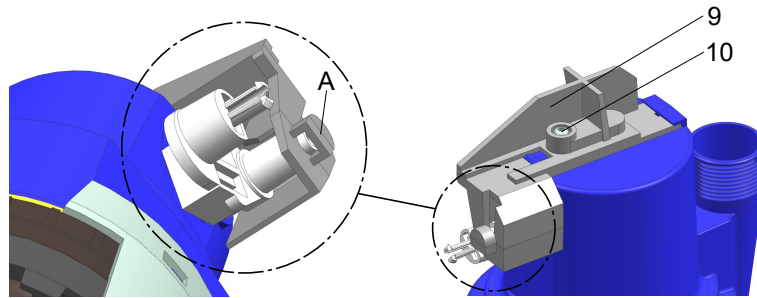

Fig. 23: Fitting the anti-lift protection

13. Clip the float 81-45 (of Ama-Drainer N) onto segment 59-49.

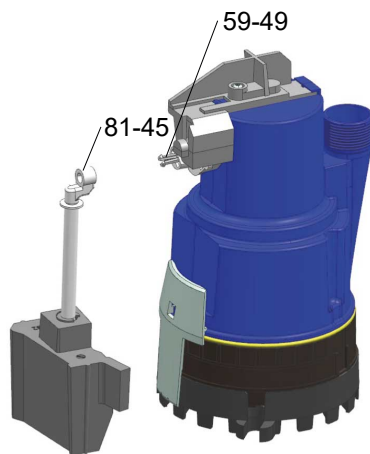

Fig. 24: Fitting the float incl. float lever

7.5.3 Installing the AmaDrainer 3

- ✓ Ama-Drainer N has been removed properly. (⇒ Section 7.5.1, Page 35)
 - ✓ AmaDrainer 3 has been prepared properly. (⇒ Section 7.5.2, Page 36)
 - ✓ The operating manual of the grey water lifting unit is available.
1. Engage the lock jaws of AmaDrainer 3 in the locking devices (1) of the collecting tank.

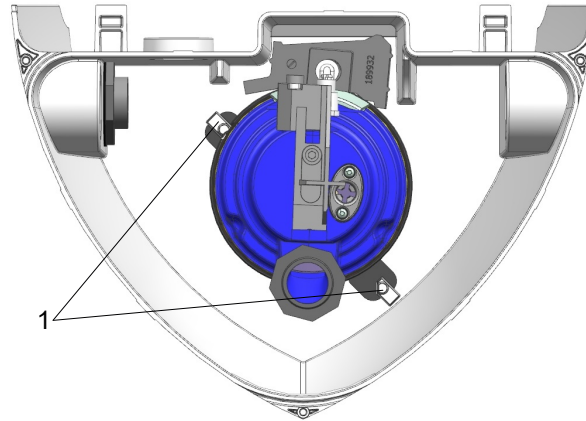

Fig. 25: Engaging the lock jaws in the locking devices

2. Place the previously removed swing check valve (3) of AmaDrainer 3 on the discharge nozzle. Make sure the swing check valve (3) opens upwards.
3. Screw fitting 720.01 (2) (included in the replacement kit) on the discharge nozzle. Tighten it hand-tight.

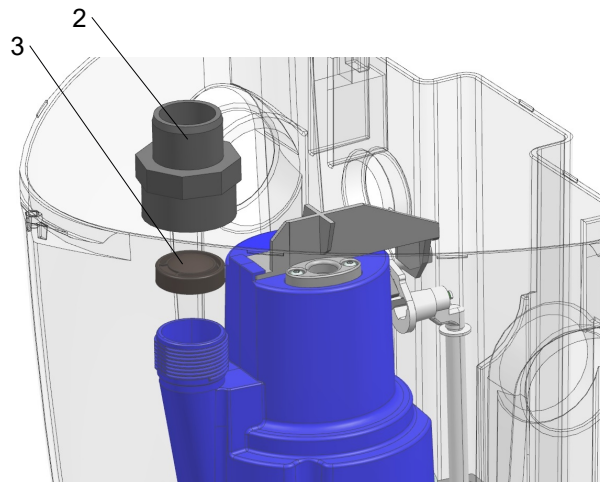

Fig. 26: Fitting the fitting incl. the previously removed swing check valve

4. Pre-assemble hoses 719 (included in the replacement kit) with the hose connection (A) and four pipe clamps 733. The screws of the pipe clamps in the middle have to be located at the bottom.

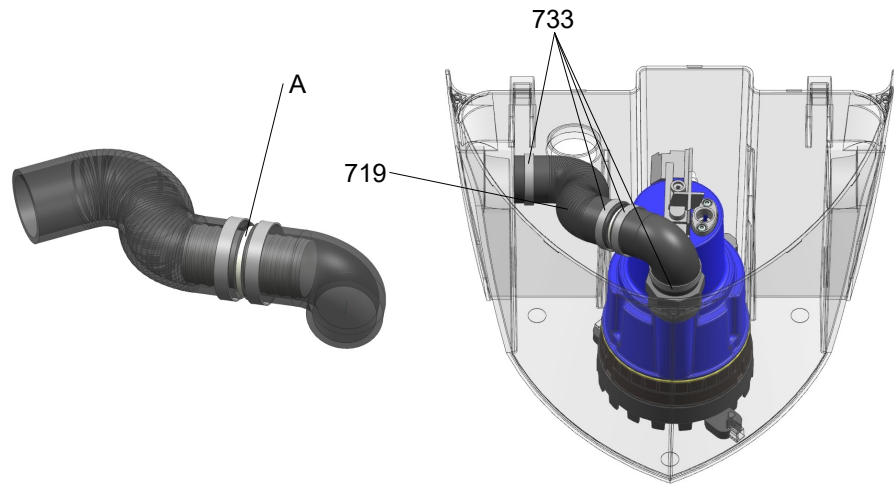



Fig. 27: Fitting the flexible tube (example)

5. Connect pre-assembled flexible tube to fitting 720.01 of the pump set and to the discharge line connection of the collecting tank.
6. Tighten the screws of pipe clamps 733 hand-tight.
7. Route and connect the power cable in accordance with the operating manual of the grey water lifting unit.
8. Mount the cover in accordance with the operating manual of the grey water lifting unit.
9. Carry out a test run for several start/stop cycles.

7.5.4 Replacement kit

Table 9: Replacement kit

Item	Description	Connection	AmaDrainer				Mat. No.	[kg]
			301	303	322	354		
P36 	Replacement kit for AmaDrainer Box Mini For replacing an AmaDrainer N installed in AmaDrainer Box Mini by an AmaDrainer 3 Comprising: installation parts and discharge line	-	x ⁵⁾	-	-	-	19066504	0,4



⁵⁾ Order the replacement kit in addition to the required AmaDrainer 3.

7.6 Recommended spare parts stock



It is not necessary to keep spare parts on stock.

7.6.1 Spare parts

Table 10: Overview of spare parts

Part No.	Description	AmaDrainer				Mat. No.	[kg]
		301	303	322	354		
79-1 	Repair set for automatic switchgear	X	X	X	X	01833946	0,16
576 	Handle	X	X	X	X	01834007	0,05
747 + 73-4 -	Swing check valve with connection socket	X	X	X	-	40990870	0,06
748 	Suction strainer	X	X	-	-	01834008	0,08

8 Trouble-shooting

	 WARNING
	<p>Improper work to remedy faults</p> <p>Risk of injury!</p> <ul style="list-style-type: none"> ▷ For any work performed to remedy faults, observe the relevant information given in this operating manual and/or in the product literature provided by the accessories manufacturer.

If problems occur that are not described in the following table, consultation with the KSB service is required.

Table 11: Trouble-shooting

Faults	Possible cause	Remedy ⁶⁾
Pump is running, but does not or hardly deliver.	Hydraulic system is clogged.	Clean the hydraulic system. (⇒ Section 7.3, Page 32)
	Discharge line is clogged.	Check the discharge line. If necessary, clean and flush it.
	Discharge line is closed.	Open all accessories fitted at the discharge line.
	Swing check valve fitted for the opposite direction of flow.	Fit the swing check valve for the correct direction of flow. (⇒ Section 5.5, Page 20)
	Swing check valve is clogged.	Clean the swing check valve.
The pump is not running or only for a short time.	Thermal motor protection triggered by overheating of the pump set.	Check the fluid temperature. (⇒ Section 6.2.3.2, Page 28)
	Thermal motor protection triggered by dry running of the pump set.	Check the fill level. (⇒ Section 5.6, Page 21)
	Power failure	Check the electrical installation.
	Automatic switchgear not switching or not correctly switching	Clean the automatic switchgear and check its function. (⇒ Section 7.3, Page 32)

⁶⁾ Pump pressure must be released before attempting to remedy faults on parts which are subjected to pressure. Disconnect the pump from the power supply and let it cool down.

9 Related Documents

9.1 Exploded view and list of components

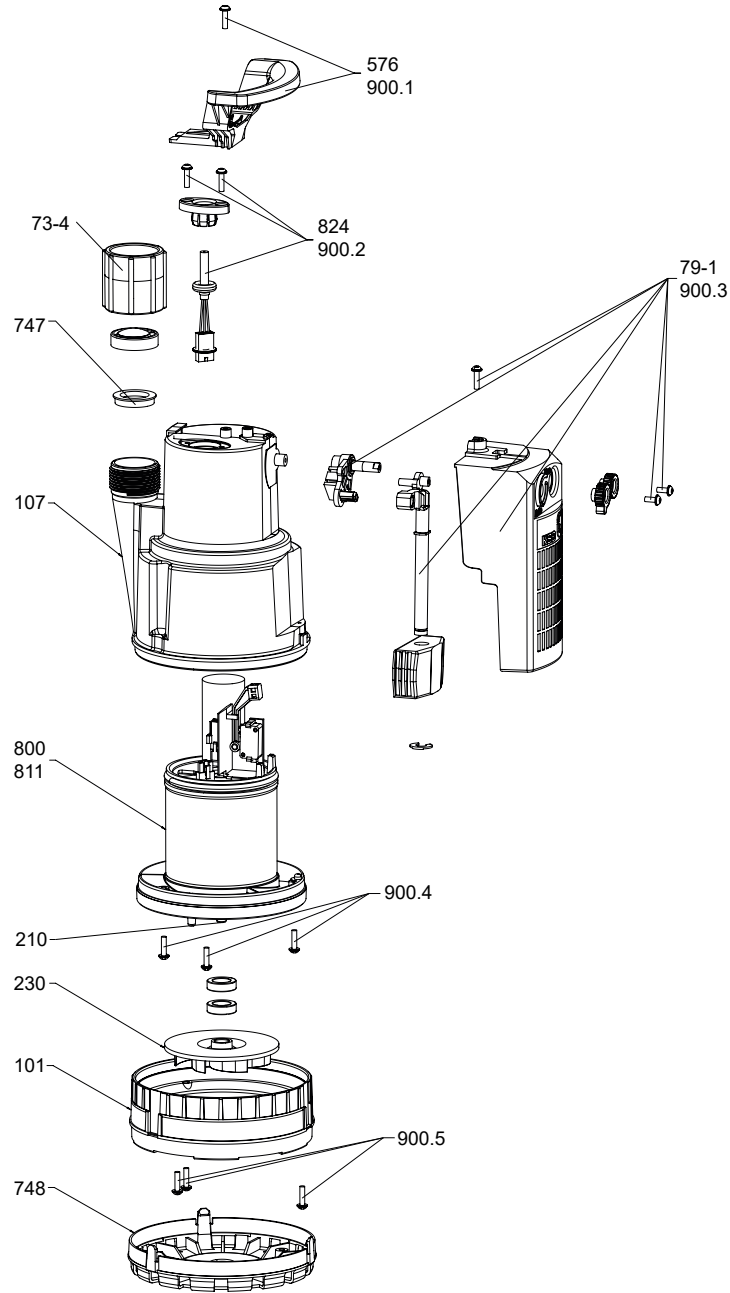

Fig. 28: Exploded view of AmaDrainer 301, 303

Table 12: List of components of AmaDrainer 301, 303

Part No.	Description	Part No.	Description
101	Pump casing	747	Swing check valve
107	Discharge casing	748	Suction strainer
210	Shaft	800	Motor
230	Impeller	811	Motor housing
576	Handle	824	Power cable
74-3	Connection socket	900.1/.2/.3/.4/.5	Bolt/screw
79-1	Automatic switchgear, external		

2332.8/05-EN

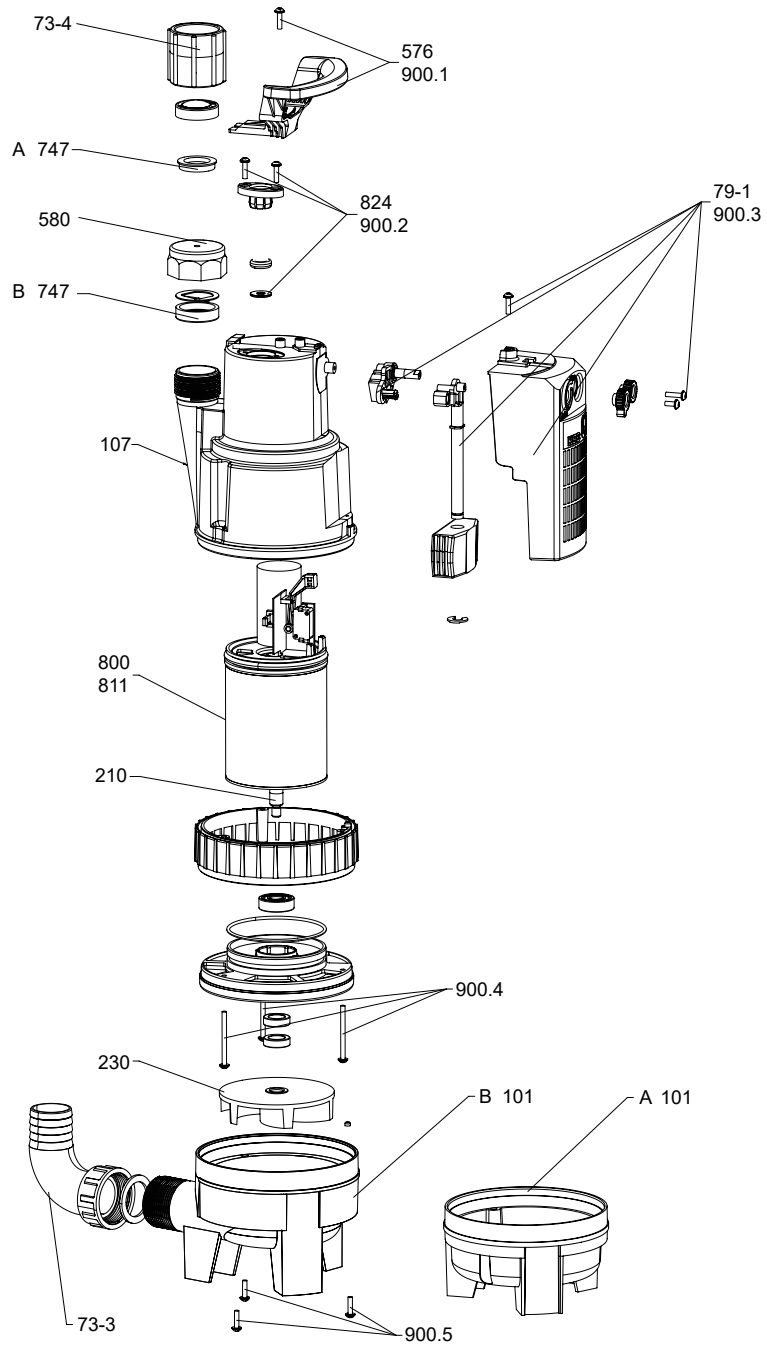

Fig. 29: Exploded view of AmaDrainer 322, 354

A	AmaDrainer 322	B	AmaDrainer 354
---	----------------	---	----------------

Table 13: List of components of AmaDrainer 322, 354

Part No.	Description	Part No.	Description
101	Pump casing	74-3	Connection socket
107	Discharge casing	79-1	Automatic switchgear, external
210	Shaft	747	Swing check valve ⁷⁾
230	Impeller	800	Motor
576	Handle	811	Motor housing

⁷⁾ On AmaDrainer 354 the swing check valve is mounted upside down (opening downwards) to enable venting of the pump casing.

Part No.	Description	Part No.	Description
580	Cap	824	Power cable
73-3	Hose connection (90° bend)	900.1/.2/.3/.4/.5	Bolt/screw

10 EU Declaration of Conformity

Manufacturer: **KSB S.A.S.**
128, rue Carnot,
59320 Sequedin (France)

The manufacturer herewith declares that the product:

AmaDrainer 3

Serial number: 2021w01 to 2023w52

- is in conformity with the provisions of the following directives / regulations as amended from time to time:
 - Pump set: 2006/42/EC Machinery Directive
 - Electrical components⁸⁾: 2011/65/EU Restriction of the use of certain hazardous substances in electrical and electronic equipment (RoHS)
 - 2014/30/EU: Electromagnetic Compatibility (EMC)

The manufacturer also declares that

- the following harmonised international standards have been applied:
 - ISO 12100
 - EN 809
 - EN 60034-1, EN 60034-5/A1
 - EN 60335-1/A1, EN 60335-2-41

Person authorised to compile the technical file:

Dr. Frank Obermair
Model-based Product Development
KSB SE & Co. KGaA
Johann-Klein-Straße 9
67227 Frankenthal (Germany)

The EU Declaration of Conformity was issued in/on:

Frankenthal, 1 June 2020



Jochen Schaab
Head of Product Development Pump Systems & Drives
KSB SE & Co. KGaA
Johann-Klein-Straße 9
67227 Frankenthal (Germany)

⁸ Where applicable

11 Certificate of Decontamination

Type:
 Order number /
 Order item number⁹⁾:
 Delivery date:
 Application:
 Fluid handled⁹⁾:

Please tick where applicable⁹⁾:



Corrosive



Oxidising



Flammable



Explosive



Hazardous to health



Seriously hazardous to health



Toxic



Radioactive



Bio-hazardous



Safe

Reason for return⁹⁾:

Comments:

The product / accessories have been carefully drained, cleaned and decontaminated inside and outside prior to dispatch / placing at your disposal.

We herewith declare that this product is free from hazardous chemicals and biological and radioactive substances.

For mag-drive pumps, the inner rotor unit (impeller, casing cover, bearing ring carrier, plain bearing, inner rotor) has been removed from the pump and cleaned. In cases of containment shroud leakage, the outer rotor, bearing bracket lantern, leakage barrier and bearing bracket or intermediate piece have also been cleaned.

For canned motor pumps, the rotor and plain bearing have been removed from the pump for cleaning. In cases of leakage at the stator can, the stator space has been examined for fluid leakage; if fluid handled has penetrated the stator space, it has been removed.

- No special safety precautions are required for further handling.
- The following safety precautions are required for flushing fluids, fluid residues and disposal:

.....

We confirm that the above data and information are correct and complete and that dispatch is effected in accordance with the relevant legal provisions.

.....
 Place, date and signature

.....
 Address

.....
 Company stamp

2332.8/05-EN

⁹⁾ Required field

Index

A

Applications 8
Automation 14

B

Bearing assembly 11
Bearings 14

C

Certificate of Decontamination 47
Commissioning 27, 29

D

Design 14
Designation 13
Disposal 12
Drive 14

E

Event of damage 6

F

Faults
 Causes and remedies 42

I

Installation 14
Installation at site 17
Intended use 8

K

Key to safety symbols/markings 7

N

Name plate 13

O

Order number 6
Other applicable documents 6

P

Partly completed machinery 6
Preservation 11
Product description 13

R

Return to supplier 12
Returning to service 29

S

Safety 8
Safety awareness 9
Scope of supply 16
Shaft seal 14
Shutdown 29
Start-up 27
Storage 11

T

Transport 11

W

Warnings 7
Warranty claims 6



KSB S.A.S.

128, rue Carnot • 59320 Sequedin (France)

Tél. 09 69 39 29 79

www.ksb.com/fr-fr