

High-efficiency Heating Circulator

Calio Pro / Calio Pro Z

Installation/Operating Manual



CE

KSB 

Legal information/Copyright

Installation/Operating Manual Calio Pro / Calio Pro Z

Original operating manual

All rights reserved. The contents provided herein must neither be distributed, copied, reproduced, edited or processed for any other purpose, nor otherwise transmitted, published or made available to a third party without the manufacturer's express written consent.

Subject to technical modification without prior notice.

© KSB SE & Co. KGaA, Frankenthal 2023-04-18

Contents

	Glossary	5
1	General.....	6
	1.1 Principles	6
	1.2 Target group.....	6
	1.3 Other applicable documents.....	6
	1.4 Symbols	6
	1.5 Key to safety symbols/markings.....	7
2	Safety	8
	2.1 General.....	8
	2.2 Intended use	8
	2.2.1 Prevention of foreseeable misuse	8
	2.3 Personnel qualification and training.....	9
	2.4 Consequences and risks caused by non-compliance with this manual	9
	2.5 Safety awareness	9
	2.6 Safety information for the user/operator	9
	2.7 Safety information for maintenance, inspection and installation	10
	2.8 Unauthorised modes of operation	10
3	Transport/Storage/Disposal	11
	3.1 Checking the condition upon delivery	11
	3.2 Transport.....	11
	3.3 Storage/preservation	12
	3.4 Return to supplier.....	13
	3.5 Disposal	13
4	Description.....	15
	4.1 General description	15
	4.2 Product information as per Regulation No. 1907/2006 (REACH).....	15
	4.3 Designation.....	15
	4.4 Name plate.....	16
	4.5 Design details.....	17
	4.6 Configuration and function.....	19
	4.7 Noise characteristics	20
	4.8 Scope of supply.....	20
	4.9 Dimensions and weight.....	20
	4.10 Accessories	20
5	Installation at Site	21
	5.1 Safety regulations.....	21
	5.2 Checks to be carried out prior to installation.....	21
	5.3 Installing the pump set	22
	5.4 Connecting the piping	26
	5.5 Fitting the enclosure/insulation.....	27
	5.6 Electrical connection	28
	5.6.1 Connecting the power cable	29
	5.6.2 Connecting dual-pump configurations.....	30
	5.6.3 Connecting the general fault message.....	32
6	Commissioning/Start-up/Shutdown.....	34
	6.1 Commissioning/Start-up	34
	6.1.1 Prerequisites for commissioning/start-up	34
	6.1.2 Priming and venting the pump.....	34
	6.1.3 Commissioning / Start-up	36
	6.2 Operating limits.....	37
	6.2.1 Frequency of starts.....	37

6.2.2	Ambient temperature.....	37
6.2.3	Minimum inlet pressure.....	37
6.2.4	Maximum operating pressure	38
6.2.5	Fluid handled	38
6.3	Shutdown.....	39
6.3.1	Shutdown	39
6.3.2	Measures to be taken for shutdown.....	39
6.4	Returning to service	40
7	Operation.....	41
7.1	Control panel.....	41
7.1.1	Display	42
7.2	Operating modes.....	43
7.2.1	Information on settings.....	43
7.2.2	Constant-pressure Control.....	44
7.2.3	Proportional-pressure Control.....	45
7.2.4	Dynamic Control	47
7.2.5	Open-loop control	49
7.3	Functions.....	50
7.3.1	Dual-pump operation (DUAL)	50
7.3.2	Protective functions	51
7.3.3	Saving data.....	51
7.3.4	Error messages	51
7.4	Additional functions.....	54
7.4.1	Locking / unlocking the control panel.....	54
7.4.2	Venting.....	55
7.4.3	Test alert.....	56
7.4.4	Information	57
7.5	Resetting to factory settings.....	57
8	Servicing/Maintenance	58
8.1	Servicing/inspection.....	58
8.2	Drainage/cleaning	58
8.3	Removing the pump set from the piping	58
8.3.1	Removing the power cable	60
9	Trouble-shooting.....	61
10	Related Documents	62
10.1	Sectional drawing with list of components.....	62
11	EU Declaration of Conformity	63
	Index	64

Glossary

Discharge line

The pipeline which is connected to the discharge nozzle

Pump set

Complete pump set consisting of pump, drive, additional components and accessories

Suction lift line/suction head line

The pipeline which is connected to the suction nozzle

1 General

1.1 Principles

This operating manual is valid for the type series and variants indicated on the front cover.

The operating manual describes the proper and safe use of this equipment in all phases of operation.

The name plate indicates the type series and size as well as the main operating data. They uniquely identify the pump (set) and serve as identification for all further business processes.

In the event of damage, immediately contact your nearest KSB service facility to maintain the right to claim under warranty.

1.2 Target group

This operating manual is aimed at the target group of trained and qualified specialist technical personnel. (⇒ Section 2.3, Page 9)

1.3 Other applicable documents

Table 1: Overview of other applicable documents

Document	Contents
Data sheet	Description of the technical data of the pump (set)

For accessories and/or integrated machinery components, observe the relevant manufacturer's product literature.









1.4 Symbols

Table 2: Symbols used in this manual

Symbol	Description
✓	Conditions which need to be fulfilled before proceeding with the step-by-step instructions
▷	Safety instructions
⇒	Result of an action
⇔	Cross-references
1. 2.	Step-by-step instructions
	Note Recommendations and important information on how to handle the product

1.5 Key to safety symbols/markings

Table 3: Definition of safety symbols/markings

Symbol	Description
	DANGER This signal word indicates a high-risk hazard which, if not avoided, will result in death or serious injury.
	WARNING This signal word indicates a medium-risk hazard which, if not avoided, could result in death or serious injury.
	CAUTION This signal word indicates a hazard which, if not avoided, could result in damage to the machine and its functions.
	General hazard In conjunction with one of the signal words this symbol indicates a hazard which will or could result in death or serious injury.
	Electrical hazard In conjunction with one of the signal words this symbol indicates a hazard involving electrical voltage and identifies information about protection against electrical voltage.
	Machine damage In conjunction with the signal word CAUTION this symbol indicates a hazard for the machine and its functions.
	Warning: Strong magnetic field In conjunction with one of the signal words this symbol indicates a hazard involving magnetic fields and identifies information about protection against magnetic fields.
	Warning for persons with pacemaker In conjunction with one of the signal words this symbol indicates a hazard involving magnetic fields and identifies special information for persons with a pacemaker.
	Warning about hot surfaces In conjunction with one of the signal words this symbol indicates a hazard involving hot surfaces.



2 Safety

All the information contained in this section refers to hazardous situations.

In addition to the present general safety information the action-related safety information given in the other sections must be observed.

2.1 General

- This operating manual contains general installation, operating and maintenance instructions that must be observed to ensure safe operation of the system and prevent personal injury and damage to property.
- Comply with all the safety instructions given in the individual sections of this operating manual.
- The operating manual must be read and understood by the responsible specialist personnel/operators prior to installation and commissioning.
- The contents of this operating manual must be available to the specialist personnel at the site at all times.
- Information and markings attached directly to the product must always be complied with and kept in a perfectly legible condition at all times. This applies to, for example:
 - Flow direction arrow
 - Markings for connections
 - Name plate
- The operator is responsible for ensuring compliance with all local regulations not taken into account.

2.2 Intended use

- The pump (set) must only be operated in the fields of application and within the use limits specified in the other applicable documents.
- Only operate pumps/pump sets which are in perfect technical condition.
- Do not operate the pump (set) in partially assembled condition.
- Only use the pump to handle the fluids described in the data sheet or product literature of the pump model or variant.
- Never operate the pump without the fluid to be handled.
- Observe the minimum flow rate and maximum flow rate indicated in the data sheet or product literature (e.g. to prevent overheating, cavitation damage, bearing damage).
- Do not throttle the flow rate on the suction side of the pump (to prevent cavitation damage).
- Consult the manufacturer about any use or mode of operation not described in the data sheet or product literature.

2.2.1 Prevention of foreseeable misuse

- Observe all safety information and instructions in this manual.
- Never exceed the permissible application and operating limits specified in the data sheet or product literature regarding pressure, temperature, etc.

2.3 Personnel qualification and training

All personnel involved must be fully qualified to transport, install, operate, maintain and inspect the equipment this manual refers to.

The responsibilities, competence and supervision of all personnel involved in transport, installation, operation, maintenance and inspection must be clearly defined by the operator.

Deficits in knowledge must be rectified by means of training and instruction provided by sufficiently trained specialist personnel. If required, the operator can commission the manufacturer/supplier to train the personnel.

Training on the pump (set) must always be supervised by technical specialist personnel.

This device may be operated by **children** from the age of 8 as well as by persons of limited physical, sensory or mental abilities or lacking experience and knowledge, provided that they are supervised, they have been instructed on how to use this device safely and they understand the hazards it presents. It is impermissible for **children** to play with this device. **Children** must not clean the device or perform any **service work to be carried out by the operator** at the device without supervision.

2.4 Consequences and risks caused by non-compliance with this manual

- Non-compliance with these operating instructions will lead to forfeiture of warranty cover and of any and all rights to claims for damages.
- Non-compliance can, for example, have the following consequences:
 - Hazards to persons due to electrical, thermal, mechanical and chemical effects and explosions
 - Failure of important product functions
 - Failure of prescribed maintenance and servicing practices
 - Hazard to the environment due to leakage of hazardous substances

2.5 Safety awareness

In addition to the safety information contained in this operating manual and the intended use, the following safety regulations shall be complied with:

- Accident prevention, health regulations and safety regulations
- Explosion protection regulations
- Safety regulations for handling hazardous substances
- Applicable standards, directives and laws

2.6 Safety information for the user/operator

- Fit protective equipment (e.g. contact guards) supplied by the operator for hot, cold or moving parts, and check that the equipment functions properly.
- Do not remove any protective equipment (e.g. contact guards) during operation.
- Provide the personnel with protective equipment and make sure it is used.
- Contain leakages (e.g. at the shaft seal) of hazardous fluids handled (e.g. explosive, toxic, hot) so as to avoid any danger to persons and the environment. Adhere to all relevant laws.
- Eliminate all electrical hazards. (In this respect refer to the applicable national safety regulations and/or regulations issued by the local energy supply companies.)
- If stopping the pump does not increase potential risk, fit an emergency-stop control device in the immediate vicinity of the pump (set) during pump set installation.

2.7 Safety information for maintenance, inspection and installation

- Modifications or alterations of the pump (set) are only permitted with the manufacturer's prior consent.
- Use only original spare parts or parts/components authorised by the manufacturer. The use of other parts/components can invalidate any liability of the manufacturer for resulting damage.
- The operator ensures that maintenance, inspection and installation are performed by authorised, qualified specialist personnel who are thoroughly familiar with the manual.
- Only carry out work on the pump (set) during standstill of the pump.
- Only perform work on the pump set when it has been disconnected from the power supply (de-energised).
- The pump (set) must have cooled down to ambient temperature.
- Pump pressure must have been released and the pump must have been drained.
- When taking the pump set out of service always adhere to the procedure described in the manual. (⇒ Section 6.3.2, Page 39)
- Decontaminate pumps which handle fluids posing a health hazard.
- As soon as the work has been completed, re-install and re-activate any safety-relevant devices and protective devices. Before returning the product to service, observe all instructions on commissioning. (⇒ Section 6.1, Page 34)

2.8 Unauthorised modes of operation

Never operate the pump (set) outside the limits stated in the data sheet and in this operating manual.

The warranty relating to the operating reliability and safety of the pump (set) supplied is only valid if the equipment is used in accordance with its intended use.

3 Transport/Storage/Disposal

3.1 Checking the condition upon delivery

1. On transfer of goods, check each packaging unit for damage.
2. In the event of in-transit damage, assess the exact damage, document it and notify KSB or the supplying dealer and the insurer about the damage in writing immediately.

3.2 Transport

	⚠ DANGER
	<p>The pump (set) could slip out of the suspension arrangement. Danger to life from falling parts!</p> <ul style="list-style-type: none"> ▷ Always transport the pump (set) in the specified position. ▷ The lifting accessories must be tight and without slack. ▷ Observe the information on weights, centre of gravity and fastening points. ▷ Observe the applicable local occupational safety regulations and accident prevention regulations. ▷ Use tested and approved lifting accessories.
	⚠ WARNING
	<p>Insufficient stability Risk of crushing hands and feet!</p> <ul style="list-style-type: none"> ▷ During assembly/dismantling, secure the pump (set)/pump parts to prevent tilting or tipping over.

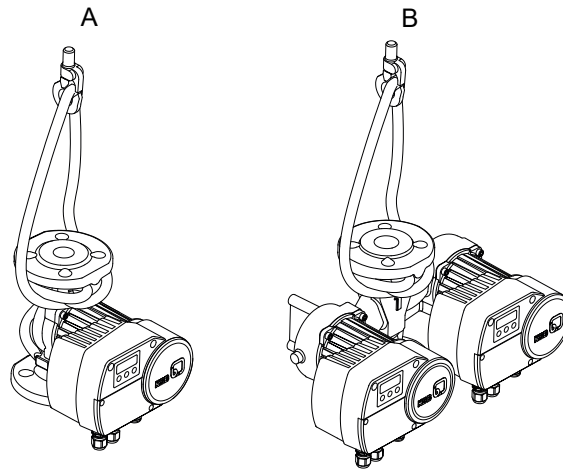

Fig. 1: Transporting the pump set

A Single pump	B Twin pump
---------------	-------------

- ✓ Transport equipment / lifting equipment suitable for the corresponding weight (see type series booklet) has been selected and is on hand.
1. To transport the pump set suspend it from the lifting tackle as shown.
 2. Carefully place down the pump set at the place of installation. Protect it against damage and secure it against rolling off.

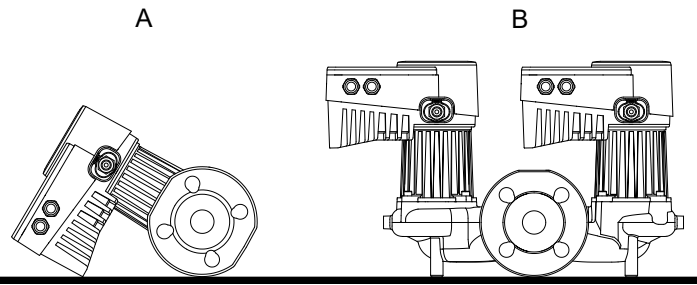

Fig. 2: Placing the pump set down

A	Single pump	B	Twin pump
---	-------------	---	-----------

3.3 Storage/preservation

	CAUTION
	<p>Damage during storage due to humidity, dirt or vermin Corrosion/contamination of pump (set)!</p> <ul style="list-style-type: none"> ▸ For outdoor storage cover the pump (set) and accessories with waterproof material and protect against condensation.
	CAUTION
	<p>Wet, contaminated or damaged openings and connections Leakage or damage to the pump!</p> <ul style="list-style-type: none"> ▸ Clean and cover pump openings and connections as required prior to putting the pump into storage.

If commissioning is to take place some time after delivery, we recommend that the following measures be taken for pump (set) storage.

- Store the pump (set) in a dry, protected room where the atmospheric humidity is as constant as possible.

If properly stored indoors, the equipment is protected for a maximum of 12 months. New pumps/pump sets are supplied by our factory duly prepared for storage.

For storing a pump (set) which has already been operated, observe the instructions in (⇒ Section 6.3.2, Page 39) .

Table 4: Ambient conditions for storage

Ambient condition	Value
Relative humidity	80 % maximum
Ambient temperature	0 °C to + 40 °C

- Well-ventilated
- Dry
- Dust-free
- Shock-free
- Vibration-free

3.4 Return to supplier

1. Drain the pump as per operating instructions.
2. Always flush and clean the pump, particularly if it has been used for handling noxious, hot or other hazardous fluids.
3. If the fluids handled by the pump (set) leave residues which might lead to corrosion when coming into contact with atmospheric humidity, or which might ignite when coming into contact with oxygen, the pump set must be neutralised, and anhydrous inert gas must be blown through the pump for drying purposes.
4. Always complete and enclose a certificate of decontamination when returning the pump (set).
Always indicate any safety and decontamination measures taken.

	NOTE
	<p>If required, a blank certificate of decontamination can be downloaded from the following web site: www.ksb.com/certificate_of_decontamination</p>

3.5 Disposal

	! DANGER
	<p>Strong magnetic field in the pump rotor area Danger of death for persons with pacemaker! Interference with magnetic data carriers, electronic devices, components and instruments! Uncontrolled magnetic attraction forces between magnet-equipped components, tools or similar!</p> <ul style="list-style-type: none"> ▸ Keep a safety distance of at least 0.3 m.

	! WARNING
	<p>Fluids handled, consumables and supplies which are hot and/or pose a health hazard Hazard to persons and the environment!</p> <ul style="list-style-type: none"> ▸ Collect and properly dispose of flushing fluid and any fluid residues. ▸ Wear safety clothing and a protective mask if required. ▸ Observe all legal regulations on the disposal of fluids posing a health hazard.

1. Dismantle the pump (set).
Collect greases and other lubricants during dismantling.
2. Separate and sort the pump materials, e.g. by:
 - Metals
 - Plastics
 - Electronic waste
 - Greases and other lubricants
3. Dispose of materials in accordance with local regulations or in another controlled manner.



Electrical or electronic equipment marked with the adjacent symbol must not be disposed of in household waste at the end of its service life.

Contact your local waste disposal partner for returns.

If the used electrical or electronic equipment contains personal data, the operator is responsible for deleting it before the equipment is returned.

4 Description

4.1 General description

- High-efficiency heating circulator with continuously variable speed control
- Non-self-priming in-line pump with integrated permanent magnet synchronous motor and electronic variable speed system
- Pump for handling clean, non-aggressive fluids which are not chemically and mechanically aggressive to the pump materials

4.2 Product information as per Regulation No. 1907/2006 (REACH)

For information as per European chemicals regulation (EC) No. 1907/2006 (REACH) see <https://www.ksb.com/en-global/company/corporate-responsibility/reach>.

4.3 Designation

Example: Calio Pro 25-40

Table 5: Designation key

Code	Description	
Calio Pro	Type series	
	- ¹⁾	Single pump
	Z	Twin pump
25	Connection	
	25	G 1 1/2
	30	G 2
	32	DN 32
	40	DN 40
	50	DN 50
	65	DN 65
40	Head H ²⁾ [m]	
	40	Head × 10 Example: 4 m × 10 = 40

¹ Blank

² At flow rate Q = 0 m³/h

4.4 Name plate

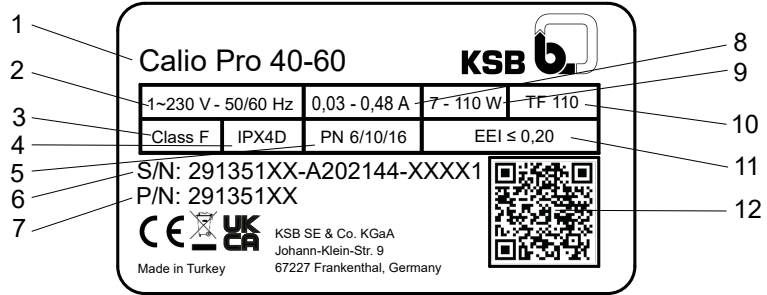

Fig. 3: Name plate (example)

1	Type series, size	7	Material number
2	Supply voltage, frequency	8	Current input
3	Thermal class	9	Power input
4	Enclosure	10	Temperature class
5	Pressure class	11	Energy efficiency index EEI
6	Production number	12	QR code

Key to the production number

Example: 291351XX-A202144-XXXX1

Table 6: Key to the production number

Code	Description
291351XX	Material number
2021	Year of production
44	Week of production
XXXX1	Consecutive number

4.5 Design details

Design

- Maintenance-free high-efficiency wet rotor pump (glandless)

Drive

- High-efficiency permanent magnet synchronous motor, brushless, self-cooling, with continuously variable differential pressure control
- 1~230 V AC +/- 10%
- Frequency 50 Hz/60 Hz
- Enclosure IPX4D
- Thermal class F
- Temperature class TF 110
- Energy efficiency index $EEI \leq 0.20^3)$
- Interference emissions EN 55014-1, EN 61000-3-2, EN 61000-3-3
- Interference immunity EN 55014-2

Bearings

- Product-lubricated special plain bearing

Connections

- Screw-ended or flanged

Operating modes

- Constant-pressure control
- Proportional-pressure control
- Dynamic Control
- Open-loop control with 3 speed levels

Automatic functions

- Continuously variable speed adjustment depending on the mode of operation
- Dual-pump operation
- Deblocking function
- Self-venting function of the pump casing
- Soft start
- Full motor protection with integrated trip electronics

Manual functions

- Setting the operating mode
- Setting the discharge head setpoint
- Setting the speed level
- Rotor space venting function
- Vent plug⁴⁾
- Locking the control panel

³ Calio Pro Z 30-100: $EEI = 0.21$

⁴ For twin pumps

Signalling functions and display functions

- Display of the set head
- Display of the speed level
- Display of the pump set status (running / not running)
- Error codes indicated on the display
- General fault message (volt-free changeover contact)

4.6 Configuration and function

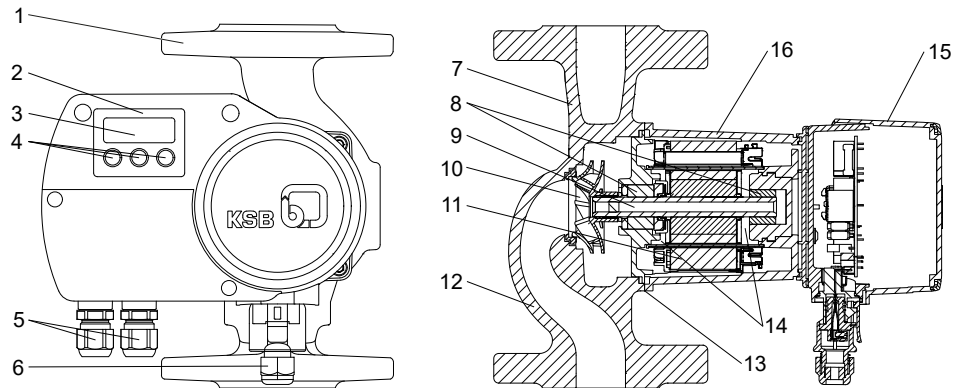

Fig. 4: Illustration of the pump set

1	Pump casing	9	Pump rotor
2	Control panel	10	Impeller
3	Display	11	Stator
4	Control element (3 control buttons)	12	Suction nozzle
5	Connection for general fault message and dual-pump operation (DUAL)	13	Condensate opening
6	Plug-type connector for power supply	14	Rotor space
7	Discharge nozzle	15	Electronic system housing
8	Radial plain bearing	16	Motor housing

Design The pump is designed with a radial fluid inlet (suction nozzle) and a radial fluid outlet (discharge nozzle) arranged on the same axis. The impeller is rigidly connected to the motor shaft. Mechanical sealing is not required as the rotating assembly is completely isolated from the stator winding. The rotating assembly is lubricated and cooled by the fluid handled. The electronic system housing is equipped with a plug-type connector. Depending on the design, the pump set is fitted with high-quality ceramic bearings or carbon bearings, ensuring smooth running and a long service life. The integrated continuously variable differential pressure control and electronic control unit enable an optimum adjustment of the pump to changing operating conditions and minimise operating costs. The combination of the hydraulic system with a high-efficiency electric motor makes sure that the input power is converted into hydraulic energy as efficiently as possible.

Function The fluid enters the pump via the suction nozzle (12) and is accelerated outward in a cylindrical flow by the rotating impeller (10). In the flow passage of the pump casing the kinetic energy of the fluid is converted into pressure. The fluid is pumped to the discharge nozzle (7), where it leaves the pump. The pump rotor (9) runs in radial plain bearings (8). The radial plain bearings (8) are supported by the stator (11).

4.7 Noise characteristics

Average sound pressure level ≤ 40 dB (A)

4.8 Scope of supply

Depending on the model, the following items are included in the scope of supply:

- Pump set
- Sealing elements
- Plug-type connector to power supply
- Installation/operating manual

Single pump:

- Two-piece thermal insulation shell (single pump)

Twin pump:

- Pre-configured dual connection cable
- Vent plug

4.9 Dimensions and weight



For dimensions and weights please refer to the type series booklet of the pump (set).

4.10 Accessories

- Pipe unions
- Spacers

5 Installation at Site

5.1 Safety regulations







	<p style="background-color: #e67e22; color: white; padding: 2px;">⚠ DANGER</p> <p>Installation in potentially explosive atmospheres Explosion hazard!</p> <ul style="list-style-type: none"> ▷ Never install the pump in potentially explosive atmospheres. ▷ Observe the information given in the data sheet and on the name plates of the pump system.
	<p style="background-color: #e67e22; color: white; padding: 2px;">⚠ DANGER</p> <p>Use for drinking water or foodstuff applications Danger of poisoning!</p> <ul style="list-style-type: none"> ▷ Never use the pump for drinking water or foodstuff applications.
	<p style="background-color: #f1c40f; padding: 2px;">CAUTION</p> <p>Improper installation of the pump set Damage to the pump set!</p> <ul style="list-style-type: none"> ▷ Observe the permissible ambient conditions and the pump set's type of enclosure. ▷ Observe the permissible ambient temperatures. Ambient temperatures < 0 °C are not permitted. ▷ In the event of outdoor installation, fit a protective roof to protect the pump set from the weather (e. g. sun, rain, snow).

5.2 Checks to be carried out prior to installation

Before beginning with the installation check the following:

- All structural work required has been checked and prepared in accordance with the dimensions in the outline drawing.
- The data on the name plate of the pump set has been checked. The pump set must be suitable for operation on the available power supply network.
(⇒ Section 4.4, Page 16)
- The fluid to be handled matches the description of suitable fluids.
(⇒ Section 6.2.5.1, Page 38)

5.3 Installing the pump set

	<p>! DANGER</p> <p>Leakage at the pump Leakage of hot fluids!</p> <ul style="list-style-type: none"> ▷ Fit the sealing elements and make sure they are positioned correctly.
	<p>CAUTION</p> <p>Fluid entering the electronic system housing Damage to the pump set!</p> <ul style="list-style-type: none"> ▷ Install the pump set with the pump shaft in horizontal position. Connect the piping without transmitting any stresses and strains. ▷ Never install the pump set with the electronic system housing pointing upwards or downwards. ▷ Undo the hexagon socket head cap screws. Then turn the electronic system housing.
	<p>CAUTION</p> <p>Air entering the pump Damage to vertically installed pump sets whose direction of flow is downwards!</p> <ul style="list-style-type: none"> ▷ Fit a vent valve at the highest point of the suction line.
	<p>NOTE</p> <p>Installing shut-off valves upstream and downstream of the pump set is recommended. Make sure that no leakage drips onto the pump set.</p>
	<p>NOTE</p> <p>The direction of flow of a vertically installed pump should be upwards.</p>
	<p>NOTE</p> <p>Do not install the pump at the lowest point of the system to prevent any impurities from collecting in the pump.</p>

Permissible installation positions

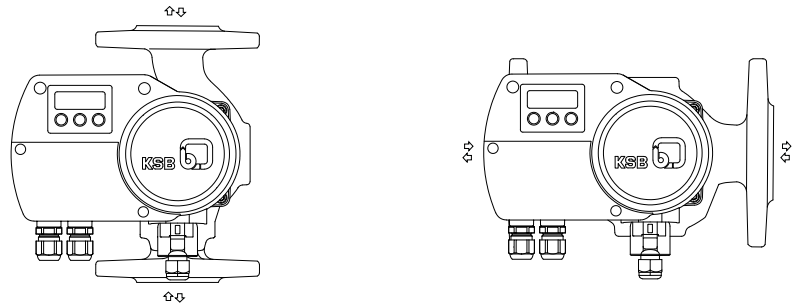

Fig. 5: Permissible installation positions (single pump)

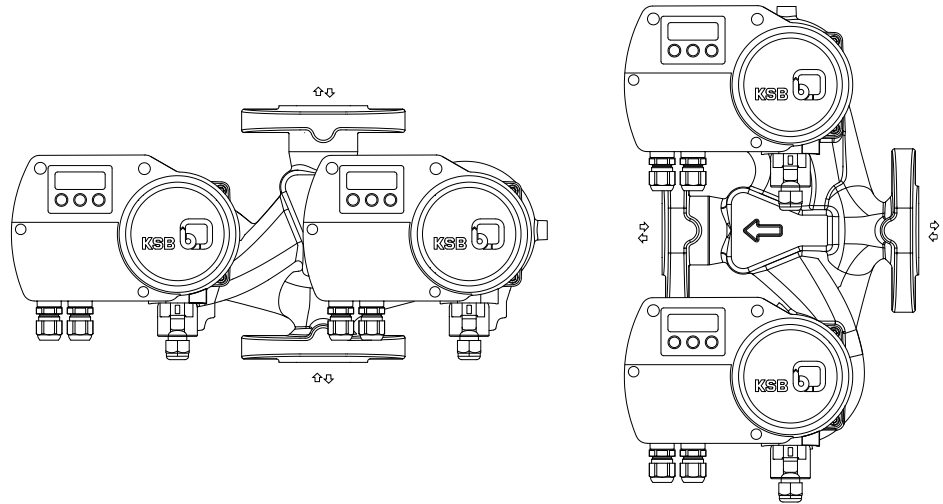

Fig. 6: Permissible installation positions (twin pump)

Turning the electronic system housing (optional)

The electronic system housing with integrated control unit can be turned. The display must always be in a readable position. Positioning must be carried out with the pump set removed from the system.

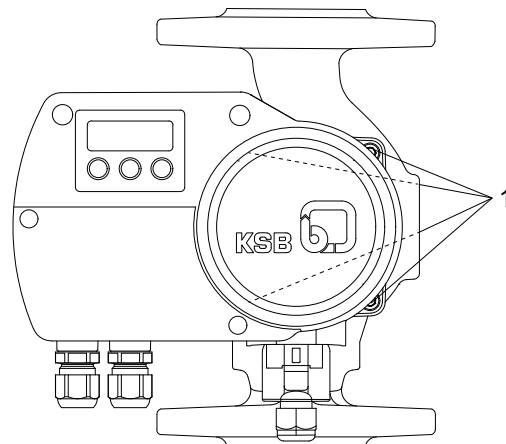

Fig. 7: Turning the electronic system housing

1. Undo four hexagon socket head cap screws (1) between the motor housing and pump casing and store them.
2. Turn the electronic system housing until it has reached the required position. Compare it against the permissible installation positions. Adjust the position if required.
3. Tighten four hexagon socket head cap screws (1) with a suitable tool. Tightening torque = 9 Nm

- Screw-ended pump**
1. Position the pump set as indicated in an easily accessible place.
 - ⇒ An arrow on the pump casing and thermal insulation shell indicates the direction of flow.
 2. Accurately insert the sealing element.
 3. Connect the pump and piping with a pipe union.
 4. Tighten the pipe union hand-tight with a suitable tool.
 5. Accurately insert the sealing element in the opposite pipe union.
 6. Tighten the pipe union hand-tight with a suitable tool.

- Flanged pump**
1. Position the pump set as indicated in an easily accessible place.
 - ⇒ An arrow on the pump casing and thermal insulation shell indicates the direction of flow.
 2. Accurately insert the sealing element.
 3. Place washers on the holes of the pump flange.
 4. Secure the pump flange to the pipe flange using bolts and washers. Observe the tightening torques.
 5. Accurately insert the sealing element on the opposite side.
 6. Bolt the pump flange to the pipe flange.
 7. Tighten the bolts with a suitable tool. Observe the tightening torques.

Table 7: Tightening torque depending on the pressure class

PN	Thread	Tightening torque
[bar]		[Nm]
6	M12	30
10/16	M16	70

Twin pump: Fitting the vent plug⁵⁾ for horizontal installation position

	NOTE
<p>In a vertical installation position the pump set is self-venting. In a horizontal installation position the upper pump set can be manually vented via a vent plug.</p>	

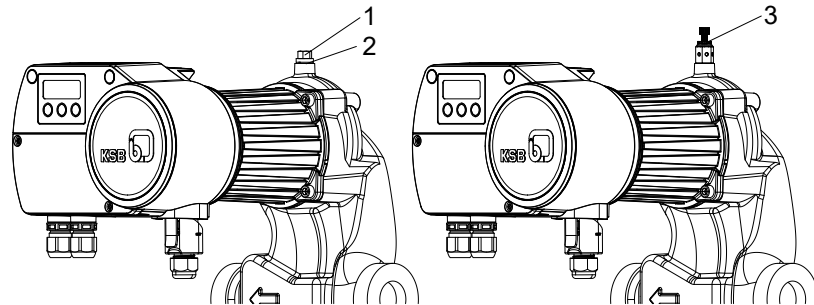





Fig. 8: Fitting the vent plug for horizontal installation position

1	Screw plug	3	Vent plug
2	Sealing element		

- ✓ The pump set has been fitted in a horizontal installation position.
- ✓ No fluid handled is in the pump set.
- 1. Remove and store the screw plug (1) and sealing element (2) of the upper pump set.
- 2. Seal the vent plug (3) with suitable means (e.g. thread-sealing tape).
- 3. Fit the sealed vent plug (3). Tightening torque = 10 Nm



⁵⁾ If applicable

5.4 Connecting the piping

	<p>WARNING</p> <p>Hot surface Risk of burns</p> <ul style="list-style-type: none"> ▸ Never touch a pump set when it is in operation.
	<p>WARNING</p> <p>Impermissible loads acting on the pump nozzles Risk of burns by hot fluids escaping!</p> <ul style="list-style-type: none"> ▸ Do not use the pump as an anchorage point for the piping. ▸ Anchor the pipes in close proximity to the pump and connect them without transmitting any stresses or strains. ▸ Take appropriate measures to compensate for thermal expansion of the piping.
	<p>CAUTION</p> <p>Contamination/dirt in the piping Damage to the pump!</p> <ul style="list-style-type: none"> ▸ Flush the piping prior to commissioning or replacing the pump. Remove any foreign matter.
	<p>NOTE</p> <p>Installing check and shut-off elements in the system is recommended, depending on the type of plant and pump. However, such elements must not obstruct proper drainage or hinder disassembly of the pump.</p>

- ✓ Suction lift lines have been laid with a rising slope, suction head lines with a downward slope towards the pump.
 - ✓ The nominal sizes of the piping are equal to or greater than the nominal sizes of the pump nozzles.
 - ✓ The piping has been anchored in close proximity to the pump and connected without transmitting any stresses or strains.
1. Thoroughly clean, flush and blow through all vessels, piping and connections (especially of new installations).

5.5 Fitting the enclosure/insulation

	<p>⚠ WARNING</p> <p>The pump takes on same temperature as the fluid handled Risk of burns! ▷ Insulate the pump casing. Fit protective equipment.</p>
	<p>CAUTION</p> <p>Heat build-up at motor housing and electronic system housing Pump overheating! ▷ Do not insulate the motor housing and electronic system housing.</p>

Heating application

- ✓ The supplied thermal insulation shell is available.
- 1. Fit the supplied thermal insulation shell to the pump casing.

Cooling application

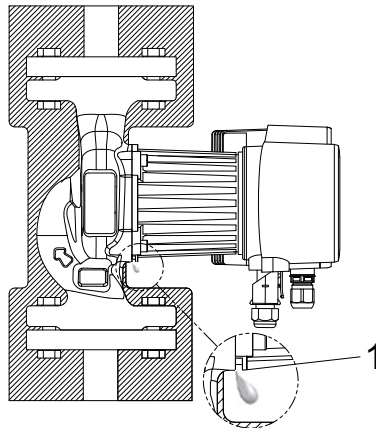







Fig. 9: Condensate opening

- 1. Insulate the pump casing with suitable means. The condensate opening (1) at the bottom of the motor housing has to be unobstructed.

5.6 Electrical connection

	<p>⚠ DANGER</p> <p>Electrical connection work by unqualified personnel Danger of death from electric shock!</p> <ul style="list-style-type: none"> ▷ Always have the electrical connections installed by a trained and qualified electrician. ▷ Observe the EN 61557 regulations as well as any regional regulations.
	<p>⚠ DANGER</p> <p>Work performed on an energised plug-type connector Danger of death from electric shock!</p> <ul style="list-style-type: none"> ▷ Switch off the supply voltage at least 5 minutes prior to commencing work and ensure that it cannot be switched on again unintentionally.
	<p>⚠ DANGER</p> <p>Pump acting as a generator when running in reverse Danger to life from hazardous induction voltage at the motor terminals!</p> <ul style="list-style-type: none"> ▷ Prevent the fluid from flowing back by closing the shut-off elements.
	<p>⚠ DANGER</p> <p>Heat damage to the cable sheath Danger from electric shock!</p> <ul style="list-style-type: none"> ▷ Make sure the cables are never laid in contact with hot casings/housings or pipelines.
	<p>⚠ DANGER</p> <p>Open terminal wiring compartment Danger of death from electric shock!</p> <ul style="list-style-type: none"> ▷ Prior to removing the cover of the terminal wiring compartment, switch off the supply voltage and ensure that it cannot be switched on again unintentionally. ▷ Only open the cover of the terminal wiring compartment to connect / disconnect the general fault message relay and/or the dual connection cable. ▷ If applicable, switch off the external power supply to message relays and control cables and make sure it cannot be switched on again unintentionally. ▷ Keep the covers of the terminal wiring compartments closed during operation as well as during maintenance work.

	⚠ DANGER
	<p>Incorrect connection to the mains Danger to life from electric shock!</p> <ul style="list-style-type: none"> ▷ Observe the technical specifications of the local energy supply companies. ▷ The core cross-section has to be at least $3 \times 0.75 \text{ mm}^2$. ▷ Use a slow acting C-type circuit breaker with a nominal current of at least $1.4 \times$ the nominal current of the pump set. For the nominal current see name plate. ▷ The power cable has to be fitted with an all-pole isolating switch with a minimum contact opening of 3 mm. A shockproof plug must not be used. ▷ If the power cable for the device is damaged, have it replaced by the manufacturer, a customer service technician or a similarly qualified person. See EN 60335-1.
	NOTE
	<p>Using a permanently installed power cable of type H05VV-F 3G1.5 or similar is recommended.</p>

Residual current device Using a universal AC/DC sensitive residual current device to DIN VDE 0160 is recommended. Conventional residual current devices might either fail to trip or trip erroneously.
 Discharge current per pump < 3.5 mA

5.6.1 Connecting the power cable

Table 8: Power cable dimensions

Power cable dimensions	Values
Outside diameter	5,5 - 8,0 mm
Cross-section	0,75 - 1,5 mm ² (solid or stranded ⁶)

1. Verify the supply voltage at the site against the data on the name plate.
2. Switch off the power supply and make sure it cannot be switched on again unintentionally.
3. Fit the union nut and joint ring on the power cable.
4. Guide the power cable through the plug housing until the cable ends are freely accessible.
5. Strip the power cable as shown in the illustration.
 Strip about 18 mm of the earth conductor sheath. Strip about 13 mm of the neutral conductor sheath and L conductor sheath.
 Strip 6 mm of each core's sheath as a minimum.

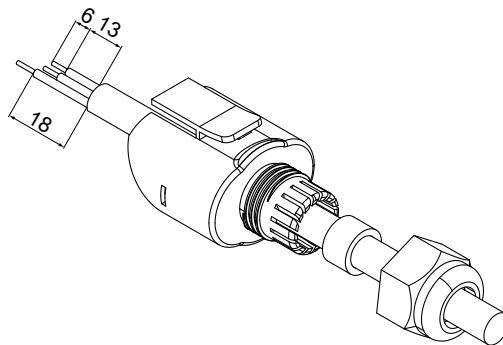

Fig. 10: Stripping the power cable [mm]

6. Connect the cores at the contact insert.

⁶ Fit wire end sleeves on stranded / flexible electric cables.

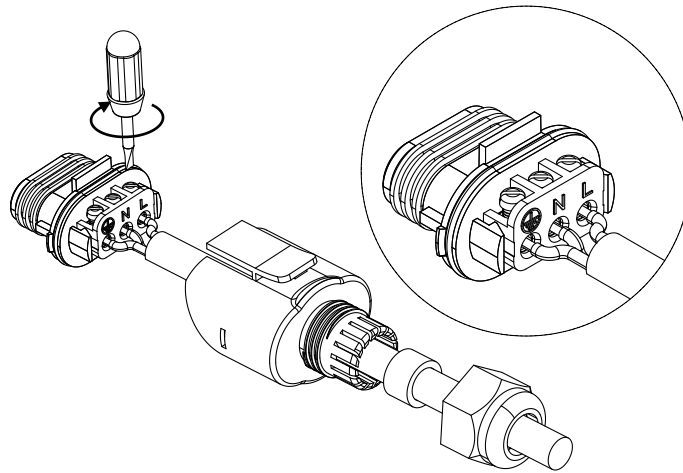

Fig. 11: Connecting the cores at the contact insert

L	Conductor / phase (230 V)
N	Neutral conductor
⏚	Earth conductor

- Slide the contact insert into the plug housing until you can hear it engage. Make sure the projection is positioned correctly.

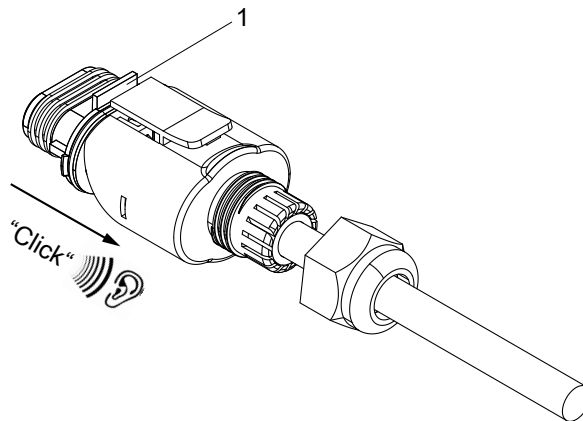

Fig. 12: Fastening the contact insert to the plug housing

1	Projection
---	------------

- Screw the union nut and joint ring onto the thread at the plug housing. Tightening torque = 1 Nm
- Connect the plug-type connector at the pump set.

5.6.2 Connecting dual-pump configurations

Table 9: Symbols key

Function	Symbol	Terminal pair	Maximum terminal cross-section	Terminal code	Contact rating
Dual-pump configuration	DUAL		1,5 mm ²	H = Signal High (+) L = Signal Low (-) GND = 0 V	-

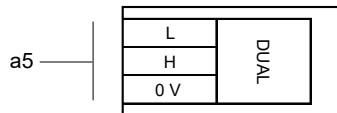

Fig. 13: Terminal wiring diagram for dual-pump configuration

a	Data line connections
a5	Dual-pump configuration

- ✓ The dual connection cable⁷⁾ (impedance 120 Ω, 3-core, shielded) with shield clamp⁷⁾ and screw⁷⁾ 3.5 × 6.5 is available.
- 1. Switch off the power supply and make sure it cannot be switched on again unintentionally.
- 2. Undo the screws (1) at the cover of the terminal wiring compartment at the electronic system housing with a suitable tool.

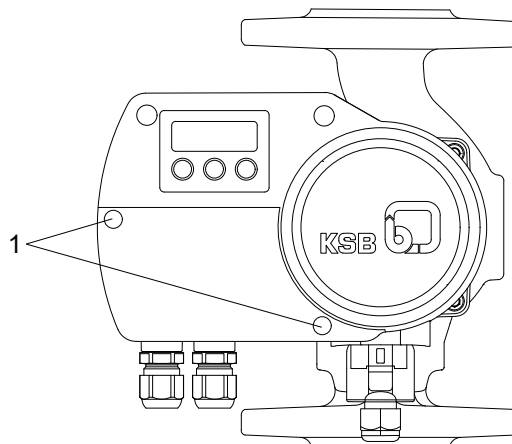

Fig. 14: Removing the cover of the terminal wiring compartment

- 3. Prepare the cable gland that belongs to the DUAL terminal pair.
- 4. Guide the dual connection cable through the cable gland and into the connection space.
- 5. Screw the union nut and joint ring on hand-tight.
- 6. Clamp the shield clamp (2) onto the shield of the dual connection cable.
- 7. Fasten the shield clamp (2) to the drilled hole provided in the control PCB with the screw 3.5 × 6.5 (3). Tighten the screw hand-tight.

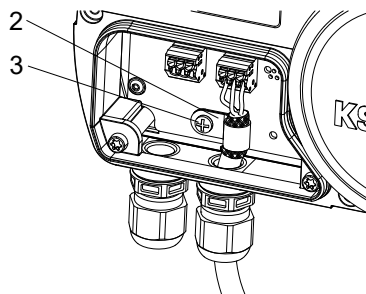

Fig. 15: Installing the dual connection cable

- 8. Wire the two pump sets to each other with the dual connection cable via the DUAL terminal pairs (a5).
- 9. Mount the cover of the terminal wiring compartment. Fasten it with the screws (1). Tightening torque = 0.8 Nm

1157.820/05-EN

⁷⁾ Included in the scope of supply of twin pumps

5.6.3 Connecting the general fault message

Table 10: Symbols key

Function	Symbol	Terminal pair	Maximum terminal cross-section	Terminal code	Contact rating
General fault message			1,5 mm ²	-	Min: 12 V DC at 10 mA Max: 250 V at 1 A

The pump set signals a general fault message by means of the integrated, volt-free relay contact.

- General fault message = pump rotor not rotating, no flow (alarm active).

This information can be accessed at the relay terminal pair with terminals NC / NO / C.



Fig. 16: Wiring diagram for the general fault message

1	No general fault message or no power supply / alarm not active
2	General fault message (pump rotor not rotating) / alarm active
NC	NC contact, normally closed and electrically conductive connection to C
C	Reference potential for either contact that is closed
NO	NO contact, normally open and not electrically conductive connection to C

- Switch off the power supply and make sure it cannot be switched on again unintentionally.
- Undo the screws (1) at the cover of the terminal wiring compartment at the electronic system housing with a suitable tool.

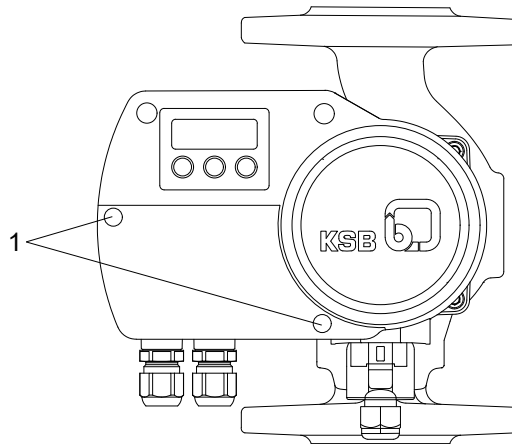

Fig. 17: Removing the cover of the terminal wiring compartment

- Prepare the cable gland that belongs to the terminal pair of the general fault message relay.

4. Guide the electric cable through the cable gland and into the connection space.
5. Screw the union nut and joint ring on hand-tight.
6. Wire the electric cable to the terminal pair of the general fault message relay.
See wiring diagram for the general fault message.
7. Mount the cover of the terminal wiring compartment. Fasten it with the screws (1). Tightening torque = 0.8 Nm

6 Commissioning/Start-up/Shutdown



6.1 Commissioning/Start-up

6.1.1 Prerequisites for commissioning/start-up

Before commissioning/starting up the pump set, make sure that the following conditions are met:

- The pump set has been properly connected to the power supply and is equipped with all protection devices. (⇒ Section 5.6, Page 28)
- The system piping has been cleaned. (⇒ Section 5.4, Page 26)
- The covers of the terminal wiring compartments have been closed and fastened with screws.



6.1.2 Priming and venting the pump

	<p>⚠ DANGER</p>
	<p>Non-compliance with the permissible pressure and temperature limits if the pump is operated with the suction and discharge lines closed.</p> <p>Hot fluids escaping!</p> <ul style="list-style-type: none"> ▷ Never operate the pump with the shut-off elements in the suction line and/or discharge line closed. ▷ Only start up the pump set against a slightly or completely open discharge-side shut-off element.
	<p>CAUTION</p>
	<p>Increased wear due to dry running</p> <p>Damage to the pump set!</p> <ul style="list-style-type: none"> ▷ Never operate the pump set without liquid fill. ▷ Never close the shut-off element in the suction line and/or supply line during pump operation. ▷ Observe the specified minimum pressure for operating the pump set. ▷ Always operate the pump set within the permissible operating range.
	<p>NOTE</p>
	<p>Twin pumps installed in a vertical position are self-venting. In a horizontal installation position the upper pump set can be manually vented via a vent plug.</p>

Venting the pump set in a vertical installation position

1. Fully open the shut-off elements in the suction line.
2. Slightly or fully open the shut-off element in the discharge line.

Venting the pump set in a horizontal installation position (twin pumps)

	<p>⚠ DANGER</p>
	<p>Hazardous electrical voltage when the covers of the terminal wiring compartments are removed</p> <p>Danger of death from electric shock!</p> <ul style="list-style-type: none"> ▷ For working on the terminals, switch off the power supply at least 5 minutes prior to commencing work and ensure that it cannot be switched on again unintentionally. ▷ If applicable, switch off the external power supply to message relays and control cables and make sure it cannot be switched on again unintentionally. ▷ Keep the covers of the terminal wiring compartments closed during operation as well as during maintenance work.
	<p>⚠ WARNING</p>
	<p>Hot fluid handled and manual venting</p> <p>Risk of scalding by escaping hot fluid!</p> <ul style="list-style-type: none"> ▷ Make sure that the fluid temperature is no higher than 40 °C for manual venting.

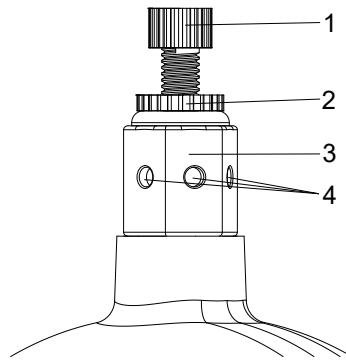

Fig. 18: Venting the pump set in a horizontal installation position





1	Vent valve	3	Vent plug
2	Ring	4	Drilled holes

- ✓ The vent plug⁸⁾ has been fitted.
- ✓ The pump set has been de-energised and secured against unintentional start-up.
 1. Fully open the shut-off elements in the suction line.
 2. Slightly or fully open the shut-off element in the discharge line.
 3. Slightly open the vent valve (1) until air escapes.
 4. When fluid handled escapes from the drilled holes (4), manually close the vent valve (1) hand-tight (1.5 Nm maximum), making sure it is tightly shut.
 5. Secure the vent valve (1) with the ring (2).

1157.820/05-EN

⁸ If applicable

6.1.3 Commissioning / Start-up

	<p style="background-color: #e67e22; color: white; padding: 5px;">⚠ DANGER</p> <p>Non-compliance with the permissible pressure and temperature limits if the pump is operated with the suction and discharge lines closed. Hot fluids escaping!</p> <ul style="list-style-type: none"> ▶ Never operate the pump with the shut-off elements in the suction line and/or discharge line closed. ▶ Only start up the pump set against a slightly or completely open discharge-side shut-off element.
	<p style="background-color: #e67e22; color: white; padding: 5px;">⚠ DANGER</p> <p>Excessive temperatures due to insufficient lubrication of the plain bearings Damage to the pump set!</p> <ul style="list-style-type: none"> ▶ Never operate the pump set without liquid fill. ▶ Properly prime the pump set. ▶ Vent the pump set. (⇒ Section 7.4.2, Page 55) ▶ Always operate the pump set within the permissible operating range.
	<p style="background-color: #f1c40f; padding: 5px;">⚠ WARNING</p> <p>Hot surfaces (pump and piping take on the temperature of the fluid handled). Risk of burns!</p> <ul style="list-style-type: none"> ▶ Do not touch hot surfaces. ▶ Use appropriate personal protective equipment.
	<p style="background-color: #f1c40f; padding: 5px;">CAUTION</p> <p>Abnormal noises, vibrations, temperatures or leakage Damage to the pump!</p> <ul style="list-style-type: none"> ▶ Switch off the pump (set) immediately. ▶ Eliminate the causes before returning the pump set to service.
	<p style="background-color: #f1c40f; padding: 5px;">CAUTION</p> <p>Increased wear due to dry running Damage to the pump set!</p> <ul style="list-style-type: none"> ▶ Never operate the pump set without liquid fill. ▶ Never close the shut-off element in the suction line and/or supply line during pump operation. ▶ Observe the specified minimum pressure for operating the pump set. ▶ Always operate the pump set within the permissible operating range.

- ✓ The system piping and the pump set have been primed with the fluid to be handled.
- 1. Fully open the shut-off elements in the suction line.
- 2. Fully open the shut-off element in discharge line.
- 3. Start up the pump set and let it run for approx. 1 minute.
- 4. Close the shut-off element in the discharge line.
- 5. Vent the pump. (⇒ Section 7.4.2, Page 55)
- 6. Fully open the shut-off element in discharge line.

6.2 Operating limits

	DANGER
	<p>Non-compliance with operating limits for pressure, temperature, fluid handled and speed Hot fluids escaping!</p> <ul style="list-style-type: none"> ▸ Comply with the operating data indicated in the data sheet. ▸ Avoid prolonged operation against a closed shut-off element. ▸ Never operate the pump at product temperatures exceeding those specified in the data sheet or on the name plate.

6.2.1 Frequency of starts

	CAUTION
	<p>Excessively high frequency of starts Damage to the pump set!</p> <ul style="list-style-type: none"> ▸ Do not exceed the values for the frequency of starts.

Maximum number of starts via power supply:

- Maximum 5 starts per hour
- Maximum 100 starts per 24 hours

6.2.2 Ambient temperature

	CAUTION
	<p>Operation outside the permissible ambient temperature Damage to the pump (set)!</p> <ul style="list-style-type: none"> ▸ Observe the specified limits for permissible ambient temperatures.

Observe the following parameters and values during operation:

Table 11: Permissible ambient temperatures specified for the fluid temperature

Fluid temperature [°C]	Permissible ambient temperature [°C]
≤ +90	+40
≤ +110	+30

6.2.3 Minimum inlet pressure

The minimum inlet pressure p_{min} at the pump suction nozzle serves to avoid cavitation noises at the indicated fluid temperature T_{max} .

The indicated values are applicable up to 300 m above sea level. For installation at altitudes > 300 m, an allowance of 0.01 bar / 100 m must be added.

Table 12: Minimum inlet pressure p_{min} specified for the fluid temperature T_{max} .

Fluid temperature [°C]	Minimum inlet pressure [bar]
≤ 80	0,5
81 to 95	1,5
96 to 110	2,5

6.2.4 Maximum operating pressure

	CAUTION
	<p>Permissible operating pressure exceeded Damage to connections and seals!</p> <ul style="list-style-type: none"> ▷ Never exceed the operating pressure specified in the data sheet.

The maximum operating pressure equals 6, 10 or 16 bar, depending on the design variant. See name plate. (⇒ Section 4.4, Page 16)

6.2.5 Fluid handled

6.2.5.1 Permissible fluids to be handled

	! DANGER
	<p>Use for drinking water or foodstuff applications Danger of poisoning!</p> <ul style="list-style-type: none"> ▷ Never use the pump for drinking water or foodstuff applications.

	CAUTION
	<p>Unsuitable fluids Damage to the pump!</p> <ul style="list-style-type: none"> ▷ Never use the pump to handle corrosive, combustible or explosive fluids. ▷ Never use the pump to handle waste water or abrasive fluids. ▷ Do not use the pump for foodstuff applications.

- Heating water to VDI 2035
- Higher-viscosity fluids (water/glycol mixture up to a mixing ratio of 1:1)

6.2.5.2 Density of the fluid handled

	CAUTION
	<p>Impermissibly high density of the fluid handled Motor overload!</p> <ul style="list-style-type: none"> ▷ Observe the information on fluid density in the data sheet.

The power input of the pump set will change in proportion to the density of the fluid handled.

6.2.5.3 Fluid temperature

	CAUTION
	<p>Incorrect fluid temperature Damage to the pump (set)!</p> <p>▷ Only operate the pump (set) within the temperature limits indicated.</p>

Table 13: Temperature limits of the fluid handled

Permissible fluid temperature	Value
Maximum	+110 °C
Minimum	-10 °C

The fluid temperature has an impact on the minimum inlet pressure.
 (⇒ Section 6.2.3, Page 37)

6.3 Shutdown

6.3.1 Shutdown

	NOTE
	<p>If the discharge line is equipped with a non-return or check valve, the shut-off element may remain open provided that the system conditions and system regulations are considered and observed.</p>

- ✓ The shut-off element in the suction line is and remains open.
 1. Close the shut-off element in the discharge line.
 2. Switch off the pump set.

For prolonged shutdown periods

	CAUTION
	<p>Risk of freezing during prolonged pump shutdown periods Damage to the pump!</p> <p>▷ Drain the pump and the cooling/heating chambers (if any) or otherwise protect them against freezing.</p>

1. Close the shut-off element in the suction line.

6.3.2 Measures to be taken for shutdown

The pump (set) remains installed



- ✓ Sufficient fluid is supplied for the functional check run of the pump.
 1. For prolonged shutdown periods, start up the pump (set) regularly between once a month and once every three months for approximately five minutes.
 - ⇒ This will prevent the formation of deposits within the pump and the pump intake area.

The pump (set) is removed from the pipe and stored

- ✓ The pump has been drained properly (⇒ Section 8.2, Page 58) and the safety instructions for dismantling the pump have been observed.
 1. Observe any additional instructions and information provided.
 (⇒ Section 3, Page 11)

1157.820/05-EN

6.4 Returning to service



	 WARNING
	<p>Failure to re-install or re-activate protective devices Risk of injury from moving parts or escaping fluid!</p> <ul style="list-style-type: none"> ▷ As soon as the work is completed, properly re-install and re-activate any safety-relevant devices and protective devices.

For returning the equipment to service, observe the sections on commissioning/start-up (⇒ Section 6.1, Page 34) and the operating limits (⇒ Section 6.2, Page 37) .

In addition, carry out all servicing/maintenance operations before returning the pump (set) to service. (⇒ Section 8, Page 58)



7 Operation

7.1 Control panel

	<p>NOTE</p> <p>If the control panel is locked, unlock it to be able to adjust its settings. (⇒ Section 7.4.1, Page 54)</p>
	<p>NOTE</p> <p>If 10 seconds pass without any settings being made or saved, the control unit will revert to the previous settings.</p>

All settings are made using the control element on the housing front. The control element comprises three control pushbuttons.

Table 14: Overview of control buttons

Control button	Function
	<ul style="list-style-type: none"> ▪ Select the operating mode. ▪ Turn on display backlighting. ▪ Save the setpoint.
	<ul style="list-style-type: none"> ▪ Change the operating mode. ▪ Increase the setting. ▪ Increase the setpoint.
	<ul style="list-style-type: none"> ▪ Change the operating mode. ▪ Reduce the setting. ▪ Reduce the setpoint.

7.1.1 Display

When the pump set is in operation, the display is in idle mode. As soon as one of the control buttons is pressed, the display is activated and shows the discharge head setpoint. If 5 minutes pass without any settings being made or the control buttons being pressed, the display will revert to idle mode.

The symbols indicate operating modes, functions and settings. Lit symbols indicate the active operating mode, function or setting.

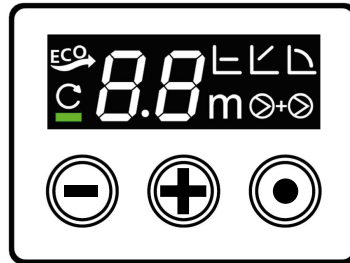

Fig. 19: Display

Table 15: Symbols key

Symbol	Description	Unit
m	Discharge head setpoint <ul style="list-style-type: none"> Symbol lights up. Display shows the set discharge head setpoint as a 2-digit number. 	m
⌊	Constant-pressure Control operating mode <ul style="list-style-type: none"> Symbol lights up when this operating mode is active. 	-
⌋	Proportional-pressure Control operating mode <ul style="list-style-type: none"> Symbol lights up when this operating mode is active. 	-
ECO →	Dynamic Control operating mode <ul style="list-style-type: none"> Symbol lights up when this operating mode is active. 	-
⌋	Open-loop Control operating mode <ul style="list-style-type: none"> Symbol lights up when this operating mode is active. 	-
↻ ■	Pump set status <ul style="list-style-type: none"> Smooth operation is indicated by the lit symbol and green LED. <ul style="list-style-type: none"> Pump set running. A warning is indicated by the lit symbol and orange LED. <ul style="list-style-type: none"> Pump set running. An alert is indicated by a red LED. The symbol is not lit in this case. <ul style="list-style-type: none"> Pump set stops. Stand-by mode is indicated by a green LED. The symbol is not lit in this case. <ul style="list-style-type: none"> In dual-pump operation (DUAL) one pump set is in stand-by mode. 	-
⊗+⊗	Dual-pump operation (DUAL) <ul style="list-style-type: none"> The symbol lights up when dual-pump mode is active. <ul style="list-style-type: none"> The pump sets are in duty mode or stand-by mode. 	-
8.8	Error message (e.g. alert 81) <ul style="list-style-type: none"> Warning / alerts are indicated by an error code (10 - 90) on the display. 	-

7.2 Operating modes

7.2.1 Information on settings

For common applications, such as two-pipe radiator heating systems, Dynamic Control or Proportional-pressure Control ($\Delta p-v$) are the recommended operating modes. These operating modes offer an extended control range with additional potential savings compared to Constant-pressure Control ($\Delta p-c$). Depending on the balancing of branch circuits, undersupply may occur at a consumer installation. Constant-pressure Control operating mode ($\Delta p-c$) can optionally be selected for underfloor heating systems, for example. If noises are audible at low flow rates, select the Proportional-pressure Control operating mode ($\Delta p-v$).

The setting of the discharge head setpoint depends on the piping curve of the system and on the heat requirements. As standard the pump set is pre-set to Proportional-pressure Control ($\Delta p-v$) operating mode.

Table 16: Default discharge head setpoint

Size	Pre-set discharge head setpoint
	[m]
Single pump	
25-40	2
25-60	3
25-80	4
25-100	5
30-40	2
30-60	3
30-80	4
30-100	5
30-120	6
32-40	2
32-60	3
32-80	4
32-100	5
32-120	6
40-40	2
40-60	3
40-70	3,5
40-80	4
40-90	4,5
40-100	5
50-40	2
50-60	3
50-80	4
50-90	4,5
65-60	3
Twin pump	
30-60	3
30-100	5
32-80	4
32-120	6
40-80	4
40-100	5
50-80	4

7.2.2 Constant-pressure Control

Applications

- Underfloor heating systems
- Solar pumps

Solar pumps require a high operating pressure to pump sufficient fluid through the heat exchanger. Proportional-pressure Control is not necessary as the thermostatic valves do not impact on the characteristic curve.

Function

In Constant-pressure Control the set head ② is maintained irrespective of the flow rate. The set discharge head setpoint H_s is constant, situated between the maximum curve ① and the permissible flow rate range.

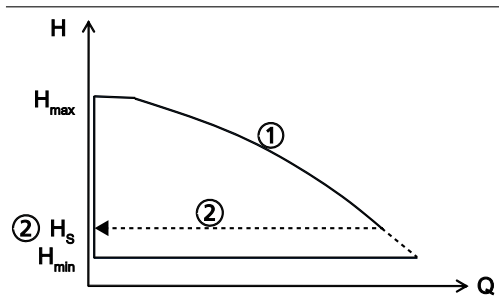

Fig. 20: Constant-pressure Control function

Setting

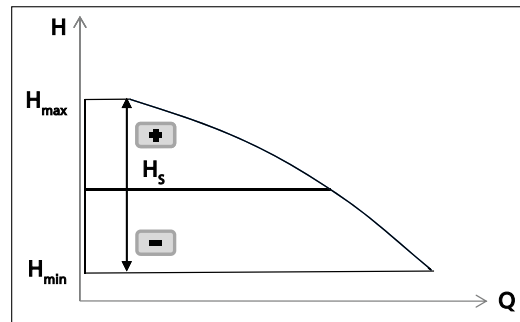

Fig. 21: Constant-pressure Control settings

Table 17: Selecting Constant-pressure Control and the setpoint

	<p>Step 1: Activating the setting mode</p> <ul style="list-style-type: none"> ▪ Press and hold the control button (●) for 3 seconds. <ul style="list-style-type: none"> – The flashing symbol indicates the active operating mode.
	<p>Step 2: Selecting the Constant-pressure Control operating mode</p> <ul style="list-style-type: none"> ▪ Press the control buttons (+) or (-) until the symbol for Constant-pressure Control flashes. ▪ Press the control button (●) to confirm the operating mode.
	<p>Step 3: Changing the setpoint</p> <ul style="list-style-type: none"> ▪ Increase or decrease the flashing discharge head setpoint by pressing the control buttons (+) or (-) respectively. ▪ Press the control button (●) to confirm the setpoint. <ul style="list-style-type: none"> – The selected setpoint lights up. It has been saved.

7.2.3 Proportional-pressure Control

Application

- Heating systems with radiators

The higher the flow rate, the higher the system's resistance. This is corrected by the pump set automatically increasing the discharge head setpoint.

When setting the setpoint ensure that the selected control curve is suitable for the system characteristic curve:

- If the system characteristic curve is known (e.g. hydraulic balancing), select a control curve that is minimally above the characteristic curve. See type series booklet.
 - Control curve too low: undersupply
 - Control curve too high: increased energy input
- If the system characteristic curve is unknown, Dynamic Control is recommended. (⇒ Section 7.2.4, Page 47)
 - The pump set automatically recognises the system characteristic curve via the variable speed system and optimises the operating point accordingly.

Function

Within the permissible flow rate range the Proportional-pressure Control decreases or increases the discharge head setpoint between $\frac{1}{2} H_s$ and H_s . The setpoint can be adjusted via the control panel.

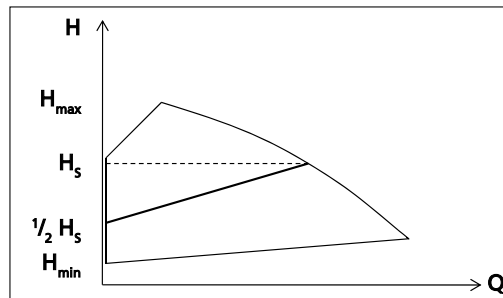

Fig. 22: Proportional-pressure Control function

Setting

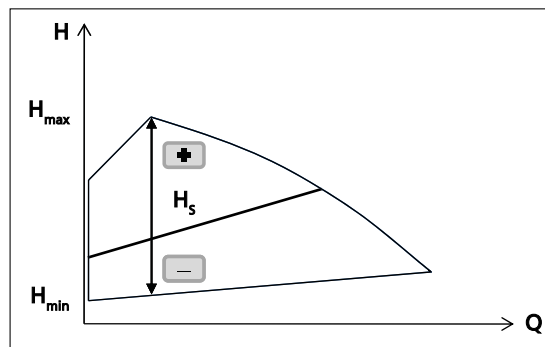
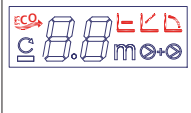
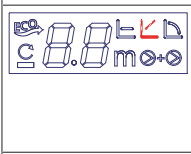



Fig. 23: Proportional-pressure Control settings

Table 18: Selecting Proportional-pressure Control and the setpoint

	<p>Step 1: Activating the setting mode</p> <ul style="list-style-type: none"> Press and hold the control button (●) for 3 seconds. <ul style="list-style-type: none"> The flashing symbol indicates the active operating mode.
	<p>Step 2: Selecting the Proportional-pressure Control operating mode</p> <ul style="list-style-type: none"> Press the control buttons (+) or (-) until the symbol for Proportional-pressure Control flashes. Press the control button (●) to confirm the operating mode.
	<p>Step 3: Changing the setpoint</p> <ul style="list-style-type: none"> Increase or decrease the flashing setpoint by pressing the control buttons (+) or (-) respectively. Press the control button (●) to confirm the setpoint. <ul style="list-style-type: none"> The selected setpoint lights up. It has been saved.

7.2.4 Dynamic Control

Application

- Heating systems with radiators

Dynamic Control is a more energy-efficient alternative to Proportional-pressure Control. The piping losses follow a quadratic system characteristic curve. Dynamic Control makes the pump set follow a quadratic control curve and automatically recognises the averaged degree of opening of the thermostatic valves.

When the thermostatic valves are closed or strongly throttled, the pump set’s head reduction exceeds that of the reduction specified by the quadratic control curve. The thermostatic valves open and maintain the required flow rate.

If the thermostatic valves do not respond further to the decreasing head, the pump set automatically switches back to the original control curve. This prevents any undersupply.

Function

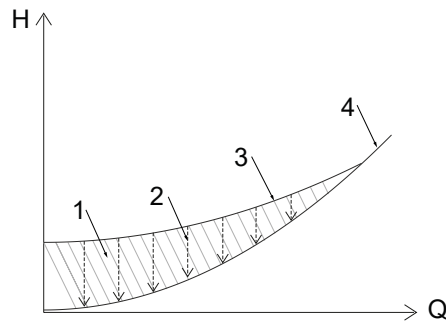

Fig. 24: Dynamic Control function

1	Excess energy input	3	Control curve
2	Dynamic Control	4	Minimum characteristic curve

The Dynamic Control (2) system detects when the selected control curve (3) is higher than the minimum characteristic curve⁹⁾ (4). The control system shifts the control curve downward, and power input is reduced automatically. To ensure sufficient supply the pump set switches to a higher control curve when the minimum characteristic curve is reached. The energy input is reduced (1) without any negative impact on the supply of the building.

The pump set is operated in an optimised way, even if the system characteristic curve is unknown; the noise at the thermostatic valves is reduced.

- If the system characteristic curve is known (e.g. hydraulic balancing):
 - Set the setpoint manually. Select a control curve that is minimally above the characteristic curve. See type series booklet.
 - Activating Dynamic Control in addition is recommended. Even if the setpoint has been set to an optimum, excessive throttling of the thermostatic valves may occur in certain climatic conditions. Dynamic Control will further optimise the operating point.
- If the system characteristic curve is unknown:
 - Use the standard settings and activate Dynamic Control. The pump set automatically recognises the system characteristic curve via the variable speed system and optimises the operating point accordingly.

1157.820/05-EN

⁹ Characteristic curve at fully open thermostatic valves

Settings

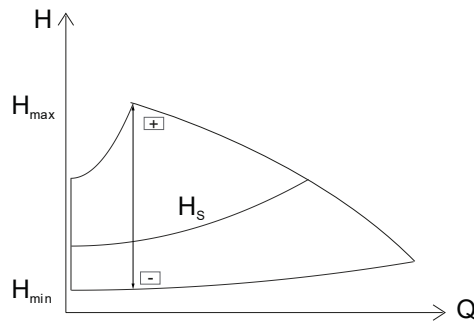

Fig. 25: Dynamic Control settings

Table 19: Activating and disabling Dynamic Control

	<p>Step 1: Activating the setting mode</p> <ul style="list-style-type: none"> Press and hold the control button (●) for 3 seconds. <ul style="list-style-type: none"> The flashing symbol indicates the active operating mode.
	<p>Step 2: Selecting Dynamic Control</p> <ul style="list-style-type: none"> Press the control buttons (+) or (-) until the symbol for Dynamic Control flashes. Press the control button (●) to confirm the operating mode.
	<p>Step 3: Changing the setpoint</p> <ul style="list-style-type: none"> Increase or decrease the flashing discharge head setpoint by pressing the control buttons (+) or (-) respectively. Press the control button (●) to confirm the setpoint. <ul style="list-style-type: none"> The selected setpoint lights up. It has been saved.

7.2.5 Open-loop control

Application

- Booster pump for supplying a heat distribution system

Function

In Open-loop Control operating mode the pump set runs at a set speed. The speed can be set to one of three speed levels.

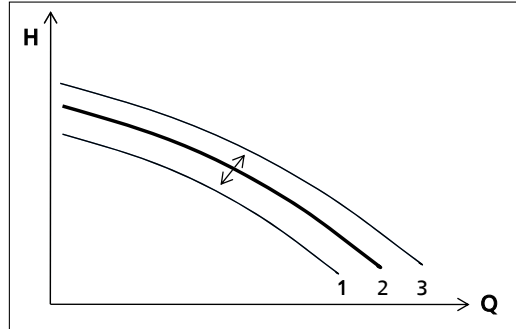

Fig. 26: Open-loop Control function

Setting

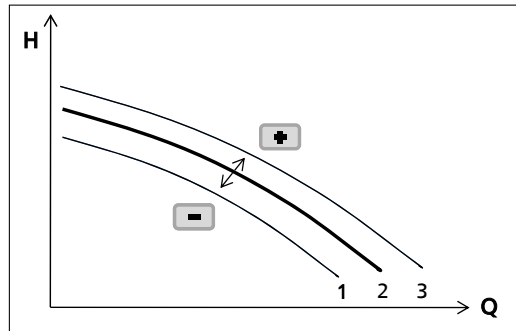



Fig. 27: Open-loop Control settings

Table 20: Selecting Open-loop Control and the setpoint

	<p>Step 1: Activating the setting mode</p> <ul style="list-style-type: none"> ▪ Press and hold the control button (●) for 3 seconds. <ul style="list-style-type: none"> – The flashing symbol indicates the active operating mode.
	<p>Step 2: Selecting the Open-loop Control operating mode</p> <ul style="list-style-type: none"> ▪ Press the control buttons (+) or (-) until the symbol for Open-loop Control flashes. ▪ Press the control button (●) to confirm the operating mode.
	<p>Step 3: Changing the setpoint</p> <ul style="list-style-type: none"> ▪ Increase or decrease the flashing setpoint by pressing the control buttons (+) or (-) respectively. <ul style="list-style-type: none"> – Setpoint 1 = Lower speed level – Setpoint 2 = Middle speed level – Setpoint 3 = Upper speed level ▪ Press the control button (●) to confirm the setpoint. <ul style="list-style-type: none"> – The selected setpoint lights up. It has been saved.

7.3 Functions

7.3.1 Dual-pump operation (DUAL)

	NOTE
	Connected pump sets will use the settings of the other pump sets.

Function

Activating the DUAL function starts dual-pump operation. The duty/stand-by mode becomes active after a few seconds and operation will stop one of the pump sets. The pump set remaining in duty mode is operated on the set control mode with the corresponding setpoint (duty). The second pump set is in stand-by mode.

Automatic pump changeover

The timers integrated in the pump sets stop the active (duty) pump set after 24 operating hours and start up the other (stand-by) pump set.

Redundant operation



Both pump sets run in alternation for 24 hours each. In the event of a pump set failure the other available pump set is started up.

Intelligent pump changeover

If a pump set used in dual-pump operation has been replaced, the operating hours per pump set can be balanced out with the intelligent pump changeover function. Regular pump changeover takes place every 24 hours. However, if the operating hours per pump set differ by more than 1000 hours, the pump set with the larger number of operating hours is operated for 24 hours before a pump changeover and the pump with the smaller number of operating hours is operated for 48 hours. Once the difference in operating hours per pump set drops below 1000, pump changeover reverts to the regular 24 hours for each pump set.

Setting

Table 21: Activating and deactivating the Dual-pump Operation (DUAL) operating mode

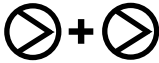
-	<p>Step 1: Activating the setting mode</p> <ul style="list-style-type: none"> ▪ Press and hold the control button (●) for 6 seconds. <ul style="list-style-type: none"> - The symbol flashes. <div style="text-align: center;"></div>
	<p>Step 2: Activating or deactivating Dual-pump Operation (DUAL)</p> <ul style="list-style-type: none"> ▪ Press the control button (●). <ul style="list-style-type: none"> - The symbol lights up: Dual-pump operation (DUAL) activated - The symbol goes out: Dual-pump operation (DUAL) deactivated <div style="text-align: center;"></div>

7.3.2 Protective functions

Function

The electronic motor protection automatically reduces the pump power in the event of overloading.

Available protective functions

- Protection against overheating
- Voltage monitoring
- Blocked pump rotor

Settings

None

7.3.3 Saving data

The operating data of the pump set are saved. Data storage will be maintained also when the pump is switched off or disconnected from the power supply. When the pump set is switched on again, it will be operated with the data that were active before the pump set was last switched off.

7.3.4 Error messages

Function

The pump set outputs warnings and alerts as a sequence of numbers and a combination of symbols and LEDs on the display.

Warnings:



Fig. 28: Pump set status: Warning

- The display shows the error code of the warning. The symbol **Pump set status** and an orange LED light up.
- The pump set keeps running in the set operating mode, possibly at a lower speed.
- The general fault message relay does not emit a message.

Alerts:



Fig. 29: Pump set status: Alert

- The display shows the error code of the alert. The symbol **Pump set status** extinguishes and a red LED lights up.
- The pump set has been stopped. / The motor is not rotating.
- The general fault message relay emits a message.
- If the pump control system cannot re-start the pump set automatically, the pump set continuously remains in fault status.

Example

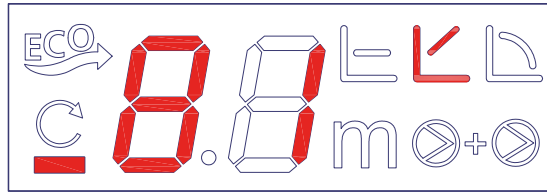

Fig. 30: Alert display (example)

Alert 81 is active.

When the alert is no longer active, the display will revert to the set operating mode. The settings of the pump set can then be changed again.

Table 22: Warnings

Error code	Cause	Action
14	The control system cannot detect the second pump set in dual-pump operation (DUAL).	Check the connection of the dual connection cable. Re-connect the dual connection cable if required. (⇒ Section 5.6.2, Page 30)
18	Pump set rotation in the direction of flow is caused by an externally forced flow.	Check the hydraulics of the system (system schematic / piping layout).
19	Pump set rotation in the reverse direction of flow is caused by an externally forced flow.	Check the hydraulics of the system (system schematic / piping layout). Fit a check valve if required.
51	The temperature limit inside the pump set has been reached. / The pump set is running at reduced speed.	Let the pump set cool down until the permissible temperature ranges are reached. If the temperature continues to rise, alert 51 is shown on the display and the red LED will light up. Verify the permissible temperature ranges of the fluid temperature and the ambient temperature. (⇒ Section 6.2, Page 37)
53	The temperature limit inside the pump set has been reached. / The pump set is running at reduced speed.	Let the pump set cool down until the warning clears. If the temperature continues to rise, alert 51 is shown on the display and the red LED will light up. Verify the permissible temperature ranges of the fluid temperature and the ambient temperature. (⇒ Section 6.2, Page 37)

Table 23: Alerts



Error code	Cause	Response
13	Electronic system fault	Reset to factory settings. (⇒ Section 7.5, Page 57) Disconnect the power supply for 1 minute. After 1 minute re-connect the power supply. Replace the pump set or contact KSBservice.
17	Pump set rotation is caused by an externally forced flow.	Check the hydraulics of the system (system schematic / piping layout). Fit a check valve if required.
2...	Electronic system fault	Disconnect the power supply for 1 minute. After 1 minute re-connect the power supply. Replace the pump set or contact KSBservice.
3...	Electronic system fault	Disconnect the power supply for 1 minute. After 1 minute re-connect the power supply. Replace the pump set or contact KSBservice.
40	Pump rotor blocked	Remove any contamination from the system.
51	Excessive temperature inside the pump set / Pump set has been stopped.	Interrupt the power supply and let the pump set cool down. Verify the permissible temperature ranges of the fluid temperature and the ambient temperature. (⇒ Section 6.2, Page 37)
53	Excessive temperature inside the pump set / Pump set has been stopped.	Interrupt the power supply and let the pump set cool down. Verify the permissible temperature ranges of the fluid temperature and the ambient temperature. (⇒ Section 6.2, Page 37)
61	Supply voltage below the permissible limit.	Verify the available supply voltage against the data on the name plate. Measure the supply voltage.
62	Supply voltage above the permissible limit.	Verify the available supply voltage against the data on the name plate. Measure the supply voltage.
70	Test alert	Disconnect the power supply. Re-establish the power supply or deactivate the test alert. (⇒ Section 7.4.3, Page 56)
8...	Motor fault	Disconnect the power supply for 1 minute. After 1 minute re-connect the power supply. Replace the pump set or contact KSBservice.

7.4 Additional functions

7.4.1 Locking / unlocking the control panel

Operating modes and functions can only be selected when the control panel is unlocked.

Table 24: Locking / unlocking the control panel

	<p>Step 1: Activating the additional function setting mode</p> <ul style="list-style-type: none"> ▪ Press and hold the control button (●) for 10 seconds. <ul style="list-style-type: none"> – The additional functions setting mode is active. – The symbol flashes. <p>HL</p>
<p style="text-align: center;">-</p>	<p>Step 2: Activating the setting mode</p> <ul style="list-style-type: none"> ▪ Press the control button (●). ▪ The current status of the control panel is shown. <p>H0 / H1</p>
 	<p>Step 3: Locking / unlocking the control panel</p> <ul style="list-style-type: none"> ▪ Select the required status by pressing the control buttons (+) or (-). <ul style="list-style-type: none"> – H0 = control panel unlocked – H1 = control panel locked ▪ Press the control button (●) to confirm the status.

7.4.2 Venting

Function

Venting requires the pump set to be in operation.

When the Venting function is activated, the pump set runs through a pre-set speed profile. The pump set automatically reduces and increases the setpoint and the speed.

When venting is completed, the pump set automatically switches to regular operation.

If the pump set is stopped during the venting process, the process is cancelled and venting has to be re-started.

Table 25: Activating / disabling venting

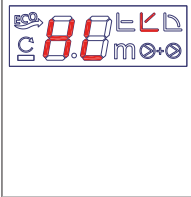
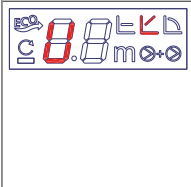
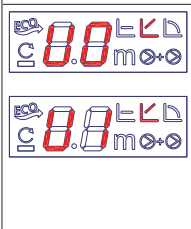
	<p>Step 1: Activating the additional function setting mode</p> <ul style="list-style-type: none"> ▪ Press and hold the control button (●) for 10 seconds. <ul style="list-style-type: none"> – The additional functions setting mode is active. – The symbol flashes. <p>HL</p>
	<p>Step 2: Selecting venting</p> <ul style="list-style-type: none"> ▪ Select the required function by pressing the control buttons (+) or (-). ▪ The symbol flashes. <p>U</p>
<p style="text-align: center;">-</p>	<p>Step 3: Activating the setting mode</p> <ul style="list-style-type: none"> ▪ Press the control button (●).
	<p>Step 4: Activating/disabling venting</p> <ul style="list-style-type: none"> ▪ Select the required status by pressing the control buttons (+) or (-). <ul style="list-style-type: none"> – U0 = venting disabled – U1 = venting activated ▪ Press the control button (●) to confirm the status.



7.4.3 Test alert

Function

The test alert can be used to check the connection of the general fault message. The test alert is indicated by alert 70 on the display, and the pump stops.

The test alert can be disabled by either disconnecting and re-connecting the power supply or via the control panel.

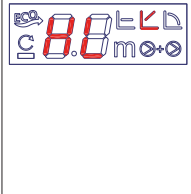
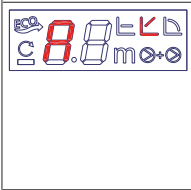
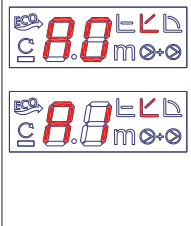
Table 26: Activating / deactivating the test alert

	<p>Step 1: Activating the additional function setting mode</p> <ul style="list-style-type: none"> ▪ Press and hold the control button (●) for 10 seconds. <ul style="list-style-type: none"> – The additional functions setting mode is active. – The symbol flashes. <p>HL</p>
	<p>Step 2: Selecting test alert</p> <ul style="list-style-type: none"> ▪ Select the required function by pressing the control buttons (+) or (-). ▪ The symbol flashes. <p>A</p>
<p style="text-align: center;">-</p>	<p>Step 3: Activating the setting mode</p> <ul style="list-style-type: none"> ▪ Press the control button (●).
 	<p>Step 4: Activating/disabling test alert</p> <ul style="list-style-type: none"> ▪ Select the required status by pressing the control buttons (+) or (-). <ul style="list-style-type: none"> – A-0 = test alert disabled – A-1 = test alert activated ▪ Press the control button (●) to confirm the status.

7.4.4 Information

Table 27: Displaying Information

	<p>Step 1: Activating the additional function setting mode</p> <ul style="list-style-type: none"> ▪ Press and hold the control button (●) for 10 seconds. <ul style="list-style-type: none"> – The additional functions setting mode is active. – The symbol flashes. <p>HL</p>
	<p>Step 2: Selecting Information</p> <ul style="list-style-type: none"> ▪ Select the required function by pressing the control buttons (+) or (-). <p>In</p>
<p>-</p>	<p>Step 3: Confirming the setting</p> <ul style="list-style-type: none"> ▪ Press the control button (●). <ul style="list-style-type: none"> – The pump size and the current firmware version are briefly shown on the display. – The display then changes automatically to its normal operating display.

7.5 Resetting to factory settings

Resetting to factory settings comprises the following settings:

Table 28: Factory setting

Operating mode	Proportional-pressure Control
Functions	Disables the dual-pump operation (DUAL) function
Setpoints	50 %

Table 29: Resetting to factory settings

<p>-</p>	<p>Step 1: Activating resetting</p> <ul style="list-style-type: none"> ▪ Press and hold the control button (●) for 30 seconds. <ul style="list-style-type: none"> – The display of the discharge head setpoint extinguishes. – The pump set has now been reset to factory settings.
----------	---

8 Servicing/Maintenance

8.1 Servicing/inspection

	NOTE
	<p>Any repairs on the pump must only be performed by one of our authorised service partners. Find your contact in the attached Addresses booklet or visit https://www.ksb.com/en-global/contact.</p>

The pump set is almost maintenance-free.
If the pump set has not been in operation for a prolonged period of time or if the system is severely contaminated, the pump rotor can become blocked.

8.2 Drainage/cleaning

	! WARNING
	<p>Fluids handled, consumables and supplies which are hot and/or pose a health hazard Hazard to persons and the environment!</p> <ul style="list-style-type: none"> ▷ Collect and properly dispose of flushing fluid and any fluid residues. ▷ Wear safety clothing and a protective mask if required. ▷ Observe all legal regulations on the disposal of fluids posing a health hazard.

1. Flush and clean the pump before transporting it to the workshop.
2. Provide a certificate of decontamination for the pump.





8.3 Removing the pump set from the piping

	! DANGER
	<p>Pump acting as a generator when running in reverse Danger to life from hazardous induction voltage at the motor terminals!</p> <ul style="list-style-type: none"> ▷ Prevent the fluid from flowing back by closing the shut-off elements.

	! DANGER
	<p>Open terminal wiring compartment Danger of death from electric shock!</p> <ul style="list-style-type: none"> ▷ Prior to removing the cover of the terminal wiring compartment, switch off the supply voltage and ensure that it cannot be switched on again unintentionally. ▷ Only open the cover of the terminal wiring compartment to connect / disconnect the general fault message relay and/or the dual connection cable. ▷ If applicable, switch off the external power supply to message relays and control cables and make sure it cannot be switched on again unintentionally. ▷ Keep the covers of the terminal wiring compartments closed during operation as well as during maintenance work.

	! DANGER
	<p>Work performed on an energised plug-type connector Danger of death from electric shock!</p> <ul style="list-style-type: none"> ▷ Switch off the supply voltage at least 5 minutes prior to commencing work and ensure that it cannot be switched on again unintentionally.

1157.820/05-EN

	<p>⚠ DANGER</p> <p>Strong magnetic field in the pump rotor area Danger of death for persons with pacemaker! Interference with magnetic data carriers, electronic devices, components and instruments! Uncontrolled magnetic attraction forces between magnet-equipped components, tools or similar!</p> <ul style="list-style-type: none"> ▷ Keep a safety distance of at least 0.3 m.
	<p>⚠ WARNING</p> <p>Strong magnetic field Danger of crushing injuries when pulling out the pump rotor! Strong magnetic field can suddenly pull the pump rotor back into its original position! Danger of magnetic parts near the pump rotor being attracted!</p> <ul style="list-style-type: none"> ▷ The pump rotor must be removed from the electronic system housing by authorised specialist personnel only. ▷ Remove any magnetic parts from the vicinity of the rotor. ▷ Keep the assembly area clean. ▷ Keep a safety distance of at least 0.3 m from electronic components.
	<p>⚠ WARNING</p> <p>Hot surface Risk of injury!</p> <ul style="list-style-type: none"> ▷ Allow the pump set to cool down to ambient temperature.
	<p>CAUTION</p> <p>Strong magnetic field in the pump rotor area Interference with magnetic data carriers, electronic devices, components and instruments! Uncontrolled magnetic attraction forces between magnetic components, tools or similar!</p> <ul style="list-style-type: none"> ▷ The rotor must generally be removed from the electronic system housing by authorised specialist personnel only. ▷ Remove any magnetic parts from the vicinity of the pump rotor. ▷ Keep the assembly area clean.

- ✓ The pump set has been de-energised and secured against unintentional start-up.
- ✓ The pump has cooled down to ambient temperature.
- ✓ A container for collecting the fluid has been positioned underneath the pump set.
 1. Close the shut-off elements.
 2. Disconnect the discharge nozzle and suction nozzle from the piping.
 3. Depending on the pump size / motor size, remove the supports from the pump set.
 4. Remove the complete pump set from the piping.

8.3.1 Removing the power cable

1. De-energise the pump set and make sure the pump set cannot be started up unintentionally.
2. Disconnect the plug-type connector from the pump set.
3. Lever out the contact insert with a suitable tool as shown in the illustration.

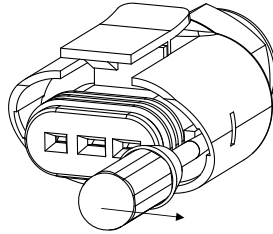



Fig. 31: Removing the contact insert

4. Pull the contact insert out of the plug housing.

9 Trouble-shooting

	 WARNING
	<p>Improper work to remedy faults</p> <p>Risk of injury!</p> <p>▷ For any work performed to remedy faults, observe the relevant information given in this operating manual and/or in the product literature provided by the accessories manufacturer.</p>

If problems occur that are not described in the following table, consultation with the KSB service is required.

- A Pump is running, but does not deliver
- B Pump does not start up or pump running irregularly
- C Pump running but not delivering water.
- D Noises during pump operation
- E Shown on the display

Table 30: Trouble-shooting

Error value	Possible cause	Remedy ¹⁰⁾
A	<ul style="list-style-type: none"> ▪ See Error messages (⇒ Section 7.3.4, Page 51) ▪ The Pump set status symbol in the display extinguishes and the green LED lights up (service mode activated). 	<ul style="list-style-type: none"> ▪ Disconnect the power supply. Then re-establish the power supply. Check the power supply and fuses. ▪ Disconnect the plug (power cable) or press the control buttons (+) and (-) simultaneously for 20 seconds until the Pump set status symbol lights up again on the display (service mode deactivated).
B	<ul style="list-style-type: none"> ▪ Impurities in the pump 	<ul style="list-style-type: none"> ▪ (⇒ Section 8.1, Page 58)
B	<ul style="list-style-type: none"> ▪ Blockage in the pump 	<ul style="list-style-type: none"> ▪ (⇒ Section 8.1, Page 58)
C	<ul style="list-style-type: none"> ▪ Air in the system ▪ Shut-off elements closed 	<ul style="list-style-type: none"> ▪ Vent the system and the pump. (⇒ Section 6.1.3, Page 36) ▪ Open the shut-off elements.
D	<ul style="list-style-type: none"> ▪ Power too high ▪ System pressure too low ▪ Air in the system ▪ Pump running dry 	<ul style="list-style-type: none"> ▪ Decrease the discharge head setpoint. ▪ Increase the system pressure by filling more water into the boiler. ▪ Vent the system and the pump. (⇒ Section 6.1.3, Page 36) ▪ Prime the pump. (⇒ Section 6.1.3, Page 36)
E	<ul style="list-style-type: none"> ▪ See Error messages (⇒ Section 7.3.4, Page 51) 	<ul style="list-style-type: none"> ▪ See Error messages (⇒ Section 7.3.4, Page 51)

¹⁰⁾ Release pump set pressure before attempting to remedy faults on components which are subjected to pressure.

10 Related Documents

10.1 Sectional drawing with list of components

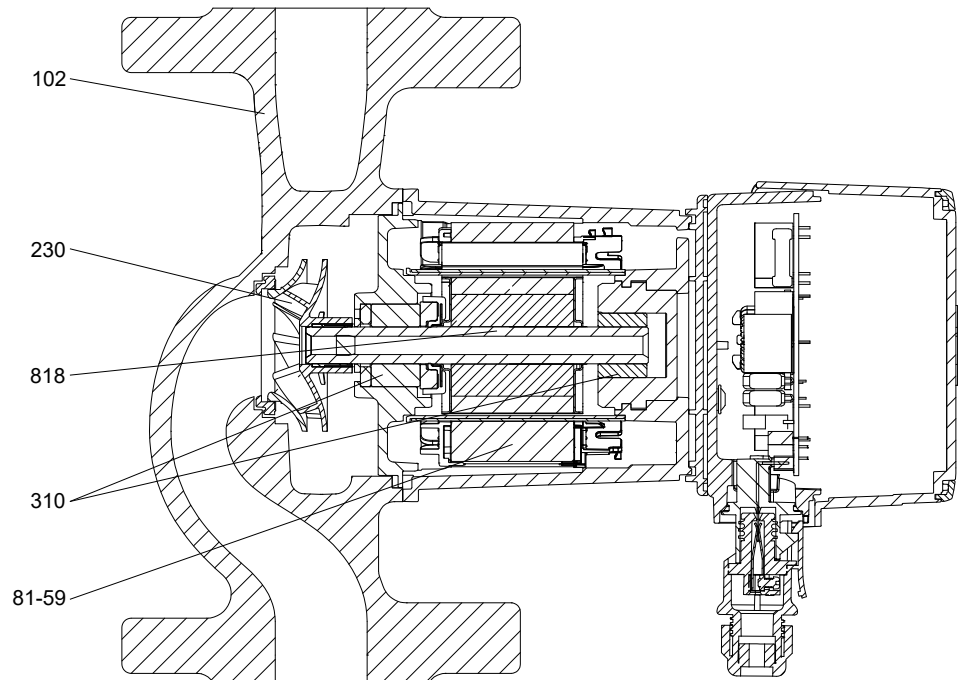

Fig. 32: Sectional drawing

Table 31: List of components

Part No.	Description	Part No.	Description
102	Volute casing	81-59	Stator
230	Impeller	818	Pump rotor
310	Plain bearing		

11 EU Declaration of Conformity

Manufacturer: **KSB SE & Co. KGaA**
Johann-Klein-Straße 9
67227 Frankenthal (Germany)

This EU Declaration of Conformity is issued under the sole responsibility of the manufacturer.

The manufacturer herewith declares that **the product:**

Calio Pro, Calio Pro Z

From serial number: xxxxxxxx-A202143-00001

- is in conformity with the provisions of the following directives / regulations as amended from time to time:
 - 2006/42/EC Machinery Directive
(The safety objectives set out in the 2014/35/EU EC Directive on Low-voltage Equipment are observed.)
 - 2009/125/EC: Creation of a framework for the stipulation of requirements for the environmentally compatible design of energy-related products (Ecodesign Directive), Regulation No. 641/2009 and/or 622/2012
 - 2011/65/EU: Restriction of the Use of Certain Hazardous Substances in Electrical and Electronic Equipment (RoHS)
 - 2014/30/EU: Electromagnetic Compatibility (EMC)

The manufacturer also declares that

- the following harmonised international standards have been applied:
 - EN 809: 1998+A1:2009/AC:2010
 - EN 60335-1:2012+AC:2014+A11:2014+A13:2017+A1:2019+A14:2019+A2:2019+A15:2021
 - EN 60335-2-51:2003+A1:2008+A2:2012
 - EN 62233:2008+AC:2008
 - EN 16297-1:2012, EN 16297-2:2012
- the following international standards have been applied:
 - EN 55014-1:2021, EN 55014-2:2021
 - EN 61000-3-2:2019+A1:2021, EN 61000-3-3:2013+A1:2019

Person authorised to compile the technical file:

Jennifer Watson
Product Development Pump Systems & Drives
KSB SE & Co. KGaA
Johann-Klein-Straße 9
67227 Frankenthal (Germany)

The EU Declaration of Conformity was issued in/on:

Frankenthal, 7 February 2023



Jochen Schaab
Head of Product Development Pump Systems & Drives
KSB SE & Co. KGaA
Johann-Klein-Straße 9
67227 Frankenthal (Germany)

Index

A

Applications 8
Automatic functions 17

B

Bearings 17

C

Commissioning 34
Commissioning / Start-up 36
Connections 17

D

Design 17
Designation 15
Disposal 13
Drive 17

E

Event of damage 6

F

Faults
 Causes and remedies 61
Fluid handled
 Density 38

I

Installation at site 21
Intended use 8

K

Key to safety symbols/markings 7

M

Manual functions 17

N

Name plate 16

O

Operating limits 37
Operating modes 17
Other applicable documents 6

P

Piping 26
Preservation 12, 39
Product description 15

R

Return to supplier 13
Returning to service 40

S

Safety 8
Safety awareness 9
Scope of supply 20
Shutdown 39
Signalling and display functions 18
Storage 12, 39

T

Transport 11

W

Warnings 7
Warranty claims 6



KSB SE & Co. KGaA

Johann-Klein-Straße 9 • 67227 Frankenthal (Germany)

Tel. +49 6233 86-0

www.ksb.com