

High-efficiency Heating Circulator

Calio

Type Series Booklet



Legal information/Copyright

Type Series Booklet Calio

All rights reserved. The contents provided herein must neither be distributed, copied, reproduced, edited or processed for any other purpose, nor otherwise transmitted, published or made available to a third party without the manufacturer's express written consent.

Subject to technical modification without prior notice.

© KSB SE & Co. KGaA, Frankenthal 2023-01-24

Contents

Building Services: Heating..... 4

 Variable Speed Heating Circulators 4

 Calio 4

 Main applications..... 4

 Fluids handled 4

 Operating data..... 4

 Design details 4

 Designation 5

 Materials..... 5

 Product benefits..... 6

 Product information 6

 Certifications 6

 Selection information 7

 Technical data 9

 Selection chart..... 10

 Characteristic curves..... 11

 Dimensions 28

 Installation information..... 29

 Scope of supply 29

 Accessories..... 30

Building Services: Heating

Variable Speed Heating Circulators

Calio



Main applications

- Heating, ventilation, air-conditioning, cooling and circulation systems
- One-pipe systems and two-pipe systems
- Underfloor heating systems
- Boiler circuits or primary circuits
- Storage tank circuits
- Solar power systems
- Heat pumps

Fluids handled

- Heating water to VDI 2035
- Higher-viscosity fluids (water/glycol mixture up to a mixing ratio of 1:1)

Operating data

Table 1: Operating properties

Characteristic		Value
Flow rate	Q [m ³ /h]	≤ 51
	Q [l/s]	≤ 14,2
Head	H [m]	≤ 18
Fluid temperature	T [°C]	≥ -10
		≤ +110
Ambient temperature	T [°C]	≥ 0
		≤ +40 ¹⁾
Operating pressure	p [bar]	≤ 16
Pressure class	PN [bar]	6/10/16
Average sound pressure level	[dB (A)]	< 45 ²⁾
Screw-ended connection	G	1 1/2 - 2
Flanged connection	DN	32 - 100

Design details

Design

- Maintenance-free high-efficiency wet rotor pump (glandless)

Drive

- High-efficiency permanent magnet synchronous motor, brushless, self-cooling, with continuously variable differential pressure control
- Integrated motor protection
- 1~230 V AC +/- 10%
- Frequency 50 Hz/60 Hz
- Enclosure IPX4D
- Thermal class F
- Temperature class TF 110
- Energy efficiency index EEI ≤ 0.20³⁾

P1 < 400 W:

- Interference emissions EN 55014-1, EN 61000-3-2, EN 61000-3-3
- Interference immunity EN 55014-2

P1 > 400 W:

- Interference emissions EN 61800-3
- Interference immunity EN 61800-3

Bearings

- Product-lubricated special plain bearing

Connections

- Screw-ended or flanged

¹ Ambient temperature ≤ + 30 °C at a fluid temperature > 90 °C

² Calio 100-60: < 49 dB (A)

³ Calio 40-90: EEI = 0.22 and Calio 50-90: EEI = 0.21

Operating modes

- Constant-pressure control
- Proportional-pressure control
- Temperature-governed differential pressure control (can only be activated with KSB ServiceTool)
- Open-loop control via setpoint setting
- Eco Mode

Automatic functions

- Continuously variable speed adjustment depending on the mode of operation
- 0 - 10 V with external differential pressure/speed setpoint
- 0 - 10 V as input of the actual value of the temperature or actual value of the differential pressure
- Dual-pump operation
- Peak load operation (can only be enabled with KSB ServiceTool)
- Setback operation
- Dynamic Control
- Remote ON/OFF

- Deblocking function
- Self-venting function
- Soft start
- Full motor protection with integrated trip electronics

Manual functions

- Setting the operating mode
- Setting the discharge head setpoint
- Setting the speed level
- Locking the control panel

Signalling functions and display functions

- Periodically alternating display of flow rate, head and electrical input power
- Operating status shown on the display
- Error codes indicated on the display
- Configurable general fault message and "in operation" message (voltage-free changeover contacts)
- Serial digital Modbus RTU interface
- Service interface for KSB ServiceTool

Designation

Example: Calio 40-180

Table 2: Designation key

Code	Description	
Calio	Type series	
40	Connection	
	25	G 1 1/2
	30	G 2
	32	DN 32
	40	DN 40
	50	DN 50
	65	DN 65
	80	DN 80
	100	DN 100
180	Head H ⁴⁾ [m]	
	180	Head × 10 Example: 18 m × 10 = 180

Materials

Table 3: Overview of available materials

Part No.	Description	Material
102	Volute casing	Grey cast iron with cathodic electrocoating (EN-GJL-200)
210	Shaft	Stainless steel 1.4034
230	Impeller	Plastic with glass fibre content (PSU-GF30)
310	Bearing	Ceramics/carbon
689	Thermal insulation shells	Polypropylene
817	Can	Stainless steel 1.4301

Casing parts which are in contact with the atmosphere and with the fluid handled are free from paint-wetting impairment materials.

⁴ At flow rate Q = 0 m³/h

Product benefits

- High-efficiency technology combined with speed control and efficient operation by means of **Dynamic Control** offer maximum savings.
- Future-proof by maximum energy efficiency, exceeding current energy efficiency regulations such as ErP 2015.
- All-in concept saves investment costs and commissioning costs.
- Easy-to-use combination of controls, integrated display and symbols to show the operating status
- High availability by dual-pump operation and integrated protective functions
- New Eco Mode enables additional savings of more than 40 % compared to proportional-pressure control.
(⇒ Page 8)

Product information

Product information as per Regulation No. 1907/2006 (REACH)

For information as per European chemicals regulation (EC) No. 1907/2006 (REACH) see <https://www.ksb.com/en-global/company/corporate-responsibility/reach>.

Certifications

Table 4: Overview

Label	Effective in:	Comment
	Europe	EEl ≤ 0,20 ⁵⁾

⁵⁾ At 50-90: EEl = 0.21 and 40-90: EEl = 0.22

Selection information

Minimum inlet pressure

The minimum inlet pressure p_{min} at the pump suction nozzle serves to avoid cavitation noises at the indicated fluid temperature T_{max} .

The indicated values are applicable up to 300 m above sea level. For installation at altitudes > 300 m, an allowance of 0.01 bar / 100 m must be added.

Table 5: Minimum inlet pressure p_{min} specified for the fluid temperature T_{max} .

Fluid temperature [°C]	Minimum inlet pressure [bar]
≤ 80	0,5
81 to 95	1,5
96 to 110	2,5

Permissible fluid temperature

Table 6: Temperature limits of the fluid handled

Permissible fluid temperature	Value
Maximum	+110 °C
Minimum	-10 °C

Permissible ambient temperature

Table 7: Permissible ambient temperatures specified for the fluid temperature

Fluid temperature [°C]	Permissible ambient temperature [°C]
≤ +90	+40
> +90	+30

Description of the Modbus interface

Table 8: Technical data of the Modbus interface

Parameter	Description/value
Terminal cross-section	1,5 mm ²
Interface	RS485 (TIA-485-A) optically isolated
Bus connection	0.5 mm ² , shielded twisted pair bus cable
Cable length	<ul style="list-style-type: none"> ▪ 1000 m max. ▪ Stub line impermissible ▪ For cable lengths > 30 m take suitable measures to ensure overvoltage protection.
Wave impedance	120 Ω (cable type B to TIA-485-A)
Data rates [baud]	4800, 9600, 38,400, 57,600, 115,200 (19,200 = factory setting)
Protocol	Modbus RTU standard
Data format	<ul style="list-style-type: none"> ▪ 8 data bits ▪ Parity EVEN / ODD / NONE ▪ 1 stop bit
Modbus address	ID #1 to #247 selectable (ID #17 = factory setting)

 Further description see operating manual of the pump set.

Description of the Eco Mode

In Eco Mode, the pump characteristic curve (1) is quadratic. Starting at the discharge head setpoint H_s , the characteristic curve intersects the discharge head axis at $H_0 = 1/4 \times H_s$. By changing the differential pressure setpoint this pump characteristic curve can be adjusted to higher or lower differential pressures or discharge heads. Compared with the Proportional-pressure Control operating mode the Eco Mode can save more than 40 % in electrical input power. An example of a characteristic curve of a pump in Eco Mode is shown below.

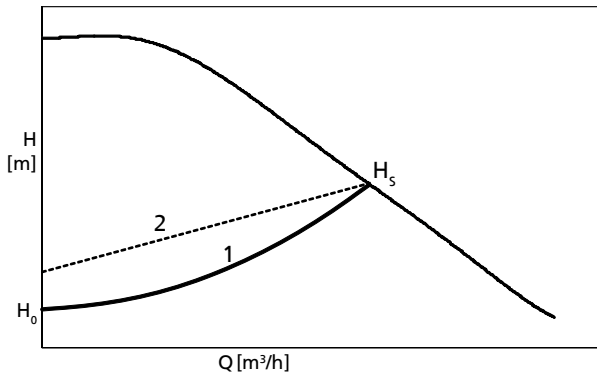

Fig. 1: Eco Mode function

1	Eco Mode characteristic curve
2	Proportional-pressure Control characteristic curve for comparison

Dynamic Control description

The dynamic control (2) system detects when the selected control curve (3) is higher than the minimum characteristic curve⁶ (4). The control system shifts the control curve downward, and power input is reduced automatically. To ensure sufficient supply the pump set switches to a higher control curve when the minimum characteristic curve is reached. The energy input is reduced (1) without any negative impact on the supply of the building. The pump set is operated in an optimised way, even if the system characteristic curve is unknown; the noise at the thermostatic valves is reduced.

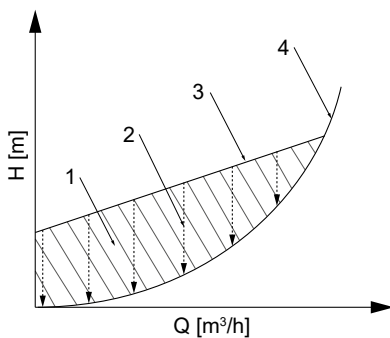

Fig. 2: Principle of dynamic control

1	Excess energy input	3	Control curve
2	Dynamic control	4	Minimum characteristic curve

Description of the characteristic curve

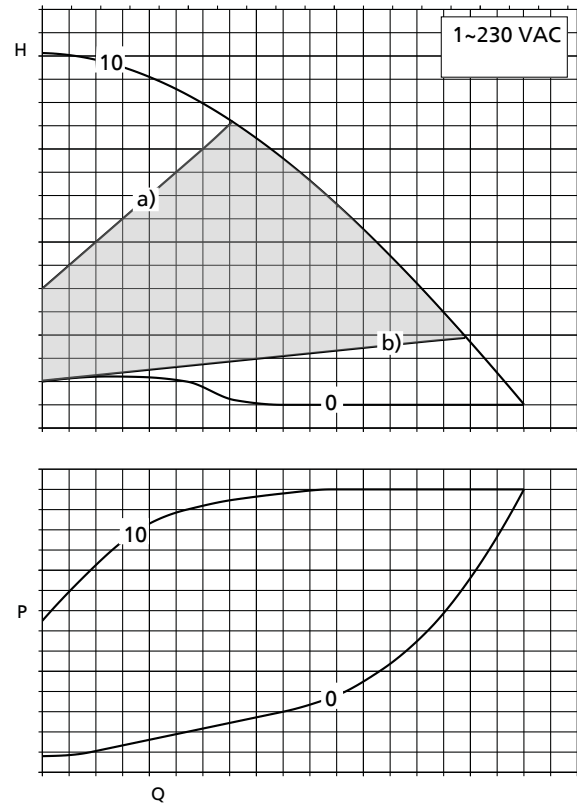

Fig. 3: Selection example

i The pump characteristic curve can be adjusted between a) and b) in increments of 1 % by turning the control element.

0	Level 0 = open-loop control, minimum speed (corresponds to a setting of 0 %)
10	Level 10 = open-loop control, maximum speed (corresponds to a setting of 100 %)
	Control range
a)	Control curve, maximum head
b)	Control curve, minimum head

⁶ Characteristic curve at fully open thermostatic valves

Technical data
Calio
Table 9: Technical data

Size	Connection		PN [bar]	n		P ₁ [W]	I _N 1-230 V AC, 50 Hz/60 Hz [A]	Mat. No.	[kg]
	Piping	Pump		Min.	Max.				
				[rpm]	[rpm]				
25-40	R 1	G 1 1/2	6/10/16	1000	2900	3,5 - 95	0,15 - 0,41	29134911	5,3
25-60	R 1	G 1 1/2	6/10/16	1000	3500	3,5 - 180	0,15 - 0,78	29134912	5,3
25-80	R 1	G 1 1/2	6/10/16	1000	4000	3,5 - 200	0,15 - 0,87	29134913	5,3
25-100	R 1	G 1 1/2	6/10/16	1000	4500	3,5 - 210	0,15 - 0,91	29134914	5,3
30-40	R 1 1/4	G 2	6/10/16	1000	2900	3,5 - 70	0,15 - 0,30	29134915	5,5
30-60	R 1 1/4	G 2	6/10/16	1000	3500	3,5 - 140	0,15 - 0,61	29134916	5,5
30-80	R 1 1/4	G 2	6/10/16	1000	4000	3,5 - 180	0,15 - 0,78	29134917	5,5
30-100	R 1 1/4	G 2	6/10/16	1000	4500	3,5 - 210	0,15 - 0,91	29134918	5,5
30-120	R 1 1/4	G 2	6/10/16	1000	4000	3,5 - 370	0,15 - 1,61	29134919	6,46
32-40	DN 32	DN 32	6/10/16	1000	2900	3,5 - 75	0,15 - 0,33	29135102	9,62
32-60	DN 32	DN 32	6/10/16	1000	3500	3,5 - 145	0,15 - 0,63	29135103	9,62
32-80	DN 32	DN 32	6/10/16	1000	4000	3,5 - 185	0,15 - 0,81	29135104	9,62
32-100	DN 32	DN 32	6/10/16	1000	4500	3,5 - 215	0,15 - 0,94	29135105	9,62
32-120	DN 32	DN 32	6/10/16	1000	4000	3,5 - 360	0,15 - 1,57	29134920	9,62
40-40	DN 40	DN 40	6/10/16	1000	3200	3,5 - 140	0,15 - 0,61	29135106	8,68
40-60	DN 40	DN 40	6/10/16	1000	3700	3,5 - 120	0,15 - 0,52	29134921	8,68
40-70	DN 40	DN 40	6/10/16	1000	3900	3,5 - 150	0,15 - 0,65	29134922	8,68
40-80	DN 40	DN 40	6/10/16	1000	3600	3,5 - 300	0,15 - 1,30	29134923	11,49
40-90	DN 40	DN 40	6/10/16	1000	4500	3,5 - 190	0,15 - 0,83	29134924	8,68
40-100	DN 40	DN 40	6/10/16	1000	4000	3,5 - 400	0,15 - 1,74	29134925	11,49
40-120	DN 40	DN 40	6/10/16	1000	2900	5 - 500	0,32 - 2,17	29134862	20,5
40-180	DN 40	DN 40	6/10/16	1000	3500	5 - 700	0,32 - 3,00	29134863	20,5
50-40	DN 50	DN 50	6/10/16	1000	3200	3,5 - 140	0,15 - 0,61	29134926	9,9
50-60	DN 50	DN 50	6/10/16	1000	3300	3,5 - 300	0,15 - 1,30	29134927	12,87
50-80	DN 50	DN 50	6/10/16	1000	3500	3,5 - 370	0,15 - 1,61	29134928	12,87
50-90	DN 50	DN 50	6/10/16	1000	4500	3,5 - 200	0,15 - 0,87	29134929	9,9
50-100	DN 50	DN 50	6/10/16	1000	2750	5 - 450	0,32 - 1,96	29134864	21,6
50-120	DN 50	DN 50	6/10/16	1000	2930	5 - 500	0,32 - 2,17	29134865	21,6
50-150	DN 50	DN 50	6/10/16	1000	3260	5 - 630	0,32 - 2,74	29134866	21,6
50-180	DN 50	DN 50	6/10/16	1000	3600	5 - 710	0,32 - 3,10	29134867	21,6
65-60	DN 65	DN 65	6/10/16	1000	3100	3,5 - 380	0,15 - 1,65	29134930	17,56
65-120	DN 65	DN 65	6/10/16	1000	3200	5 - 820	0,32 - 3,60	29134868	29,7
80-80	DN 80	DN 80	6	1000	2400	5 - 670	0,32 - 2,91	29134869	31,4
80-80	DN 80	DN 80	10/16	1000	2400	5 - 670	0,32 - 2,91	29134870	31,4
100-60	DN 100	DN 100	6	1000	2100	5 - 770	0,32 - 3,40	29134871	39,4
100-60	DN 100	DN 100	10/16	1000	2100	5 - 790	0,32 - 3,40	29134872	39,4

Selection chart

Calio

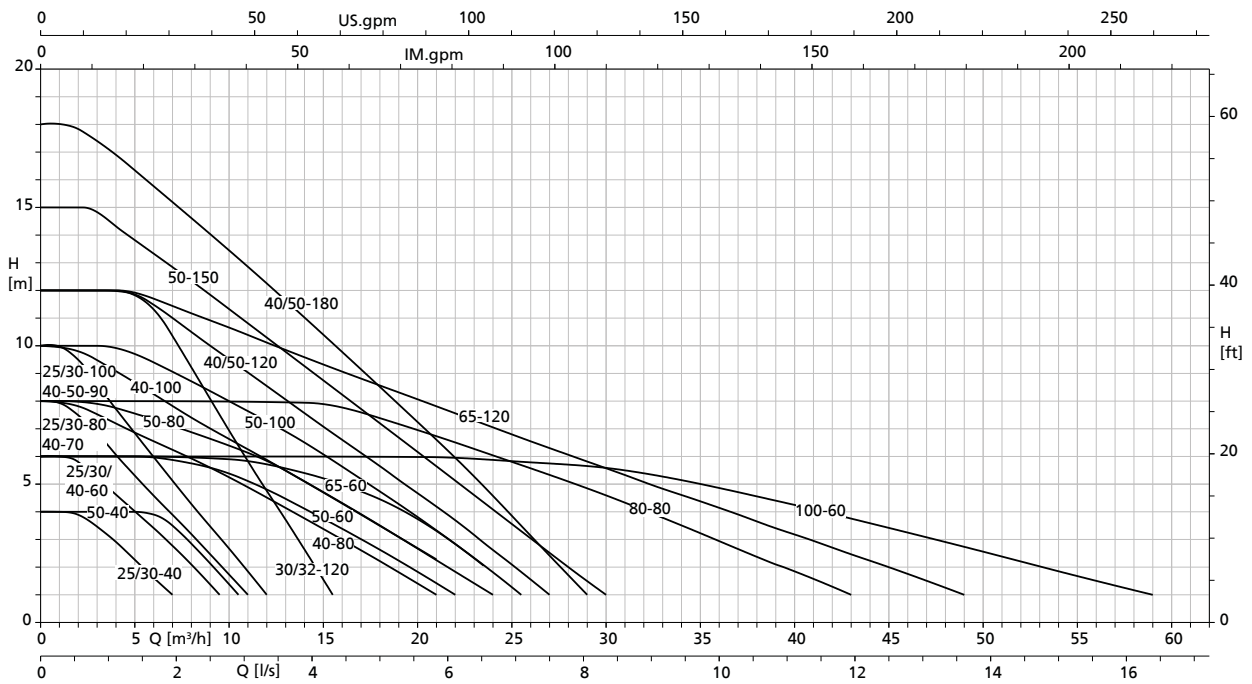

Characteristic curves

Calio 25-40 Open-loop Control, Eco Mode

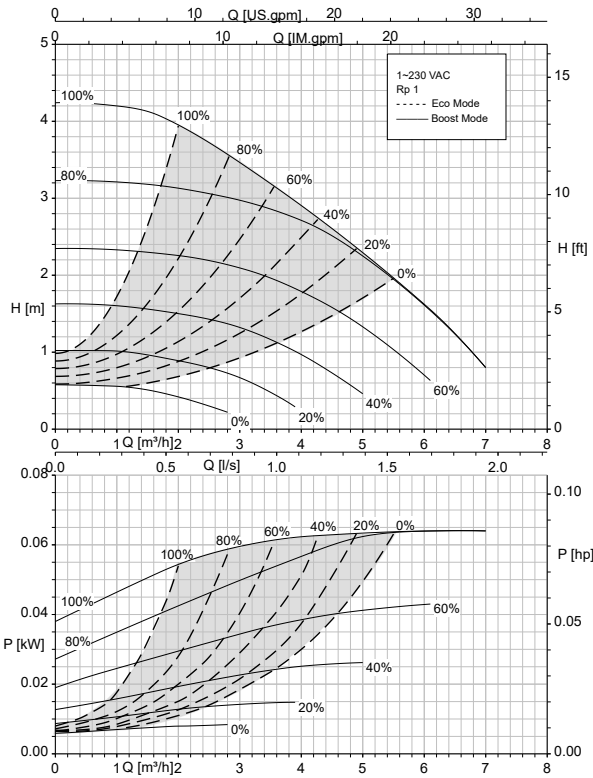

Calio 25-40 Δp_v , Δp_c

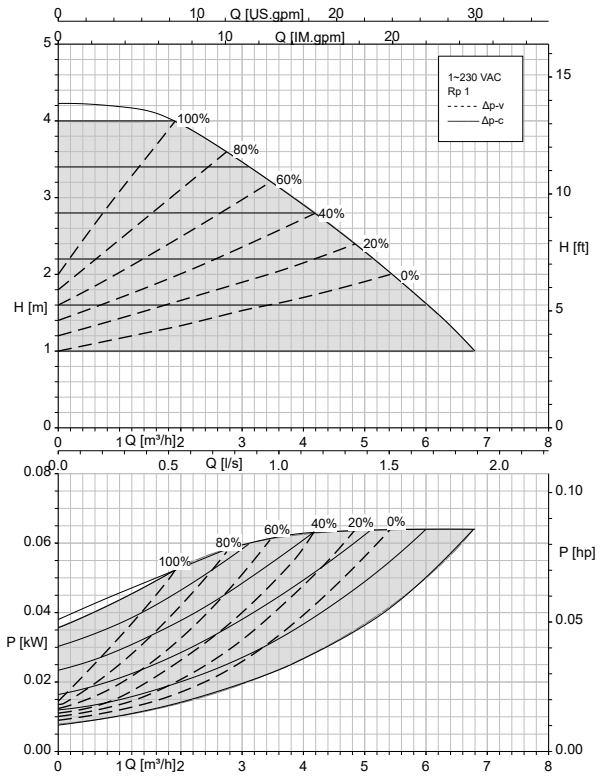

Calio 25-60 Open-loop Control, Eco Mode

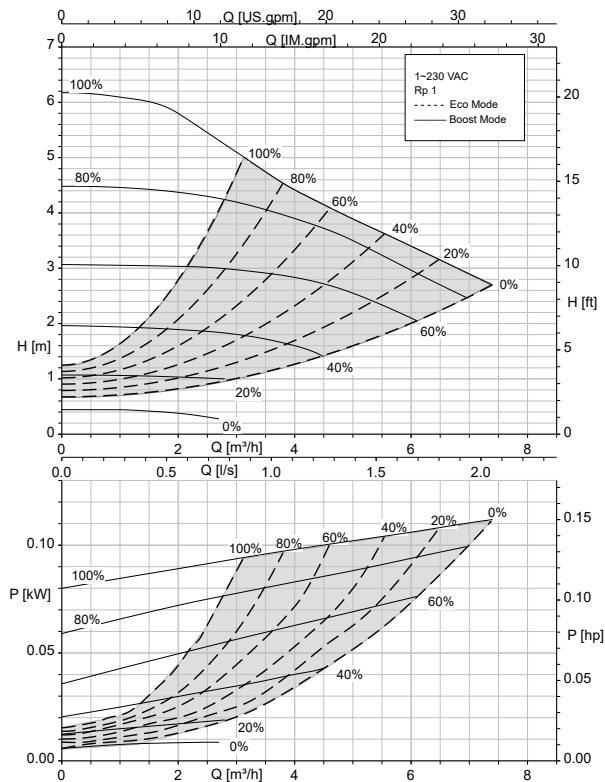

Calio 25-60 Δp_v , Δp_c

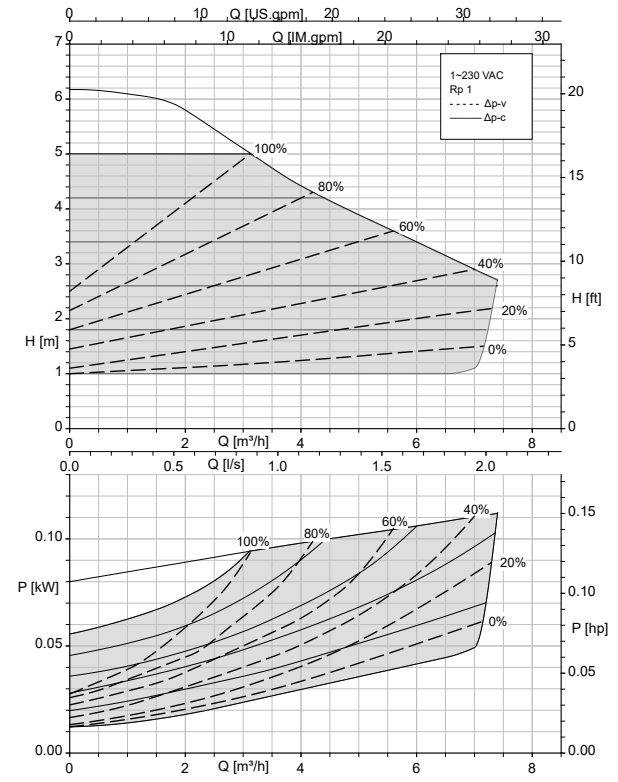

1157.59/10-EN

Calio 25-80 Open-loop Control, Eco Mode

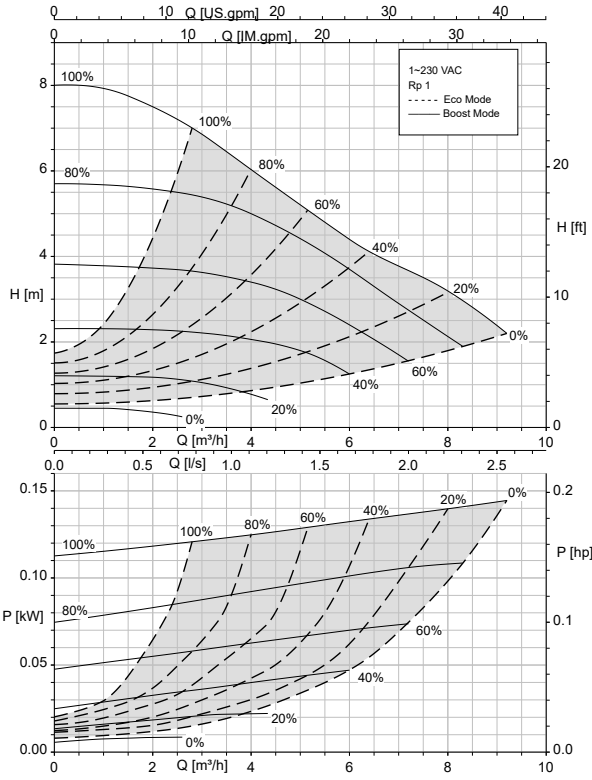

Calio 25-80 Δp_v , Δp_c

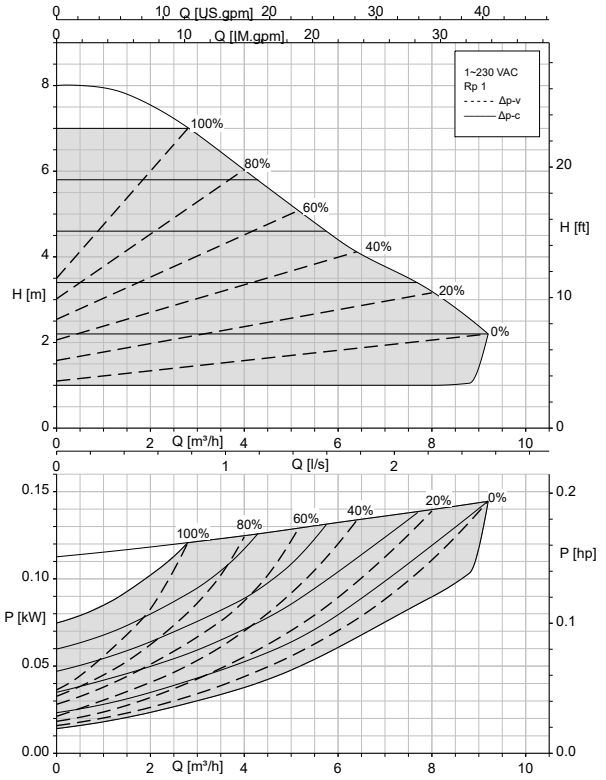

Calio 25-100 Open-loop Control, Eco Mode

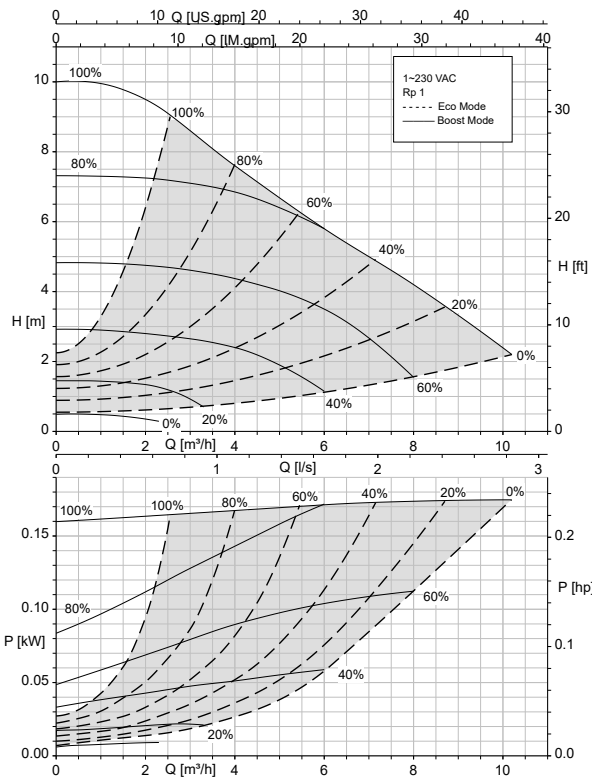

Calio 25-100 Δp_v , Δp_c

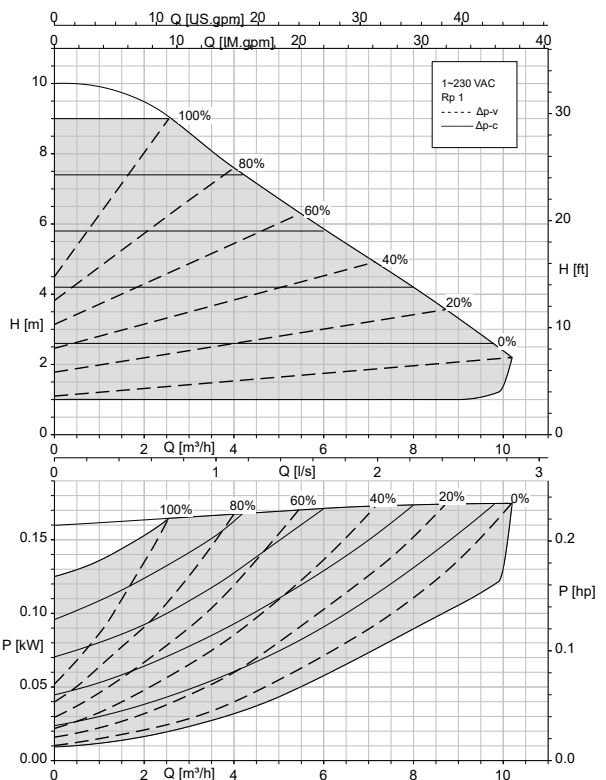

1157.59/10-EN

Calio 30-40 Open-loop Control, Eco Mode

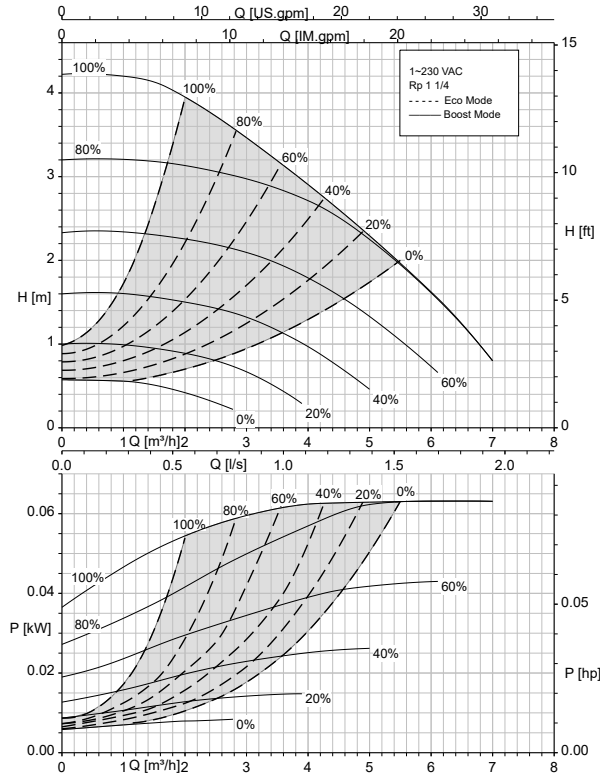

Calio 30-40 Δp_v , Δp_c

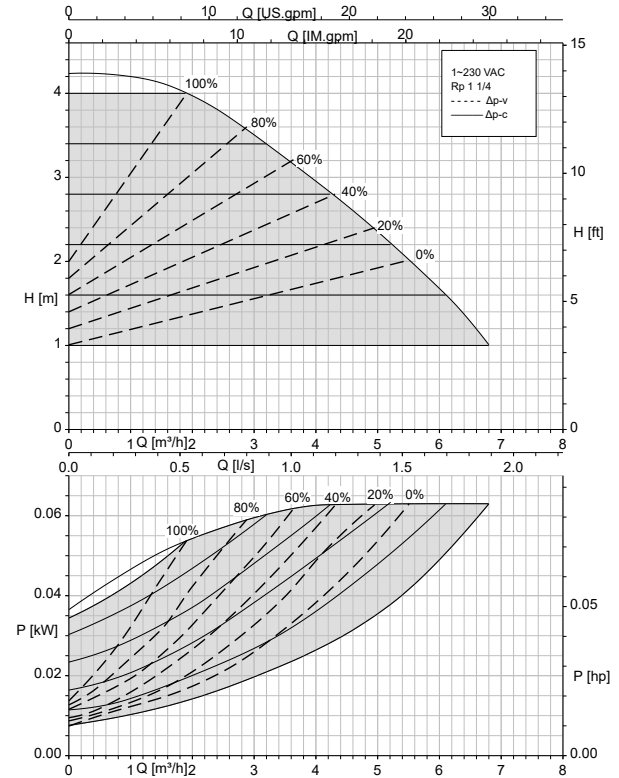

Calio 30-60 Open-loop Control, Eco Mode

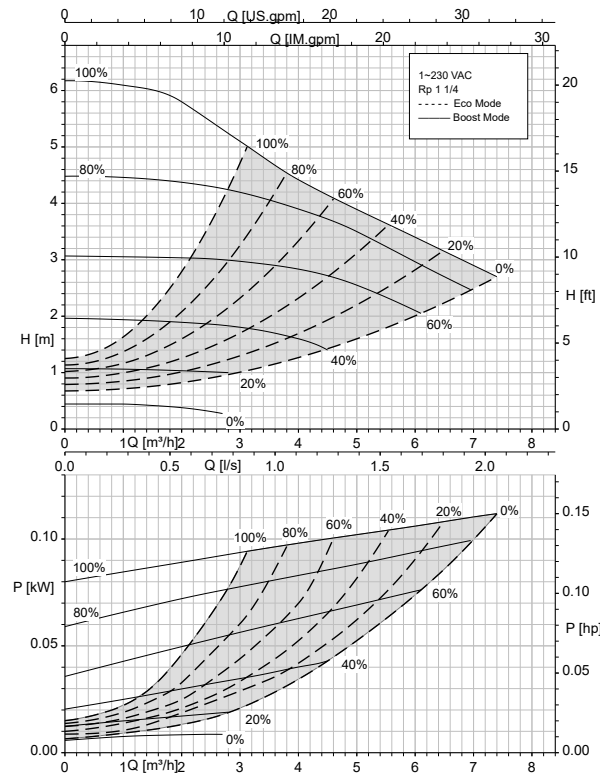

Calio 30-60 Δp_v , Δp_c

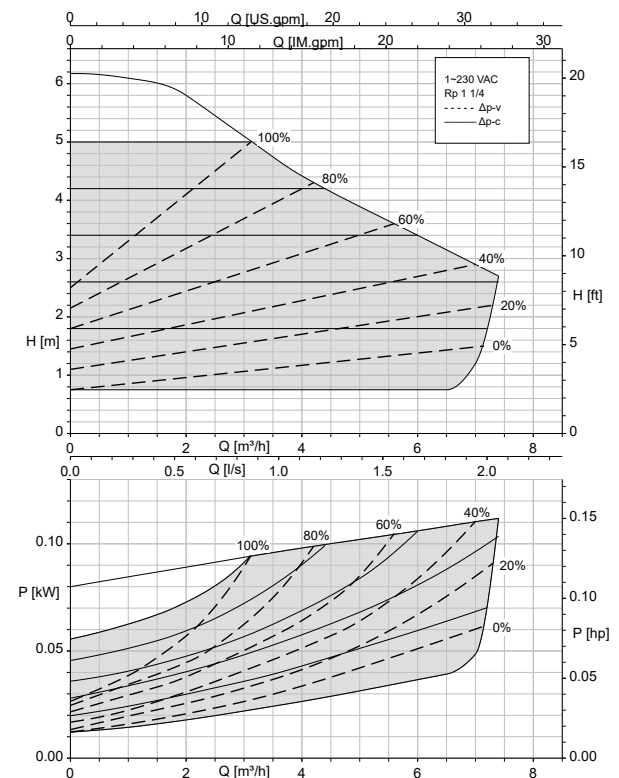

1157.59/10-EN

Calio 30-80 Open-loop Control, Eco Mode

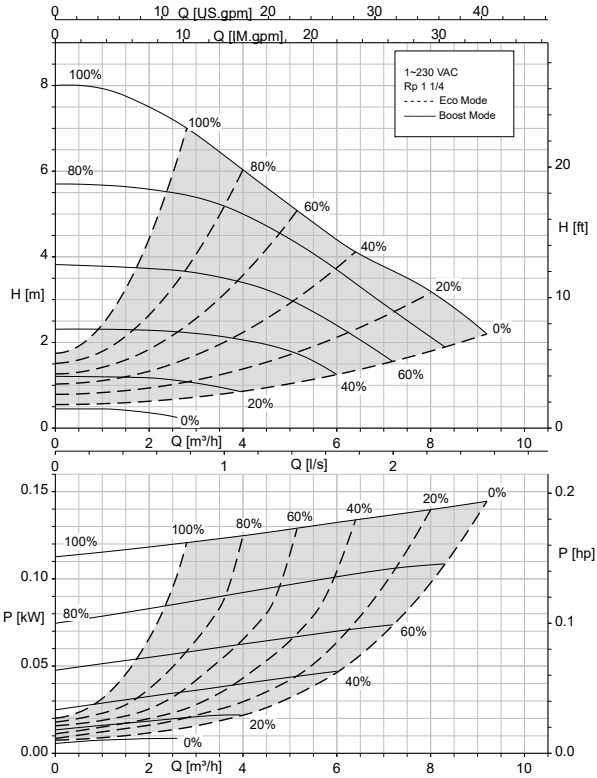

Calio 30-80 Δp_v , Δp_c

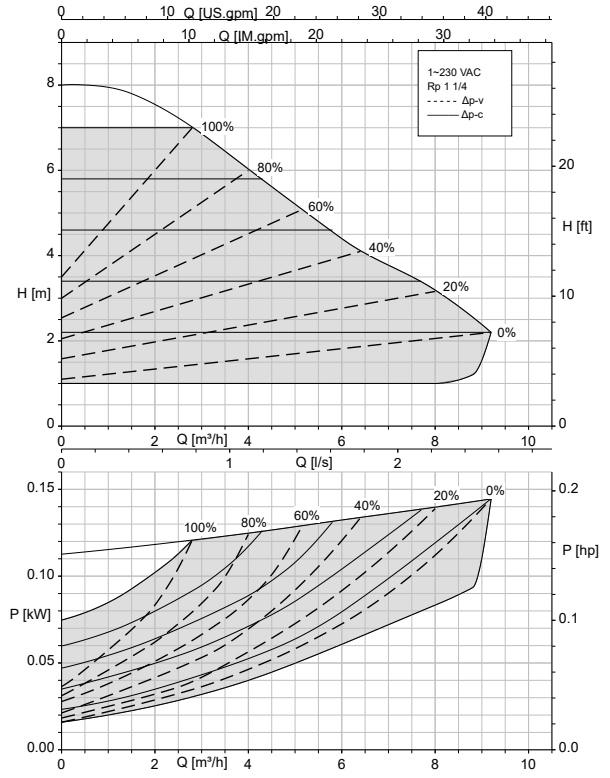

Calio 30-100 Open-loop Control, Eco Mode

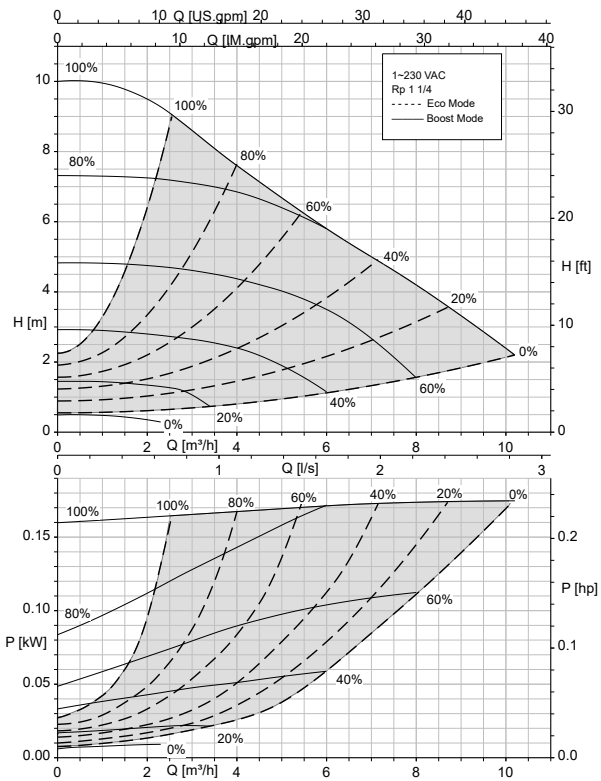

Calio 30-100 Δp_v , Δp_c

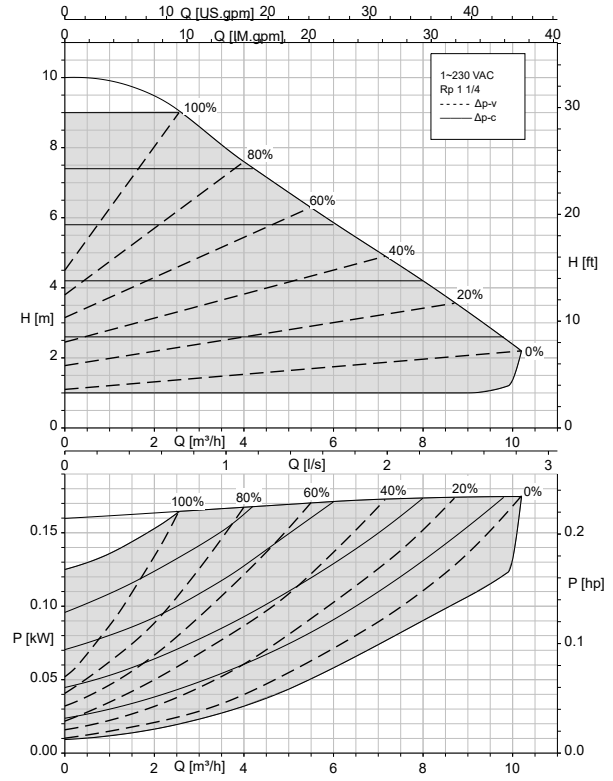

Calio 30-120 Open-loop Control, Eco Mode

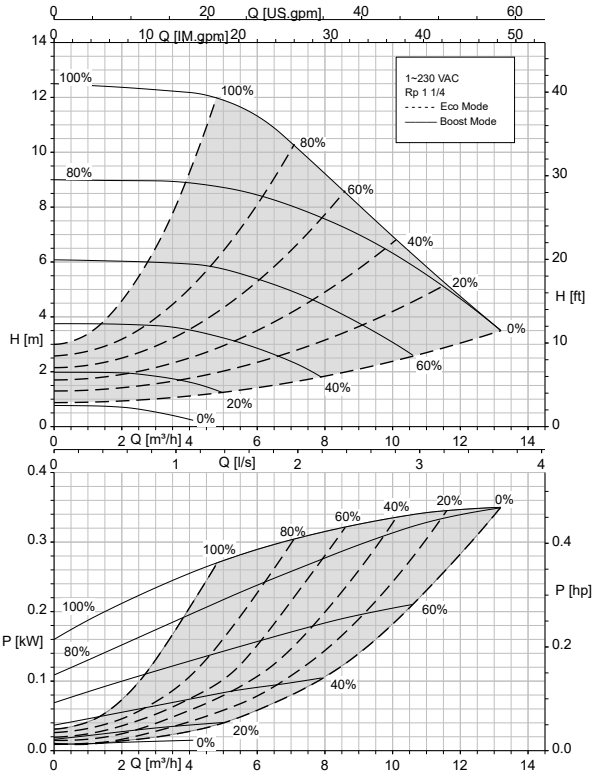

Calio 30-120 Δp_v , Δp_c

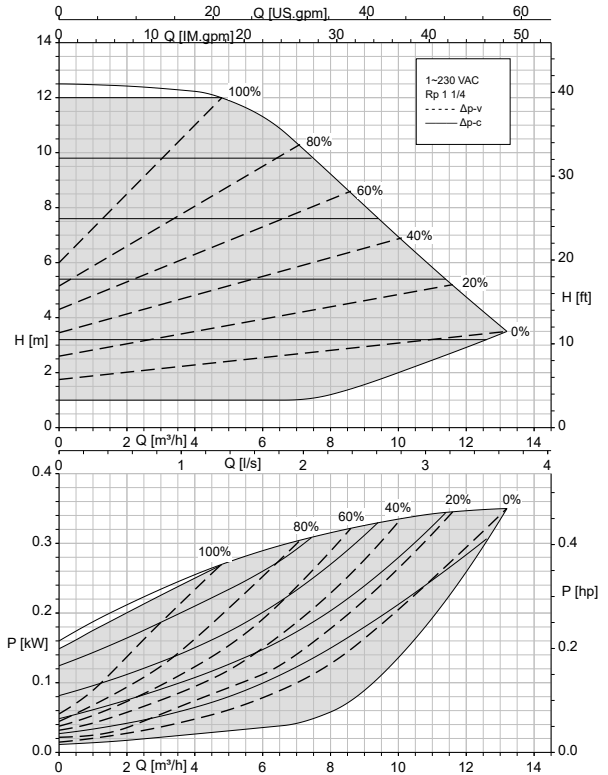

Calio 32-40 Open-loop Control, Eco Mode

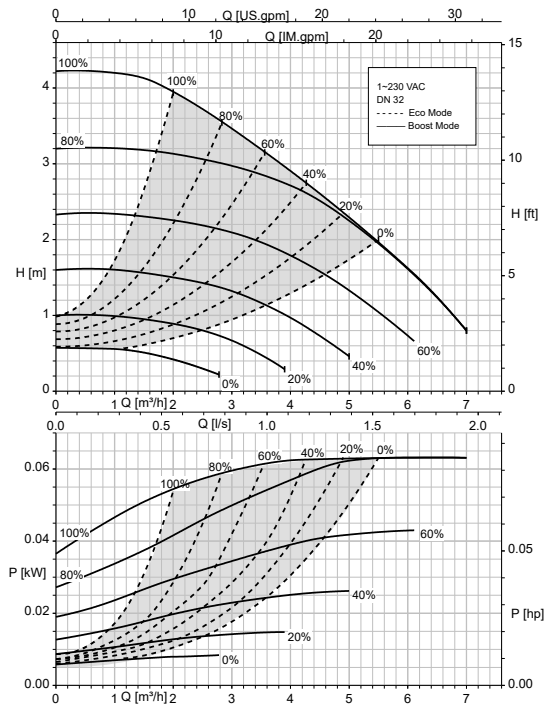

Calio 32-40 Δp_v , Δp_c

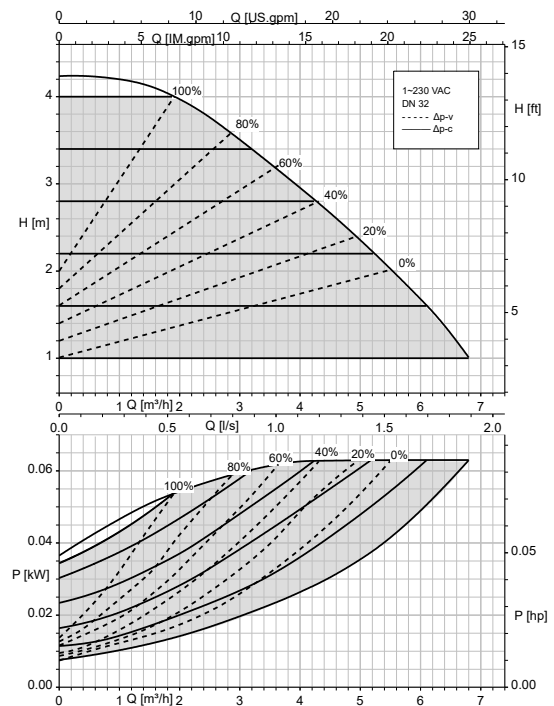

Calio 32-60 Open-loop Control , Eco Mode

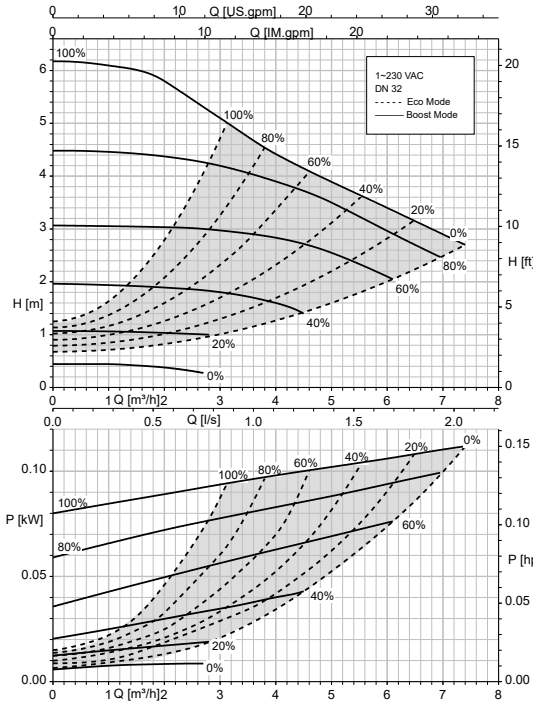

Calio 32-60, $\Delta p-v$, $\Delta p-c$

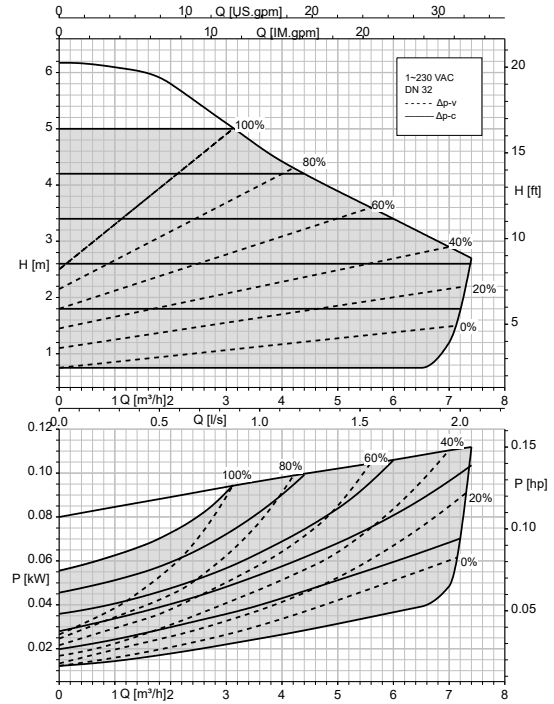

Calio 32-80 Open-loop Control , Eco Mode

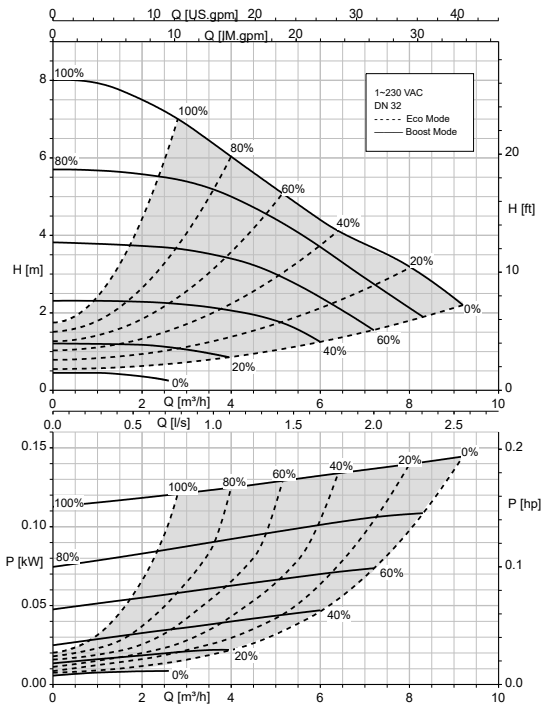

Calio 32-80, $\Delta p-v$, $\Delta p-c$

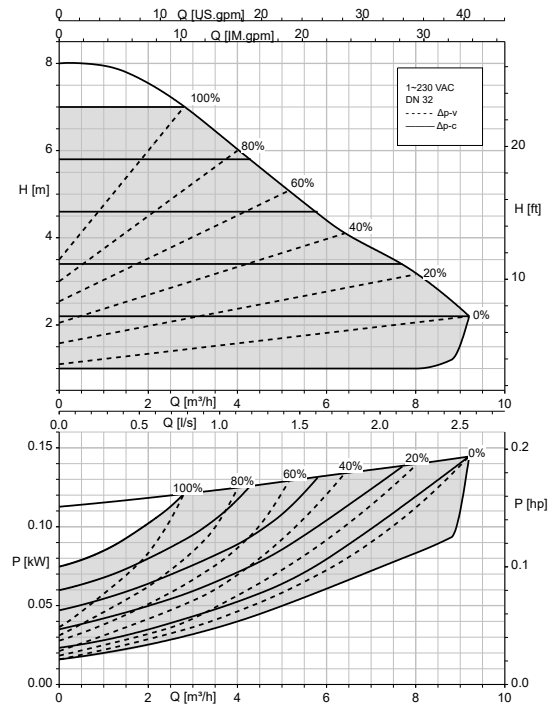

Calio 32-100 Open-loop Control , Eco Mode

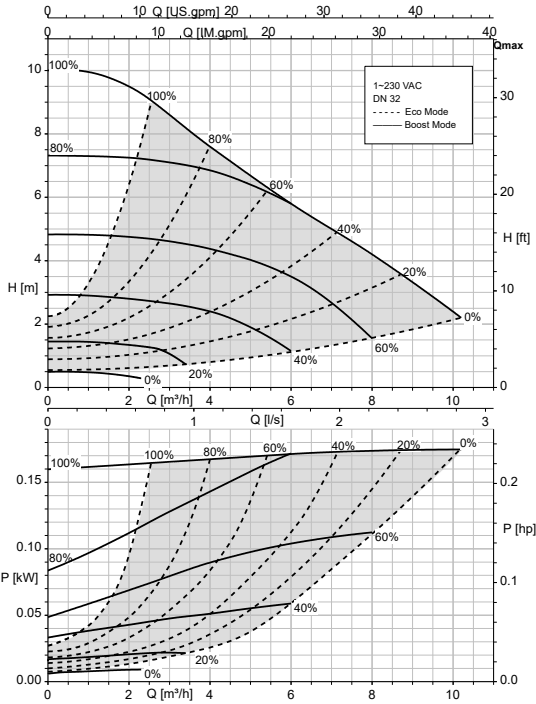

Calio 32-100 $\Delta p-v$, $\Delta p-c$

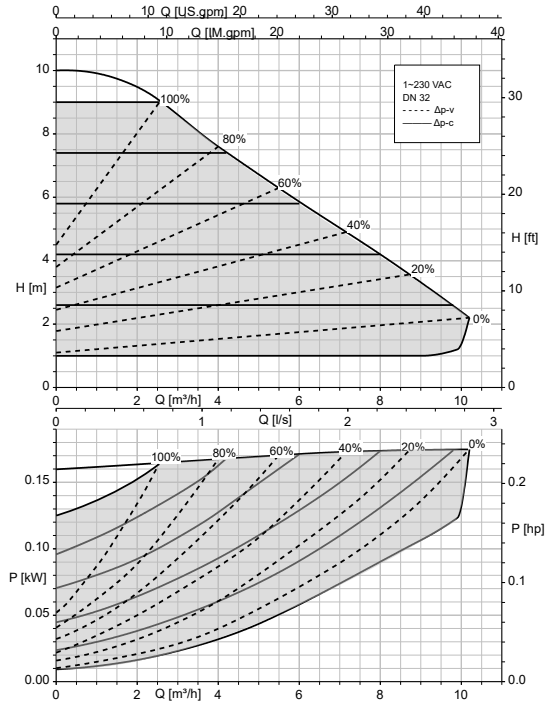

Calio 32-120 Open-loop Control, Eco Mode

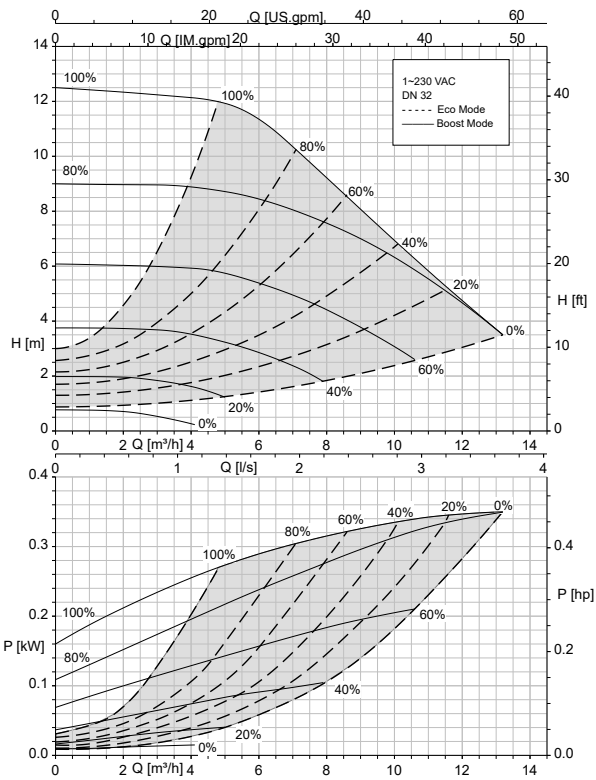

Calio 32-120 Δp_v , Δp_c

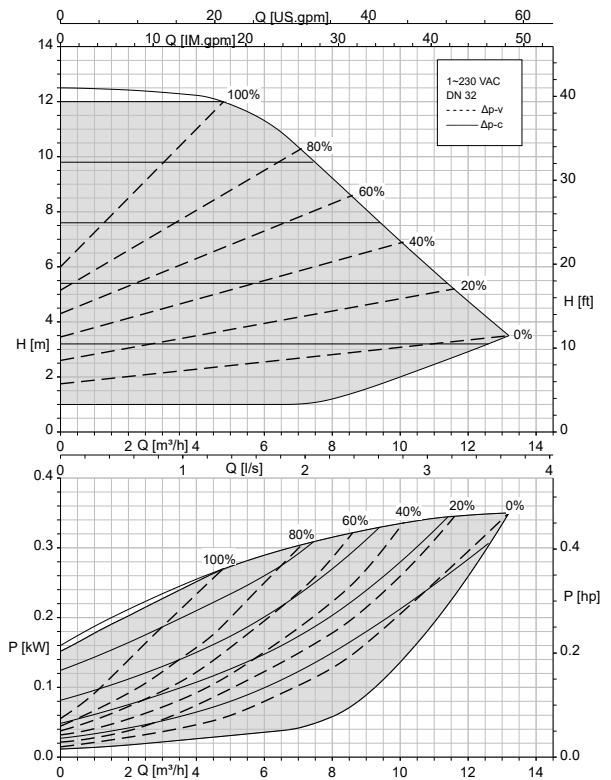

1157.59/10-EN

Calio 40-40 Open-loop Control, Eco Mode

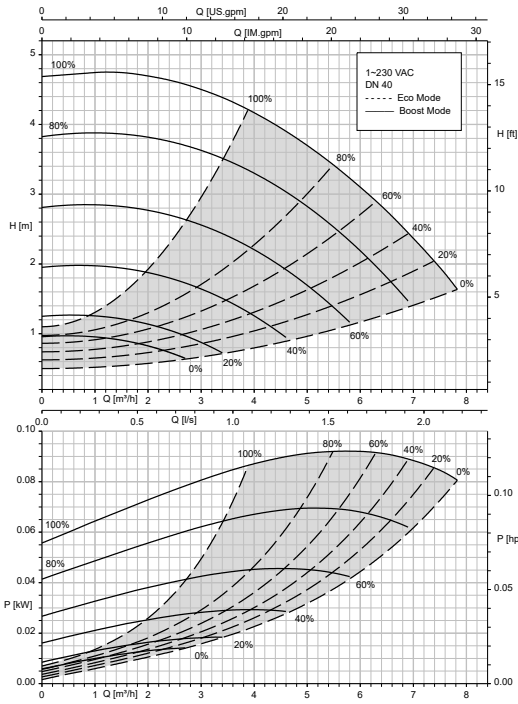

Calio 40-40, $\Delta p-v$, $\Delta p-c$

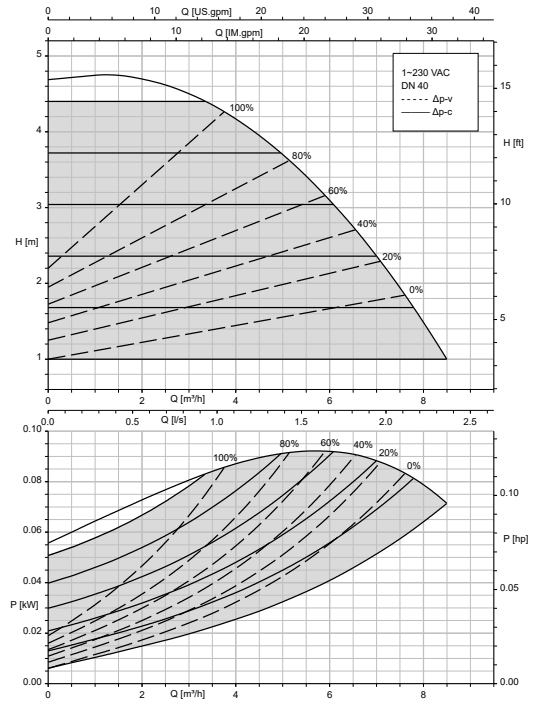

Calio 40-60 Open-loop Control, Eco Mode

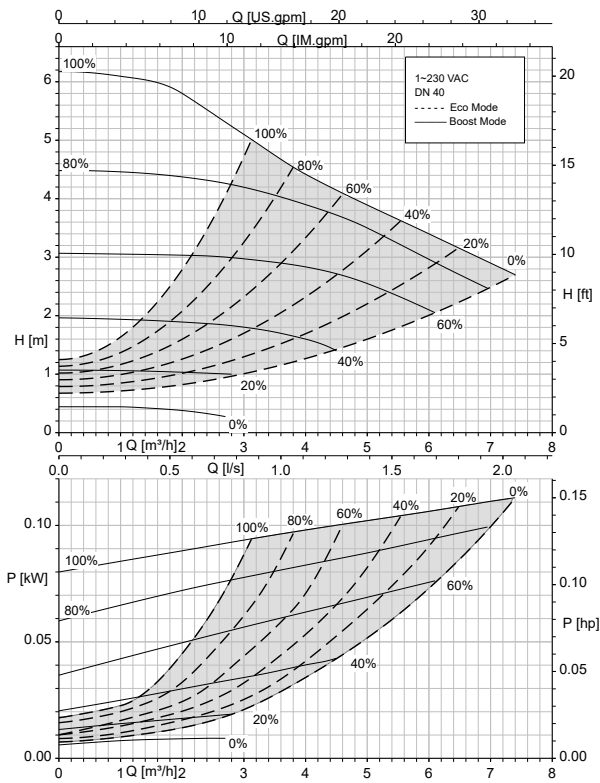

Calio 40-60 Δp_v , Δp_c

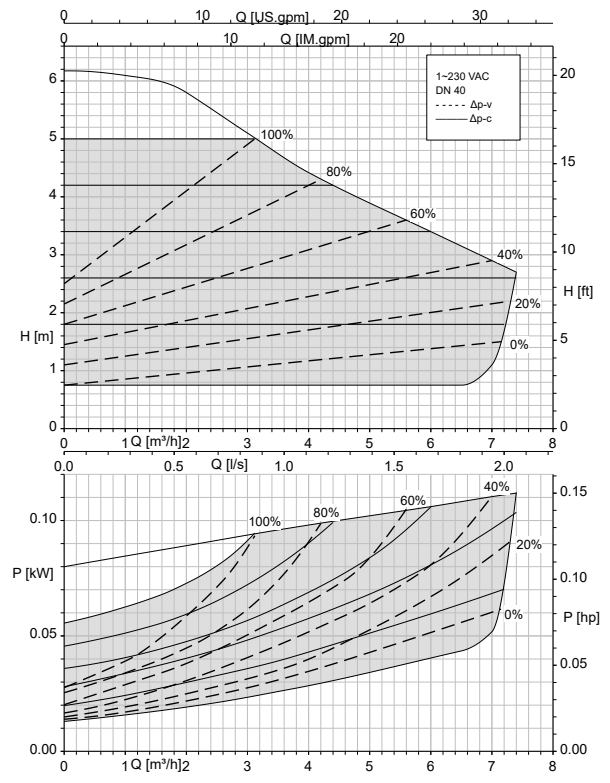

Calio 40-70 Open-loop Control, Eco Mode

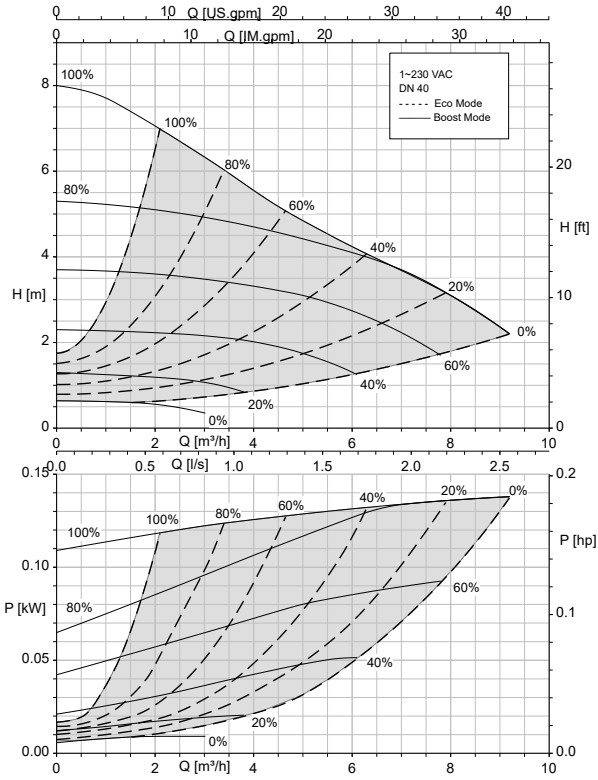

Calio 40-70 Δp_v , Δp_c

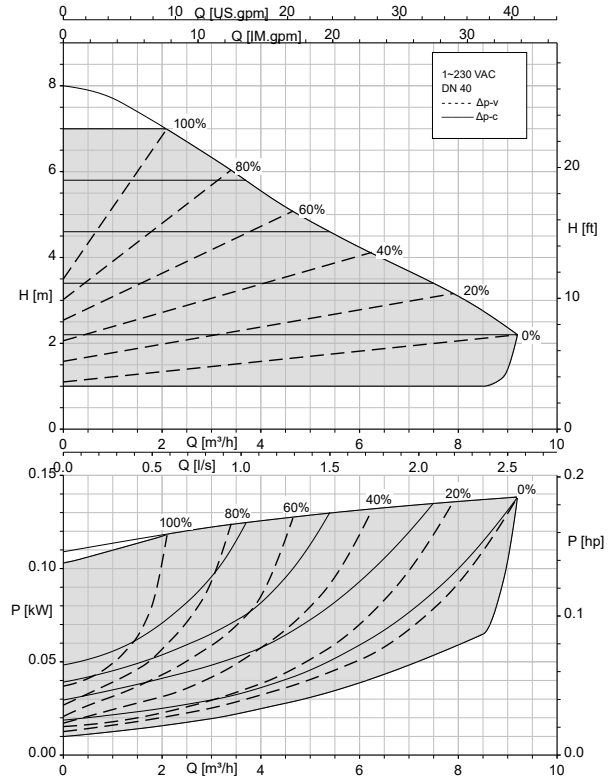

Calio 40-80 Open-loop Control, Eco Mode

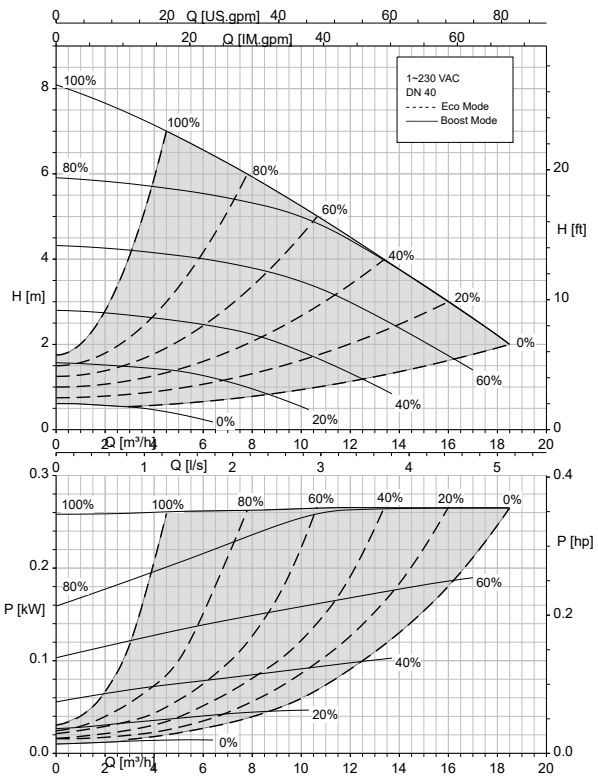

Calio 40-80 Δp_v , Δp_c

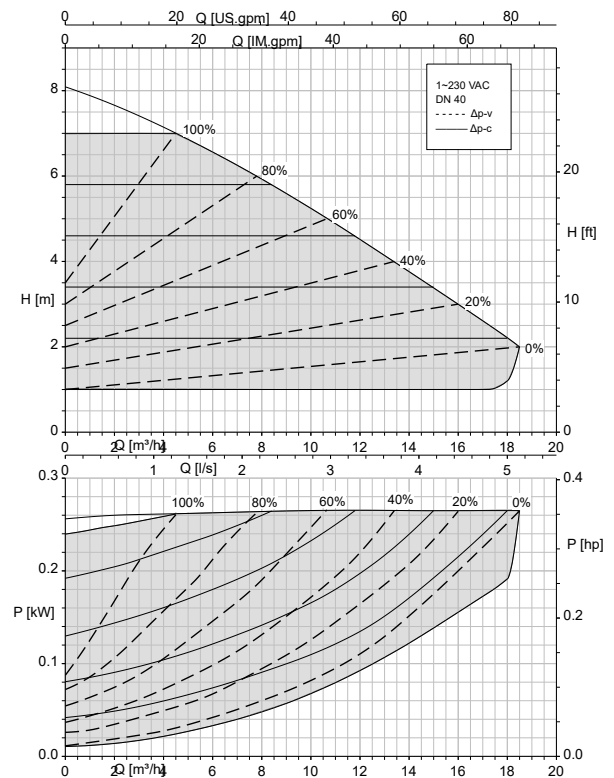

1157.59/10-EN

Calio 40-90 Open-loop Control, Eco Mode

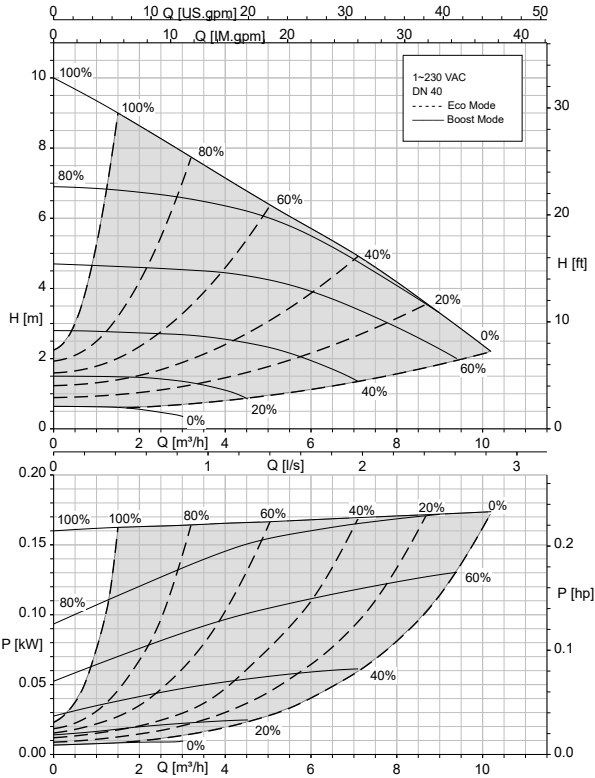

Calio 40-90 Δp_v , Δp_c

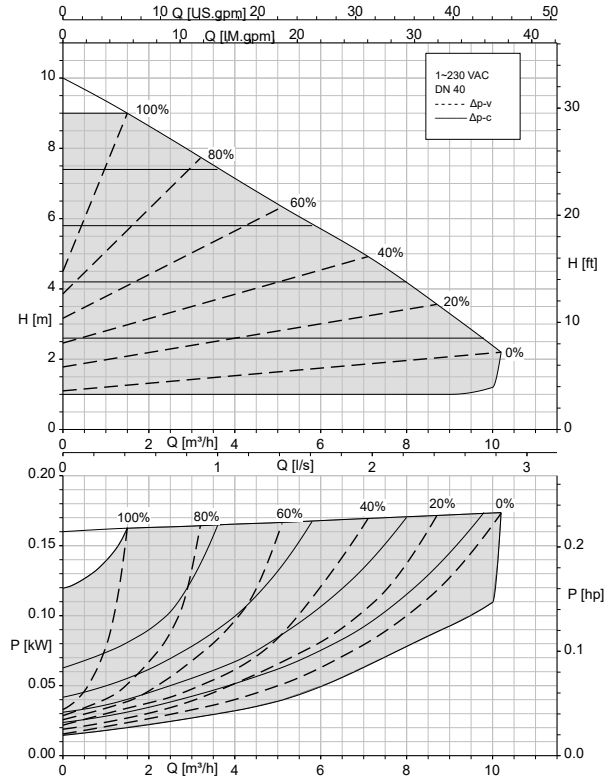

Calio 40-100 Open-loop Control, Eco Mode

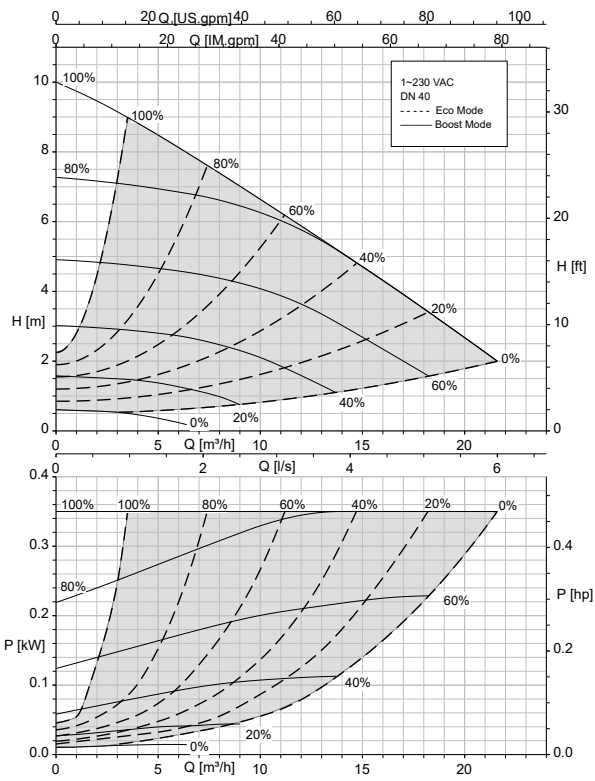

Calio 40-100 Δp_v , Δp_c

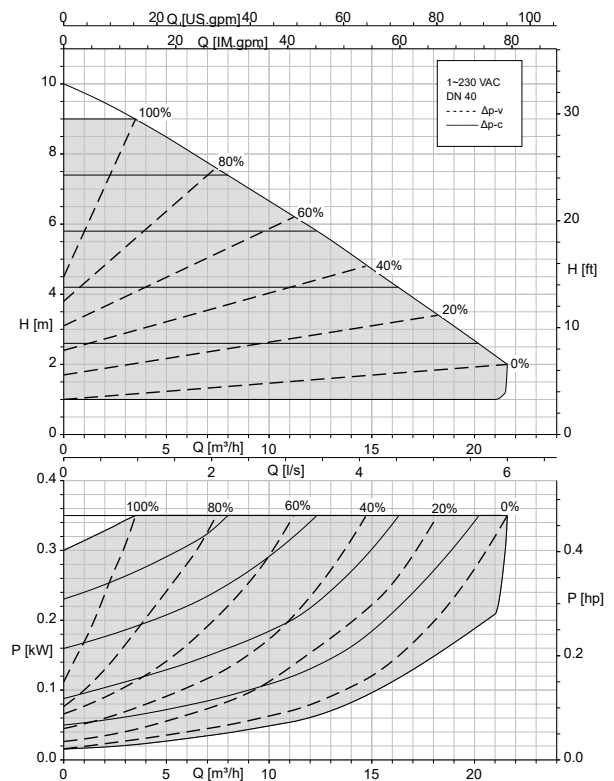

Calio 40-120 Open-loop Control, Eco Mode

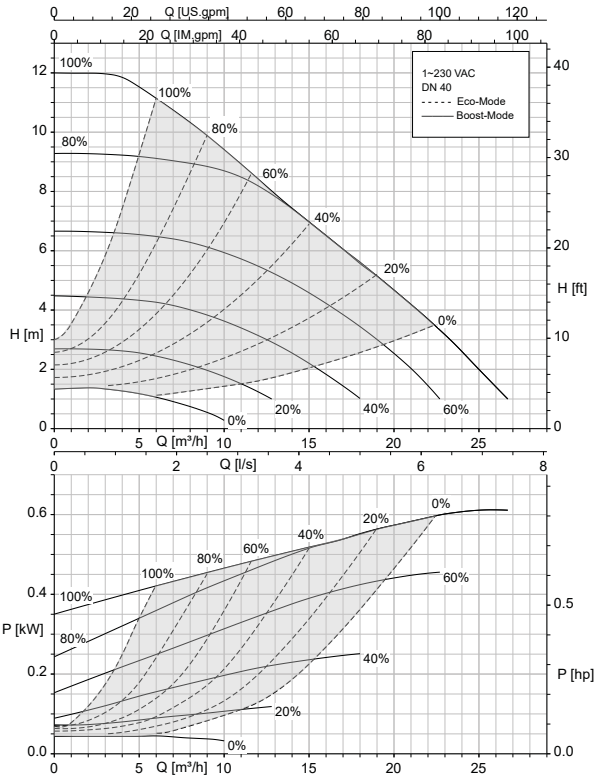

Calio 40-120 Δp -v, Δp -c

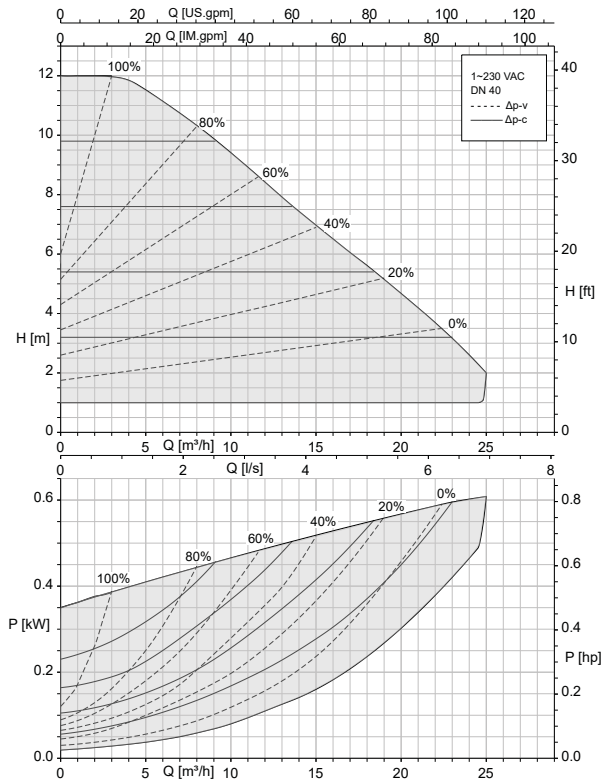

Calio 40-180 Open-loop Control, Eco Mode

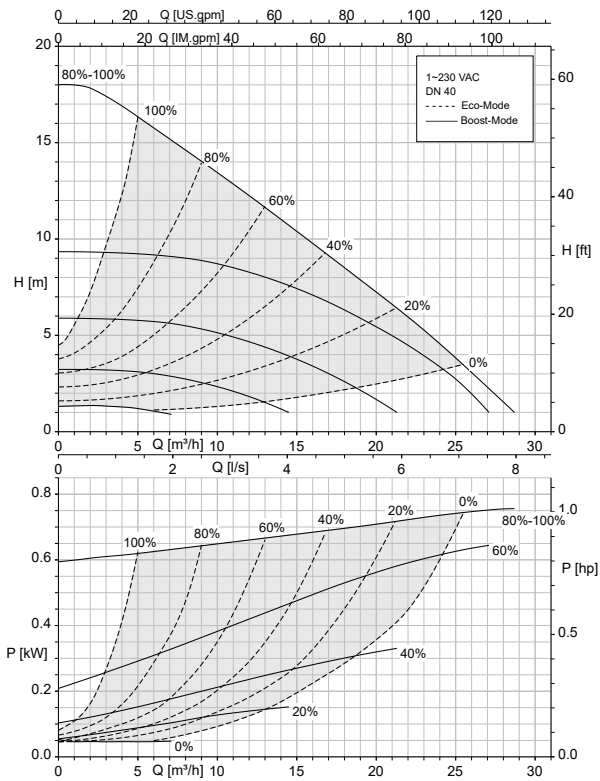

Calio 40-180 Δp -v, Δp -c

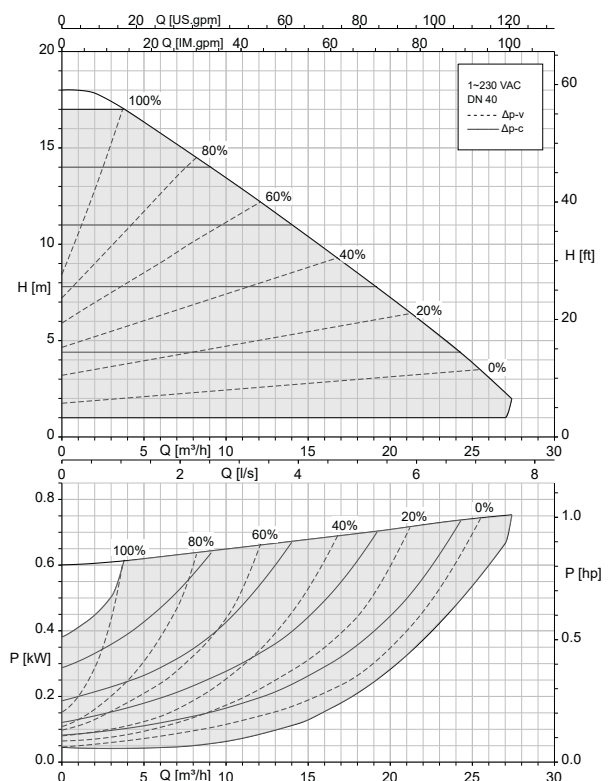

Calio 50-40 Open-loop Control, Eco Mode

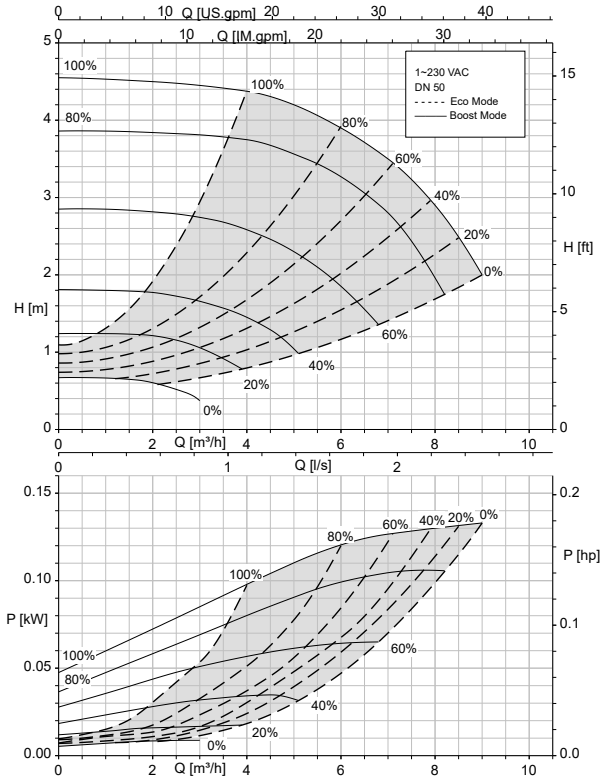

Calio 50-40 Δp_v , Δp_c

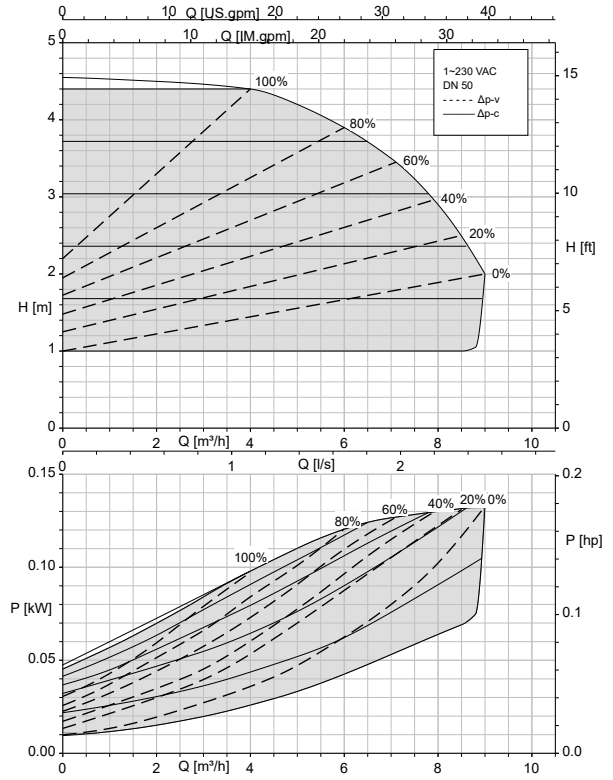

Calio 50-60 Open-loop Control, Eco Mode

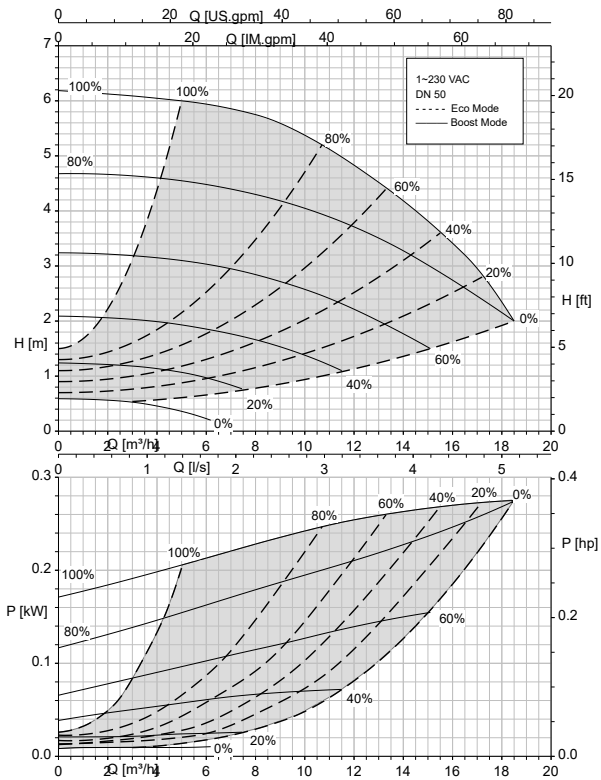

Calio 50-60 Δp_v , Δp_c

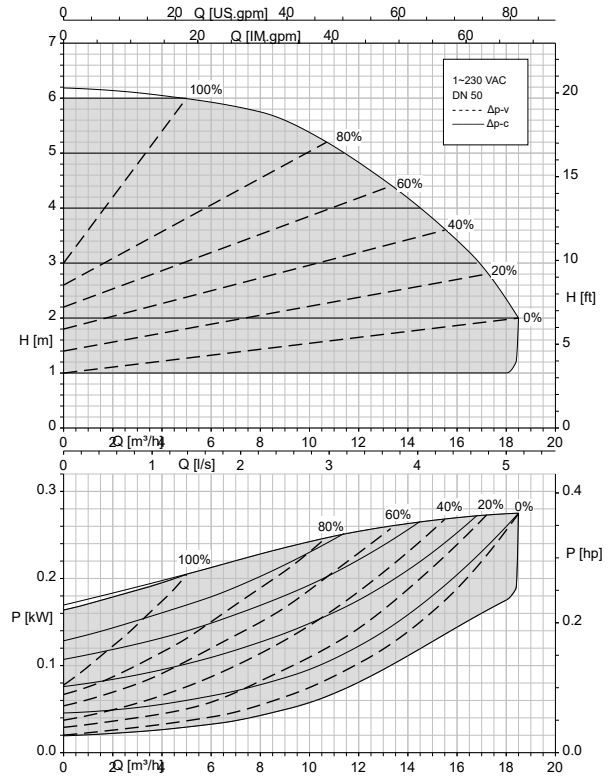

1157.59/10-EN

Calio 50-80 Open-loop Control, Eco Mode

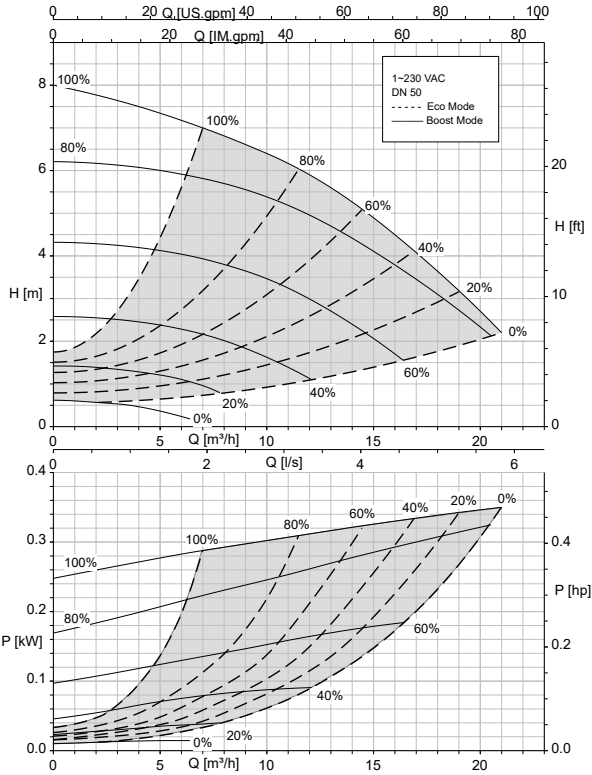

Calio 50-80 Δpv, Δpc

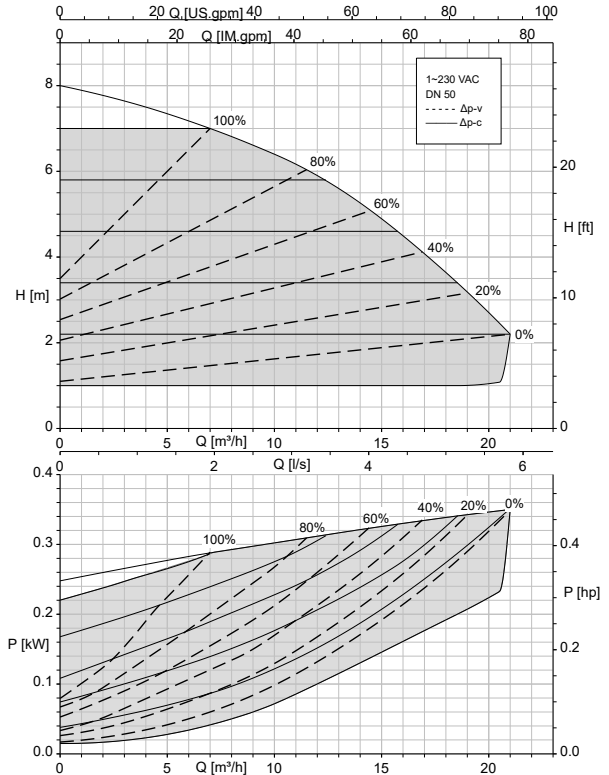

Calio 50-90 Open-loop Control, Eco Mode

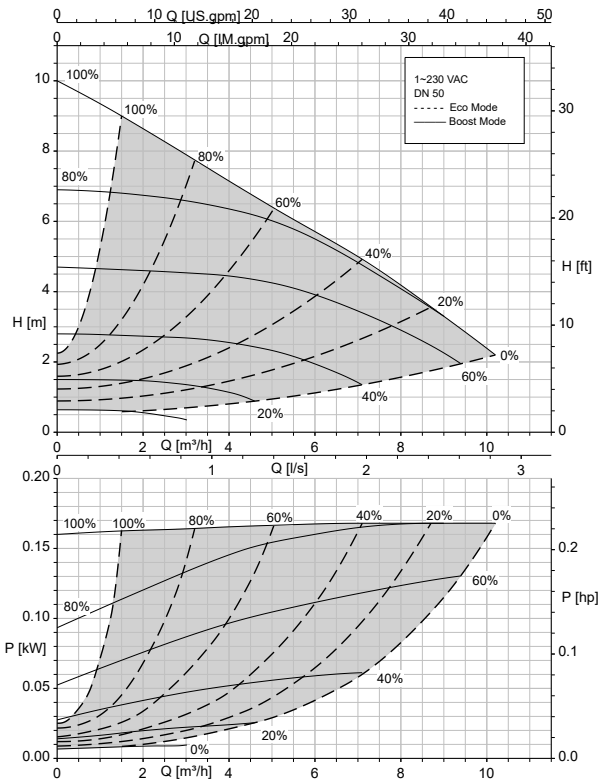

Calio 50-90 Δpv, Δpc

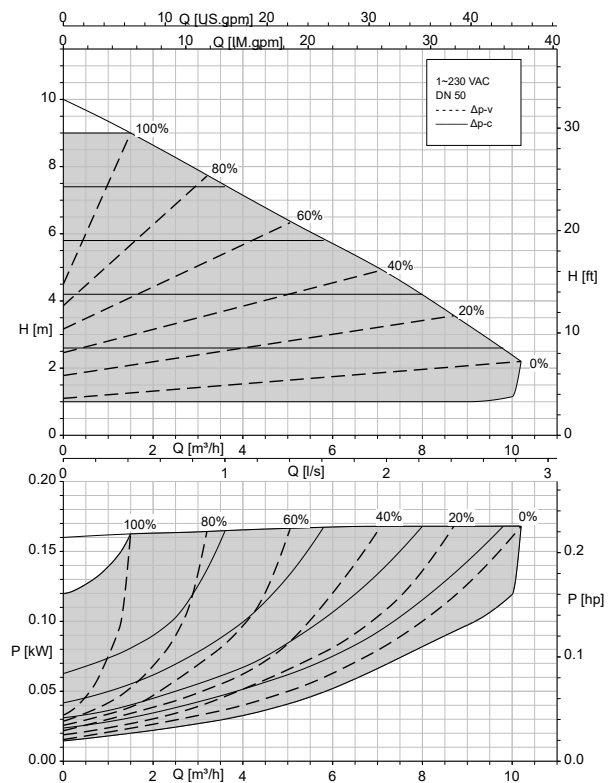

1157.59/10-EN

Calio 50-100 Open-loop Control, Eco Mode

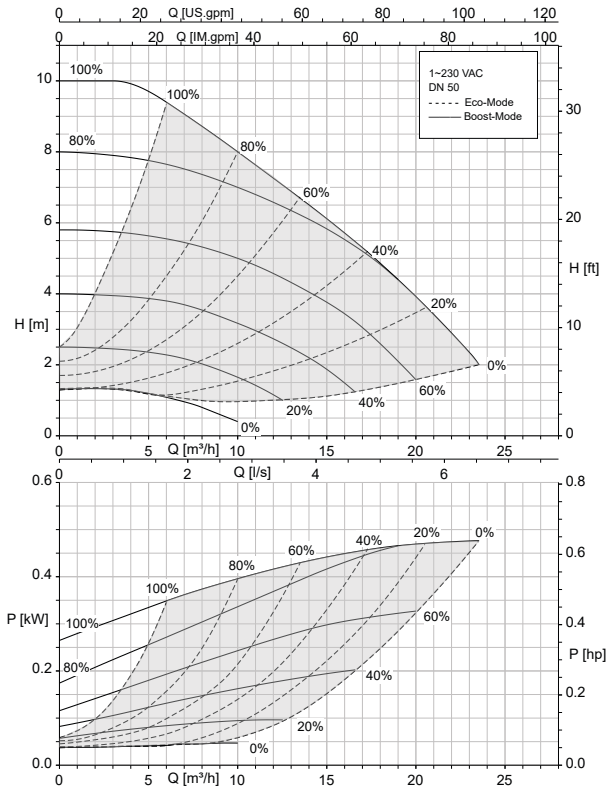

Calio 50-100 Δp -v, Δp -c

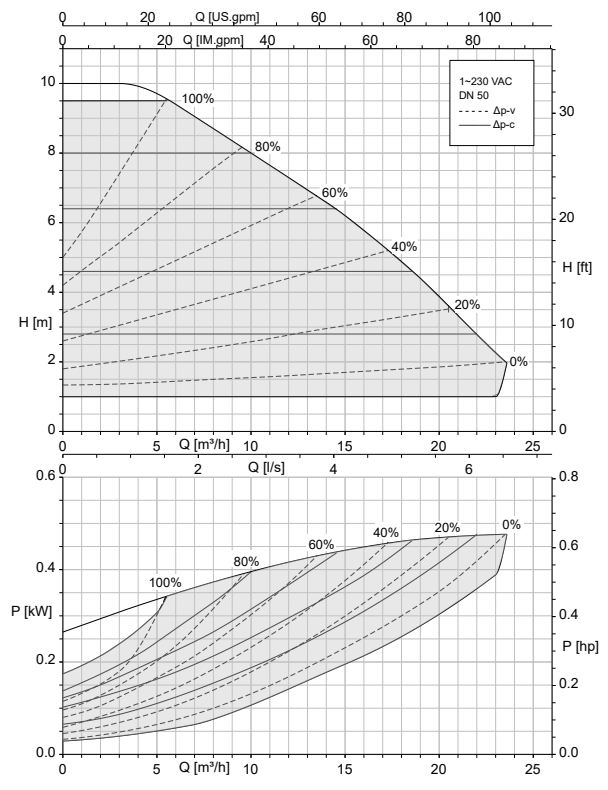

Calio 50-120 Open-loop Control, Eco Mode

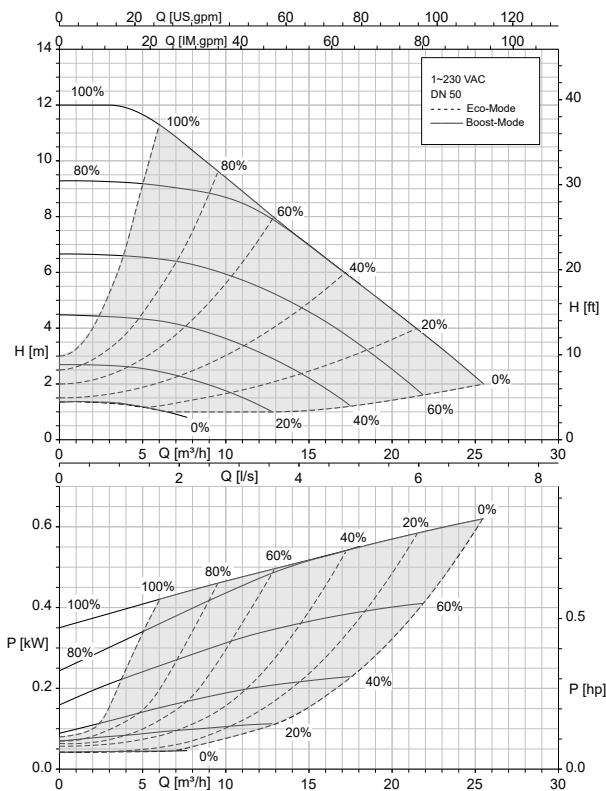

Calio 50-120 Δp -v, Δp -c

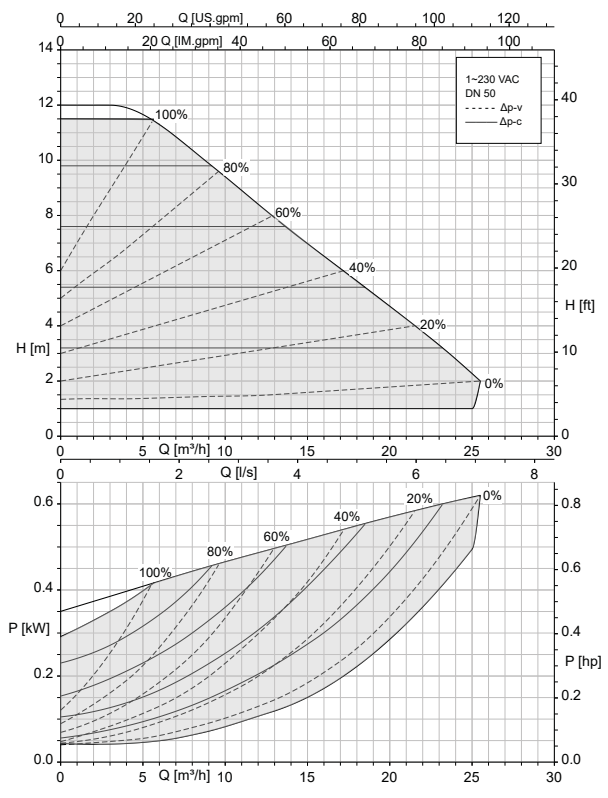

Calio 50-150 Open-loop Control, Eco Mode

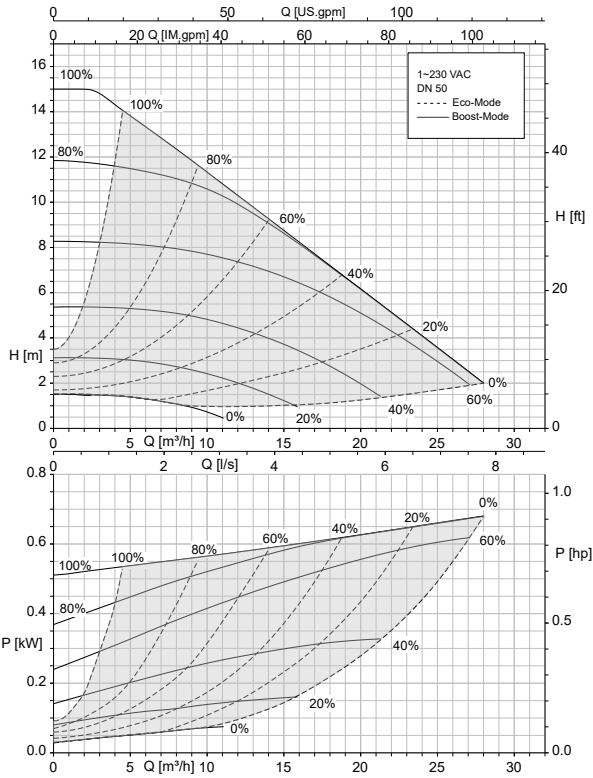

Calio 50-150 Δp -v, Δp -c

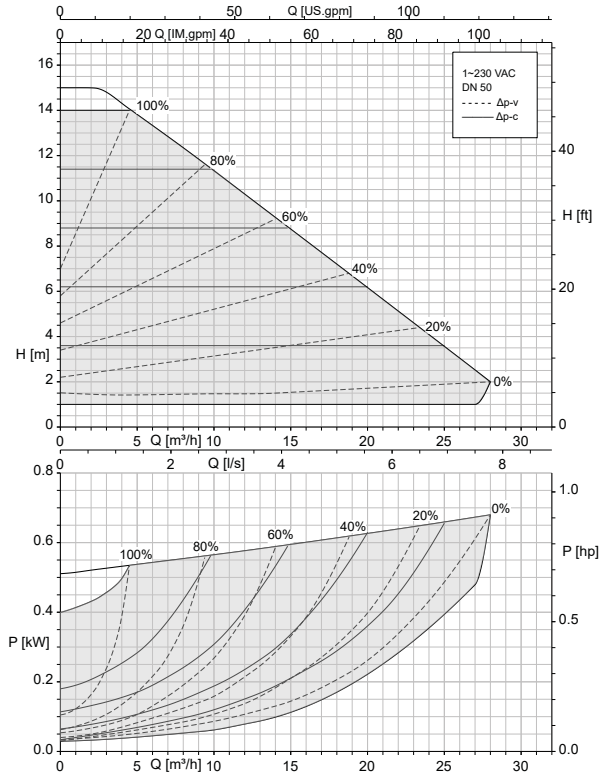

Calio 50-180 Open-loop Control, Eco Mode

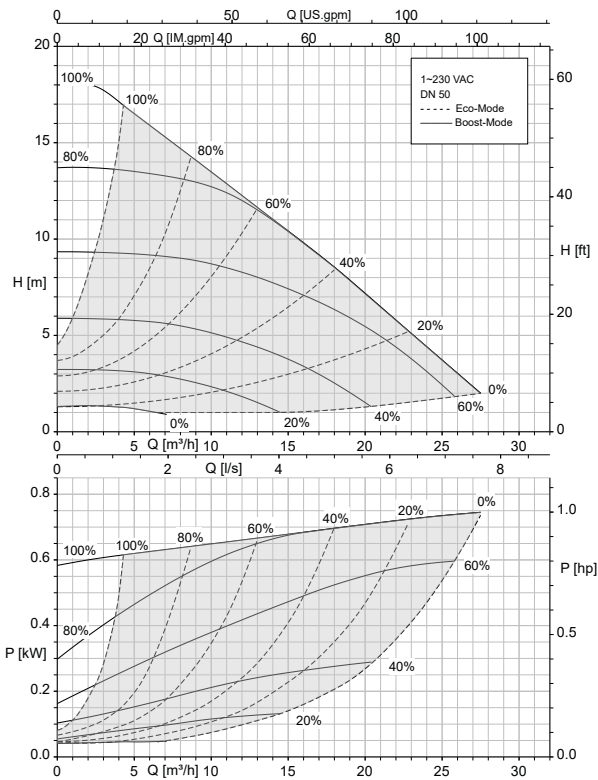

Calio 50-180 Δp -v, Δp -c

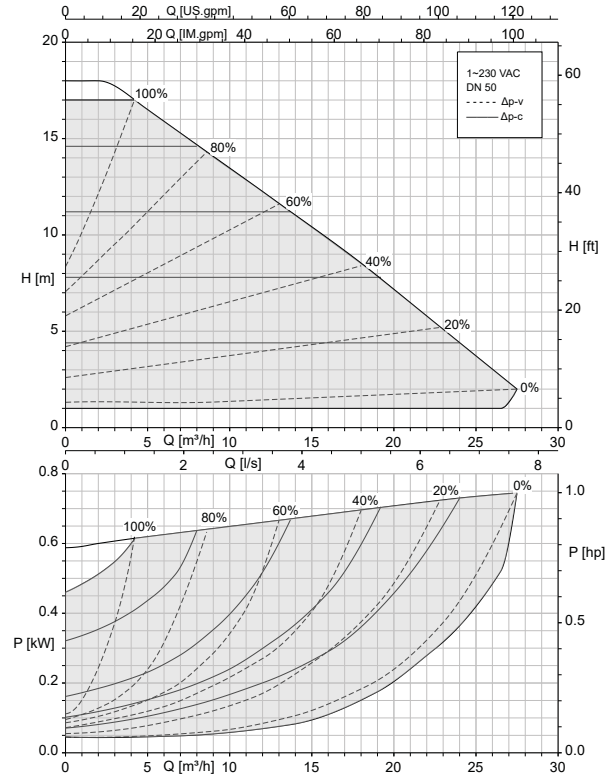

Calio 65-60 Open-loop Control, Eco Mode

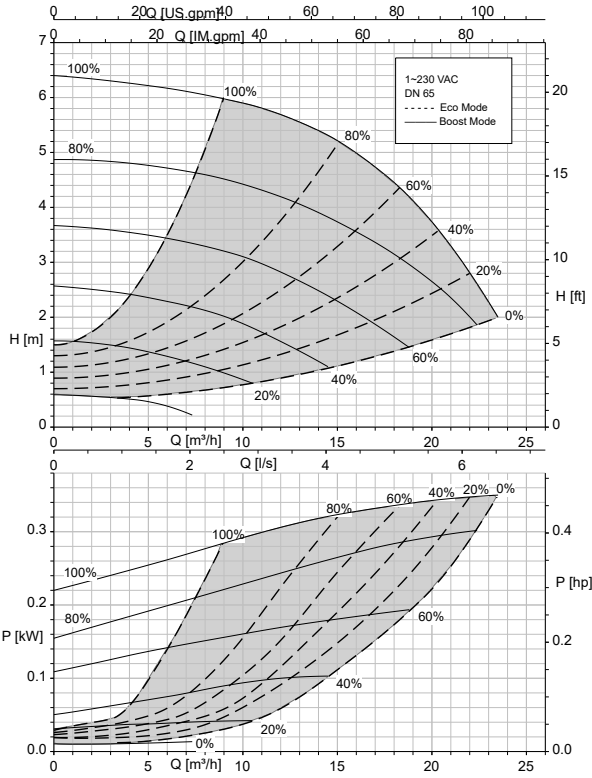

Calio 65-60 Δp_v , Δp_c

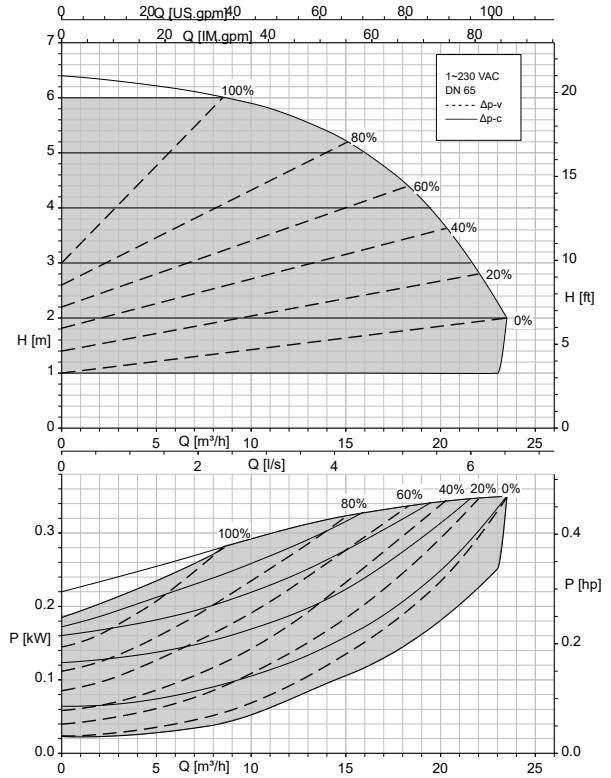

Calio 65-120 Open-loop Control, Eco Mode

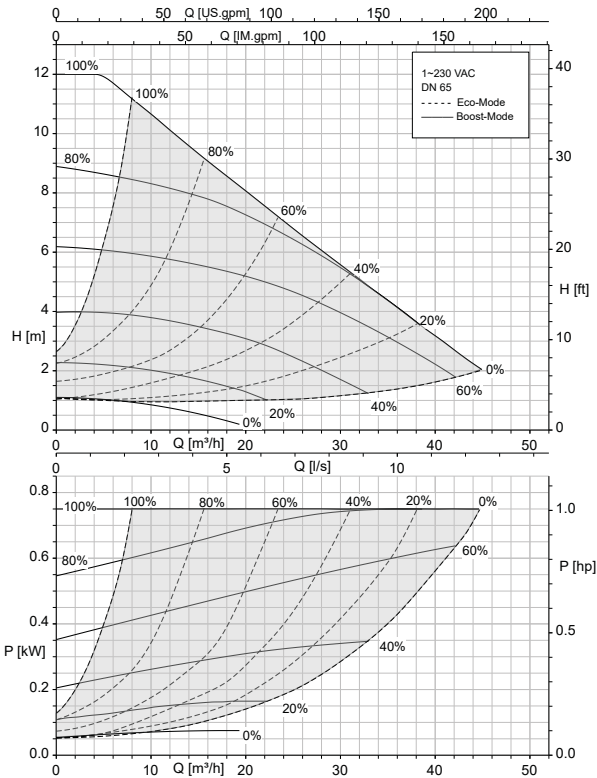

Calio 65-120 Δp_v , Δp_c

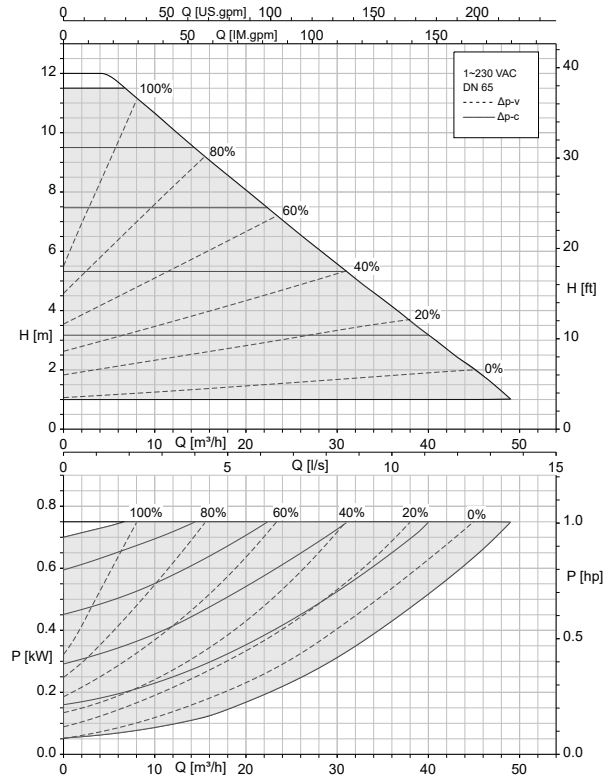

Calio 80-80 Open-loop Control, Eco Mode

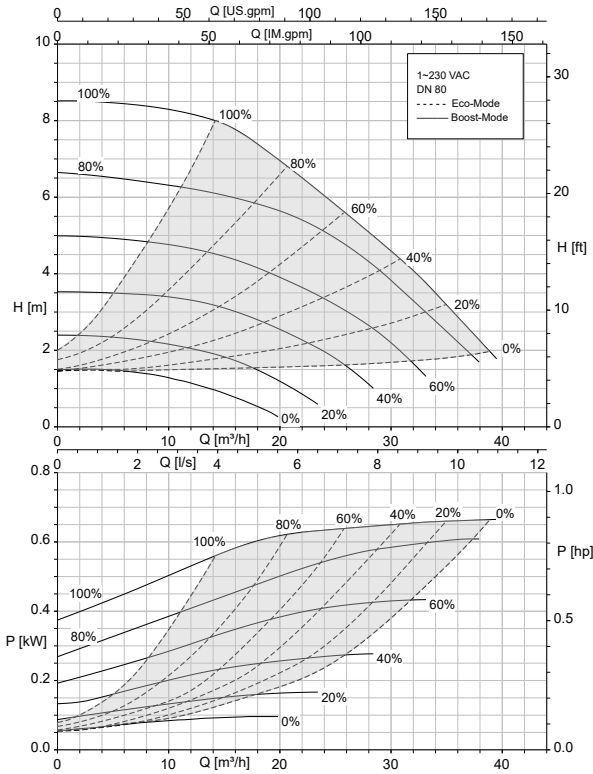

Calio 80-80 $\Delta p-v$, $\Delta p-c$

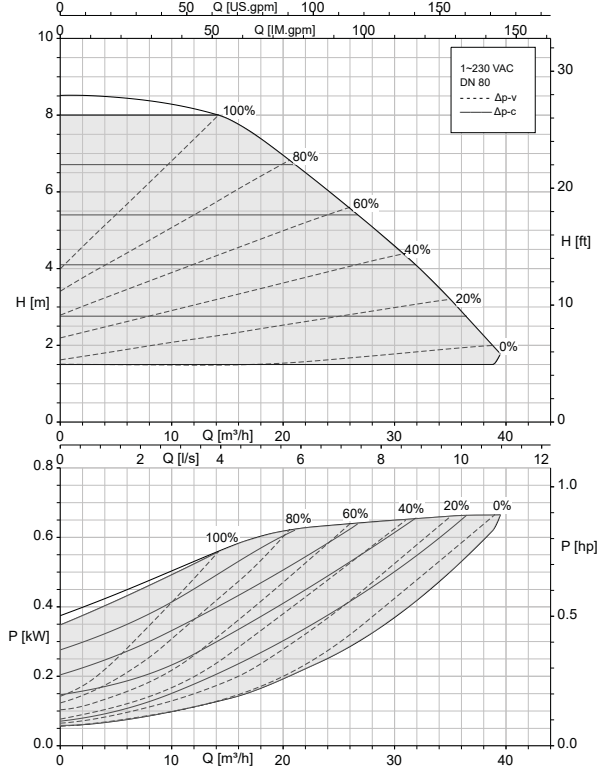

Calio 100-60 Open-loop Control, Eco Mode

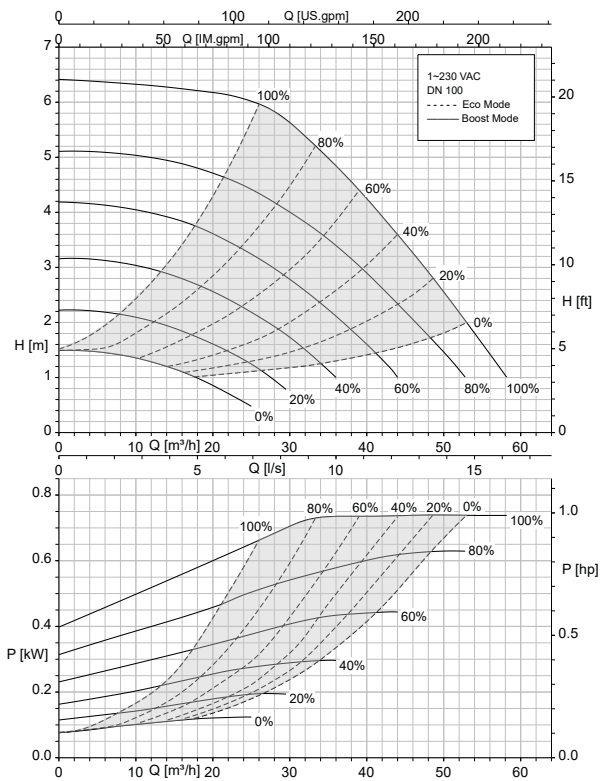

Calio 100-60 $\Delta p-v$, $\Delta p-c$

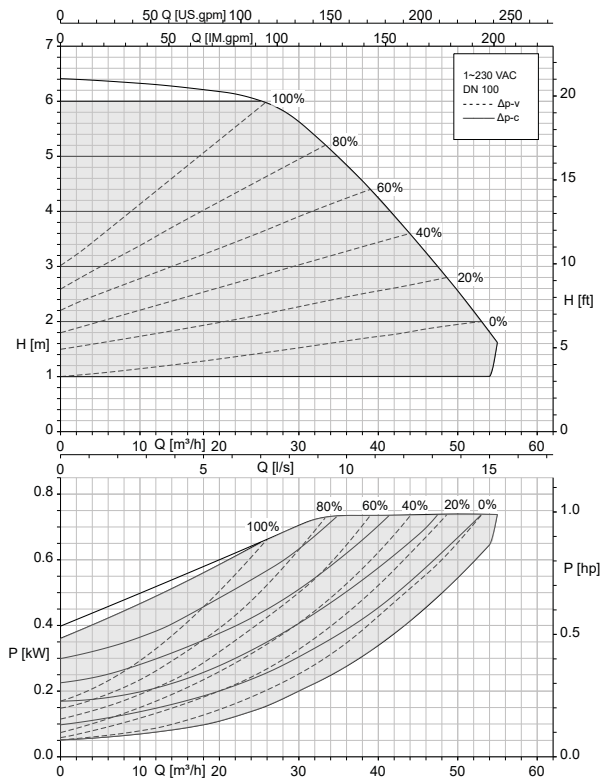

1157.59/10-EN

Dimensions

Pump set dimensions

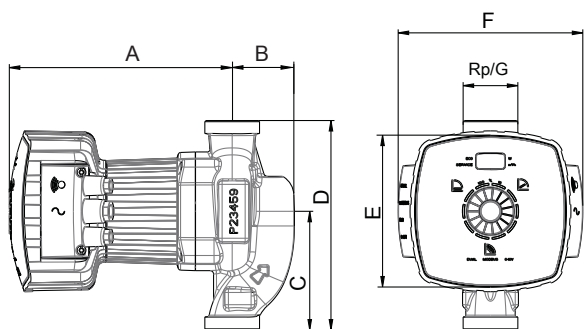

Fig. 4: Screw-ended pump set

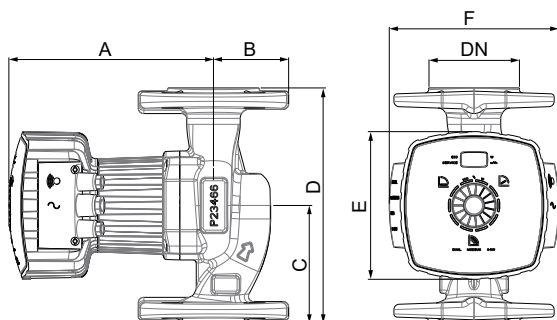

Fig. 5: Flanged pump set

Table 10: Pump set dimensions

Size	Connection			A [mm]	B [mm]	C [mm]	D [mm]	E [mm]	F [mm]
	R	G	DN						
25-40	1	1 1/2	-	197	56	98	180	137	172
25-60	1	1 1/2	-	197	56	98	180	137	172
25-80	1	1 1/2	-	197	56	98	180	137	172
25-100	1	1 1/2	-	197	56	98	180	137	172
30-40	1 1/4	2	-	197	56	98	180	137	172
30-60	1 1/4	2	-	197	56	98	180	137	172
30-80	1 1/4	2	-	197	56	98	180	137	172
30-100	1 1/4	2	-	197	56	98	180	137	172
30-120	1 1/4	2	-	232	56	98	180	137	172
32-40	-	-	32	205	65	110	220	137	172
32-60	-	-	32	205	65	110	220	137	172
32-80	-	-	32	205	65	110	220	137	172
32-100	-	-	32	205	65	110	220	137	172
32-120	-	-	32	232	65	110	220	137	172
40-40	-	-	40	179	70	110	220	137	172
40-60	-	-	40	179	70	110	220	137	172
40-70	-	-	40	179	70	110	220	137	172
40-80	-	-	40	242	70	120	220	137	172
40-90	-	-	40	179	70	110	220	137	172
40-100	-	-	40	242	70	120	220	137	172
40-120	-	-	40	390	75	135	250	206	240
40-180	-	-	40	390	75	135	250	206	240
50-40	-	-	50	179	78	120	240	137	172
50-60	-	-	50	243	78	130	240	137	172
50-80	-	-	50	243	78	130	240	137	172
50-90	-	-	50	179	78	120	240	137	172
50-100	-	-	50	390	77	140	280	206	240
50-120	-	-	50	390	77	140	280	206	240
50-150	-	-	50	390	77	140	280	206	240

1157.59/10-EN

Size	Connection			A	B	C	D	E	F
	R	G	DN	[mm]	[mm]	[mm]	[mm]	[mm]	[mm]
50-180	-	-	50	390	77	140	280	206	240
65-60	-	-	65	244	89	170	340	137	172
65-120	-	-	65	395	95	170	340	206	240
80-80	-	-	80	395	105	170	360	206	240
100-60	-	-	100	395	110	210	450	206	240

Flange dimensions

Table 11: Flange dimensions

Size	PN 6			PN 10, PN 16			Outline drawing
	$\varnothing D$	$\varnothing k$	$n \times \varnothing d_2$	$\varnothing D$	$\varnothing k$	$n \times \varnothing d_2$	
	[mm]	[mm]	[mm]	[mm]	[mm]	[mm]	
DN 32	120	90	4 x $\varnothing 14$	140	100	4 x $\varnothing 19$	
DN 40	130	100	4 x $\varnothing 14$	150	110	4 x $\varnothing 19$	
DN 50	140	110	4 x $\varnothing 14$	165	125	4 x $\varnothing 19$	
DN 65	160	130	4 x $\varnothing 14$	185	145	4 x $\varnothing 19$	
DN 80	190	150	4 x $\varnothing 19$	200	160	8 x $\varnothing 19$	
DN 100	210	170	4 x $\varnothing 19$	220	180	8 x $\varnothing 19$	

Installation information

Permissible installation positions

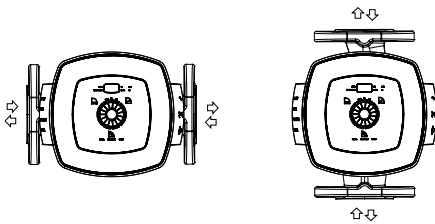



Fig. 6: Permissible installation positions

Scope of supply



Depending on the model, the following items are included in the scope of supply:

- Pump set
- Two-piece thermal insulation shell
- Gaskets
- Washers
- Installation/operating manual

Accessories
Electrical accessories
Table 12: Overview of electrical accessories

	Description	Mat. No.	[kg]
	BACnet MS/TP communication module Suitable for mounting in a control cabinet, for connecting 1 Calio / CalioTherm Pro pump	18041730	0,1

Pipe unions
Table 13: Pipe unions

	Description	Mat. No.	[kg]
	2 pipe unions with G 1 1/2 union nut and insert with Rp 3/4 internal thread, steel for pumps with G 1 1/2 external thread / Rp 3/4 pipe connection	19075560	0,2
	2 pipe unions with G 1 1/2 union nut and insert with Rp 1 internal thread, steel for pumps with G 1 1/2 external thread / Rp 1 pipe connection	19075561	0,2
	2 pipe unions with G 2 union nut and insert with Rp 1 1/4 internal thread, steel for pumps with G 2 external thread / Rp 1 1/4 pipe connection	19075562	0,2

Spacers (flange)

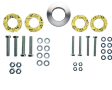
	Description	Connection	PN	Length	Mat. No.	[kg]
		Flange		[mm]		
	Spacer F16	DN 40	6/10/16	30	19075991	2
	Spacer F0	DN 40	6/10/16	70	19075566	2
	Spacer F1	DN 50	6/10/16	10	19075567	2
	Spacer F2	DN 50	6/10/16	20	19075568	2
	Spacer F3	DN 50	6/10/16	50	19075569	2
	Spacer F4	DN 50	6/10/16	60	19075570	2
	Spacer F5	DN 65	6/10/16	10	19075571	2
	Spacer F6	DN 65	6/10/16	25	19075572	2
	Spacer F7	DN 65	6/10/16	30	19075573	2
	Spacer F8	DN 80	6/10/16	10	19075574	2
	Spacer F9	DN 80	6/10/16	15	19075575	2
	Spacer F10	DN 80	6/10/16	20	19075576	2
	Spacer F11	DN 80	6/10/16	25	19075577	2
	Spacer F12	DN 80	6/10/16	30	19075578	2
	Spacer F13	DN 80	6/10/16	40	19075579	2
Spacer F14	DN 80	6/10/16	50	19075580	2	
Spacer F15	DN 80	6/10/16	80	19075581	2	



KSB SE & Co. KGaA
Johann-Klein-Straße 9 • 67227 Frankenthal (Germany)
Tel. +49 6233 86-0
www.ksb.com