

HDA Horizontal multi-stage high pressure centrifugal pumps

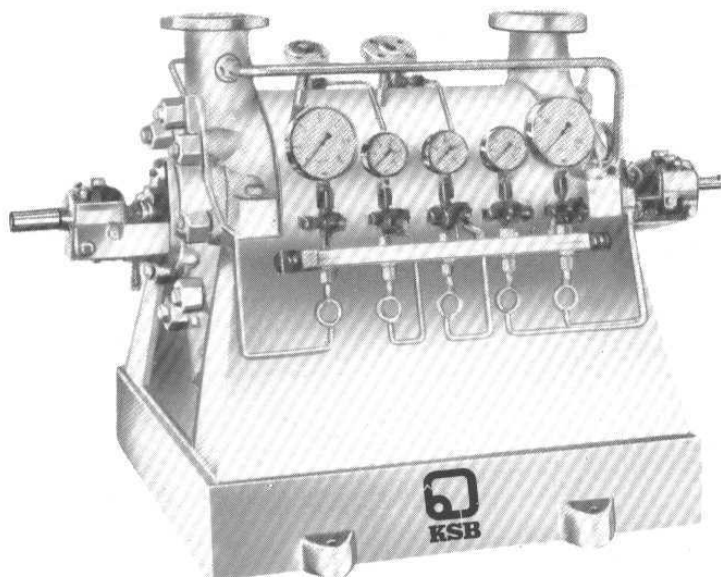

Work number (OP): _____

Type series: _____



These operating instructions contain fundamental information and precautionary notes. Please read the manual thoroughly prior to installation of unit, connection to the power supply and commissioning. It is imperative to comply with all other operating instructions referring to components of this unit.

This manual shall always be kept close to the unit's location of operation or directly on the pump set.

Contents

	Page		Page
1. Introduction	2	6 Accessories	8
2. Name plate	3	6.1 Minimum flow valve	8
3. Transport	3	6.2 Measuring instruments	9
4. Preservation and storage	4	6.3 Coupling	9
4.1. Preservation and storage additional procedures	4	7. Startup / comissioning, shutdown	10
5. Installation	4	7.1. Comissioning preliminary check	10
5.1. Pre-requisites	4	7.2. Startup	11
5.2. Preparations	4	7.3. Shutdown	11
5.3. Installation of the pump set	5	8. Maintenance	11
5.4. Pre-alignment of pump set	5	8.1. Operation supervision	11
5.5. Fastening the baseplate on the foundation	7	8.2. Lubrification	12
5.6. Pipings	7	9. Dismantling and reassembly	12
5.7. Vacuum balance line	8	9.1. Technical data and description	12
5.8. Auxiliary connections	8	9.2. Dismantling and reassembly	18
5.9. Balance liquid	8	9.3. Dismantling	18
5.10. Extracting piping	8	9.4. Assembly	22
5.11. Coupling guard	8	9.5. Spare parts	29
		10 Faults and causes	31
		Start-up check list	32

1. Introduction

KSB has supplied you with equipment that has been designed and manufactured with the most advanced technology. Due to its simple and tough construction it will not need much maintenance. With the aim of providing our clients with a satisfactory, trouble free operation, we recommend to install and care our equipment according to the instructions contained in this service manual.

This manual has been prepared to inform the end user about the construction and operation of our pumps, describing the adequate procedures for handling and maintenance. We recommend that this manual should be handled by the maintenance supervision.

This equipment should be used in the operational conditions for which it was selected as to: flow rate, total head, speed, voltage, frequency, and temperature of pumped liquid.

2. Nameplate



Figure 01 – Nameplate

For requests about the product, or when ordering spare parts, please indicate the type of pump and the Production Order n^o (serial n^o). This information can be obtained from the nameplate on the actual pump. If the nameplate is not available, the PO n^o is engraved in low relief on the suction flange, and on the discharge flange you may find the impeller diameter.

Attention: This manual contains very important instructions and recommendations. Its careful reading is an obligation before installation, electrical connections, first starting and maintenance.

3. Transport

The transport of motor-pump set or only pump should be made with ability and sound sense, according to safety standards. By the motor eyebolt should only lift it, never the motor-pump set.

In the case of motor-pump set the lifting cables must be disposed as shown on Fig. 02.

On pumps with a short baseplate or without a baseplate, attach the ropes as shown in Fig. 03.

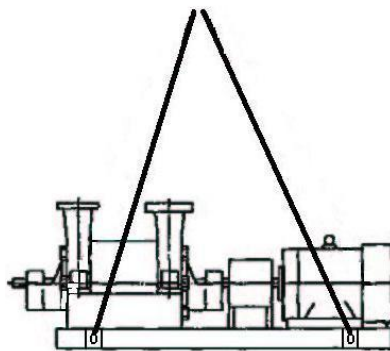

Figure 02

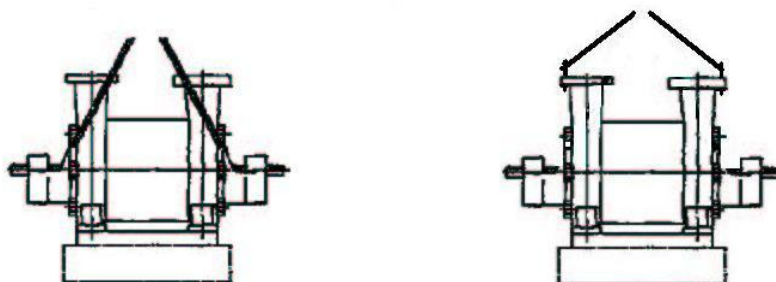

Figure 03

4. Preservation and storage

KSB standard storage and preservation procedures maintain the pump protected for a maximum period of 6 months in an indoor installation. It is client responsibility to keep these procedures after receiving the pump. The unit / pump should be stored in a dry room where the atmospheric humidity is as constant as possible.

After sale, if performance test is not executed, the areas that have contact with the pumped liquid and are not painted, for example, stuffing box, wear rings, flanges sealing area, etc., receive an application of RUSTILO DW 301, by brush.

When the pump contain packing and performance test is executed, after test, the pump is drained without disassemble. Afterwards the pump is fulfilled with RUSTILO DW 301, moving the rotor to optimize the application. Thereafter the RUSTILO is drained. The shaft exposed areas (end and region between gland cover and bearing bracket) receive an application of TECTYL 506, by brush.

Bearings assembled in pump support lubricated with oil receive MOBILARMA 524, by spray.

The pump must be protected against physical damage, humidity, dust and aggressive ambient, indoor.

4.1 Preservation and storage additional procedures

- Pumps stored for periods over 6 months must have the preservative process done each 12 month. The pumps must be disassembled, cleaned and the storage process must be done again.
- For pumps assembled with packing, they must be removed from the equipment before storage.
- Mechanical seals must be cleaned with dry air. Do not apply liquids or other preservative materials in order to not damage the secondary sealings (O´rings and flat gaskets).
- All the existent connections, like: plugs for liquids of external source, vent, drainage, etc., should be properly closed.
- The pump suction and discharge nozzles are properly closed with tape, in order to avoid strange bodies inside the pump.
- Before conservation liquids application, areas should be washed with gasoline or kerosene until they are completely cleaned.
- Assembled pumps waiting for start up or installation should have their rotor manually rotated each 15 days. In case of difficulty, use a box spanner, protecting the motor shaft surface at the point of application

The main characteristics of preservative liquids mentioned in this manual are:

Protecting liquid	Applied layer thickness (µm)	Drying time	Removal	Manufacturer
TECTYL 506	80 up to 100	½ up to 1 hour	Gasoline, benzol, diesel oil	BRASCOLA
RUSTILO DW 301	6 up to 10	1 up to 2 hours	Gasoline, benzol	CASTROL
MOBILARMA 524	≤ 6	Liquid	Not necessary	MOBIL OIL

Table 01

5. Installation

Pumps should be installed, leveled and aligned by qualified people. When this service is inappropriate executed, it can have as consequence, operational troubles, premature wear and irreparable damage.

5.1 Pre-requisites

- 5.1.1 The foundation has been prepared and the concrete has set.
- 5.1.2 The place of installation and the route thereto have been cleared and are suitable for transport of the pump set components.
- 5.1.3 Adequate means of transport and hoisting tackle, including personnel, are available until completion of the installation work.
- 5.1.4 Adequate alignment devices are available.
- 5.1.5 The installation may be performed without interruptions.
- 5.1.6 If welding work is performed on the pump set, we recommend to earth all baseplates of the pump set.

5.2 Preparations

- 5.2.1 In addition to this operating instruction, the technical documents on the other pump set components are also needed for the installation and alignment work. If these components are included in KSB´s scope of supply, the relevant documents are contained in product´s data book .
- 5.2.2 Check the foundation for compliance with the following criteria:
 - 5.2.2.1 The dimensions comply with those in the installation plan.
 - 5.2.2.2 The foundation as a whole and in particular the area surrounding the foundation holes is truly horizontal and even.
 - 5.2.2.3 If these criteria are not fulfilled, the requisite corrections must be reviewed with the site management and initiated.
- 5.2.3 Transport the pump set components to the place of installation.
- 5.2.4 If the pump set components are packaged, the packaging should not be removed until immediately before the installation work starts. When doing so, the pump set must not be damaged. The consignee of the components

supplied is responsible for disposal of the packaging.

Caution All openings of the mounted pump set components are closed and must not be opened until they are needed during installation.

- 5.2.5 Completely cover the pump set components to protect them for the full duration of the installation work on site against construction site dirt, spark discharge, grinding dust and other harmful ambient influences. Take special care to adequately protect instruments, electric cables and wiring ducts. Spare parts and parts which are not immediately needed must be stored.
- 5.2.6 Dismantle and store the coupling guards or coupling covers mounted on the pump set.

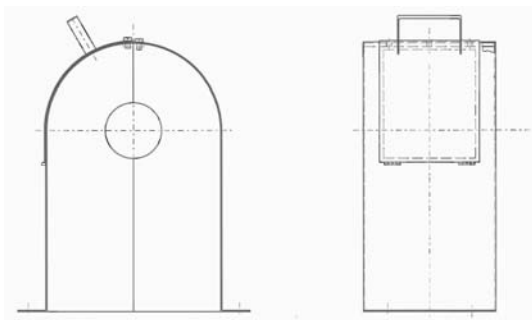

Figure 04

- 5.2.6.1 Disconnect the coupling guard.
- 5.2.6.2 Dismantle and store the spacer of the mounted connecting coupling as described in the manufacturer's documentation.

5.3 Installation of the pump set

- 5.3.1 Levelling the baseplate.
 - 5.3.1.1 Remove all the components (pump, motor, etc) from the baseplate placing it the installation local according to the installation plan.
 - 5.3.1.2 With the help of the spirit level, start the baseplate levelling repeatedly under 180°, from the support machined surface of the pump and driver. These surfaces must be leveled, transversal and longitudinal in the 0,2 mm / m. Levelling corrections should be done through the screws supplied in the baseplate. In order to help in the baseplate levelling, carbon steel wedge should be placed between the baseplate and the foundation, at the left and the right of the anchor bolt fix point. The levelling wedge height should be as sufficient as to permit a minimum height of the grouting of 25 mm

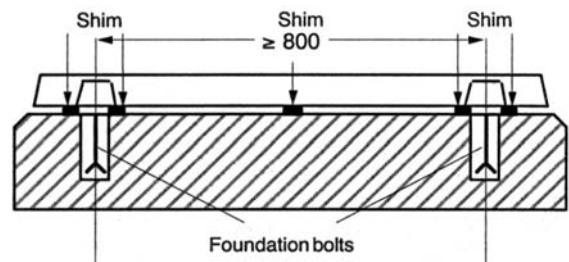

Figure 05

5.4 Pre-alignment of pump set



Secure the drive against unintentional starting.

- 5.4.1 Place the pump and driver over the metallic baseplate and start alignment of pump set.
- 5.4.2 In the case of electric motors with axial tolerance, their rotors must be placed in the magnetic centre as described in the manufacturer's documentation. This rotor position must not be altered during the full duration of alignment work.
- 5.4.3 Check the distance between the coupling hubs for compliance with the installation plan and adjust it, if required.
- 5.4.4 **Run-out check**
Check each coupling hub for run-out using a dial gauge, see figure Run-out check. The run-out must not exceed 0.03 mm; if it is exceeded, KSB must be informed.

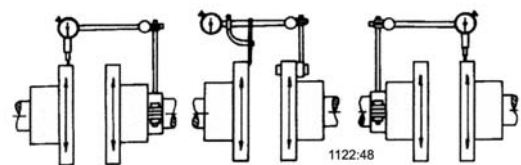

Figure 06 – Run-out check (example)

- 5.4.5 In the case of electric motor drive, the alignment starts with the pump. In the case of turbine drive, the alignment starts with it. Thereafter alignment of all the other components should be done.
- 5.4.6 Perform the alignment with dial gauges in accordance with the manufacturer's documentation. The figures 07 and 08 are examples of alignment with dial gauges:

Caution The coupling must not be turned by means of the alignment device!

Caution Both coupling hubs must be turned together in the same direction by 90° each in order to ensure that the measuring points are the same.

A = coupling hub used as a reference point for alignment.
B = coupling hub to be aligned.

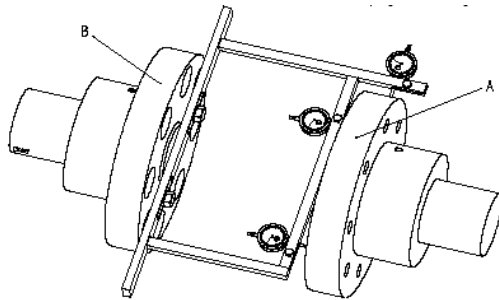

Figure 07 – Connecting coupling alignment with spacer (example)

A = coupling hub used as a reference point for alignment.
B = coupling hub to be aligned.

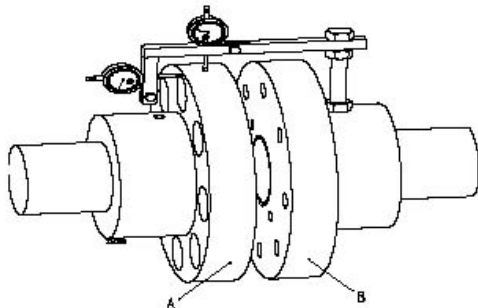

Figure 08 – Connecting coupling alignment without spacer (example)

5.4.7 As an alternative, the coupling may be aligned using a laser device.

Caution Only use laser devices where unintentional radiation is avoided and no injury to health is caused by the optical device for setting and observing. Injuries to health by reflection and effective, leakage or secondary radiation must be prevented by protective screens.

5.4.8 Permissible misalignment of the coupling hubs (KSB requirement):

5.4.8.1 The radial displacement Δkr must not exceed 0,03 mm, measured in planes displaced by 90°.

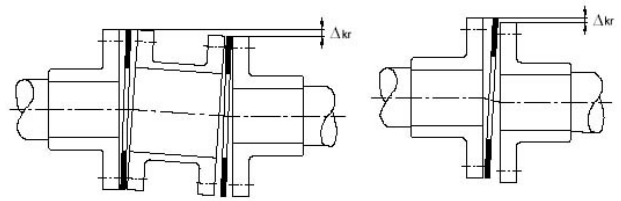

Figure 09 – Radial displacement (examples)

5.4.8.2 The angular misalignment Δka may be 0,03 mm in horizontal and vertical direction.

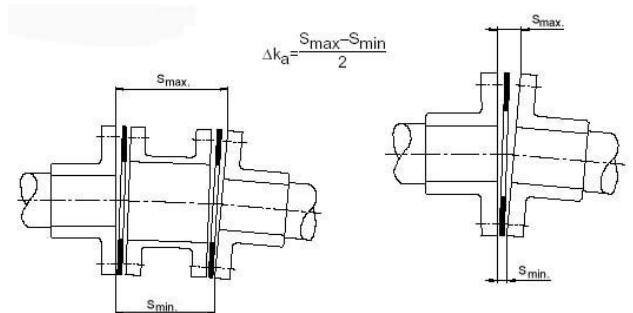

Figure 10 – Angular misalignment (examples)

5.4.9 Alignment corrections on the pump

5.4.9.1 In case corrections are necessary, should add shims to the driver feet by means of metal sheet of corresponding thickness. In the case of drive by turbine alignment should be executed considering that the turbine will be dislocated determining the value in the vertical position (thermal dilation), that means, the turbine should be positioned below the pump center line with the same value it will dislocate. We recommend re-check of alignment, by hot, after 30 min. of functioning.

5.4.9.2 Lateral correction of the pump:

5.4.9.2.1 Loosen the nuts of the studs used for fastening the feet.

5.4.9.2.2 For pump sizes HDA 100; 125 and 150 loosen the nuts of the relevant adjusting screws and perform the lateral correction by means of the adjusting screws (2) which stay at the casing guide (1) in the casing lower part. For pump sizes below from HDA 100, guide casing must be pinned by parallel pins after final alignment.

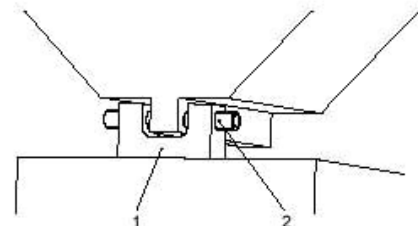

1 = guide casing
2 = adjusting screw

Figure 11 – Lateral correction (example)

5.4.9.3 Do not tighten the nuts of the adjusting screws firmly, because the connecting coupling alignment still must be repeated several times.

5.5 Fastening the baseplate on the foundation

5.5.1 Foundation bolts

Place the anchor bolts on the baseplate holes and screw the nuts at the ends, up to the anchor bolt screw project 10 mm over the nuts. Observe the position of anchor bolts in it's holes.

5.5.1.1 Fill all trench of the foundation block completely with non-shrinking concrete grout, minimum compressive strength class C 25/30, grain size < 5 mm according to the excerpt from DIN 1045. The flowability must be produced with the help of a fluxing agent. For more details please check item 5.5.2.2 below.

5.5.1.2 Baseplate grouting:

5.5.1.2.1 Prepare the final grouting for the baseplate up to the planned height as shown in the installation plan.

5.5.1.2.2 Make provisions for the grouting compound to bond with the foundation concrete.

5.5.1.2.3 Fill all fields of the baseplate completely with non-shrinking concrete grout, minimum compressive strength class C 25/30, grain size < 5 mm according to the excerpt from DIN 1045. The flow ability must be produced with the help of a fluxing agent. Complete grouting without major interruptions. For more details please check item 5.5.2.2 below.

5.5.1.3 When the grouting compound has set, check the nuts of the foundation bolts for tightness once again using a torque wrench, torque of 193 N.m.

5.5.1.4 Provide final alignment of pump set, according to the section 5.4, from item 5.4.4.

5.5.1.5 After final alignment the pump feet and the guide casing must be pinned to avoid lost the alignment of pump set.

5.5.2 Extract of standard DIN 1045-1

5.5.2.1 Admixtures for concrete

Admixtures are substances which are added to the concrete and which, by chemical or physical action, or both, change the concrete properties, e.g., its workability, hardening or setting. They provide negligible bulk.

5.5.2.2 Strength class

Exposure class	Minimum compressive	Cylinder compressive strength	Cube compressive strength
		N / mm ²	N / mm ²
XC4	C25/30	25	30

5.5.3 Addition agents

5.5.3.1 For concrete and "grouting" – also for placing any reinforcement in position – only admixtures as per item 5.5.2.1 and exhibiting valid test symbol, and only under the conditions stated in the test certificate.

5.5.3.2 Chlorides, chlorid or other substances, expediting the corrosion of steel, must not be added to reinforced concrete, as well as concrete and grouting coming into contact with reinforced concrete.

5.5.4 Minimum cement content

(According to DIN 1045-2)

Allowable for admixtures

Minimum compressive strength class	Minimum cement content in kg/m ³ of compacted concrete	Water cement value (WZ) for thickness up to 0,40 m
C 25 / 30	270	* W / Z ≤ 0,60

5.5.5 After complete hardening of the "grouting", repeat the alignment from item 5.4.4.

5.6 Pipings

Never use the pump as an anchorage point for the piping.

Suction lift lines should be run with a rising slope towards the pump, positive suction lines with a downwards slope towards the pump.

The pipes should be supported very near the pump and should be connected to the pump without transmitting any stresses and strains to it. The pump must not bear the weight of the piping.

The nominal bores of the pipes should be the same as or greater than those of the pump nozzles. We recommend installing non-return valves and shut-off valves, according to the type of installation.

Thermal expansion of the pipework should be accommodated by suitable means so as not to impose any extra load on the pump.

For permissible nozzle loadings see foundation plan sent together with product data book.

Before commissioning a new installation, thoroughly clean, flush and blow through all vessels, piping and connections. As welding beads, scale and other impurities frequently only become dislodged after a certain period of time, it is necessary to fit a strainer in the suction line, as close as possible to the suction nozzle, to stop entering the pump. The total cross-section of the holes in the strainer should be three times the cross-section of the piping to prevent excessive

pressure loss across the strainer caused by clogging. The pressure drop in the line must not exceed 3 m.

Note: The loss of maximum load in the suction line should not exceed 2 mca.

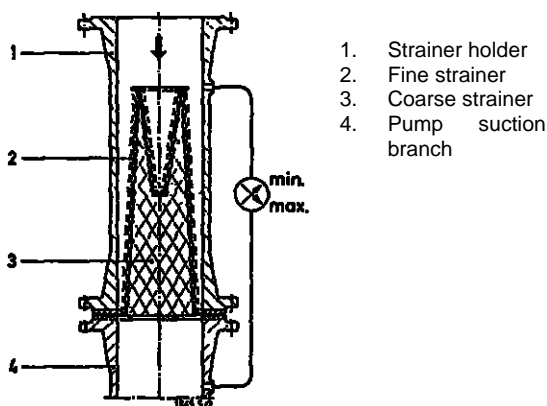
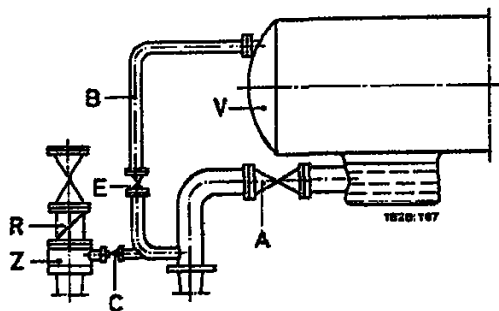

Figure 12

5.7 Vacuum balance line

If the pump has to pump liquid out of a vessel under vacuum, it is advisable to fit a vacuum balance line. This line should have a minimum N.B. of 25 mm and should be arranged to lead back into the vacuum vessel at a point above the highest permissible liquid level.

An additional line with shut-off valve from the pump discharge nozzle facilitates pump venting prior to startup (see Fig. 13).



- A Main shut-off valve – suction side
- B Vacuum balance line
- C Vacuum-tight shut-off valve
- E Vacuum-tight shut-off valve
- R Non-return valve – discharge side
- V Vacuum vessel
- Z Intermediate flange

Fig. 13 - Suction line and vacuum line

5.8 Auxiliary connections

The auxiliary connections (cooling, sealing, etc) necessary to the perfect functioning of the pump, should be checked and executed according to the set drawings, piping plan and other supplied documents.

5.9 Balance liquid

The balance liquid flow rates QE are given as mean values of various measurements. They relate to a pump speed of 2900 1/min, 50Hz and can be converted linearly for other speeds.

The return of the balance liquid to the suction branch or tank is dependent on the product temperature, the number of stages and the NPSH available.

With dropping de-aerator pressure the balance liquid must always be fed back to the suction tank. If a booster pump is used this liquid must be returned to the suction chamber.

The flow velocity in the balance line must not exceed 5 m/s.

When returning the balance liquid to the suction tank the balance liquid pressure must be at least 0,5 kgf/cm² higher than the suction pressure at the pump inlet; the build-up pressure must not exceed 2,5% of the pump discharge pressure. If, when liquid is fed back to the suction tank, the line is longer than 10 m increase the N.B. of the return line to the next size up.

(See sectional drawing attached on product data book for location of the connections 14A and E).

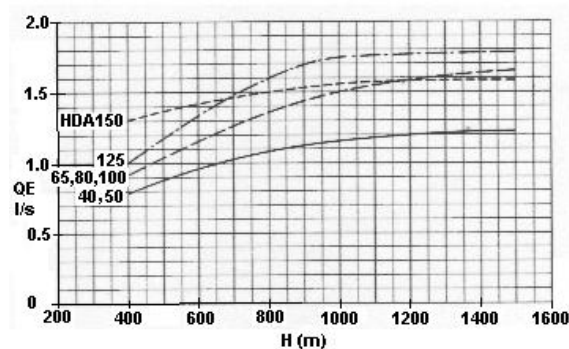

Figure 14 – Balance liquid flow rates

5.10 Extracting piping

If the pump has flow extraction flange in one or more stage casings, it should be assured that it or they are always opened during the operation in order to guarantee part of minimum necessary operation flow for the pump.

5.11 Coupling guard

Safety regulations stipulate that the pump must be fitted with a coupling guard. If the purchaser specifically states that he does not want us to supply a coupling guard, it must be provided by the operator.

6. Accessories

6.1 Minimum flow valve

When the pump work flow is reduced the necessary Power is not reduced in the same proportion, on the contrary, it is relatively high, inclusive with a zero flow. This absorbed power transform into heat inside the pump, that means the liquid is heated in it's interior. With

the purpose not to produce evaporation, the minimum flow must be re-circulated.

The minimum flow value of continuous operation is of 50% of BEP flow (point of better efficiency) and it is found in the pump data sheet.

Generally the minimum flow will be assured by an automatic valve (Fig. 15). If the minimum flow valve has been supplied, please consult respective operation instruction, which will be together with the supply documents.

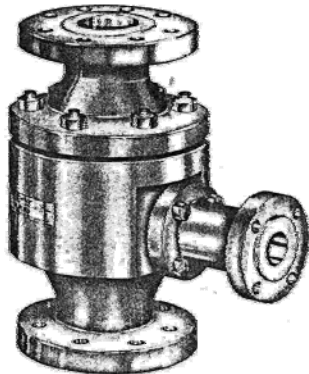

Figure 15 –Minimum flow valve

6.2 Measuring instruments

Our supply scope normally comprehend the following measuring instruments:

- Suction pressure manometer
- Discharge pressure manometer
- Balance liquid circuit manometer
- Minimum flow circuit manometer
- Intermediate extraction manometer (If applicable)
- Bearing temperature control manometer

6.3 Coupling

The gear couplings are recommended for high speed, fluctuant shafts and high pressure pumps. The models with gap disc are recommended for applications with motors with sliding bearings.

6.3.1 Assembly

6.3.1.1 Care

Carefully clean all the coupling surfaces, specially joint surfaces and biting surfaces.

Heat the hub in an oil bath or stove up to 135 °C.

Do not rest teeth gear at the recipient bottom or apply flame directly to the gear teeth.

Use recommended lubricant by the elastic sleeve manufacturer.

Fulfill the cover teeth with grease and bent the sealings softly with grease before assembly.

6.3.1.2 Coupling parts assembly

Place the teeth cover with Seal rings over the shafts before hubs assembly as shown on Fig. 16. Install the hubs in it's respective shaft the way the face of each hub

remain close to the shaft end. Position the equipment in approximately alignment, with approximately distance between the shafts.

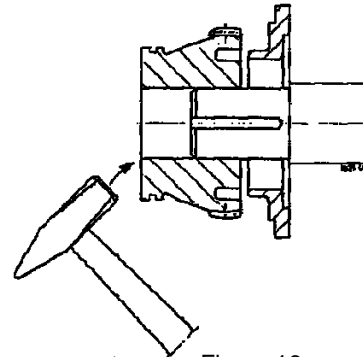

Figure 16

6.3.1.3 Clearance and angular alignment

Use a internal micrometer as shown on Fig. 17, measure the distance between the shafts at intervals of 90°. The difference between the minimum and maximum measure should not exceed the angular limit specified in table 1.

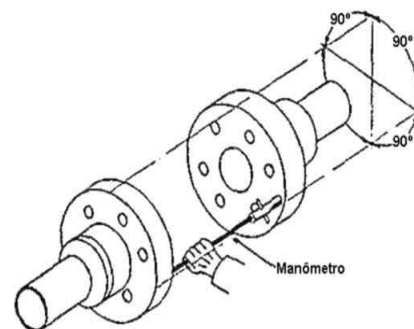

Figure 17

6.3.1.4 Parallel alignment

Align until a ruler seat in a square (or within the limits specified in table 02).

Over both hubs as shown on Fig. 18 and also at intervals of 90°. Check with lamina gauge. The interspace could not exceed the limit deviation specified in table 02. Strongly tight all the bolts and repeat steps 3 and 4. Re-align the coupling if necessary. Grease the hub teeth.

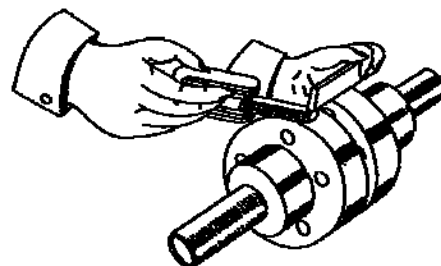

Figure 18

6.3.1.5 Assembly and lubrication

Check on table 02 the necessary grease quantity. Fulfill the teeth with grease, softly bent the sealings with grease and insert post. Screw cover and post in the rigid hub and apply torque in the bolts. Remove threaded plug of each cover and complete with grease both covers until overflow through the opened hole, place the threaded plugs.

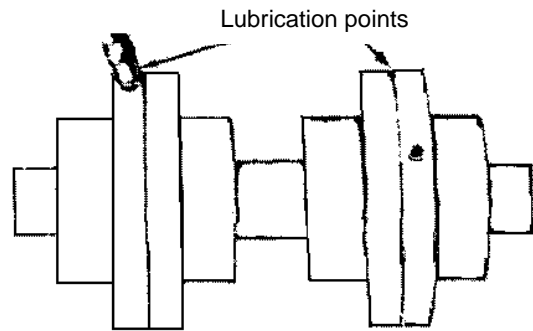

Figure 19

To determine the distance between shafts, measure all the fluctuant shaft and spacer length flange to flange.

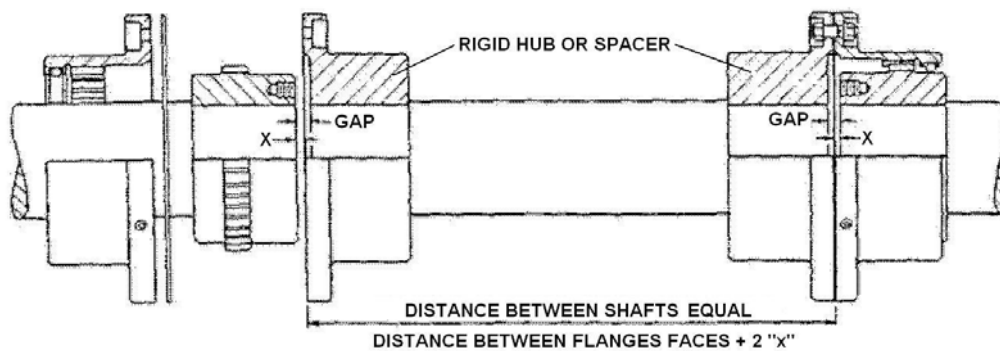

Figure 20

Size		10	15	20	25	30	35	40	45	50	55	60	70
Clearance – mm		4	4	4	5	5	6	8	9	9	9	9	13
Dimension x – mm		2	2	2	2	2	3	3	4	4	4	4	5
Alignment limits for functioning – mm.	Max. Parallel	0,13	0,13	0,25	0,25	0,30	0,30	0,30	0,30	0,30	0,30	0,30	0,30
	Max. Angular	0,13	0,13	0,25	0,25	0,40	0,40	0,30	0,50	0,50	0,80	0,80	0,80
Bolt tightness with torque, Kg x cm	G 31 and G 51	85	155	155	380	380	765	765	765	1350	1350
	G 32 and G 52	80	160	330	650	650	1170	1170	1170	1300	1300	1300	1960
Grease Weight Kg	Fig. 20: Coupling, each end	0,015	0,03	0,09	0,12	0,17	0,23	0,40	0,54	0,79	0,96	1,68	3,15
	Fig. 20: Spacer, in lenght Kg x m	0,015	0,015	0,015	0,03	0,03	0,06	0,09	0,09	0,09	0,09	0,09	0,09
	Fig. 20: Coupling without spacer	0,03	0,06	0,17	0,23	0,34	0,45	0,79	1,07	1,58	1,58	3,45	6,30
Extraction bolt size of gear hub – UNC (pol.)		5/16"-18	3/8"-16	1/2"-13	5/8"-11	3/4"-10	3/4"-10	3/4"-10	3/4"-10	7/8"-9	1"-8

Table 02 – Data of coupling installation

ATTENTION: Alignment limits of pump and drive are indicated on items 5.4.4 till 5.4.8.2.

7. Startup / comissioning, shutdown

7.1 Comissioning preliminary check

In order to avoid any failure before start up, we recommend analyze and check-list fulfillment of attachment I.

7.1.1 Lubrication

Check bearing and lubrication and apply the required lubricant type and quantities as stipulated. See item 9.1.3. for details of lubricant grade and fill.

7.1.2 Shaft seal

Check shaft sealing, see item 9.1.4.

7.1.3 Priming the pump and associated checks

Vent and prime the pump and suction line before startup. The shut-off valve in the suction line must be fully open. Fully open all auxiliary lines (flush, sealant, coolant etc.) and check the flow.

Open the shut-off valve in the vacuum balance line "E" (if fitted) and close vacuum-tight "C" (figure 13).

7.1.4 Checking the direction of rotation with the pump primed

The direction of rotation must match the arrow on the pump. Check this by switching the pump on and then off again immediately.

7.1.5 Commissioning

If commissioning takes place more than 5 months after installation, the following checks must be repeated.

1. Ensure that the couplings are in perfect alignment.
2. Check the main piping is connected stress-free / pretensioned as specified.
3. With toothed couplings it must be possible to shift the coupling housings slightly in the axial direction.
4. Remove the pump bearings, clean and replace (see section "Dismantling the pump").
5. Check shaft seal.
6. Check operation of the measuring and monitoring equipment.
7. If the driver is an electric motor, check the direction of rotation with the pump primed by switching the pump on and then off again immediately. The direction must match the arrow on the pump.
8. Follow startup instructions for turbine drive.

7.2 Startup

7.2.1 General

Open the shut-off valve in the minimum flow line. Only switch on the pump (motor) with the discharge valve closed. Slowly open the discharge valve to obtain the required duty point after the pump has reached full speed. Check the pressure loss in the suction line by differential pressure measurements; this should not exceed 2m.

7.2.2 Start-up with turbine

In the case the driver is a steam turbine certain recommendations must be observed.

- Turbines with fast startup
Turbines prepared for immediately startup, that means, they are heated through by-pass line from escape or other way and are ready to start operation.
When put in action they should increase it's rotation up to the pump nominal rotation, or at least, up to it's minimum rotation.
- Turbines with slow startup
Turbines that need to be pre-heated for startup, that means, don't have condition to maintain heated when in the stand-by position.

In this situation the pre-heat or 1^a turbine startup should be made not coupled to the pump and can this way increasing gradually it's rotation until it reaches the desired temperature.

Never couple the pump and maintain the turbine at the slow turn in order to maintain the turbine heated and ready for startup.

The slow turn is an operation condition of the turbine in very low rotation and below the minimum indicated rotation for the pump and has a unfavorable effect to the disc system and counter disc of pump axial compensation.

Therefore, in this situation it is recommended to the turbine manufacturer to dispose a way to maintain the turbine heated, which do not rotate the pump in low rotations.

With the turbine heated and ready for startup it will increase the rotation up to the pump nominal rotation, or at least, up to it's minimum rotation.

7.2.3 Startup with electrical motor

If the driver is an electric motor pay attention to the startup type, in order to avoid that the pump operates in a rotation below the minimum indicated.

The best condition is to startup the electrical motor until the rotation is fast completed.

If frequency inverter is used, should observe the minimum indicated rotation for the pump to be directly reached.

In the case of startup with soft-starter, compensated key or star-delta, an adjust should be made in order to reach the nominal rotation in no less than 5 seconds.

7.3 Shutdown

Close the shut-off valve (if applicable, close also intermediate extraction valve).

It is essential that a non-return valve is fitted in the discharge line and that sufficient back pressure is available.

Switch off the driver, checking that it runs down smoothly to a standstill.

In case the pump shutdown takes a long time, close the valve in the suction line.

In pumps which handle liquid from a vessel under vacuum, the shaft seal must be fed with sealant even when the pump is at standstill.

If there is the danger of frost and / or in the event of prolonged periods of standstill, drain the cooling chamber or protect the pump from freezing.

In the case of driver with frequency inverter or soft starter the shutdown should be immediate; the desacceleration ramps are extremely damage to pump balance system.

8. Maintenance

8.1 Operation supervision

The pump must run smoothly and evenly at all times.

The pump should not work dry.

Prolonged operation against a closed discharge valve (> 10 min.) must be avoided, even if the minimum flow system is in operation (part load cavitation, wear to the minimum flow valve).

The bearing temperature may exceed ambient temperature by 50°C, but not go above 80°C.

Check the rotor position using the indicator (see item 9.1.1).

The shut-off valves in the supply lines must remain open during operation.

See item 9.1.4 for details of shaft seal monitoring.

Check the suction pressure and temperature and the pump the pump discharge pressure and temperature.

Check the cooling-liquid flow rate and temperature (if applicable). The maximum permissible difference between inlet and outlet temperature is 10°C. We recommend recording this information in a logbook.

Standby pumps should be started up then immediately shut down once a week to keep them operational. Also check the integrity of the auxiliary connections. The flexible coupling elements should be regularly checked and replaced as soon as they show signs of wear.

Measuring equipment

The suction and discharge nozzles of each pump should be equipped with a pressure gauge / thermometer having a suitable range for the pressure / temperature involved, plus a pressure gauge cock or valve. Where the suction conditions dictate, the suction nozzle should be equipped with a mano-vacuumeter (additional measuring equipment is available on request).

8.2 Lubrication

Check the quality and quantity of the bearing and lubrication according to item 9.1.3.

9. Dismantling and reassembly

(See Sectional drawings on data book for part n°).

9.1 Technical data and description

9.1.1 Rotor position indicator

The indicator sleeve (623.1) which is screwed into the bearing end cover (361) has two markings at right angles to the pump axis. The non-drive end marking indicates the position of the pump rotor when operating with a new balance device (601 and 602). The pump side marking (2,0 mm away from the non-drive end marking) indicates the permissible amount of balance device wear.

If the end of the pin (624) in line with the pump side marking, this means the balance device (601 and 602) is so worn that it must be replaced (see Figs. 21 and 22).

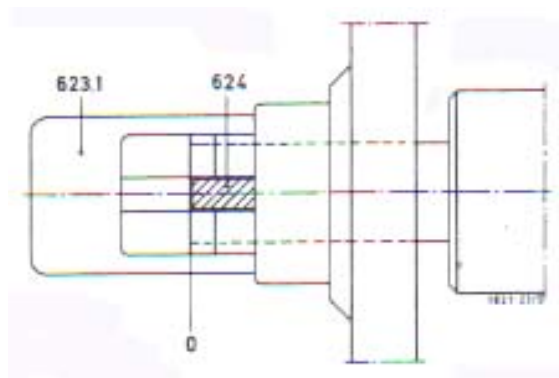

Figure 21 – Rotor position, pump operation normally

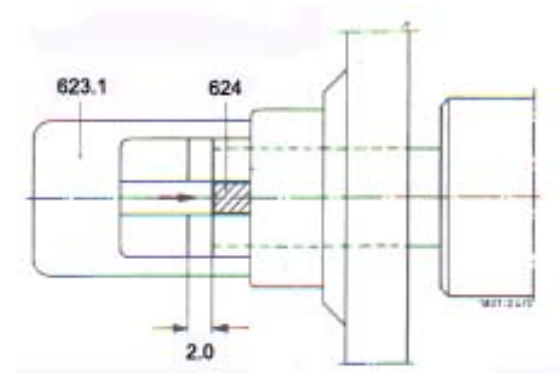
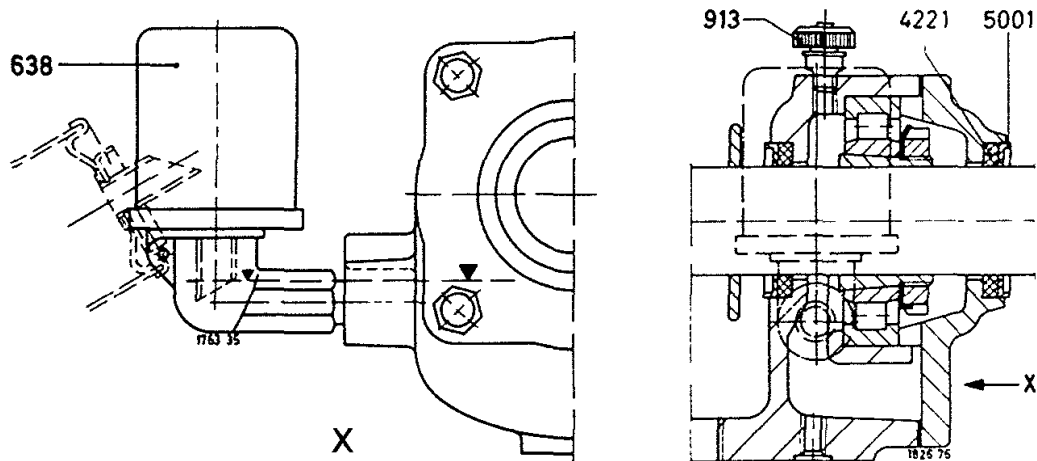

Figure 22 – Rotor position, shut pump down

9.1.2 Bearings

Figure 23A – Bearing arrangement with rolling bearings



Part n°	Denomination
422.1	Felt ring
500.1	Ring
631	Constant level oiler
913	Vent plug

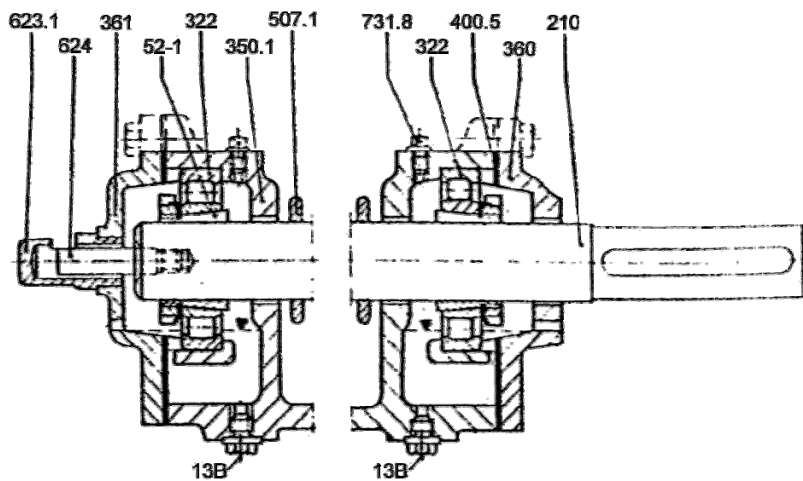

Part n°	Denomination
210	Shaft
322	Rolling radial bearing
350.1	Bearing housing
360	Bearing end cover
361	Bearing non-end cover
400.5	Flat gasket
507.1	Thrower
52-1	Conic bush
623.1	Position indicator
624	Control pin
731.8	Threaded plug
13 B	Oil drain

Figure 23B – Bearing arrangement with sliding bearings

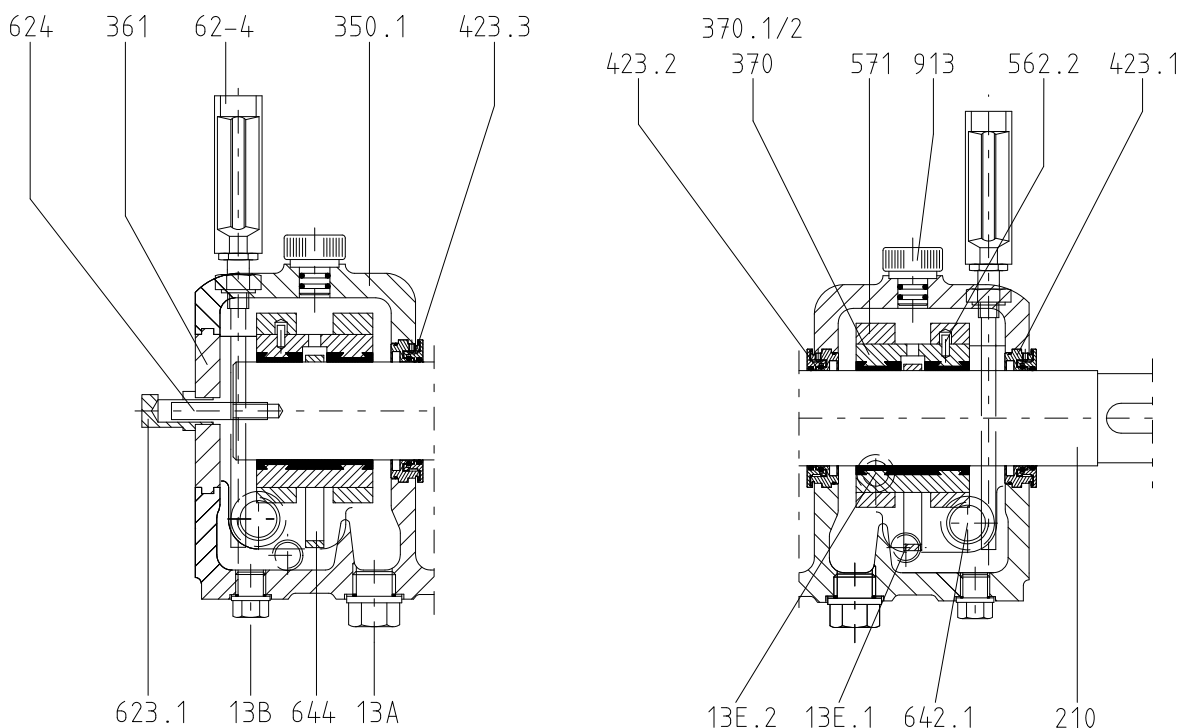

Part n°	Denomination
210	Shaft
324	Control pin
350.1	Bearing housing
361	Bearing end cover
370	Bearing shell
370.1/2	Bearing shell
423.1/.2/.3	Bearing isolator
507.1	Thrower
562.2/.3	Pin
571	Clamp
623.1	Rotor indicator
624	Actuating pin
62-4	Termometer
642.1	Oil level sight glass
644	Lubrication ring
913	Vent plug
4 M	Connection for temperature control
7 A	Cooling outlet
7 B	Cooling inlet
8 B	Stuffing box drain
13 A	Oil drain
13 B	Oil drain
13 E.1/E.2	Oil inlet

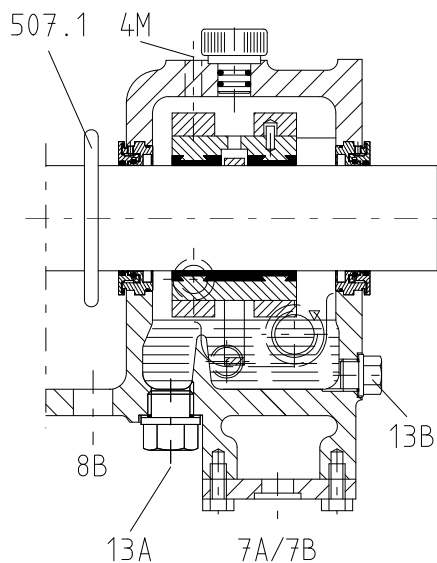

Figure 23 C – Cooled sliding bearing housing

The shaft (210) runs in two plain bearings (370). The shells on these bearings are attached to the bearing housing by means of clamps (571).

Use connections 13A and 13E.1, for forced oil lubrication from the external unit.

The oil temperature in the bearing housing may rise to 50° C above ambient temperature but should not exceed 80° C.

The housings (350.1) must be cooled if the product temperature exceeds 150°C and the ambient temperature simultaneously exceeds 45°C, using connections 7E and 7A according to figure 23C.

At product temperatures over 200° C the bearings must always be cooled.

9.1.3 Lubrication

9.1.3.1 Oil lubrication

a) Execution with ball bearings

The bearings are submerged in oil bath and the correct level is guaranteed by the constant level oiler (638). (see figure 23A).

b) Lubrication with oil bath and lubrication oil ring (execution with sliding bearings) (see fig. 23B and 23C).

On bearings lubricated by lubrication ring, the lower halves of the bearing housings (350.1) are filled with enough oil to guarantee that the lubrication rings (644) dip into the oil, thereby ensuring the bearings are lubricated after the first few turns of the shaft. An oil level sight glass (642) is provided to allow inspection on the oil fill.

Check table 03 to obtain oil volume per bearing.

c) Lubrication with forced oil lubrication (execution with sliding bearings)

The oil feeding to the bearings during the operation can be deriving from separated lubrication unit.

The oil pump of lubrication unit, or an auxiliary oil pump lubrication, should lubricate the main pump before startup and soon lubrication even after the main pump is turned off during the rotation period by inertia up to shutdown.

The description of separated lubrication unit, if applicable, is available in specific documentation supplied with the equipment data-book.

Consult table 03 to obtain oil consumption per bearing.

9.1.3.2 Oil quality

Designation	Lubricating oil CLP 46 DIN 51 517 Or HD 20W / 20 SAE
Symbol to DIN 51 502	□
Kinematic viscosity at 40 °C	46 + / - 4 mm ² /s
Flash point (to Cleveland)	+ 175 °C
Solidification point (pour point)	- 15 °C
Application temperature ¹⁾	Higher than permissible bearing temperature

¹⁾ For ambient temperatures below -10° C another suitable lubricating oil type must be used.

9.1.3.3 Oil Quantity

Constructive size	Bearings drive end and non-drive end		Oil volume per bearing (l)	Plain bearing			Design with lift-off device ³⁾			
				Inner diameter x length (mm)	Oil fill per bearing (l) ¹⁾	Oil consumption (l/min) ²⁾	With ball bearing			Additional oil consumption for segmental thrust bearing with forced oil lubrication (l/min) (See figs. 42 and 43)
							Bearing design (See fig.41A) ⁴⁾	Bearing design (See fig.41B) DIN 628	Oil fill (l)	
40/50	NU208K H208	DIN5412 DIN5415	0,2	35 x 50	0,40	2	7305-BUA	Angular contact ball bearing 3309-C3	0,02	6
65	NU210K H210	DIN5412 DIN5415	0,2	45 x 60	0,40	3	7306-BUA	Angular contact ball bearing 3310 BTNG C3	0,05	6
80	NU210K H210	DIN5412 DIN5415	0,2	45 x 60	0,40	3	7307-BUA			6
100	NU211K H211	DIN5412 DIN5415	0,3	50 x 60	0,50	4	-			8
125	-	-	-	50 x 70	0,70	6	-			10
150	-	-	-	75 x 85	1,30	8	-			10

Table 03 : bearing sizes and volume / oil consumption

Notes:

¹⁾ For lubrication with oil bath and lubrication ring

²⁾ For lubrication with forced oil lubrication

³⁾ If fitted, see sectional drawing on product data book.

⁴⁾ Applicable for pumps with ball bearing

9.1.3.4 Lubrication schedules and oil change

For execution with ball bearing it is recommended to change the oil after about 300 hours of operation and then after every further 8000 hours or each year.

For lubrication in oil bath with lubrication ring the first oil change should be made with approximately 300 hours of operation and then after every further 3000 hours operation.

For lubrication with forced oil lubrication the quantity and quality of oil in the reservoir of lubrication unit should be controlled each month. Change each 8000 hours operation.

9.1.3.5 Oil piping with forced oil lubrication

The oil feeding piping should be connected to the inlet and outlet connections from the pump bearings at the plant, during installation and following supply drawings. The return piping should be installed with inclination of approximately 2 degrees in direction of the reservoir.

ATTENTION:

The piping connection should be executed without stress.

a) Cleaning oil pipings

Unscrew all the connections points and close one side of oil piping.

Fulfill with caution pipings with inhibited chloridric acid. (Attention! The acid is heated and can sprinkle or form scum).

Preparation of inhibited chloridric acid

To the technical chloridric acid of 30-37% found in the market should add 13 grams of Brindi resin per Kg diluting the mixture in 6 additional water volume (for example: for 50 Kg of chloridric acid must add 650 grams of Brindi resin and is diluted with 300 liters water). Other inhibitor can be used, considering the quantities of composition dependent of inhibitor class.

The deburring process takes approximately 4 hours at 20°C.

Thereafter remove the acid and wash the pipings with cold water. The rest of acid is neutralized with a sodium solution at 0,5% (500 grams sodium / 100 liter water).

After 1 up to 2 hours reaction, remove the sodium solution and wash again with water. Immediately after that, blow with hot air, dry and line with oil to be used in service.

ATTENTION:

When working with chloridric acid it is imperative to use protective masks and protective sleeves and in case of concentrated acid it is necessary to use respiratory mask.

Carefully mix the chloridric acid in the water, no contrary.

b) Oil circuit wash

Before first startup, after repair works or after long standstill, provide with oil pump oil piping wash during many hours, cleaning the circuit filters.

This washing must be done with bearing shells (370) disassembled. After finish washing, control the oil in the reservoir regarding cleanness, and if necessary clean or change it.

Carefully clean the bearing casings with wash oil after finishing to wash the circuit and before mounting the bearing shells.

The oil must be washed immediately before comissioning.

9.1.4 Shaft sealing

Packed glands are used to Seal the shaft outlets. Subsequent conversion to a different type of seal is possible. In such cases consult the pump manufacturer for details of the components required and necessary machining work.

9.1.4.1 Packed glands

HW (hot water) type packed glands need not be cooled where product temperature is less than 105 °C.

With product temperatures of 106 °C up to 150 °C cooling is necessary (connections 7E.1 / 7A.1); where the product temperature exceeds 150°C the gland cover must also be cooled (connections 7E.2 / 7A.2). See Fig. 25 and 26.

Figure 24 shows the necessary cooling water flow rate. In this monogram the heating-up of the coolant was assumed to be $\Delta t = 10$ °C. If there is any deviation from the assumed temperature differential Δt the coolant flow rate changes according to the formula:

$$10 \cdot Q \text{ -----} = \text{effective coolant flow rate} \\ \Delta t$$

The temperature of the coolant at the cooling point outlet must not exceed 50 °C.

The nomogram values include approx. 10% for gland cover cooling.

For bearing cooling add 10%.

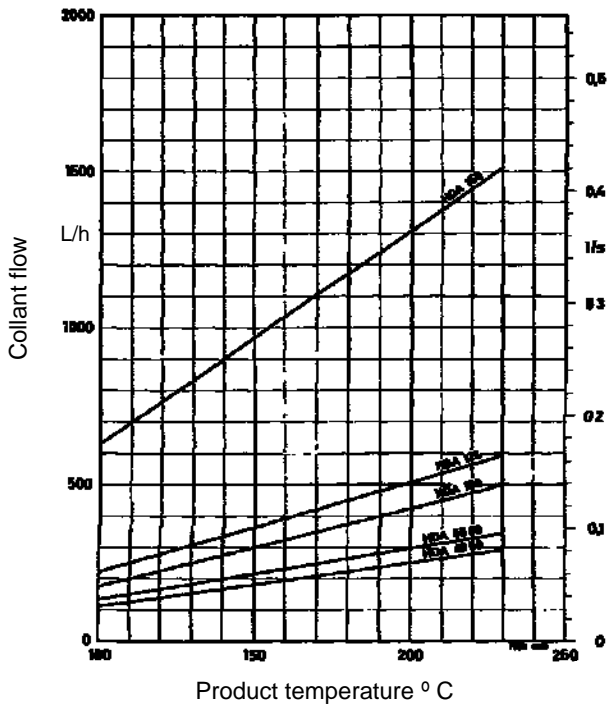

Fig. 24 - Cooling liquid requirement

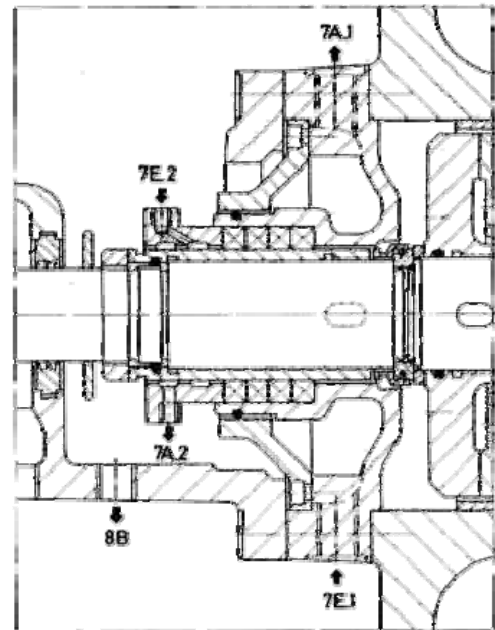

Fig. 26 - Packed gland type HW with cooled gland cover

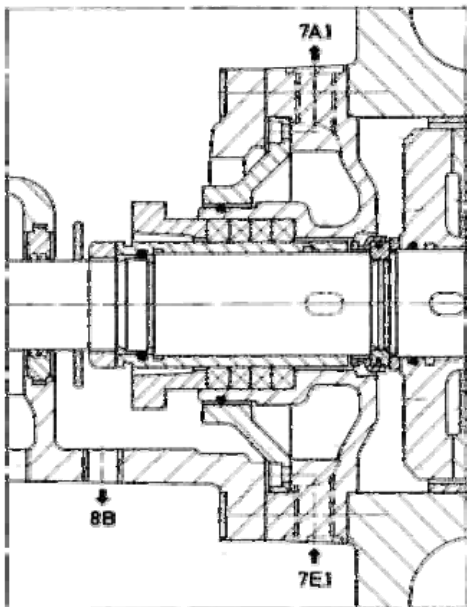

Fig. 25 – Packed gland type HW

9.1.4.2 Packing the stuffing box

Ensure that the packing material selected is compatible with the product. Always use new packing material which has preferably been stored for some time.

If the suction pressure exceeds 15 bar, we recommend die-forming the individual packing rings before insertion. (We can supply this press on request.) The pressing pressure should be approx. 10 bar.

Before inserting the packing, thoroughly clean the box and the shaft protecting sleeve and coat them with molybdenum disulphide or another approved lubricant. Insert the packing rings one at a time, pushing them home with the gland cover. Each ring should have its joint offset by 90° to the preceding one (See Fig. 27). Make sure there is a large enough gap at the top of the box to accommodate the gland cover. Lightly compress the rings using the gland nuts. Loosen the nuts and re-tighten them to finger pressure; using a feeler gauge, check that the gland cover seats correctly when under suction pressure.

ATTENTION:

All stuffing boxes must drip during operation.

Leakage rate = approx. 2 to 3 l/h.

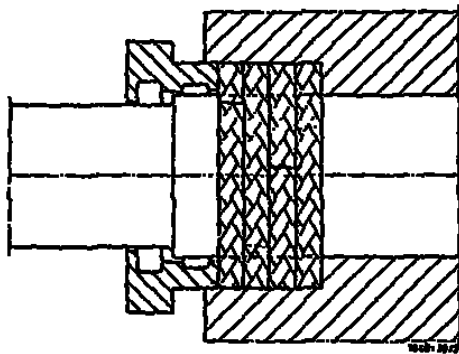

Fig. 27 - Gland packing

Pump sizes	Stuffing box sizes (mm)	Nº of rings	Packing cord per box (mm)
40 e 50	Ø 45/Ø 65 x 45	4	10 x 10 x 850
65 e 80	Ø 66/Ø 90 x 50	4	12 x 12 x 1000
100	Ø 70/Ø 95 x 50	4	12 x 12 x 1100
125	Ø 80/Ø 105 x 50	4	12 x 12 x 1300
150	Ø 101/Ø 125 x 53	4	12 x 12 x 1450

Table 04 - Measures for stuffing box and packing cord

9.2 Dismantling and reassembly

ATTENTION:

Before dismantling, make sure the pump is disconnected from the mains and cannot be switched on accidentally. The suction and discharge shut-off valves must be closed.

The pump casing must have cooled down to ambient temperature.

The pump casing must be empty and not under pressure.

Drain off the oil, remove the coupling guard. Separate the half couplings, removing the spacer, if fitted (see 6.3. "Coupling").

Remove the gland packing.

Check pump alignment at the coupling and note the reading (see section 5.4.4 till 5.4.8.2).

Disconnect the supply lines, as far as necessary. Always refer to the relevant sectional drawing during dismantling and assembly.

9.3 Dismantling

9.3.1 Rolling bearings execution

1. Remove coupling hub using suitable device (fig.28).
2. Remove drive side bearing cover (360) and non-drive side bearing end cover (361) including rotor position indicator (623.1).
3. Bend up lock washer between ring nut of clamping sleeve and radial roller bearing (322).
4. Screw ring nut backwards several turns.
5. Gently tap front face of ring nut to loosen clamping sleeve (531) on the shaft (210).

6. Withdraw clamping sleeve and bearing inner race from the shaft.
7. Extract bearing outer race from the bearing housing (350.1).
8. Undo and remove the nuts (920.2) of the studs (902.1) in the discharge casing (107) to allow access to the bearing housing and stuffing box housing.
9. Remove bearing housing (350.1).
10. Pull thrower (507.1) off the shaft (210).

9.3.2 Sliding bearings execution

9.3.2.1 Non-drive end bearing

1. Unscrew rotor indicator (623.1) and pin (624) regarding the position of rotor, if applicable. Execution with lift-off device and gear pump coupled to the shaft, this indicator and pin do not exist.
2. If applicable, remove the gear pump (632) and joint part (145) from the pump shaft loosening nuts (920.9).
3. Remove the lift-off device (antifriction bearings) loosening the studs (902.4) from bearing casing (350.2), when this accessory is included with the pump.
4. Loosen and remove the nuts on the fixing bolts of the top half bearing housing (350.1).
5. Remove the top halves of the bearing housing (350.1).
6. Loosen and remove the bearing clamp (733).
7. Remove the bearing end cover (361), if applicable.
8. Remove the top bearing shell (370), lubrication rings (644) and maintain the bearing isolator (423) on the shaft.
9. Check the rotor lift as per 9.4.8 "Rotor lift".
10. Remove bottom bearing shells (370).
11. Loosen the nuts (920.2) and studs (902.1), take out the tapered pins (560.2) and remove the bottom halves bearing housings (350.1).
12. Maintain the throwers (507.1) on the shaft.

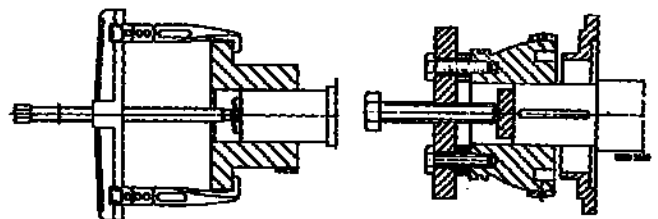

Figure 28 – Extraction of coupling hub

9.3.2.2 Drive end bearing

1. Proceed as per above items 4, 5, 6, 7, 8, 9, 10, 11 and 12.
2. Remove half of coupling hub using suitable device (fig. 28).

9.3.2.3 Shaft seal

1. Remove the gland cover (452.1/2) or gland if the sealing is provided by mechanical seals.
2. Pull back and take off the stuffing box housing (451) with the cooling cover (165).

Size 40 and 50

3. Undo the shaft protecting sleeve (524.1/2 and withdraw it from the shaft (210). Remember threads can be left-hand or right-hand

Size 65 and 150

4. Remove circlip (932.3) and pull the shaft protecting sleeve (524.1) off the shaft.

Size 65 under 125

5. Remove the suction-side key and pull the spacer sleeve (525.1) off the shaft.

9.3.2.4 Balance device

Pump sizes 40 and 50

1. Remove the balance disc (601), using the extractor.

Pump sizes 65 a 150

2. Remove collar (505.1) and remove split ring (501).
3. Pull off spacer ring (504.1).
4. Remove the balance disc (601) using the extractor.
5. If necessary, loosen retaining bolts of the balance counter disc (602) and withdraw this from the discharge casing (107) using the extractor, and pull spacer (525.2) off the shaft.

ATTENTION:

If you do not intend to dismantle the hydraulic parts of the pump, measure the approximate total radial play. Attach a dial indicator to a fixed support (e.g. flange or discharge nozzle) and place its tip against the seat of the balance disc (Fig. 29). Carefully raise the shaft to its upper dead centre, ensuring that there is no additional sagging of the shaft as this could give an incorrect measurement. The clearance measured here should not exceed 0,8 mm – if it does the pump must be dismantled and overhauled. The rotor clearances can only be measured completely accurately when the pump is dismantled.

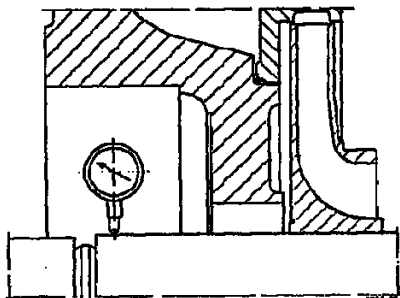

Figure 29 – Measuring the rotor clearance

9.3.2.5 Pump casing

1. Loosen the nuts (920.1) on the discharge-side tiebolts (905), cross-wise until they are only slightly pre-tensioned.
2. Loosen anchor bolts on pump feet / pedestals and lift the pump off the baseplate onto chocks. If the pump suction and discharge nozzles both face the same way the pump can also be set down on its nozzles for dismantling.

ATTENTION:

Take care not to damage the contact faces of the pump nozzles. Do not sling ropes under the pump shaft.

3. Remove cladding (680).
4. Unscrew nuts (920.1) on the discharge end of the pump and withdraw the tiebolts (905).
5. Chock up the stage casings (108) with blocks of wood or a stand so that the next components are accessible.
6. Press discharge casing (107) together with diffuser (171.2) from the stage casing (108). Do not damage seal faces.

ATTENTION:

Before dismantling, match-mark the stage casings (108) so they can be reassembled in the same order and position (see fig. 30).

7. Pull spacer sleeve (525.2) off the shaft.
8. Pull last stage impeller (230) off the shaft.
9. Remove the stage casings (108) together with the diffusers (171.1), stage sleeves (521) and impellers (230/231) off the following stages. The impellers (230 / 231) and stage sleeves (521) are secured against twisting by a common key on the shaft (210) and are stamped with matching numbers.
10. After the last stage casing (108), has been dismantled, draw the shaft (210) with first stage impeller (230 / 231) out of the suction casing (106) then pull the impeller (230 / 231) off the shaft (210).
11. Stack the stage casings (108) carefully so that the seal faces cannot be damaged (see fig 30).



Figure 30 – Stacking the stage casings

9.3.3 Examination of pump components

9.3.3.1 Shaft (210)

Check the running between centres on a lathe. Max. permissible shaft whip: 0,03mm. The shaft should never be straightened either warm or cold. If the maximum permissible shaft whip is exceeded, fit a new shaft.

ATTENTION:

Make sure the shaft is accurately centred on the lathe as otherwise the readings will be inaccurate.

9.3.3.2 Suction (106), discharge (107), and stage casings (108), impellers (230/231), spacer sleeves (525.1/2), stage sleeves (521).

Check all seal faces are in perfect condition. Check the plane parallelism of the sealing faces at four points with a micrometer. The deviation should not exceed 0,005 mm. Touch up any damaged surfaces, preferably on a lathe. The surface roughness should not exceed $Ra = 0,8 \mu m$ (superfinish turning). If damaged faces cannot be touched up on a lathe they may be reground.

If the pump casing has been adapted to match the shaft deflection, they mating faces on **two** adjacent stage casings will have been machined in such a way that the top gap between them is narrower than the gap at the bottom by a given amount. The stage casings are marked with the word "OBEN = TOP" at the top end of the periphery and with the reference number of the casing concerned. If the mating faces are touched up, the difference in size between top and bottom **must** be maintained.

The grinding equipment consists of a grinding disc and centering mandrel.

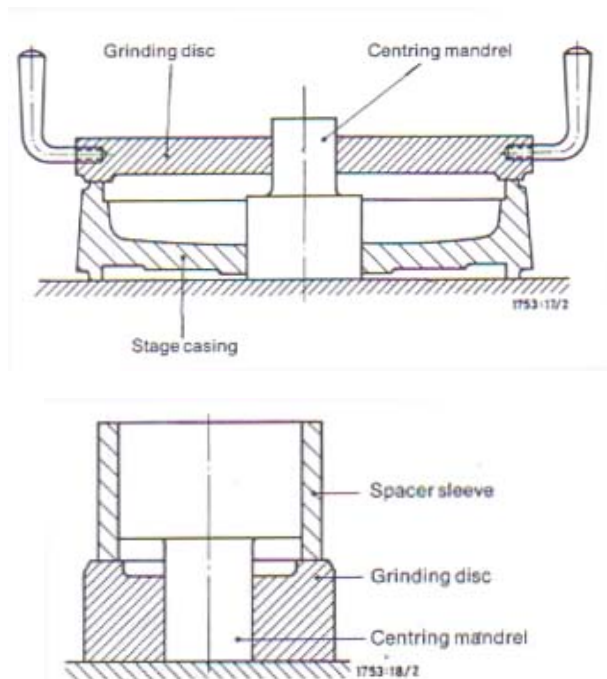

Figure 31 – Grinding the sealing faces

Never regrind a sealing face by using its mating face on the next stage casing as a grinding block, as this would open out the centering spigot.

The impellers (230 / 231), stage casings (108) and diffusers (171.1/2) are equipped with renewable wearing parts – impellers wear rings (503), casing wear rings (502), and stage bushes (541). Examine the wearing parts for signs of wear and check the rotor clearances as per table 05.

The wearing parts must only be remachined in situ within the max. permissible clearance limits. The increase in clearance caused by machining must also be adjusted at all the wear points in the pumps. If the rotor clearances exceed the max. values given in table 05 new wear parts must be fitted to re-establish "as-new" clearances.

Example:

Renewing the casing wear rings (502).

1. Push the casing wear rings out of their seats taking care not to damage the seats (see Fig. 32).
2. Press the new oversized wear rings into the bore (cooling the rings makes this easier).
3. Smooth down all impellers (230, 231) in the region of the fitted impeller wear rings (503) to a common diameter, basing this on the most heavily scored impeller wear ring. Individual deep grooves can be left untouched.
4. Calculate the average actual diameter of all smoothed down impeller wear rings. Adding this to the "as new" clearance as per table 05 gives to bore diameter for the casing wear rings, tolerance 0,04 mm.
5. Align the stage casing (108) and suction casing (106) with fitted casing wear ring to the outer fit and machine the wear ring **in one machine tool setting**.

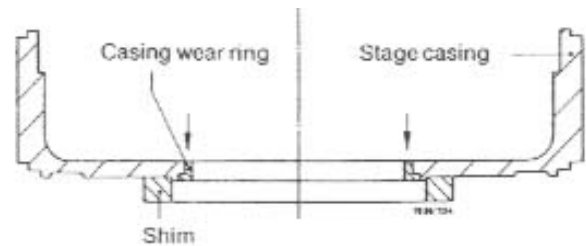

Figure 32

9.3.3.3 Ball bearings (322)

The bearings must be replaced by new ones if there are any sign of discolor and / or rust or damage. Use gasoline for cleaning of bearings that might be still used. After cleaning, these bearings must be immediately sprinkled with lubricant oil or greased.

9.3.3.4 Plain bearings (370)

Check the contact picture of the bore and eliminate any slight indentations using a scraper.

Check the fits of the plain bearings (370) with the bearing housing (350).

When fitted with the bearing clamp (571) tightened, it must be impossible to move the bearing shell in its seat. If the fit is too loose, uniformly remachine both faces of the bearing clamp (571) until the bearing shell will sit firmly in its seat without moving. When fitting new bearing shells always adjust the seat as described above.

9.3.3.5 Shaft seal

Shaft protective sleeves (524.1/2) should only be re-ground very lightly. Damaged sleeves should be removed and new ones fitted.

Only use new packing material.

If the protective sleeves and components of mechanical seals are damaged, these must be replaced by new ones. For marks relatively light in the contact surface, the stationary and rotative seats can be sent to the mechanical seal supplier for polishing.

ATTENTION:

Never admit that o-rings of etileno propileno have contact with oil or grease.

9.3.3.6 Balance device

Check the balance disc (601) balance counter disc (602), and spacer sleeve (525.2), for damage.

If the balance disc (601) touches the balance counter disc (602) remachine the faces on a lathe with arbours, this ensures the contact faces are then sufficiently true in relation to the bores. (Max. remachining 2 h = 2 mm, see fig. 33). Individual grooves can be allowed to remain.

Remachining the balance device:

If remachining causes 2 h to be exceeded you must fit a new balance device (601/602).

The total amount trimmed off the disc (601) and counter disc (602) must also be trimmed off the spacer sleeve (525), to maintain the previous rotor position in relation to the pump casing. Perfect plane parallelism of the spacer sleeve faces is essential.

The bottom of the remachined balance disc (601) should not press against the key. Carry out a check using bluing ink as per item 9.3.3.6.1.

When eliminating fouling in the radial gap between the counter disc (602) and spacer sleeve (525.2) by machining, apply the clearance specified in the table 05.

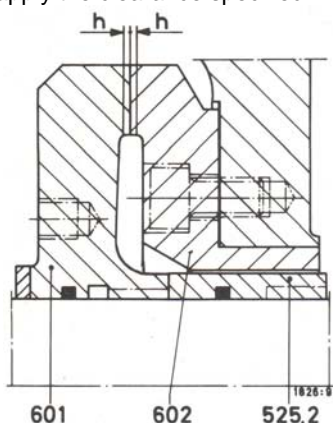

Figure 33 – Remachining the balance device

9.3.3.6.1 Checking the balance device with bluing ink

After remachining the balance device or fitting new components (601, 602, 525.2) carry out a check with bluing ink.

Coat the axial contact face of the balance disc (601) thinly with bluing ink. Thoroughly clean the axial contact face of the balance counter disc (602). Assemble the

balance device as per item 9.4.3 points 1 to 8, shaft protective sleeve, stuffing Box and bearings as per item 9.4.6 points 1 to 3.

ATTENTION:

Do not fit O rings.

Raise the rotor as per item 4.3.8.

Slowly rotate the rotor pushing it towards the suction side. Then pull the rotor back towards the discharge end of the pump and dismantle all components up to the balance counter disc (602). The contact face of the counter disc should bear an even impression of the bluing ink over its entire area or at least over the outer ¾ of this area. If not, the balance counter disc (602) must be remachined and the ink test repeated.

9.3.3.6 Balancing the rotor

Fitting new rotor components or remachining existing ones means the rotor has to be dynamically balanced at max. operating speed. Max. Residual eccentricity 5 µm.

Rotor assembly:

From the drive end:

Pump sizes 40 and 50

1. Fit the 1st stage key, slide the spacer sleeve (525.1) onto the shaft and over the key.
2. Screw the shaft protecting sleeve (524.1), without O ring onto the shaft.

Pump sizes 65 to 125

3. Fit the spacer sleeve (525.1), insert the key, fit the shaft protecting sleeve (524.1) securing it using the circlip (923.3).

Pump size 150

4. Insert key, fit the shaft protecting sleeve (524.1) securing it using the circlip (923.3).

Pump sizes 40 to 150

5. Insert the key for the coupling hub in the shaft (210) and fit the coupling hub using a suitable device.

From the non-drive end:

Pump sizes 65 to 150

1. Fit the 1st stage impeller key (231) in the shaft (210).

Pump sizes 40 to 150

2. Fit the impellers and the stage sleeves of the subsequent stages in the appropriate sequence on the shaft. Slide the spacer sleeve (525.2) and balance disc (601), without O rings.

Pump sizes 40 and 50

3. Screw the shaft protecting sleeve (524.2) onto the shaft and tighten. Check that the axial clearance between the impeller (230) and shaft protecting sleeve (524.2) is 0,3 mm. Adjust if necessary by remachining the spacer sleeve (525.1) - see fig. 35.

Pump sizes 65 to 150

4. Slip the spacer ring (504.1), onto the shaft, insert the split ring (501) in the shaft groove and secure it with the collar (505.1). Check that the axial clearance between impeller (230) and spacer sleeve (525.2) is 0,3 mm.

5. Fit key in the shaft (210), mount the shaft protecting sleeve (524.1) without O ring, securing it with circlip (932.2).

NOTE:

On pumps with a lifting device (tilting pad thrust bearings type), slide the spacer sleeve (525.3) onto the shaft. Fit key, slide bearing plate (384) and spacer sleeve (525.4)

onto the shaft (210), and secure with bearing nut (920.8), or fix the pinion (87-1) at the shaft end, if the pump has a gear pump coupled to the shaft.

6. Before carrying out dynamic balancing, check the pump rotor at the impellers (impeller wear rings), stage sleeves, balance disc and bearing points for run-out. The value measured should not exceed 0,03 mm.
7. Before final installation dismantle the rotor in the reverse order.

9.3.3.7 Rotor clearances

	As new clearance		Max. permissible clearance	
	Cast iron mm in Ø	Chrome steel mm in Ø	Cast iron mm in Ø	Chrome steel mm in Ø
1st stage ¹⁾ Casing wear ring / Impeller neck	0,45	0,55	1,1	1,1
Casing wear ring / Impeller neck 2 nd stage onwards	0,35	0,45	1,0	1,0
Diffuser / stage sleeve	0,30	0,40	1,0	1,0
Balance counter disc / spacer sleeve	0,45	0,45	1,0	1,0
Shaft / suction casing	1,0	1,0	2,0	2,0

¹⁾ Suction impeller only

Table 05 – Rotor clearances

ATTENTION:

If measured values exceed the max. permissible clearances shown in the “Rotor clearances” – Table 05, new wear parts must be fitted. If new wear parts have to be fitted at one or more points, then all other wear parts must also be renewed to re-establish “as new” clearances throughout the pump.

9.4 Assembly

9.4.1 Assembling the pump

Assemble the pump in accordance with standard engineering practice. Coat the fits of the various components and screw connections with graphite or similar before assembly.

Check all O-rings and shaft seal rings for damage and renew them if necessary. Always fit new gaskets, ensuring they are of the same thickness as the old ones.

NOTE:

Always moisten O-rings before final assembly with silicon fluid or, if not available, with soapy water. Never fit dry O-rings.

The tightening torques indicated for nuts and bolts shall be observed. The table below indicates the tightening torques for threads depending on the materials used.

Property class (Material)	8.8	10.9	A.-50	A.-70	1.4462	1.4462 Tigges A-80
0.2% yield stress $R_{p0.2}$ in $\frac{N}{mm^2}$ ¹⁾	640	900	210	450		624
				250	450	
Metric ISO threads	Tightening torque M_A in Nm					
M6	10.4	14.9	3.40	7.30	10.3	
M8	25.2	36.1	8.30	17.7	25.0	
M10	49.5	71.0	16.2	34.8	49.2	
M12	85.2	122.2	28.0	59.9	84.8	
M16	211	302.7	69.2	148	209.9	
M20	412	591.9	135	290	410.4	

¹⁾ Nominal values to DIN ISO 898 Part 1, DIN 267 Part 11 and DIN 267 Part 18.

Table 06

9.4.1.1 General

Prior to assembly, measure the axial length “E” of the stage casing (108) and the appertaining impeller (230) with stage sleeve (521). Any differences in length must be compensated for solely by machining the stage sleeve (521) so that $E_1 = E_2$ (Fig. 34).

If remachining is necessary, reduce the length of the stage sleeve at both end faces in a single machine tool setting. The permissible deviation from absolute plane parallelism is 5 μ m.

Pump sizes 40 and 50

Check the axial clearance of the rotor components before mounting the rotor. Slip the impellers, stage sleeves, balance disc and spacer sleeves (525.1/2) onto the shaft and tighten both shaft protecting sleeves. The axial clearance should be 0,3 mm (see Fig. 35) if necessary machine the spacer sleeve (525.1) to achieve this. This is generally necessary if replacement spacer sleeves have been fitted.

ATTENTION:

Take care not to damage the contact faces on the stage casings (108), impellers (230 / 231) and stage sleeves (521). Thoroughly clean all pump components, particularly the end contact faces.

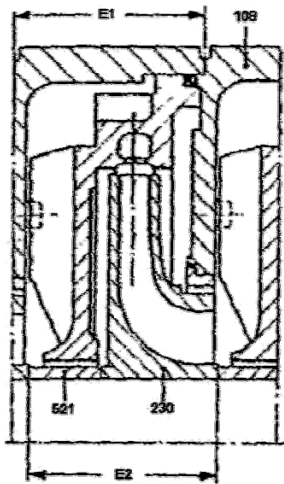

Figure 34 – Measuring stages

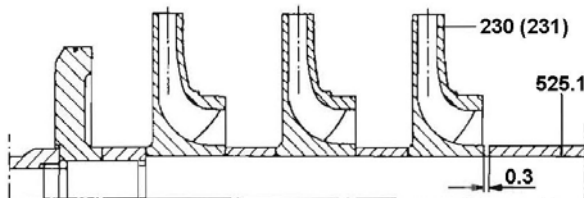

Figure 35 – Axial rotor clearance (sizes 40 and 50)

9.4.2 Assembling the pump

1. Coat the shaft (210) with molybdenum disulphide or a similar approved liquid.

Pump sizes 40 and 50

2. Fit the key for the first stage impeller and slide the spacer sleeve (525.1) onto the shaft and over the key. Screw the shaft protecting sleeve (524.1) with O-ring (412.5) onto the shaft drive end and tighten, checking whether the thread is right – or left – hand. Slide the 1st stage impeller and stage sleeve (521) onto the shaft from the front and insert the shaft into the suction casing (106).

Pump sizes 65 to 125

3. Slip the spacer sleeve (525.1) onto the shaft drive end, fit key, slide the shaft protecting sleeve (524) into position and secure with the circlip (932.3). Check that the axial clearance between shaft shoulder and spacer sleeve (525.1) is 0,5 mm, adjust if necessary.

Pump size 150

4. Insert drive end key, slide the shaft protecting sleeve (524) onto the shaft and fasten with the circlip (932.3). Check that the axial clearance between the shaft protecting sleeve (524.1) and shaft shoulder is 1,0 mm.

Pump sizes 65 to 150

5. Insert the key for 1st stage impeller, slide the impeller (230) and stage sleeve (521) onto the shaft from the non-drive end and insert the shaft in the suction casing (106).

Pump sizes 40 to 150

6. Insert the diffuser (171.1) in the stage casing (108). Mount the stage casing on the suction casing (106). Mount the stage casings in the correct sequence.
7. Mount the other stages in the same way (stage – impeller, stage sleeve and stage casing in succession after assembly).
8. After mounting each stage check the overall axial clearance $Sa_1 + Sa_2$ of the impeller (min. 5 mm) (Fig. 36).

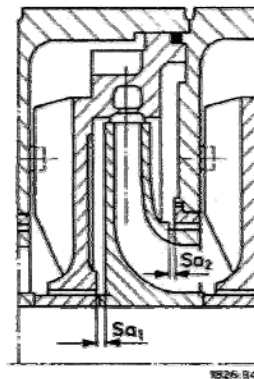

Figure 36 – Total axial clearance

9. Insert final stage diffuser (171.2) in the discharge casing (107).
10. Mount the discharge casing (107) complete with final stage diffuser (171.2) and wear ring (512).
11. Slip discs (550.1) onto the suction end tiebolts (905), screw on and centre nuts (920.1). Insert tiebolts (905) into the casing from the suction side.
12. On the discharge side coat the threads and shims with molybdenum disulphide and tighten the nuts (920.1) by hand using a short standard spanner to ensure metal-to-metal contact of the stage casings (108).
13. Place the pump on its baseplate, ensuring the pump feet seat flush on the baseplate.
14. The tie bolts should be tightened in accordance with the scale graduation marks (slots on tightening nut). Prior to tightening in accordance with the scale graduation marks, the tie bolts have to be pre-loaded with 10 Nm to make sure that the casings have metal-to-metal contact in the axial direction. In addition, the tightening nuts have to be tightened in accordance with the scale graduation marks indicated in the foundation drawing.

9.4.3 Mounting the balance device

Pump sizes 125 to 150

1. If used, insert bush (540), fit the balance counter disc (602) and attach it to the discharge casing (107).

Pump sizes 40 to 100

2. Insert the gasket (400.1) fit the balance counter disc groove (602) in the discharge casing (107) and tighten up the socket head screws (914.1).

Pump sizes 40 and 50

3. Slip the spacer sleeve (525.2) onto the shaft until it abuts. Insert the key and slide the balance disc

- (601) over the shaft until it abuts against the spacer sleeve (525.2).
- Screw shaft protecting sleeve (524.2), and O´ring (412.5) onto the shaft (210), and tighten it. Remember the screw threads may be left-hand or right-hand.
- Pump sizes 65 to 150
- Insert O´ring (412.3), slide the spacer sleeve (525.2) over the shaft and key until it abuts against the impeller. The key of the final stage must engage with the groove of the spacer sleeve (525.2).
 - Insert the O´ring (412.3) in the groove of the balance disc (601). Fit the key in the shaft groove and slide the balance disc over the shaft until it abuts against the spacer sleeve (525.2).
 - Dimension the spacer ring (504.1) as per item 9.4.4. "Rotor adjustment".
 - Slip the spacer ring (504.1), onto the shaft, insert the split ring (501) in the shaft groove and slide the collar (505.1) over it.

NOTE:

See section 9.3.3.6.1 "Bluing ink check".

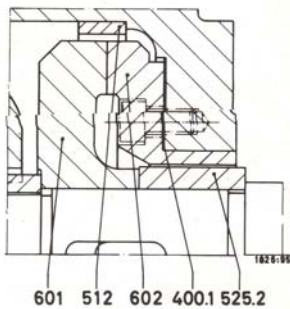

Pump sizes 40 and 50
Figure 37A

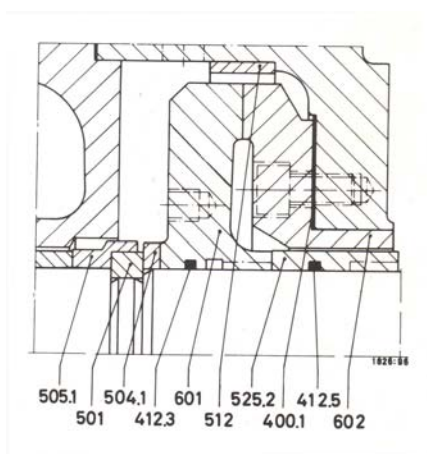

Pump sizes 65 to 100
Figure 37B

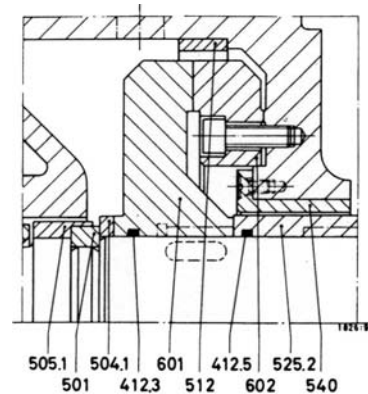

Pump sizes 125 and 150
Figure 37C

9.4.4 Adjusting the rotor

Preparations:

Sizes 40 to 150

Suction discharge and stage casings are held together with tiebolts, the balance counter disc (602) is fitted into the discharge casing (107) and perfectly clean gasket (400.1). The gasket (400.1) is not used on sizes 125 and 150.

Lean the set preliminarily towards the pump discharge end (pressure), and then push it back 2 mm in the suction side, according to figure 38.

ATTENTION:

This rotor position must not be altered during the measurements which follow.

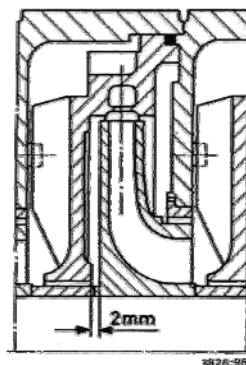

Figure 38 – Rotor position at start of measurements

Rotor adjustment

Measure the distance "a" from the contact face of the balance counter disc (602) to the final stage impeller hub (Fig. 39).

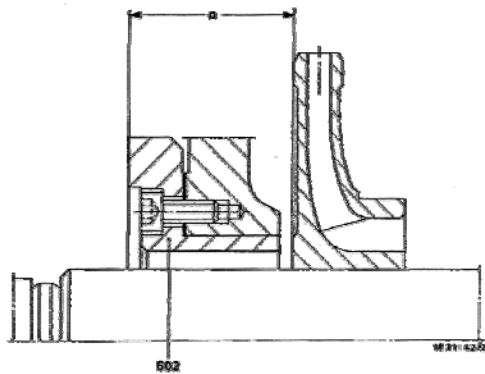

Figure 39 – Rotor adjustment, distance “a”

Then measure distance “b” from the contact face of the balance disc (601), dismantled, to the end of the spacer (525.2) (Fig. 40).

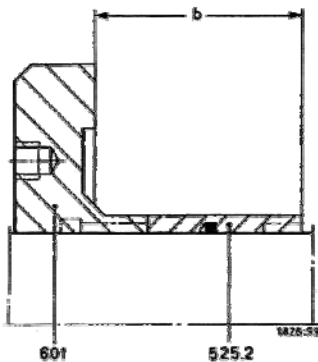

Figure 40 – Rotor adjustment, distance “b”

Shorten the spacer (525.2) so that the measures are equivalents: $a = b$.

Pump sizes 40 and 50

Consult item 9.4.1.1. “General” and Fig. 34.

Pump sizes 65 to 150

Shorten spacer ring (504.1) ensuring that plane parallelism is maintained, so that there is axial clearance between the split ring (501) and the spacer ring (504.1) of:

0,3 mm on sizes 65 to 125

0,5 mm on size 150

Deviation from absolute plane parallelism must not exceed 0,005 mm.

For details of final assembly see section “Mounting the balance device”.

9.4.5 Fitting the shaft seal

Pump sizes 65 to 150

1. Insert the key and slip the shaft protecting sleeve (524), with O ring (412.5) onto the shaft.

Pump sizes 40 to 150

2. Mount the stuffing box housing (451) and gasket (400.3).
3. Insert O ring (412.5). Mount the cooling cover (165) and gasket (400.2) and insert the studs for the gland cover.

4. Slide the gland cover (452.1) over the shaft protecting sleeve (524.1), do not insert it in the stuffing box.
5. Slip thrower (507.1) and / or bearing cover (423), bearing internal side, onto the shaft, if they are part of the supply.

ATTENTION

- Do not pack the gland until just before commissioning after final alignment has been carried out.
- If the pump is supplied with mechanical seals, consider the manufacturer recommendation or specific documentation to install them.

9.4.6 Bearing assembly

1. Insert the bearing isolator (423.2 and 423.3) on the shaft.
 2. Fit the bottom part of the bearing housing (350).
 3. Screw in the lower bearing shells (370) between shaft (210) and bearing housing.
Insert the bearing isolator (423.1) on the shaft.
Mount the coupling hub using a suitable device (see Fig. 46).
 4. Raise the rotor (see section 9.4.8. “Rotor lift”).
 5. Mount the upper bearing shell (370), bearing end cover (361) and upper bearing housing (350).
Fasten the bearing housing using tapered pins.
Bore and ream the holes if necessary.
 6. Mount the rotor position indicator (623.1) plus actuating pin (624) on the discharge end.
 7. Check the markings on the rotor position indicator with the balance disc (601) in contact with the balance counter disc (602), if necessary make a new marking (see section 9.1.1 – Rotor position indicator).
 8. If the pump is supplied with lift-off device in the bearing casing according to figures 41A, 41B, 42 and 43 and follow sequence of items 5 and 6 above.
- If also a gear pump directly connected to the pump shaft is supplied, consider for assembly, the details indicated in the figure 44.

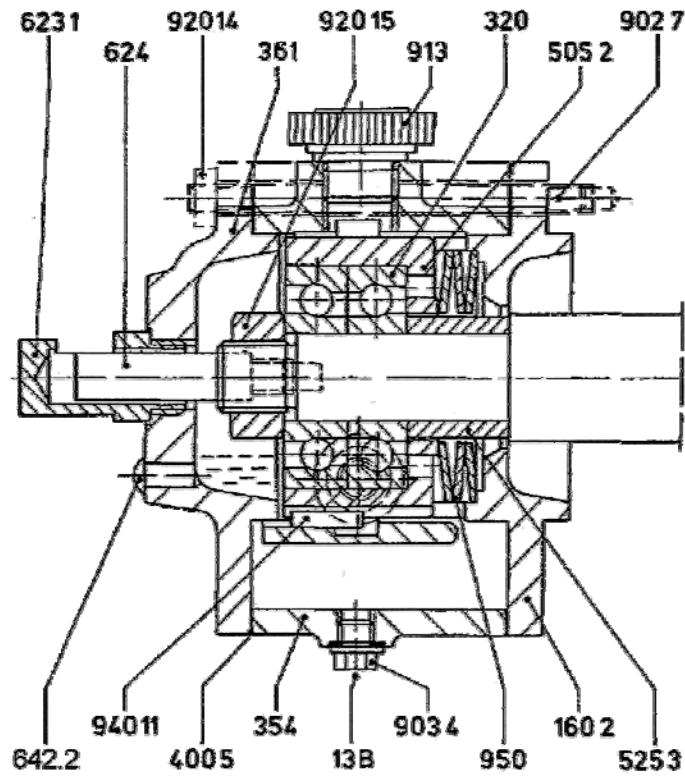

Figure 41A – Lift-off device: anti-friction bearings
 Pump: anti-friction bearings

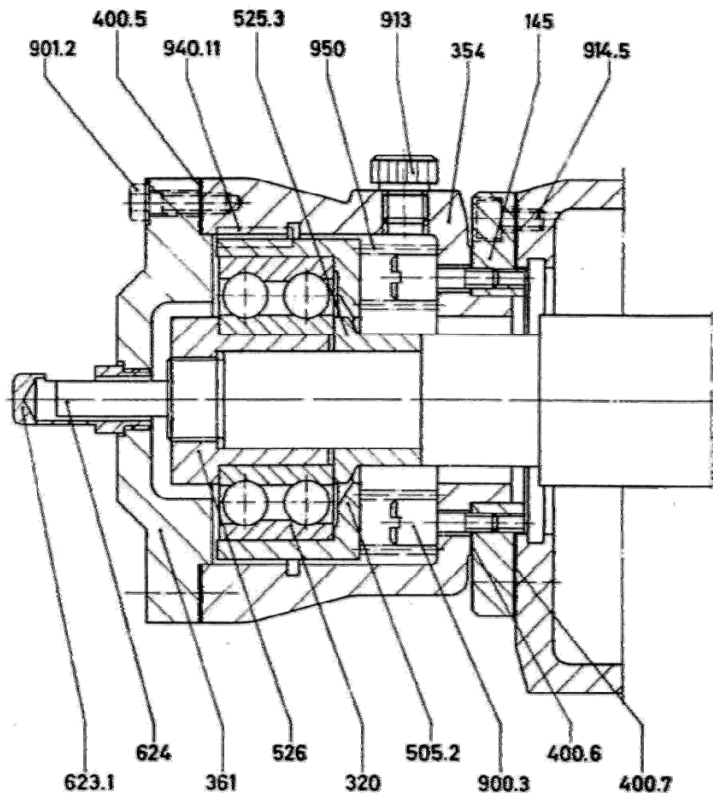

Figure 41B – Lift-off device: anti-friction bearings
 Pump: plain bearings with ring oil lubrication

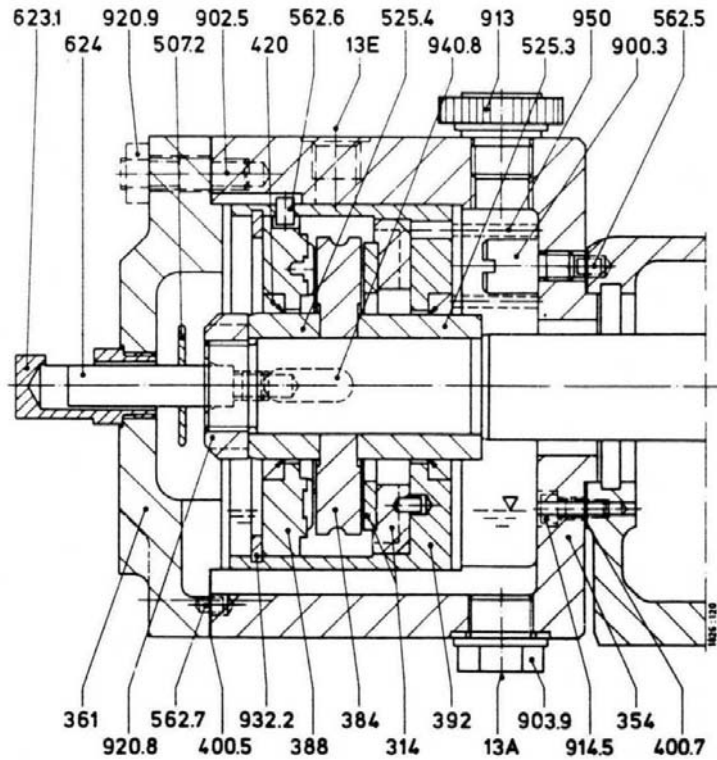

Figure 42 – Lift-off device: segmental thrust bearing
 Pump sizes 40 to 125: plain bearings with force oil lubrication

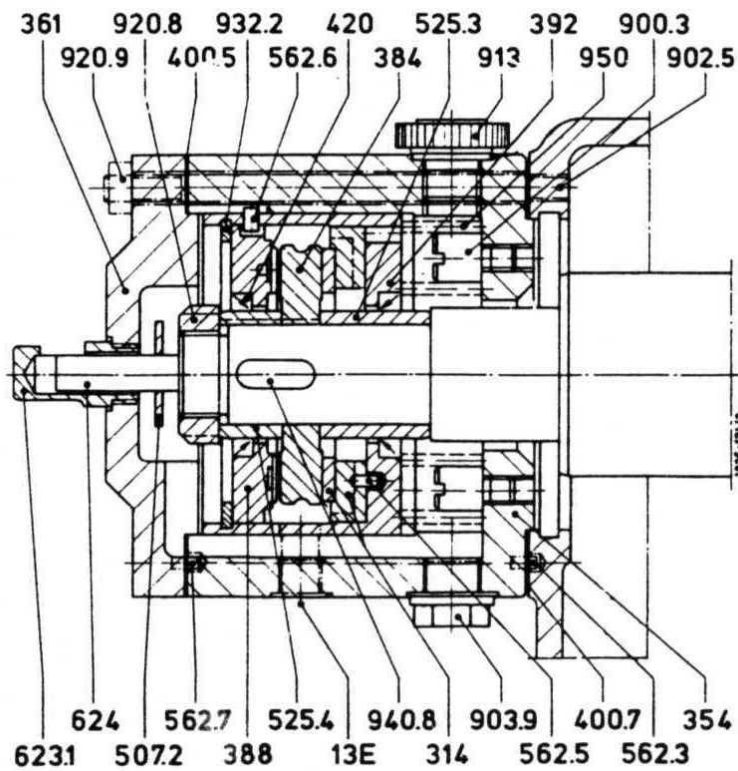

Figure 43 – Lift-off device: segmental thrust bearing
 Pump size 150: plain bearing with force oil lubrication

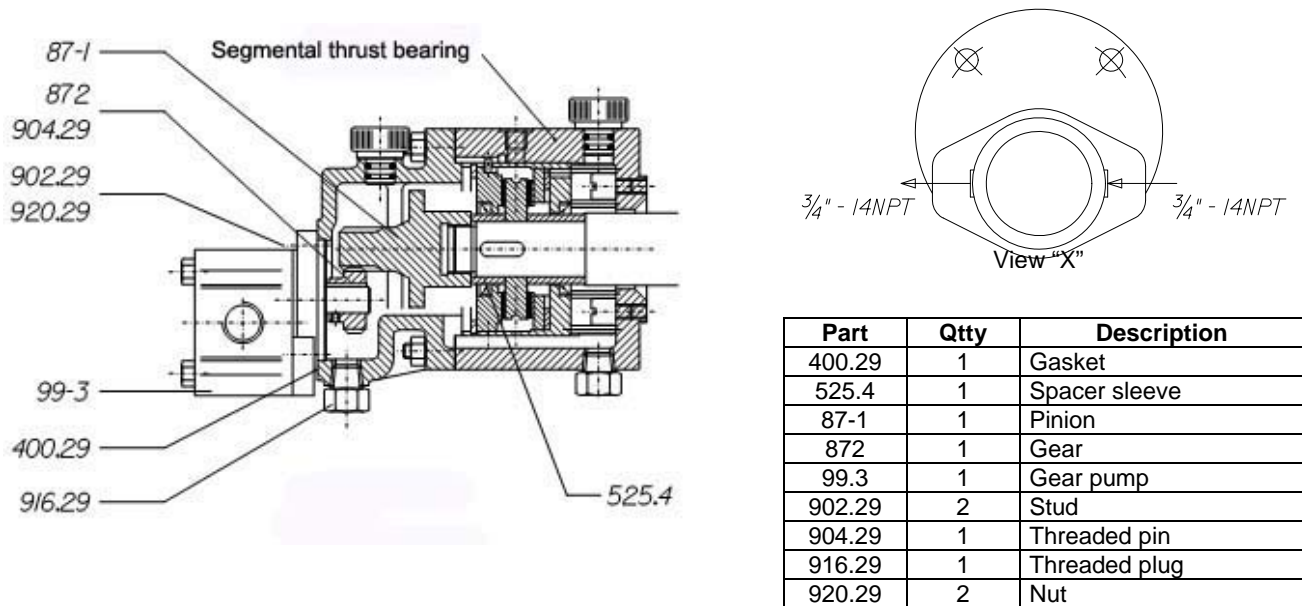

Figure 44 - Gear pump

Gear pump parts

9.4.7 Coupling (See item 8.3)

Wherever possible, use a special device to fit and pull off couplings (see Fig. 45 and 46). To mount the coupling hubs when warm, heat them in an oil bath or on an electric hotplate (temperature between 80-100 °C).

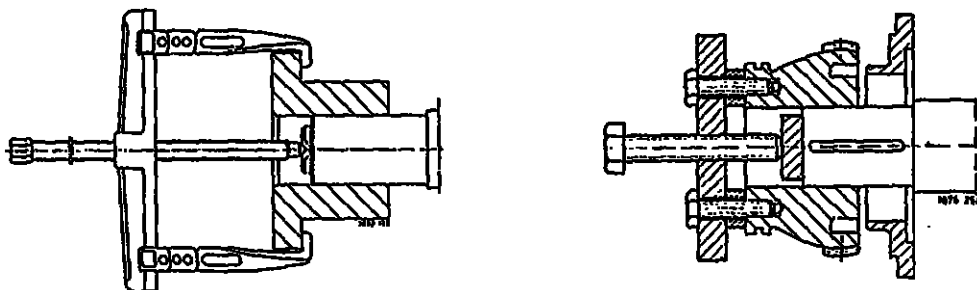

Figure 45 – Pulling off the coupling hub

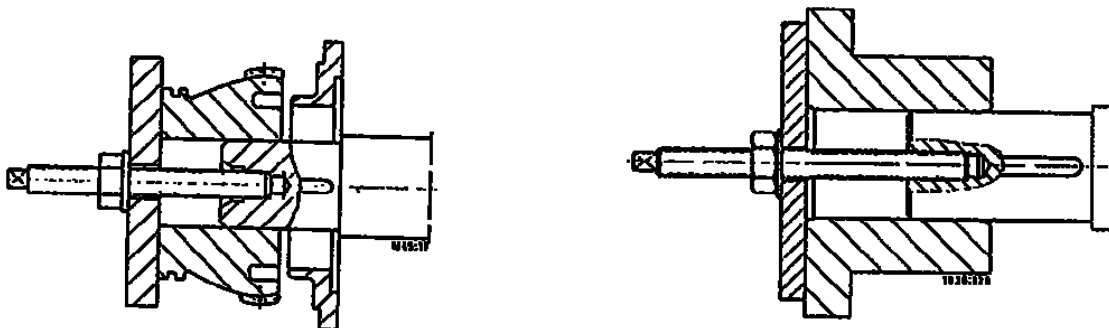

Figure 46 – Mounting the coupling hub

9.4.8 Rotor lift

Only carry out this check when the pump has cooled down and with the coupling hub mounted (temperature at nozzles $\leq 50\text{ }^{\circ}\text{C}$).

Laterally align bottom half of the bearing housing (350.1).

Horizontal adjusting screws (901.4) in the bearing housing flange are used for the lateral alignment of the bearing housing.

The lateral alignment of the pump can be considered satisfactory if the lower bearing shell (370) can be moved in its seating by hand without undue effort from either end between the shaft (210) and bottom half of the bearing housing (350). If the check reveals increased clearances between pump rotor and pump casing within the permitted limits, add half the radial increase to the "lift dimension" shown on the upper part of the bearing housing.

Fit dial indicators on the shaft (210) (suction and discharge sides) with the rotor in "zero" position ("zero"

position means with both radial bearings removed – lift is based on this condition).

Insert the lower bearing shells (370) at the suction and discharge sides and read off the vertical rise of the rotor on the dial indicators.

The rotor should move upwards by half the radial rotor clearance + 0,05 to 0,1 mm.

Check the measurement by taking out and re-inserting the bottom bearing shells (370). The measurement should correspond to the initial value.

Use a piece of wood to facilitate insertion of the bottom bearing shells. Note the lift values. The rotor can be aligned vertically by means of the adjusting screw (901.4) at the top of the bearing housing flange.

9.5 Spare parts

When ordering spare parts always quote the part n° and serial number. The serial number is shown on the front page of this manual and on the pump nameplate.

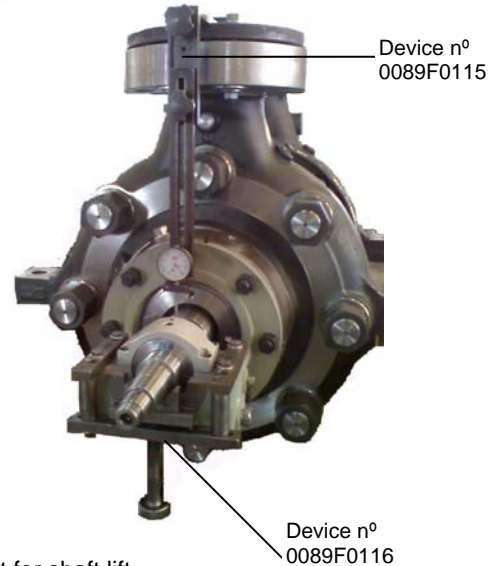
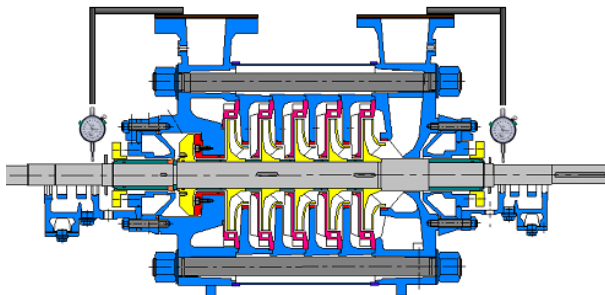

Fig. 47 – Dial indicator arrangement for shaft lift

9.5.1 Spare parts

PART	DENOMINATION	QTTY	REMARKS
210	SHAFT	1	
230	IMPELLER	n	
231	SUCTION STAGE IMPELLER	1	ONLY ON PUMP SIZE 150
370	BEARING SHELL	2	ON PUMP SIZE 150 PART N° 370.1/2
400.1	GASKET	1	
400.2	GASKET	2	
400.3	GASKET	2	
412.1	O´RING	n	
412.2	O´RING	1	
412.3	O´RING	1	ON PUMP SIZES 65 TO 150 ONLY
412.4	O´RING	2	
412.5	O´RING	2	
412.6	O´RING	1	
412.9	O´RING	2	
461	GLAND PACKING	2	
501	SPLIT RING	1	
502.1	CASING WEAR RING	1	
502.2	CASING WEAR RING	n-1	
503.1	IMPELLER WEAR RING	1	ONLY ON PUMP SIZE 150, IF FITTED
503.2	IMPELLER WEAR RING	5	IF FITTED, AND ON PUMP SIZE 150 QTTY: n-1
504.1	SPACER RING	1	ONLY ON PUMP SIZES 65 TO 150
505.1	COLLAR	1	ONLY ON PUMP SIZES 65 TO 150
521	STAGE SLEEVE	n-1	
524.1	SHAFT PROTECTING SLEEVE	2 (1)	(1) ONLY ON PUMP SIZES 40 AND 50
524.2	SHAFT PROTECTING SLEEVE	1	ONLY ON PUMP SIZES 40 AND 50
525.1	SPACER SLEEVE	1	
525.2	SPACER SLEEVE	1	
540	BUSH	1	ONLY ON PUMP SIZES 125 AND 150
541	STAGE BUSH	n-1	IF FITTED
601	BALANCE DISC	1	
602	BALANCE COUNTER DISC	1	
932.3	CIRCLIP	2	ONLY ON PUMP SIZES 65 TO 150

n = N° of stages

9.6 Sectional drawing and part list please see the drawing and part list sent together with product data book.

10. Faults and causes

Pump delivers insufficient flow rate	Motor is overloaded	Excessive pump discharge pressure	Increase in bearing temperature	Leakage at the pump	Excessive leakage at the shaft seal	Vibration during pump operation	Excessive rise of temperature inside the	Rough pump running	Pressure quantity of balance liquid varies	Cause	Remedy ¹⁾
•										Pump delivers against an excessively high discharge pressure.	Re-adjust duty point.
•										Excessively high back pressure.	Check plant for impurities. Increase the speed (turbine, I.C. engine).
•						•	•	•	•	Pump or piping are not completely vented or primed.	Vent and/or prime.
•										Supply line or impeller clogged.	Remove deposits in the pump and/or piping.
•										Formation of air pockets in the piping.	Alter piping layout. /Fit a vent valve.
	•		•		•	•				Pump is warped or sympathetic vibrations in the piping.	Check pipeline connection and secure fixing of pump; if required reduced the distance between the pipe clamps. Fix the pipelines using anti-vibration material.
•						•	•	•	•	Suction head is too high / NPSH available (positive suction head) is too low.	Check / alter liquid level. /Fully open shut-off valve in the suction head line. /Change suction line, if friction losses in the suction line are too high. Check any strainers installed / suction opening. Observe permissible speed of pressure fall.
			•						•	Increased axial thrust. ²⁾	Correct rotor adjustment.
•										Air intake at the shaft seal.	Fit new shaft seal. /Clean liquid passage. Arrange a sealing liquid supply from an outside source. /Or increase sealing liquid pressure.
•										Reverse rotation	Interchange two of the phases of the power supply cable.
•	•									Motor is running on two phases only.	Replace the defective fuse. Check the electric cable connections.
•									•	Speed is too low. ²⁾	Increase speed.
						•			•	Defective bearings.	Fit new bearings.
			•			•	•	•		Insufficient rate of flow.	Increase the minimum rate of flow.
•	•					•			•	Wear of internal pump parts.	Replace worn components by new ones.
	•					•				Pump back pressure is lower than specified in the purchase order.	Adjust duty point accurately. /Trim the impellers.
	•									Density or viscosity of the fluid pumped is higher than stated in the purchase order. ²⁾	
	•				•					Use of unsuitable materials.	Change the Material combination.
	•	•								Speed is too high.	Reduce the speed. ²⁾ (applies to turbine driven or I.C. engine driven pumps) ^{2) 3)}
	•			•						Tie bolts/seals and gaskets.	Tighten the bolts. /Fit new seals and gaskets.
					•					Worn shaft seal.	Fit new shaft seal.
•					•					Score marks or roughness on shaft protecting sleeve.	Fit new shaft protecting sleeve. Fit new shaft seal / check the balancing line. Check the throttle bush / throttling sleeve clearances.
					•					Lack of cooling liquid or dirty cooling chamber.	Increase cooling liquid quantity. /Clean out cooling chamber. /Purify / clean cooling liquid.
					•					Vibrations during pump operation.	Improve suction conditions. /Re-align the pump. /Re-balance the impeller. /Increase the pressure at the pump suction nozzle.
			•		•	•			•	The unit is misaligned.	Check the coupling; re-align, if required.
			•						•	Insufficient or excessive quantity of lubricant or unsuitable lubricant.	Top up, reduce or change lubricant.
			•							Non-compliance with specified coupling distance.	Correct distance according to the G.A. Drawing.
	•									Operating voltage is too low.	Increase the voltage.
						•			•	Rotor is out of balance .	Clean the impeller. /Re-balance the impeller.
									•	Check balance liquid line	Check mode of pump running. /Check return line. /Check pump pressures. / Check rotor clearances and balancing device.

1) The pump pressure must be released before attempting to remedy faults on parts which are subjected to pressure.

2) Contact KSB.

3) This fault can also overcome by modifying the impeller diameter.

ATTACHMENT I - START-UP CHECK LIST

		YES	NO	N.A.
	Rev.1			
	CUSTOMER:			
	PUMP:			
	DRIVER:			
	OP:			
	TAG:			
	SERVICE:			
	SEAL PLAN:			
1	Hydraulic check list			
1.1	Is the suction valve fully open? And are all blanking plates removed?			
1.2	Is there liquid available to pump (suction valve is opened)?			
1.3	Is the liquid in a condition to flow freely?			
1.4	Is the suction flow path complete?			
1.5	Is the suction line connection to the supply vessel submerged enough to prevent the formation of air-entraining vortices?			
1.6	Are the suction strainers correctly sized?			
1.7	Are there provisions to measure the pressure drop through the strainer as and indication of clogging?			
1.8	Is the suction pressure adequate to provide enough NPSH?			
1.9	If this pump has a suction booster pump, do the suction pressure readings of this pump correct?			
1.10	Will the discharge line stay full once the pump shuts down?			
1.11	Is the pump primed?			
1.12	Is the pump vented and are the vent valves open? Has pump been slowly turned over by hand to clear impeller passages?			
1.13	Pumps handling hot liquid must be warmed-up before starting.			
1.14	Are there facilities available for measurement of pump flow and pump power consumption (amps) as an aid to future diagnostics?			
1.15	Are there tapings available for measurement of suction and discharge pressure as an aid to future diagnostics?			
1.16	Is the minimum flow bypass open? (where provided)			
1.17	Is the automatic re-cycle valve open? (where provided)			
1.18	Is the discharge line resistance sufficient for start up? (As a default aim for a valve opening of less than 20%)			
1.19	Is the discharge line empty?			
1.20	Is the discharge line likely to get damaged during operation?			
1.21	Could reverse flow take place in the system?			
1.22	If the pump is of the type that uses an external hydraulic balancing line, are you sure that no obstructions can occur?			

		YES	NO	N.A.
	Rev.1			
	CUSTOMER:			
	PUMP:			
	DRIVER:			
	OP:			
	TAG:			
	SERVICE:			
	SEAL PLAN:			
2	Mechanical check list			
2.1	Is foundation block sufficiently massive?			
2.2	Is the baseplate pedestal cooling turned on (where fitted)?			
2.3	Is the warm-up system (where installed) functioning correctly?			
2.4	Does the alignment change when the pump and pipes are filled with liquid?			
2.5	Does the alignment change significantly after the pump has warmed to its operating temperature?			
2.6	Was the flange alignment checked before and after bolt-up?			
2.7	When cold, can the rotor be easily turned with (relative) ease, and without metallic sounds?			
2.8	Is "bump" start motor to check rotation correct?			
2.9	If variable speed drive is used, please ensure minimum speed is above first critical of multistage pump-typically more than 2000 rpm.			
2.10	Check for any mechanical "looseness".			
2.11	Check oil ring (where fitted) is located centrally and has not become dislodged.			
2.12	Check static oil level or constant level oiler, where fitted.			
2.13	If grease lubricated, make sure not over packed.			
2.14	Where fitted, is grease visible from the relief valve? Does the grease look old or new?			
2.15	If a constant level oiler is fitted, is the pump in a fixed installation.			
2.16	Check cooling water to bearings-where provided.			
2.17	If pump is soft packed, check that gland bolts are only very slightly tight.			
2.18	If softy packed pump is on a suction lift, ensure packing will be flooded with liquid during start up and operation.			
2.19	Is the coupling guard secure?			
2.20	Was it verified that the seal chamber is vented?			
2.21	Pumps handling hot liquids must be warmed-up before starting.			
2.22	In case of dual seals, can the barrier liquid pressure be monitored? (As an aid to diagnosis a failure on primary seal).			
2.23	In case of dual seals, can the barrier liquid temperature (in and out) be monitored? As an aid to diagnosis a failure on primary seal).			
2.24	In case of dual seals, can it be proven that the barrier liquid pressure exceeds the suction pressure BEFORE start up?			
2.25	Verify oil mist venting from bearings of oil mist system, if applicable.			
2.26	In case of multistage pumps (HDA, HDB) with extraction lines, they should be always opened if recommended on pump data-sheet.			

		YES	NO	N.A.
	Rev.1			
	CUSTOMER:			
	PUMP:			
	DRIVER:			
	OP:			
	TAG:			
	SERVICE:			
	SEAL PLAN:			
3	Accessories check list			
3.1	In case of ARC valve are they correctly fitted?			
3.2	In case of multistage pumps (HDA, HDB, WL) with balancing lines returning to the suction tank is the safety (relief) valve correctly set-up?			
3.3	In case of pressurized lube oil system (ULF) to the bearings following items should be checked: <ul style="list-style-type: none"> - is outlet pressure of ULF correct? Check driver rotation direction - are leakages on supply and return lines of ULF and bearings? - if applicable, check inlet and outlet temperatures of water cooling of heat exchanger. - control and monitoring devices (pressure switches and gages temperature switches and gages flow switches, etc) are correct set-up and running? 			
3.4	In case of multistage pump HDB with gear pump directly coupled to the shaft it is required to check the pressure delivered on lubrication lines during operation.			
3.5	For others accessories (electric motor, turbine, mechanical seals, valves, couplings, speed variable drivers, etc) is recommended to verify the specific requirements of operation / maintenance of each one.			

25.03.2010

A1826.8E/1

KSB Bombas Hidráulicas SA
Rua José Rabello Portella, 400
Várzea Paulista SP 13220-540
Brazil <http://www.ksb.com>
phone.: 55 11 4596 8500 Fax: 55 11 4596 8580
SAK – KSB Customer Service
e-mail: gqualidade@ksb.com.br
Fax: 55 11 4596 8656