

High-pressure In-line Pump

Movitec

Installation/Operating Manual



CE

KSB 

Legal information/Copyright

Installation/Operating Manual Movitec

Original operating manual

All rights reserved. The contents provided herein must neither be distributed, copied, reproduced, edited or processed for any other purpose, nor otherwise transmitted, published or made available to a third party without the manufacturer's express written consent.

Subject to technical modification without prior notice.

© KSB B.V., Alphen aan den Rijn, Nederland 2023-01-12

Contents

	Glossary	5
1	General.....	6
	1.1 Principles	6
	1.2 Installation of partly completed machinery.....	6
	1.3 Target group.....	6
	1.4 Other applicable documents.....	6
	1.5 Symbols	6
	1.6 Key to safety symbols/markings.....	7
2	Safety	8
	2.1 General.....	8
	2.2 Intended use	8
	2.3 Personnel qualification and training.....	8
	2.4 Consequences and risks caused by non-compliance with this manual	9
	2.5 Safety awareness	9
	2.6 Safety information for the operator/user	9
	2.7 Safety information for maintenance, inspection and installation	9
	2.8 Unauthorised modes of operation	10
3	Transport/Storage/Disposal	11
	3.1 Checking the condition upon delivery	11
	3.2 Transport.....	11
	3.2.1 Transporting the pump set with frequency inverter	12
	3.3 Storage/preservation	12
	3.4 Disposal	13
	3.5 Return to supplier.....	14
4	Description of the Pump (Set)	15
	4.1 General description	15
	4.2 Product information.....	15
	4.2.1 Product information as per Regulation No. 1907/2006 (REACH)	15
	4.2.2 Product Information as per Regulation No. 547/2012 (for water pumps with a maximum shaft power of 150 kW) implementing "Ecodesign" Directive 2009/125/EC.....	15
	4.3 Designation.....	16
	4.4 Name plate.....	20
	4.5 Design details.....	21
	4.6 Configuration and function.....	22
	4.7 Noise characteristics	22
	4.8 Scope of supply.....	22
	4.9 Dimensions and weights	22
5	Installation at Site	23
	5.1 Safety regulations.....	23
	5.2 Checks to be carried out prior to installation.....	23
	5.3 Installing the pump set	24
	5.4 Piping	24
	5.4.1 Connecting the piping	24
	5.4.2 Permissible forces and moments at the pump nozzles.....	26
	5.5 Fitting a bypass	27
	5.6 Electrical connection	27
	5.6.1 Overload protection	28
	5.6.2 Earthing	29
	5.7 Checking the direction of rotation.....	29
6	Commissioning/Start-up/Shutdown.....	31
	6.1 Commissioning/Start-up.....	31
	6.1.1 Prerequisites for commissioning/start-up	31

6.1.2	Priming and venting the pump.....	31
6.1.3	Checking the shaft seal.....	33
6.2	Operating limits.....	33
6.2.1	Pressure limits and temperature limits.....	34
6.2.2	Rated current and maximum current.....	37
6.2.3	Fluid handled.....	37
6.3	Shutdown/storage/preservation.....	39
6.3.1	Measures to be taken for shutdown.....	39
6.4	Returning to service.....	39
7	Servicing/Maintenance.....	40
7.1	Safety regulations.....	40
7.2	Servicing/inspection.....	41
7.2.1	Supervision of operation.....	41
7.2.2	Lubrication and lubricant change.....	42
7.3	Drainage/cleaning.....	43
7.4	Dismantling the pump set.....	44
7.4.1	General information/Safety regulations.....	44
7.4.2	Preparing the pump set.....	45
7.4.3	Removing the motor.....	45
7.4.4	Removing the retaining bracket (optional).....	47
7.4.5	Removing the mechanical seal.....	48
7.5	Reassembling the pump set.....	49
7.5.1	General information/Safety regulations.....	49
7.5.2	Installing the mechanical seal.....	50
7.5.3	Mounting the motor.....	52
7.5.4	Adjusting the mechanical seal, coupling and pump shaft.....	54
7.6	Tightening torques.....	56
7.7	Spare parts stock.....	57
7.7.1	Ordering spare parts.....	57
8	Trouble-shooting.....	58
9	Related Documents.....	60
9.1	General assembly drawings/exploded views with list of components.....	60
9.1.1	Movitec 2(L)B, 4(L)B, 6(L)B.....	60
9.1.2	Movitec 10(L)B, 15(L)B.....	61
9.1.3	Movitec 15(L)C.....	62
9.1.4	Movitec 25B.....	63
9.1.5	Movitec 40B, 60B.....	64
9.1.6	Movitec 90B.....	65
9.1.7	Movitec 125B.....	67
9.1.8	Movitec LHS.....	68
9.1.9	Motor.....	69
9.2	Wiring diagram.....	70
10	EU Declaration of Conformity.....	72
11	Certificate of Decontamination.....	73
	Index.....	74

Glossary

Certificate of decontamination

A certificate of decontamination is enclosed by the customer when returning the product to the manufacturer to certify that the product has been properly drained to eliminate any environmental and health hazards arising from components in contact with the fluid handled.

Discharge line

The pipeline which is connected to the discharge nozzle

Hydraulic system

The part of the pump in which the kinetic energy is converted into pressure energy

IE3

Efficiency class to IEC 60034-30: 3 = Premium Efficiency (IE = International Efficiency)

IE4

Efficiency class to IEC TS 60034-30-2:2016 = Super Premium Efficiency (IE = International Efficiency)

IE5

Efficiency class to IEC TS 60034-30-2:2016 = Ultra Premium Efficiency (IE = International Efficiency)

Noise characteristics

The noise characteristics are indicated as surface sound pressure level in dB(A).

Pump

Machine without drive, additional components or accessories

Pump set

Complete pump set consisting of pump, drive, additional components and accessories

Suction lift line/suction head line

The pipeline which is connected to the suction nozzle

1 General

1.1 Principles

This operating manual is valid for the type series and variants indicated on the front cover.

The operating manual describes the proper and safe use of this equipment in all phases of operation.

The name plate indicates the type series, the main operating data and the serial number. The serial number uniquely describes the product and is used as identification in all further business processes.

In the event of damage, immediately contact your nearest KSB service facility to maintain the right to claim under warranty.

1.2 Installation of partly completed machinery

To install partly completed machinery supplied by KSB refer to the sub-sections under Servicing/Maintenance.

1.3 Target group

This operating manual is aimed at the target group of trained and qualified specialist technical personnel. (⇒ Section 2.3, Page 8)

1.4 Other applicable documents

Table 1: Overview of other applicable documents

Document	Contents
Data sheet	Description of the technical data of the pump (set)
General arrangement drawing / outline drawing	Description of mating dimensions and installation dimensions for the pump (set), weights
Drawing of auxiliary connections	Description of auxiliary connections
Hydraulic characteristic curve	Characteristic curves showing head, NPSH required, efficiency and power input
General assembly drawing ¹⁾	Sectional drawing of the pump
Sub-supplier product literature ¹⁾	Operating manuals and other product literature describing accessories and integrated machinery components
Spare parts lists ¹⁾	Description of spare parts
Piping layout ¹⁾	Description of auxiliary piping
List of components ¹⁾	Description of all pump components
Assembly drawing ¹⁾	Sectional drawing of the installed shaft seal

For accessories and/or integrated machinery components, observe the relevant manufacturer's product literature.

1.5 Symbols

Table 2: Symbols used in this manual





Symbol	Description
✓	Conditions which need to be fulfilled before proceeding with the step-by-step instructions
▷	Safety instructions
⇨	Result of an action
⇔	Cross-references

¹ If included in agreed scope of supply

Symbol	Description
1. 2.	Step-by-step instructions
	Note Recommendations and important information on how to handle the product

1.6 Key to safety symbols/markings

Table 3: Definition of safety symbols/markings

Symbol	Description
 DANGER	DANGER This signal word indicates a high-risk hazard which, if not avoided, will result in death or serious injury.
 WARNING	WARNING This signal word indicates a medium-risk hazard which, if not avoided, could result in death or serious injury.
CAUTION	CAUTION This signal word indicates a hazard which, if not avoided, could result in damage to the machine and its functions.
	General hazard In conjunction with one of the signal words this symbol indicates a hazard which will or could result in death or serious injury.
	Electrical hazard In conjunction with one of the signal words this symbol indicates a hazard involving electrical voltage and identifies information about protection against electrical voltage.
	Machine damage In conjunction with the signal word CAUTION this symbol indicates a hazard for the machine and its functions.



2 Safety

All the information contained in this section refers to hazardous situations.

In addition to the present general safety information the action-related safety information given in the other sections must be observed.

2.1 General

- This operating manual contains general installation, operating and maintenance instructions that must be observed to ensure safe operation of the system and prevent personal injury and damage to property.
- Comply with all the safety instructions given in the individual sections of this operating manual.
- The operating manual must be read and understood by the responsible specialist personnel/operators prior to installation and commissioning.
- The contents of this operating manual must be available to the specialist personnel at the site at all times.
- Information and markings attached directly to the product must always be complied with and kept in a perfectly legible condition at all times. This applies to, for example:
 - Arrow indicating the direction of rotation
 - Markings for connections
 - Name plate
- The operator is responsible for ensuring compliance with all local regulations not taken into account.

2.2 Intended use

- The pump (set) must only be operated in the fields of application and within the use limits specified in the other applicable documents. (⇒ Section 1.4, Page 6)
- Only operate pumps/pump sets which are in perfect technical condition.
- Do not operate the pump (set) in partially assembled condition.
- Only use the pump (set) to handle the fluids described in the data sheet or product literature of the pump model.
- Never operate the pump (set) without the fluid to be handled.
- Observe the minimum flow rate and maximum flow rate indicated in the data sheet or product literature (to prevent overheating, mechanical seal damage, cavitation damage, bearing damage, etc).
- Always operate the pump (set) in the direction of rotation it is intended for.
- Do not throttle the flow rate on the suction side of the pump (to prevent cavitation damage).
- Consult the manufacturer about any use or mode of operation not described in the data sheet or product literature.

2.3 Personnel qualification and training

All personnel involved must be fully qualified to transport, install, operate, maintain and inspect the machinery this manual refers to.

The responsibilities, competence and supervision of all personnel involved in transport, installation, operation, maintenance and inspection must be clearly defined by the operator.

Deficits in knowledge must be rectified by means of training and instruction provided by sufficiently trained specialist personnel. If required, the operator can commission the manufacturer/supplier to train the personnel.

Training on the pump (set) must always be supervised by technical specialist personnel.

2.4 Consequences and risks caused by non-compliance with this manual

- Non-compliance with these operating instructions will lead to forfeiture of warranty cover and of any and all rights to claims for damages.
- Non-compliance can, for example, have the following consequences:
 - Hazards to persons due to electrical, thermal, mechanical and chemical effects and explosions
 - Failure of important product functions
 - Failure of prescribed maintenance and servicing practices
 - Hazard to the environment due to leakage of hazardous substances

2.5 Safety awareness

In addition to the safety information contained in this operating manual and the intended use, the following safety regulations shall be complied with:

- Accident prevention, health regulations and safety regulations
- Explosion protection regulations
- Safety regulations for handling hazardous substances
- Applicable standards, directives and laws

2.6 Safety information for the operator/user

- Fit protective equipment (e.g. contact guards) supplied by the operator for hot, cold or moving parts, and check that the equipment functions properly.
- Do not remove any protective equipment (e.g. contact guards) during operation.
- Provide the personnel with protective equipment and make sure it is used.
- Contain leakages (e.g. at the shaft seal) of hazardous fluids handled (e.g. explosive, toxic, hot) so as to avoid any danger to persons and the environment. Adhere to all relevant laws.
- Eliminate all electrical hazards. (In this respect refer to the applicable national safety regulations and/or regulations issued by the local energy supply companies.)
- If stopping the pump does not increase potential risk, fit an emergency-stop control device in the immediate vicinity of the pump (set) during pump set installation.

2.7 Safety information for maintenance, inspection and installation

- Modifications or alterations of the pump (set) are only permitted with the manufacturer's prior consent.
- Use only original spare parts or parts/components authorised by the manufacturer. The use of other parts/components can invalidate any liability of the manufacturer for resulting damage.
- The operator ensures that maintenance, inspection and installation are performed by authorised, qualified specialist personnel who are thoroughly familiar with the manual.
- Only carry out work on the pump (set) during standstill of the pump.
- Only perform work on the pump set when it has been disconnected from the power supply (de-energised).
- The pump (set) must have cooled down to ambient temperature.
- Pump pressure must have been released and the pump must have been drained.

- When taking the pump set out of service always adhere to the procedure described in the manual. (⇒ Section 6.3, Page 39)
- Decontaminate pumps which handle fluids posing a health hazard.
- As soon as the work has been completed, re-install and re-activate any safety-relevant devices and protective devices. Before returning the product to service, observe all instructions on commissioning. (⇒ Section 6.1, Page 31)

2.8 Unauthorised modes of operation

Never operate the pump (set) outside the limits stated in the data sheet and in this manual.

The warranty relating to the operating reliability and safety of the supplied pump (set) is only valid if the equipment is used in accordance with its intended use. (⇒ Section 2.2, Page 8)





3 Transport/Storage/Disposal

3.1 Checking the condition upon delivery

1. On transfer of goods, check each packaging unit for damage.
2. In the event of in-transit damage, assess the exact damage, document it and notify KSB or the supplying dealer and the insurer about the damage in writing immediately.

3.2 Transport

Transporting the pump set

	 DANGER
	<p>Improper transport Danger to life from falling parts! Damage to the pump set!</p> <ul style="list-style-type: none"> ▷ Use the attachment point provided for attaching the lifting accessory. ▷ Never suspend the pump set by its power cable. ▷ Use the lifting chain/rope included in the scope of supply exclusively for lowering or lifting the pump set into/out of the pump sump. ▷ Securely attach the lifting chain/rope to the pump and crane. ▷ Use tested, marked and approved lifting accessories only. ▷ Observe the regional transport regulations. ▷ Observe the product literature supplied by the lifting accessory manufacturer. ▷ The load-carrying capacity of the lifting accessory must be higher than the weight indicated on the name plate of the pump set to be lifted. Take into account any additional system components to be lifted.
	 WARNING
	<p>Improper lifting/moving of heavy assemblies or components Personal injury and damage to property!</p> <ul style="list-style-type: none"> ▷ Use suitable transport devices, lifting equipment and lifting tackle to move heavy assemblies or components.

To transport the pump/pump set suspend it from the lifting tackle as shown.

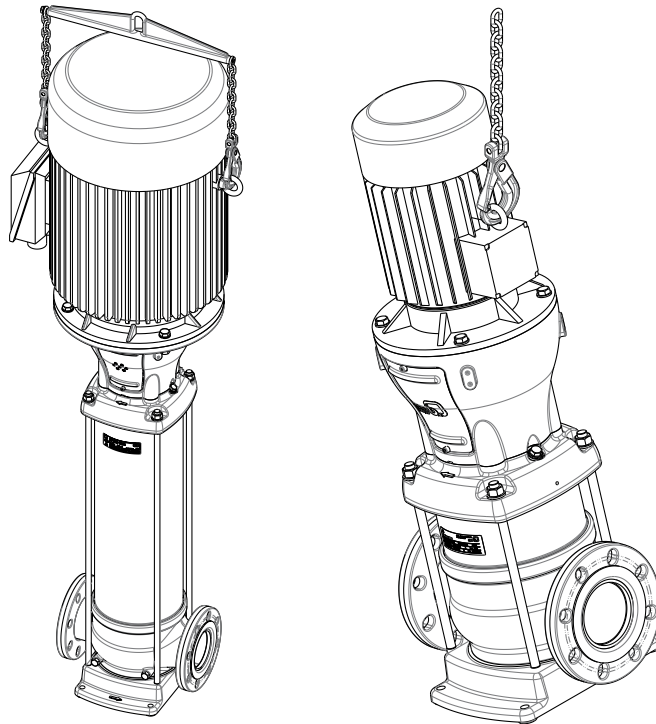

Fig. 1: Transporting the pump set

Placing down the pump set

	<p>⚠ WARNING</p>
	<p>Incorrect positioning/placing down Personal injury and damage to property!</p> <ul style="list-style-type: none"> ▶ Position the pump set vertically with the motor on top. ▶ Use appropriate means to secure the pump set against tilting and tipping over. ▶ Refer to the weights given in the data sheet/on the name plate.

3.2.1 Transporting the pump set with frequency inverter

	<p>⚠ WARNING</p>
	<p>Improper lifting/moving of heavy assemblies or components Personal injury and damage to property!</p> <ul style="list-style-type: none"> ▶ Have this work performed exclusively by trained personnel. ▶ Observe the product literature provided by the frequency inverter's manufacturer, especially for installation and transport.

Pump sets with a frequency inverter are dispatched as follows:

- **Frequency inverter ≤ 7.5 kW**
 The frequency inverter is mounted on the motor prior to dispatch.
- **Frequency inverter > 7.5 kW**
 The frequency inverter is dispatched separately to prevent the risk of the pump set tipping over.

3.3 Storage/preservation

If commissioning is to take place some time after delivery, take the following measures:

	CAUTION
	<p>Damage during storage due to humidity, dirt or vermin Corrosion/contamination of the pump (set)!</p> <ul style="list-style-type: none"> ▷ For outdoor storage cover the pump (set) or the packaged pump (set) and accessories with waterproof material.

- Store the pump set in dry, vibration-free conditions and in its original packaging.
- Fill some antifreeze (e.g. ethylene glycol) into the pump to protect it from frost/freezing.
- Manually rotate the shaft once every three months as well as shortly before start-up.
- Spray the inside of the mechanical seal chamber with a preservative to prevent seizure of the mechanical seal.

Table 4: Ambient conditions for storage

Ambient condition	Value
Relative humidity	5 % to 80 % ²⁾ (non-condensing)
Ambient temperature	-10 °C to +40 °C ³⁾

3.4 Disposal

	! WARNING
	<p>Fluids handled, consumables and supplies which are hot and/or pose a health hazard Hazard to persons and the environment!</p> <ul style="list-style-type: none"> ▷ Collect and properly dispose of flushing fluid and any fluid residues. ▷ Wear safety clothing and a protective mask if required. ▷ Observe all legal regulations on the disposal of fluids posing a health hazard.

1. Dismantle the pump (set).
Collect greases and other lubricants during dismantling.
2. Separate and sort the pump materials, e.g. by:
 - Metals
 - Plastics
 - Electronic waste
 - Greases and other lubricants
3. Dispose of materials in accordance with local regulations or in another controlled manner.

1798.82/13-EN

² At +20 °C

³ Optional: -10 °C to +55 °C

3.5 Return to supplier

1. Drain the pump as per operating instructions. (⇒ Section 7.3, Page 43)
2. Flush and clean the pump, particularly if it has been used for handling noxious, explosive, hot or other hazardous fluids.
3. If the pump has handled fluids whose residues could lead to corrosion damage in the presence of atmospheric humidity or could ignite upon contact with oxygen, the pump must also be neutralised, and anhydrous inert gas must be blown through the pump to ensure drying.
4. Always complete and enclose a certificate of decontamination when returning the pump.
Indicate any safety measures and decontamination measures taken.
(⇒ Section 11, Page 73)



NOTE

If required, a blank certificate of decontamination can be downloaded from the following web site: www.ksb.com/certificate_of_decontamination

4 Description of the Pump (Set)

4.1 General description

- High-pressure in-line pump

Pump for handling clean or slightly aggressive aqueous fluids.

4.2 Product information

4.2.1 Product information as per Regulation No. 1907/2006 (REACH)

For information as per European chemicals regulation (EC) No. 1907/2006 (REACH) see <https://www.ksb.com/en-global/company/corporate-responsibility/reach>.

4.2.2 Product Information as per Regulation No. 547/2012 (for water pumps with a maximum shaft power of 150 kW) implementing "Ecodesign" Directive 2009/125/EC

- Minimum efficiency index: see name plate, key to name plate (⇒ Section 4.4, Page 20)
- The benchmark for the most efficient water pumps is $MEI \geq 0.70$.
- Year of construction: see name plate, key to name plate (⇒ Section 4.4, Page 20)
- Manufacturer's name or trade mark, commercial registration number and place of manufacture: see data sheet or order documentation
- Product's type and size identifier: see name plate, key to name plate (⇒ Section 4.4, Page 20)
- Hydraulic pump efficiency (%) with trimmed impeller: see data sheet
- Pump performance curves, including efficiency characteristics: see documented characteristic curve
- The efficiency of a pump with a trimmed impeller is usually lower than that of a pump with full impeller diameter. Trimming of the impeller will adapt the pump to a fixed duty point, leading to reduced energy consumption. The minimum efficiency index (MEI) is based on the full impeller diameter.
- Operation of this water pump with variable duty points may be more efficient and economic when controlled, for example, by the use of a variable speed drive that matches the pump duty to the system.
- Information on dismantling, recycling and disposal after decommissioning: (⇒ Section 3.4, Page 13)
- Information on benchmark efficiency or benchmark efficiency graph for $MEI = 0.70$ (0.40) for the pump based on the model shown in the Figure are available at: <http://www.europump.org/efficiencycharts>

4.3 Designation

Table 5: Designation example

Position																															
1	2	3	4	5	6	7	8	9	10	11	12	13	14	15	16	17	18	19	20	21	22	23	24	25	26	27	28	29	30	31	32
M	o	v	i	t	e	c	V	-	F	0	0	6	/	0	6	1	B	3	D	1	3	E	S	1	1	2	B	7	U	A	X
See name plate and data sheet																		See data sheet													

Table 6: Designation key

Position	Code	Description
1-7	Type series	
	Movitec	
8-9	Design	
	LH	Stainless steel 1.4404
	V	Stainless steel 1.4301
	VC	Stainless steel / grey cast iron 1.4301 / EN-GJL-250
	VM	Stainless steel 1.4301
	VS	Stainless steel 1.4404
10	Type of connection	
	⁴⁾	Oval flange
	⁵⁾	External thread
	F	Round flange
	I	Internal thread
	T	Tri-clamp fitting
	V	Victaulic coupling
11-13	Size	
	002	2

	125	125
15-16	Number of stages	
	01	1

	30	30
17	Number of stages with special impeller	
	-	No stage with a special impeller
	1	1 stage with a special impeller
	2	2 stages with a special impeller
	L	1 stage with a special impeller for lower NPSH values
	V	2 stages, 1 special impeller and 1 special impeller for lower NPSH values
	W	3 stages, 2 special impellers and 1 special impeller for lower NPSH values
18	Product generation	
	A	Movitec until 2009
	B	Movitec since 2010
	C	Movitec since 2021
19	Connection standard	
	0	Victaulic coupling No standard
	1	Round flange EN 1092

⁴ Blank

⁵ Pumps with external thread are supplied with an integrated swing check valve as standard.

Position	Code	Description
19	2	Round flange ASME B16.1
	3	Round flange JIS B2238
	4	Oval flange EN ISO 228-1
	5	Oval flange ASME B16.5
	6	Tri-clamp fitting DIN 32676
	7	External thread EN ISO 228-1
	8	Oval flange ISO 7/1
	9	Round flange ASME B16.5
20	Material variant	
	D	1.4308 - EN-GJS-400-15 - EN-GJL-250
	E	1.4308 - EN-GJS-400-15 - 1.4308
	F	1.4308 - 1.4308 - EN-GJL-250
	G	1.4308 - 1.4308 - EN-GJS-400-15
	H	1.4308 - 1.4308 - 1.4308
	K	1.4308 - 1.4408 - EN-GJS-400-15
	L	1.4308 - 1.4408 - EN-GJL-250
	M	1.4308 - 1.4408 - 1.4308
	N	1.4308 - EN-GJS-400-15 - EN-GJL-250
	O	1.4408 - EN-GJS-400-15 - 1.4308
	P	1.4408 - 1.4308 - EN-GJL-250
	Q	1.4408 - 1.4308 - 1.4308
	R	1.4408 - 1.4408 - EN-GJL-250
	S	1.4408 - 1.4408 - EN-GJS-400-15
	T	1.4408 - 1.4408 - 1.4308
	U	EN-GJL-250 - EN-GJL-250 - EN-GJL-250
	V	EN-GJS-400-15 - EN-GJS-400-15 - EN-GJS-400-15
	W	EN-GJS-400-15 - 1.4308 - EN-GJS-400-15
	X	1.4308 - EN-GJS-400-15 - EN-GJS-400-15
Y	1.4408 - EN-GJS-400-15 - EN-GJS-400-15	
Z	1.4408 - 1.4308 - EN-GJS-400-15	
21-22	Seal code	
	11	BQ1EGG
	12	BQ1VGG
	13	Q1BEGG
	14	Q1BVGG
	15	U3U3X4GG
	16	U3U3VGG
	17	U3BVGG ⁶⁾
	18	U3BEGG
	19	U3BEGG ⁶⁾
	20	Q1AEGG
	21	Q1AVGG
	22	Q1AX4GG
	23	Q1BEGG
	24	Q1Q1VGG
	28	Q1Q1X4GG
29	Q1Q1EGG	

1798.82/13-EN

⁶ For Movitec LHS only

Position	Code	Description
21-22	30	Q1Q1VGG
	33	Q1BEGG
	34	Q1BEFF
	35	eCarb-B eSiC-Q7EGG
	36	eCarb-B eSiC-Q7VGG
	37	U3AVGG
	38	U3U3VGG
	39	eCarb-B eSiC-Q7EGG
	40	Q1Q1EGG
	41	Q1AEGG
	42	Q1Q1VGG
	43	Q1AVGG
	23	Mechanical seal design
F		Fixed mechanical seal
E		Easy Access mechanical seal
C		Cartridge seal
24	Drive	
	0	Without motor
	2	With PumpDrive 2
	A	Version for potentially explosive atmospheres, IEC
	E	With PumpDrive 2 Eco
	N	Standard NEMA
	P	With PumpDrive
	S	Standard IEC
25-27	Motor size	
	056	NEMA 56C
	071	IEC 071
	080	IEC 080
	090	IEC 090
	100	IEC 100
	112	IEC 112
	132	IEC 132
	143	NEMA 143TC
	145	NEMA 145TC
	160	IEC 160
	180	IEC 180
	182	NEMA 182TC
	184	NEMA 184TC
	200	IEC 200
	215	NEMA 215TC
	225	IEC 225
	256	NEMA 256TC
	284	NEMA 284TC
	286	NEMA 286TC
324	NEMA 324TC	
326	NEMA 326TC	
364	NEMA 364TC	
28	Pressure class	
	A	PN16 / PN25

Position	Code	Description
28	B	PN25
	C	PN25 / PN40
	D	PN40
29	Frequency, number of motor poles	
	5	50 Hz, 2-pole
	6	60 Hz, 2-pole
	7	50 Hz, 4-pole
	8	60 Hz, 4-pole
30	Motor specification	
	F	EXM IEC - TBH
	G	EXM NEMA
	K	EXM IEC - Movitec
	M	230 V, single-phase AC motor
	O	0.37/0.55 kW, without IE classification
	U	230 / 400 V - IE3
	V	400 / 690 V - IE3
	W	230 / 400 V - IE4/IE5 (KSB SuPremE)
	X	400 / 690 V - IE4/IE5 (KSB SuPremE)
31	PumpMeter	
	A	With PumpMeter
	W	Without PumpMeter
32	Design	
	_4)	Standard
	X	Non-standard (BT3D, BT3)

4.4 Name plate

	NOTE
<p>If pumps with VdS certification are supplied, the details on the Movitec – VdS design name plate must be observed.</p>	

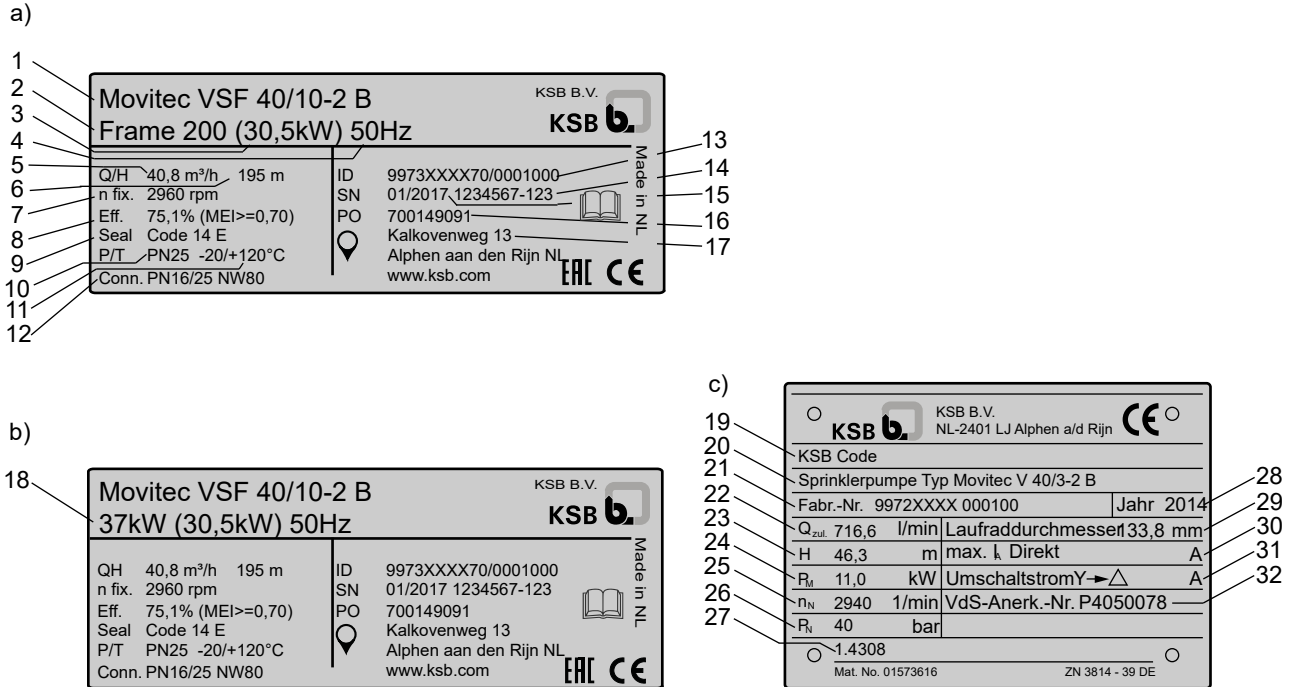

Fig. 2: Name plate (example) a) Pump without motor b) Pump with motor c) VdS design

1	Designation	2	Frame size
3	Power required at rated speed	4	Rated frequency
5	Flow rate ⁷⁾ at rated speed	6	Head ⁷⁾ at rated speed
7	Rated speed	8	Hydraulic efficiency ⁷⁾
9	Mechanical seal (code, design)	10	Maximum pressure at specified temperature
11	Maximum temperature at specified pressure	12	Pressure class
13	KSB order number	14	Serial number
15	Week of production / year of production	16	KSB purchase order number
17	Manufacturer's address	18	Rated motor power
19	KSB code	20	Type series, design, size, number of stages, number of reduced stages, and generation
21	KSB order number and order item number	22	VdS-approved flow rate at rated speed
23	VdS-approved head at rated speed	24	Required motor rating at 15 m NPSH at rated speed
25	Rated speed	26	Permissible nominal pressure
27	Pump casing material	28	Year of construction
29	Impeller diameter [mm]	30	Maximum starting current (only relevant for submersible pumps)
31	Switching current (only relevant for submersible pumps)	32	VdS approval number

⁷⁾ At best efficiency point (QBEP)

4.5 Design details

Design

- High-pressure in-line pump
- Maximum pressure class PN 40
- Centrifugal pump
- Single-stage or multistage

Installation

- Horizontal installation / vertical installation

Drive

- Surface-cooled KSB squirrel-cage motor
- 3~230/400 V up to 2.2 kW
- 3~400/690 V from 3.0 kW
- Thermal class F to IEC 34-1
- Efficiency class IE3 to IEC 60034-30 (for three-phase motors ≥ 0.75 kW)
- Enclosure IP55
- Frequency 50 Hz

Motor ≥ 3 kW:

- PTC thermistor

Automation

Automation options:

- PumpDrive
- PumpMeter

Shaft seal

- Uncooled maintenance-free mechanical seal
- To EN 12756
- Fixed mechanical seal
 - Mechanical seal in standard design
 - Unbalanced bellows-type seal
 - ≤ 25 bar
 - Available up to size 15
- Easy Access mechanical seal
 - Easy to replace
 - Unbalanced bellows-type seal
 - ≤ 25 bar
 - Drive lantern need not be removed to replace the seal.
 - Motor rating 5.5 kW and above: Motor need not be removed.
 - Available up to size 90⁸⁾
- Cartridge seal
 - Unbalanced bellows-type design (PN 25) or special balanced design (PN 40)
 - Drive lantern need not be removed to replace the seal.
 - Motor rating 5.5 kW and above: Motor need not be removed.
 - Optionally available for all sizes except Movitec LHS
 - Available for all sizes

⁸ With the exception of variant LHS

Bearings

- Product-lubricated stage bearing (tungsten carbide / aluminium oxide)

4.6 Configuration and function

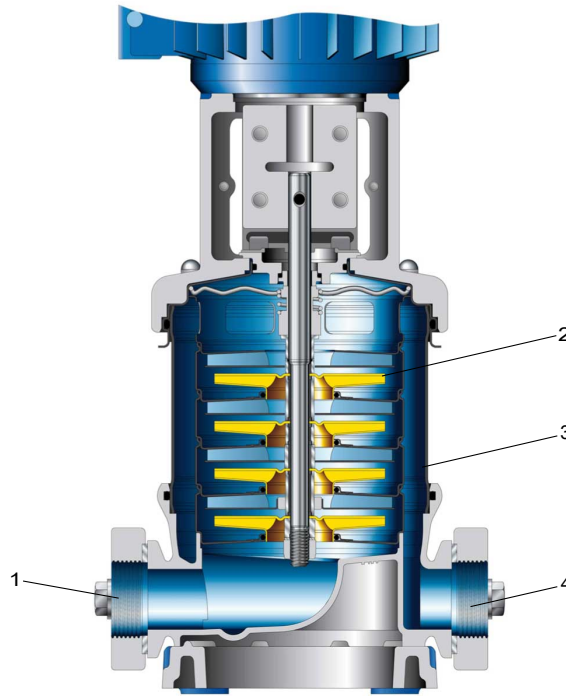

Fig. 3: Sectional drawing

1	Suction nozzle	3	Pump shroud
2	Impeller	4	Discharge nozzle

Design The pump is designed with a radial fluid inlet (suction nozzle) and a radial outlet (discharge nozzle) arranged on the same axis. The hydraulic system is rigidly connected to the motor by a shaft coupling.

Function During pump operation, a lower pressure forms at the impeller inlet. This lower pressure makes the fluid enter the pump via the suction nozzle (1). Each stage consists of one impeller (2) and one diffuser. The flow through a stage equals the flow rate of the pump. The stage diameter is related to the centrifugal forces and the stage pressure. The more stages, the higher the pressure. The fluid is guided outwards to the area between the pump stages and the pump shroud (3), from where it leaves the pump via the discharge nozzle (4).

Sealing The pump is sealed by a standardised mechanical seal.

4.7 Noise characteristics

The noise characteristics given refer to the motor. See motor literature supplied.

4.8 Scope of supply

Depending on the model, the following items are included in the scope of supply:







- Pump
- Electric motor

4.9 Dimensions and weights

For dimensions and weights refer to the general arrangement drawing/outline drawing or data sheet of the pump set.



5 Installation at Site

5.1 Safety regulations

	 DANGER
	<p>Installation in potentially explosive atmospheres Explosion hazard!</p> <ul style="list-style-type: none"> ▸ Never install the pump in potentially explosive atmospheres. ▸ Observe the information given in the data sheet and on the name plates of the pump system.
	 WARNING
	<p>Top-heavy product Damage to the pump set due to tipping over! Danger to life resulting from pump set tipping over!</p> <ul style="list-style-type: none"> ▸ Special caution must be taken when handling pump sets with frequency inverters. ▸ Always attach and fasten the pump set properly before removing any transport equipment or lifting equipment.
	 WARNING
	<p>Pump with long-term preservation: Harmful preservatives in drinking water systems Danger of poisoning!</p> <ul style="list-style-type: none"> ▸ Prior to commissioning / start-up, flush the system and pump set. ▸ If necessary, dismantle the pump and thoroughly remove the preservative from all wetted components. ▸ Observe the data given in the order confirmation.

5.2 Checks to be carried out prior to installation

Place of installation

	 WARNING
	<p>Installation on a mounting surface which is unsecured and cannot support the load Personal injury and damage to property!</p> <ul style="list-style-type: none"> ▸ Use a concrete of compressive strength class C12/15 which meets the requirements of exposure class XC1 to EN 206. ▸ The mounting surface must be set, even, and level. ▸ Observe the weights indicated.

1. Check the structural requirements.
All structural work required must have been prepared in accordance with the dimensions stated in the outline drawing/general arrangement drawing.

5.3 Installing the pump set

	CAUTION
	<p>Ingress of leakage into the motor Damage to the pump!</p> <ul style="list-style-type: none"> ▸ Never install the pump set with the "motor below".

1. Install and fasten the pump set on a sturdy and level foundation in a dry and frost-proof room.
2. Make sure that sufficient air can reach the fan opening of the motor. (The clearance above the fan opening must measure at least 1/4 of the diameter of the fan cover air intake.)
3. Place a spirit level on the discharge nozzle to align the pump set.
4. Make sure that no clogging can occur in the suction nozzle of the pump.

5.4 Piping

5.4.1 Connecting the piping

	⚠ DANGER
	<p>Impermissible loads acting on the pump nozzles Danger to life from leakage of hot, toxic, corrosive or flammable fluids!</p> <ul style="list-style-type: none"> ▸ Do not use the pump as an anchorage point for the piping. ▸ Anchor the pipes in close proximity to the pump and connect them properly without transmitting any stresses or strains. ▸ Take appropriate measures to compensate for thermal expansion of the piping.

	CAUTION
	<p>Incorrect earthing during welding work at the piping Destruction of rolling element bearings (pitting effect)!</p> <ul style="list-style-type: none"> ▸ Never earth the electric welding equipment on the pump or baseplate. ▸ Prevent current flowing through the rolling element bearings.

	NOTE
	<p>Installing check and shut-off elements in the system is recommended, depending on the type of plant and pump. However, such elements must not obstruct proper drainage or hinder disassembly of the pump.</p>

	NOTE
	VdS-certified pumps must be connected in compliance with current information from VdS CEA 4001.

- ✓ Suction lift lines have been laid with a rising slope, suction head lines with a downward slope towards the pump.
- ✓ A flow stabilisation section having a length equivalent to at least twice the diameter of the suction flange has been provided upstream of the suction flange.
- ✓ The nominal diameters of the pipelines are equal to or greater than the nominal diameters of the pump nozzles.
As far as the nominal diameters in the suction and discharge line, and installation of check valves and shut-off elements in a fire protection system are concerned, observe the sizing specifications in the relevant directives.
- ✓ Adapters to larger nominal diameters are designed with a diffuser angle of approx. 8° to avoid excessive pressure losses.
- ✓ The pipelines have been anchored in close proximity to the pump and connected without transmitting any stresses or strains.
 1. Thoroughly clean, flush and blow through all vessels, pipelines and connections (especially of new installations).
 2. Before installing the pump in the piping, remove the flange covers on the suction and discharge nozzles of the pump.

	CAUTION
	<p>Welding beads, scale and other impurities in the piping Damage to the pump!</p> <ul style="list-style-type: none"> ▷ Remove any impurities from the piping. ▷ If necessary, install a filter.

3. If required, install a filter in the piping (see drawing: Filter in the piping).

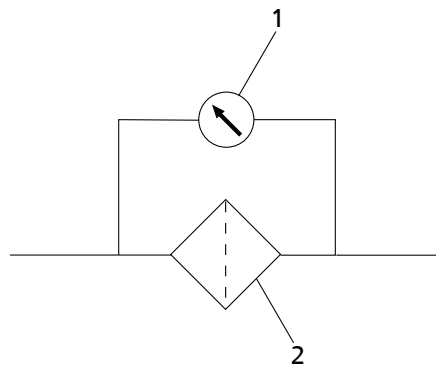



Fig. 4: Filter in the piping

1	Differential pressure gauge	2	Filter
---	-----------------------------	---	--------

	NOTE
	<p>Use a filter with laid-in wire mesh (mesh width 0.5 mm, wire diameter 0.25 mm) of corrosion-resistant material. Use a filter with a filter area three times the cross-section of the piping. Conical filters have proved suitable.</p>

4. Connect the pump nozzles to the piping.

	CAUTION
	<p>Aggressive flushing liquid and pickling agent Damage to the pump!</p> <p>▷ Match the cleaning operation mode and duration of flushing and pickling to the casing materials and seal materials used.</p>

5.4.2 Permissible forces and moments at the pump nozzles

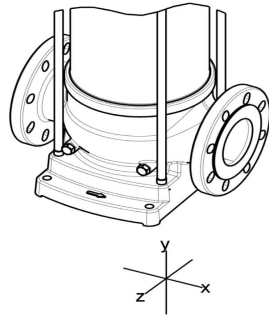

Fig. 5: Forces and moments at the pump nozzles

Direction of forces	
F_x	Horizontal, parallel to the pump axis
F_y	Vertical to the pump axis
F_z	Horizontal, at a right angle to the pump axis
Direction of moments	
M_x	Around the horizontal axis, parallel to the pump axis
M_y	Around the vertical nozzle axis
M_z	Around the horizontal axis, at a right angle to the pump axis

Forces and moments at the pump nozzles

Table 7: Forces and moments at the pump nozzles of Movitec V(S)F

Movitec	DN	F_x	F_y	F_z	ΣF	M_x	M_y	M_z	ΣM
	[mm]	[N]	[N]	[N]	[N]	[Nm]	[Nm]	[Nm]	[Nm]
2B	25	3300	-2400	1700	4400	280	95	-210	400
4B	25	3300	-2400	1700	4400	280	95	-210	400
6B	32	3300	-2400	1700	4400	280	95	-210	400
10B	40	4000	-3100	3100	5900	440	180	-200	500
15B	50	4000	-3100	3100	5900	440	180	-200	500
15C	50	4000	-3100	3100	5900	440	180	-200	500
25B	65	3200	-3500	3500	5890	1000	230	-400	1100
40B PN 16/25	80	4000	-1800	2000	4820	400	200	-300	540
40B PN 40	80	3700	-3300	3700	6190	975	240	-450	1100
60B PN 16/25	100	4000	-1800	2000	4820	400	200	-300	540
60B PN 40	100	3700	-3300	3700	6190	975	240	-450	1100
90B	100	3500	-2500	1000	4420	750	500	-625	1100
125B PN16	125	4400	-1700	1700	5010	600	425	-425	850
125B PN25	125	7000	-2620	2620	7920	1000	655	-655	1360

Table 8: Forces and moments at the pump nozzles of Movitec VCF

Size	DN	F _x	F _y	F _z	Σ F	M _x	M _y	M _z	Σ M
	[mm]	[N]	[N]	[N]	[N]	[Nm]	[Nm]	[Nm]	[Nm]
2B	25	9400	-3200	3200	10430	600	300	360	760
4B	25	9400	-3200	3200	10430	600	300	360	760
6B	32	9400	-3200	3200	10430	600	300	360	760
10B	40	8000	-2000	3200	8850	460	460	-500	820
15B	50	8000	-2000	3200	8850	460	460	-500	820
15C	50	8000	-2000	3200	8850	460	460	-500	820
25B	65	5000	-2000	2500	5940	1000	300	-300	1090
40B	80	6000	-3000	3000	7350	1800	1000	-1000	2290
60B	100	6000	-3000	3000	7350	1800	1000	-1000	2290
90B	100	6200	-4100	4100	8490	2000	1200	-1200	2620
125B PN16	125	4400	-1700	1700	5010	600	425	-425	850
125B PN25	125	7000	-2620	2620	7920	1000	650	-650	1360

Table 9: Forces and moments at the pump nozzles of Movitec LHS

Size	DN	F _x	F _y	F _z	Σ F	M _x	M _y	M _z	Σ M
	[mm]	[N]	[N]	[N]	[N]	[Nm]	[Nm]	[Nm]	[Nm]
LHS 6	32	8000	-2000	3200	8800	460	460	-500	800

5.5 Fitting a bypass

	NOTE
	<p>If the pump is operated against a closed valve, installing a bypass is recommended. The bypass capacity must correspond to at least the minimum permissible volume flow rate.</p>





5.6 Electrical connection

	⚠ DANGER
	<p>Incorrect connection Explosion hazard!</p> <ul style="list-style-type: none"> ▸ The connection point of the cable ends must be located outside hazardous areas or in an area approved for electrical equipment.

	⚠ DANGER
	<p>Operating an incompletely connected pump set Damage to the pump set!</p> <ul style="list-style-type: none"> ▸ Never start up a pump set with incompletely connected cables or non-operational monitoring devices.

	⚠ DANGER
	<p>Connection of damaged electric cables Danger of death from electric shock!</p> <ul style="list-style-type: none"> ▸ Check the electric cables for any damage before connecting them. ▸ Never connect damaged electric cables. ▸ Replace damaged electric cables.

1798.82/13-EN

	<p>⚠ DANGER</p> <p>Electrical connection work by unqualified personnel Danger of death from electric shock!</p> <ul style="list-style-type: none"> ▷ Always have the electrical connections installed by a trained electrician. ▷ Observe regulations IEC 60364 and, for explosion-proof versions, EN 60079 .
	<p>⚠ WARNING</p> <p>Incorrect connection to the mains Damage to the power supply network, short circuit!</p> <ul style="list-style-type: none"> ▷ Observe the technical specifications of the local energy supply companies.
	<p>CAUTION</p> <p>Improper routing of electric cables Damage to the electric cables!</p> <ul style="list-style-type: none"> ▷ Never move the electric cables at temperatures below -25 °C. ▷ Never kink or crush the electric cables. ▷ Never lift the pump set by the electric cables. ▷ Adjust the length of the electric cables to the site requirements.
	<p>CAUTION</p> <p>Pump (set) overload Damage to the machinery!</p> <ul style="list-style-type: none"> ▷ Protect the motor by a thermal time-lag overload protection device in accordance with IEC 947 and local regulations. (If the pump is used in a fire protection system as the main fire-fighting pump, the pump must not be tripped automatically by motor protection devices!) ▷ Make sure that the motor's specifications match those of the power supply it will be connected to.
	<p>NOTE</p> <p>Sprinkler pumps with VdS certification must not be able to be tripped automatically by measures of any kind.</p>

For electrical connection observe the wiring diagrams in the Annex and the information for planning the control system.

If a motor of a different make is used, observe the relevant operating instructions.

The pump set is supplied with power cables as standard. Always use all cables provided and connect all marked cores of the control cable.

The permissible rated current of the motor supplied is shown on the motor name plate.

It describes the permissible operating range of the motor and can be used for setting the overload protection device. If the actual power input is measured during operation, the motor protection switch can be pre-set to a lower value to protect the pump set.

This current value can also be used to select appropriate electrical equipment such as frequency inverter, master switch, conductor diameter, etc.

5.6.1 Overload protection

Standard motors ≥ 3 kW are equipped with three PTC thermistors.

Table 10: Technical data of the PTC thermistors

Size	Value
t_n [°C]	140
$R_{20^\circ\text{C}}$ [Ω]	~ 20
$R_{t_n-20^\circ\text{C}}$ [Ω]	~ 250
$R_{t_n-5^\circ\text{C}}$ [Ω]	< 550
$R_{t_n+5^\circ\text{C}}$ [Ω]	> 1330
$R_{t_n+15^\circ\text{C}}$ [Ω]	> 4000
U_n [V DC]	$2.5 < U < 30$

	NOTE
	Sprinkler pumps with VdS certification must not be able to be tripped automatically by measures of any kind.

1. Protect the pump set against overloading by a thermal time-lag overload protection device in accordance with IEC 947 and local regulations.
2. Connect the PTC to a thermistor relay.

5.6.2 Earthing

	⚠ DANGER
	<p>Electrostatic charging Explosion hazard! Damage to the pump set!</p> <ul style="list-style-type: none"> ▸ Connect the PE conductor to the earthing terminal provided. ▸ Provide for potential equalisation between the pump set and the foundation.

5.7 Checking the direction of rotation

	⚠ DANGER
	<p>Temperature increase resulting from contact between rotating and stationary components Damage to the pump set!</p> <ul style="list-style-type: none"> ▸ Never check the direction of rotation by starting up the unfilled pump set. ▸ Separate the pump from the motor to check the direction of rotation.

	⚠ WARNING
	<p>Hands inside the pump casing Risk of injuries, damage to the pump!</p> <ul style="list-style-type: none"> ▸ Always disconnect the pump set from the power supply and secure it against unintentional start-up before inserting your hands or other objects into the pump.

	CAUTION
	<p>Drive and pump running in the wrong direction of rotation Damage to the pump!</p> <ul style="list-style-type: none"> ▸ Refer to the arrow indicating the direction of rotation on the pump. ▸ Check the direction of rotation. If required, check the electrical connection and correct the direction of rotation.

The correct direction of rotation of the motor and pump is clockwise (seen from the drive end).

1. Start the motor and stop it again immediately to determine the motor's direction of rotation.
2. Check the direction of rotation.
The motor's direction of rotation must match the arrow indicating the direction of rotation on the pump.
3. If the motor is running in the wrong direction of rotation, check the electrical connection of the motor and the control system, if applicable.

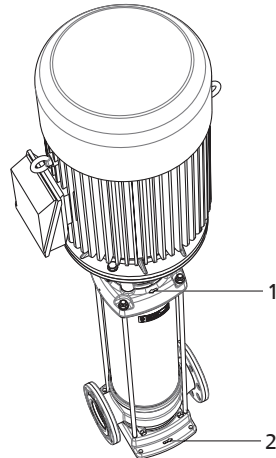

Fig. 6: Direction of fluid flow and arrow indicating the direction of rotation

1	Direction of rotation of the motor	2	Direction of fluid flow
---	------------------------------------	---	-------------------------

6 Commissioning/Start-up/Shutdown

6.1 Commissioning/Start-up

6.1.1 Prerequisites for commissioning/start-up



Before commissioning/starting up the pump set, make sure that the following conditions are met:

- The pump set has been installed correctly.
- The pump set has been flushed and disinfected in accordance with local requirements.
- The pump set has been properly connected to the power supply and is equipped with all protection devices.
- The pump has been filled with the fluid to be handled. The pump has been vented.
- The direction of rotation has been checked.
- All auxiliary connections required are connected and operational.
- Pump shaft and motor shaft are running smoothly and without any excessive noise.
- After prolonged shutdown of the pump (set), the activities required for returning the equipment to service have been carried out. (⇒ Section 6.4, Page 39)
- The coupling guard (681) and/or the ATEX-compliant external protection device (680), if any, have been mounted.
- Take care to secure the pump against external damage.

The following must be ensured for a pump with a thrust bearing housing:

- The axial clearance between the thrust bearing housing and the motor shaft is set correctly.

6.1.2 Priming and venting the pump

	<p style="background-color: #e67e22; color: white; padding: 5px;">⚠ DANGER</p> <p>Formation of a potentially explosive atmosphere inside the pump Explosion hazard!</p> <ul style="list-style-type: none"> ▸ Before starting up the pump set, vent the pump and suction line and prime both with the fluid to be handled.
	<p style="background-color: #f1c40f; padding: 5px;">CAUTION</p> <p>Increased wear due to dry running Damage to the pump set!</p> <ul style="list-style-type: none"> ▸ Never operate the pump set without liquid fill. ▸ Never close the shut-off element in the suction line and/or supply line during pump operation.

Priming in an open or closed circuit with sufficient supply pressure

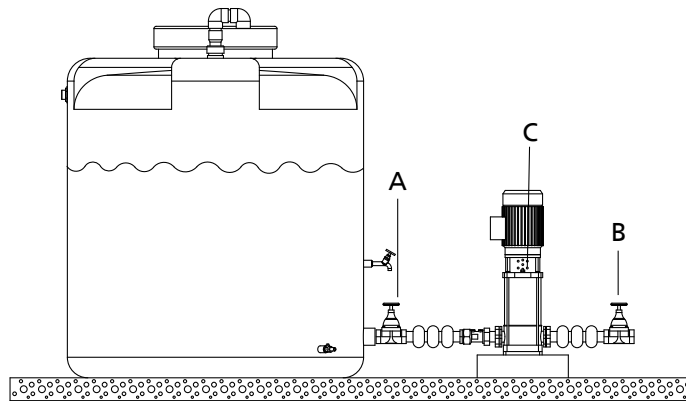

Fig. 7: Pump with open or closed circuit

A	Shut-off element in the suction line	B	Shut-off element in the discharge line
C	Filler opening		

1. Close the shut-off element in suction line A and the shut-off element in discharge line B.
2. Open filler opening C.
3. Open the shut-off element in suction line A gradually until fluid escapes from filler opening C.
4. Close filler opening C.
5. Fully open the shut-off element in suction line A.
6. Fully open the shut-off element in discharge line B.

Priming in open circuit with fluid level below the pump

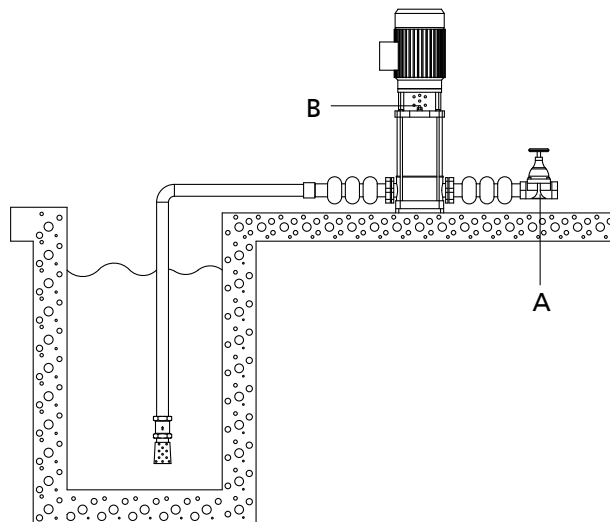

Fig. 8: Pump with open circuit and fluid level below the pump

A	Shut-off element in the discharge line	B	Filler opening
---	--	---	----------------

1. Remove the plug of filler opening B from the upper support bracket.
2. Close the shut-off element in discharge line A.
3. Fill fluid into the pump casing through filler opening B until the fluid reaches the maximum fill level.

4. Close filler opening B.
5. Fully open the shut-off element in discharge line A.

Venting

The pump can be vented via the corresponding connections when it is not in operation.

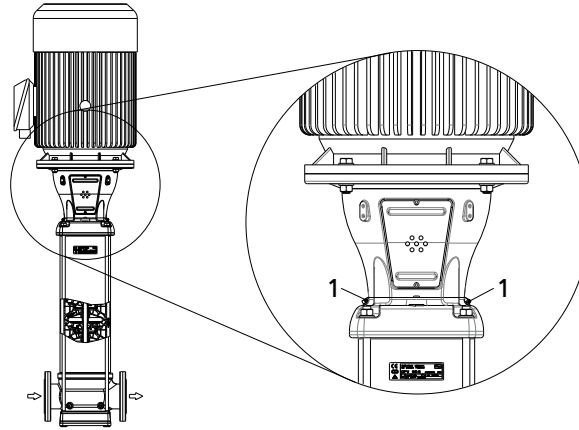

Fig. 9: Vent connections

1	Vent connections
---	------------------

6.1.3 Checking the shaft seal

Mechanical seal The mechanical seal only leaks slightly or invisibly (as vapour) during operation. Mechanical seals are maintenance-free.

Shaft seal failure can lead to increased leakage.

6.2 Operating limits

	<p>⚠ DANGER</p>
	<p>Non-compliance with operating limits Damage to the pump set!</p> <ul style="list-style-type: none"> ▷ Comply with the operating data indicated in the data sheet. ▷ Avoid operation against a closed shut-off element. ▷ Never operate the pump set outside the limits specified below.
	<p>⚠ DANGER</p>
	<p>Non-compliance with operating limits for the fluid handled Explosion hazard!</p> <ul style="list-style-type: none"> ▷ Never use the pump to handle different fluids which might react chemically with each other. ▷ Never use the pump to handle a flammable fluid with a fluid temperature above the ignition temperature.

1798.82/13-EN

	CAUTION
	<p>Excessive temperature difference between the fluid handled and the pump Damage to the machinery!</p> <ul style="list-style-type: none"> ▷ The temperature difference between the fluid handled and the pump must never exceed 60 °C. ▷ If the temperature difference between the pump and the fluid handled exceeds 30 °C, prime/heat up the pump slowly to avoid any risk of thermal shock.

The operating range depends on the application as well as on the combination of pressure and temperature.

Table 11: Specified operating range

Characteristic	Operating range
Ambient temperature [°C] ⁹⁾	-20 to 40
Minimum inlet pressure	NPSH _{req} + 1 m
Viscosity [cSt] ¹⁰⁾	1 - 100
Density [kg/m ³] ¹⁰⁾	1000 - 2500
Frequency [Hz] ¹¹⁾	30 - 60
Maximum number of starts per hour ¹²⁾	See motor data sheet
Permissible particle size [mm]	0,005 - 1
Cooling ¹³⁾	Forced cooling

6.2.1 Pressure limits and temperature limits

6.2.1.1 Movitec A, B, C

Movitec A

Table 12: Pressure limits and temperature limits

Movitec	p	T
	[bar]	[°C]
LHS 6	40	120

Movitec B, C

The pump's pressure limits and temperature limits are indicated on the name plate. (⇒ Section 4.4, Page 20)

⁹⁾ If the ambient temperature exceeds the permissible maximum or if the motor is located more than 1000 metres above sea level, the motor cooling is less effective and the motor might have to be de-rated. The motor load depends on the installation altitude above sea level or on the ambient temperature. For detailed recommendations contact your sales house.

¹⁰⁾ Fluctuations could require de-rating of the motor. For more detailed recommendations contact your sales house.

¹¹⁾ Pumps which are selected for 50 Hz must not be connected to a 60 Hz mains.

¹²⁾ Excessive starting/stopping, particularly in combination with high pressure differences (Δp) may reduce the service life of the product.

¹³⁾ The clearance above the fan openings of the motor must measure at least 1/4 of the diameter of the fan openings to allow the (cooling) air to circulate properly.

6.2.1.2 Shaft seal

Table 13: Available mechanical seals

Seal code	Type	Mechanical seal					T		Pressure [bar]	Certification
		Material		Design			Min.	Max.		
		Mechanical seal	Shaft seal ring	F	E	C	[°C]	[°C]		
11	M12G-G60	BQ1EGG	Ca/SiC/EPDM	X	X	X	-20	+100	10	-
12	M12G-G60	BQ1VGG	Ca/SiC/FPM	X	X	X	-20	+120	10	-
13	RMG12-G606	Q1BEGG	SiC/Ca/EPDM	X	X	X	-20	+100	25	WRAS
14	RMG12-G606	Q1BVGG	SiC/Ca/FPM	X	X	X	-20	+120	25	-
15	RMG12-G606	U3U3X4GG	TuC/TuC/HNBR	X	X	X	-20	+120 ¹⁴⁾	25	-
16	RMG12-G606	U3U3VGG	TuC/TuC/FPM	X	X	X	-20	+120 ¹⁴⁾	25	-
17	M37GN2/16-00-R	U3BVGG ¹⁵⁾	TuC/Ca/FPM ¹⁵⁾	X	-	-	-20	+120 ¹⁶⁾	40	-
18	RMG12-G606	U3BEGG	TuC/Ca/EPDM	X	X	X	-20	+120 ¹⁴⁾	25	-
19	M37GN2/16-00-R	U3BEGG ¹⁵⁾	TuC/Ca/EPDM ¹⁵⁾	X	-	-	-20	+120 ¹⁶⁾	40	-
20	H7N	Q1AEGG ¹⁷⁾	SiC/Ca/EPDM	-	-	X	-20	+120 ¹⁸⁾	40	-
21	H7N	Q1AVGG ¹⁷⁾	SiC/Ca/FPM	-	-	X	-20	+120 ¹⁸⁾	40	-
22	H7N	Q1AX4GG	SiC/Ca/HNBR	-	-	X	-20	+120 ¹⁸⁾	40	-
23	RMG12-G606	Q1BEGG	SiC/Ca/EPDM	X	X	X	-20	+100	25	-
24	MG12-G60	Q1Q1VGG	SiC1/SiC1/FPM	X	X	X	-20	+120	10	-
28	MG12-G60	Q1Q1X4GG	SiC1/SiC1/HNBR	X	X	X	-20	+120	10	-
29	MG12-G60	Q1Q1EGG	SiC1/SiC1/EPDM	X	X	X	-20	+100	10	-
35	RMG12-G6	eCarb-B eSiC-Q7EGG	eCa/eSiC/EPDM	-	-	X	-20	+120	25	WRAS
36	MG12-G6	eCarb-B eSiC-Q7VGG	eCa/eSiC/FPM	-	-	X	-20	+120	25	-
37	RMG12-G606	U3AVGG	TuC/Ca/FPM	-	-	X	-20	+120 ¹⁴⁾	25	-
40	4MC	Q1Q1EGG ¹⁹⁾	SiC SiC EPDM	-	-	X	-20	+120	40	-
41	4MC	Q1AEGG ¹⁹⁾	SiC Ca EPDM	-	-	X	-20	+120	40	-
42	4MC	Q1Q1VGG ¹⁹⁾	SiC SiC FPM	-	-	X	-20	+120	40	-
43	4MC	Q1AVGG ¹⁹⁾	SiC Ca FPM	-	-	X	-20	+120	40	-

¹⁴⁾ Temperatures up to +140 °C if the pressure does not exceed 16 bar

¹⁵⁾ For Movitec LHS6 only

¹⁶⁾ If the pressure does not exceed 25 bar. Temperatures up to +80 °C if the pressure does not exceed 40 bar

¹⁷⁾ Movitec 90B

¹⁸⁾ Temperatures up to +140 °C if the pressure does not exceed 25 bar

¹⁹⁾ Movitec 2B, 4B, 6B, 10B, 15B/C, 25B, 40B, 60B

Table 14: Key to mechanical seal materials

Description	Code to EN 12756	Seal face materials / secondary seals
Primary ring	B	Hard carbon, resin-impregnated
	U3	Tungsten carbide (CrNiMo binder)
	Q1	Silicon carbide, sintered without pressure
	eCarb-B	Carbon graphite, resin-impregnated
Mating ring	A	Carbon graphite, antimony-impregnated
	B	Hard carbon, resin-impregnated
	U3	Tungsten carbide (CrNiMo binder)
	Q1	Silicon carbide, sintered without pressure
	eSic-Q7	Silicon carbide
Elastomer	E	EPDM (ethylene propylene rubber)
	V	FPM (fluoroelastomer)
	X4	HNBR
Spring	G	CrNiMo steel
Other metal parts	G	CrNiMo steel

6.2.2 Rated current and maximum current

Movitec A

The maximum permissible rated current of the motor supplied is shown on the motor name plate as I_{max} .

This maximum current value describes the maximum permissible operating range of the motor and can be used for setting the overload protection device. The actual current input at 400 V is shown on the pump name plate as I_{nom} . It can be used to pre-set the motor protection switch in order to protect the pump set.

This current value can also be used to select appropriate electrical equipment such as frequency inverter, master switch, conductor diameter, etc.

Movitec B, C

The permissible rated current of the motor supplied is shown on the motor name plate.

It describes the permissible operating range of the motor and can be used for setting the overload protection device. If the actual power input is measured during operation, the motor protection switch can be pre-set to a lower value to protect the pump set.

This current value can also be used to select appropriate electrical equipment such as frequency inverter, master switch, conductor diameter, etc.

6.2.3 Fluid handled

6.2.3.1 Density of the fluid handled

The power input of the pump set will change in proportion to the density of the fluid handled.

	CAUTION
	<p>Impermissibly high density of the fluid handled Motor overload!</p> <ul style="list-style-type: none"> ▸ Observe the information about fluid density in the data sheet. ▸ Make sure the motor has sufficient power reserves.

6.2.3.2 Minimum flow rate and maximum permissible flow rate

	⚠ DANGER
	<p>Operating the pump set at low flow Temperature increase caused by insufficient flow! Explosion hazard!</p> <ul style="list-style-type: none"> ▸ Always operate the pump set at the permissible flow rates. ▸ If lower flow rates are to be expected, use a bypass.

	⚠ DANGER
	<p>Operating the pump set when the conductivity of the fluid handled is too low Build-up of static electricity in the pump! Explosion hazard!</p> <ul style="list-style-type: none"> ▸ Never handle fluids with a conductivity ≤ 50 pS/m

	CAUTION
	<p>Operation below the NPSH required</p> <p>Damage to hydraulic parts!</p> <p>Damage to the pump set!</p> <p>▷ Never operate the pump set at an inlet pressure lower than that indicated in the NPSH requirements.</p>

Bypass capacity Bypass capacity must match at least the minimum permissible volume flow of the pump set.

Table 15: Minimum flow rate and maximum flow rate Q at a fluid temperature $\leq +20\text{ }^{\circ}\text{C}$, depending on the speed

Movitec	Q							
	50 Hz				60 Hz			
	2 poles		4 poles		2 poles		4 poles	
	min.	max.	min.	max.	min.	max.	min.	max.
	[m ³ /h]	[m ³ /h]	[m ³ /h]	[m ³ /h]	[m ³ /h]	[m ³ /h]	[m ³ /h]	[m ³ /h]
2B	0,2	3,3	-	-	0,2	4,0	-	-
4B	0,4	6,5	-	-	0,5	7,8	-	-
6B	0,6	9,0	-	-	0,8	8,6	-	-
10B	1,1 ²⁰	13,2	0,5	6,6	1,3	15,8	0,6	7,9
15B	1,6 ²⁰	22,5	0,8	11,3	2,0	27,0	1,0	13,5
15C	1,9 ²⁰	22,5	0,9	11,3	2,3	27,0	1,1	13,5
25B	2,8	35,0	1,4	17,5	3,1	42,0	1,6	21,0
40B	4,0	54,0	2,0	27	5,1	65,0	-	-
60B	6,0	76,0	3,0	38	6,1	90,0	-	-
90B	8,5	110,0	4,3	53,9	10,2	132,0	5,0	65,1
125B	30,0	160,0	15,0	80,0	36,0	192,0	18,0	96,0
LHS 6	0,8	8,6	-	-	0,7	8,6	-	-

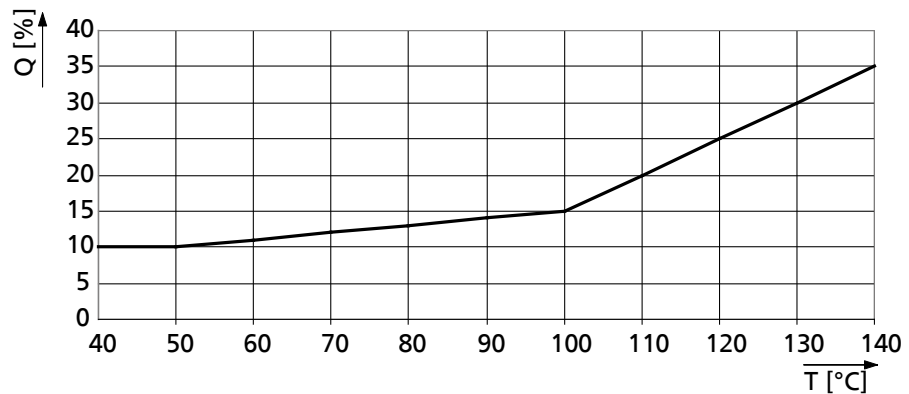

Fig. 10: Minimum flow rate required as a function of the fluid temperature, for fluid temperatures $> 20\text{ }^{\circ}\text{C}$

²⁰ For pumps with VdS certification the minimum flow rate Q_{\min} is 5 % of the approved rated flow.

6.2.3.3 Viscosity of the fluid handled

	CAUTION
	<p>The viscosity of the fluid handled is higher than that of water.</p> <p>Motor overload</p> <ul style="list-style-type: none"> ▷ Observe the type and viscosity limits for the fluid handled given in the data sheet. ▷ Ensure that the motor power reserve is sufficient.

6.3 Shutdown/storage/preservation

6.3.1 Measures to be taken for shutdown

The pump set remains installed

- ✓ Sufficient fluid is supplied for the functional check run of the pump.
 1. Start up the pump regularly once a month or once every three months for approximately five minutes during prolonged shutdown periods. This will prevent the formation of deposits within the pump and the pump intake area.

	CAUTION
	<p>Danger of freezing during prolonged pump shutdown periods</p> <p>Damage to the pump!</p> <ul style="list-style-type: none"> ▷ The temperature maintenance equipment must remain in operation also during pump shutdown periods.

The pump set is removed from the piping and stored

- ✓ The checks and maintenance operations have been performed.
 1. Spray-coat the inside wall of the pump casing with a preservative.
 2. Spray the preservative through the inlet and outlet nozzles of the fluid handled. It is advisable to close the fluid inlet and outlet nozzles afterwards (e.g. with plastic caps or similar).

Observe any additional instructions and information provided. (⇒ Section 3, Page 11)

6.4 Returning to service

For returning the equipment to service observe the sections on commissioning/start-up and the operating limits. (⇒ Section 6.1, Page 31)



In addition, carry out all servicing/maintenance operations before returning the pump (set) to service. (⇒ Section 7, Page 40)



	⚠ WARNING
	<p>Failure to re-install or re-activate protective devices</p> <p>Risk of injury from moving parts or escaping fluid!</p> <ul style="list-style-type: none"> ▷ As soon as the work is completed, properly re-install and re-activate any safety-relevant devices and protective devices.

	NOTE
	<p>If the equipment has been out of service for more than one year, replace all elastomer seals.</p>



7 Servicing/Maintenance



7.1 Safety regulations



	 DANGER
	<p>Sparks produced during servicing work Explosion hazard!</p> <ul style="list-style-type: none"> ▷ Observe the safety regulations in force at the place of installation! ▷ Never open an energised pump set. ▷ Always perform maintenance work on pump sets outside potentially explosive atmospheres only.

	 DANGER
	<p>Improperly serviced pump set Damage to the pump set!</p> <ul style="list-style-type: none"> ▷ Service the pump set regularly. ▷ Prepare a maintenance schedule with special emphasis on lubricants, power cable, bearing assembly and shaft seal.

The operator ensures that maintenance, inspection and installation are performed by authorised, qualified specialist personnel who are thoroughly familiar with the manual.

	 WARNING
	<p>Unintentional starting of the pump set Risk of injury by moving components and shock currents!</p> <ul style="list-style-type: none"> ▷ Ensure that the pump set cannot be started unintentionally. ▷ Always make sure the electrical connections are disconnected before carrying out work on the pump set.

	 WARNING
	<p>Fluids handled, consumables and supplies which are hot and/or pose a health hazard Risk of injury!</p> <ul style="list-style-type: none"> ▷ Observe all relevant laws. ▷ When draining the fluid take appropriate measures to protect persons and the environment. ▷ Decontaminate pumps which handle fluids posing a health hazard.

	 WARNING
	<p>Insufficient stability Risk of crushing hands and feet!</p> <ul style="list-style-type: none"> ▷ During assembly/dismantling, secure the pump (set)/pump parts to prevent tilting or tipping over.

A regular maintenance schedule will help avoid expensive repairs and contribute to trouble-free, reliable operation of the pump, pump set and pump parts with a minimum of servicing/maintenance expenditure and work.

	NOTE
	<p>All maintenance work, service work and installation work can be carried out by KSB Service or authorised workshops. For contact details refer to the enclosed "Addresses" booklet or visit "www.ksb.com/contact" on the Internet.</p>

Never use force when dismantling and reassembling the pump set.

7.2 Servicing/inspection

7.2.1 Supervision of operation

	DANGER
	<p>Formation of a potentially explosive atmosphere inside the pump Explosion hazard!</p> <ul style="list-style-type: none"> ▷ Before starting up the pump set, vent the pump and suction line and prime both with the fluid to be handled.

	DANGER
	<p>Incorrectly serviced shaft seal Fire hazard! Hot fluids escaping! Damage to the pump set!</p> <ul style="list-style-type: none"> ▷ Regularly service the shaft seal.

	DANGER
	<p>Excessive temperatures as a result of bearings running hot or defective bearing seals Fire hazard! Damage to the pump set!</p> <ul style="list-style-type: none"> ▷ Regularly check the condition of the lubricant. ▷ Regularly check the rolling element bearings for running noises.

	CAUTION
	<p>Increased wear due to dry running Damage to the pump set!</p> <ul style="list-style-type: none"> ▷ Never operate the pump set without liquid fill. ▷ Never close the shut-off element in the suction line and/or supply line during pump operation.

	CAUTION
	<p>Impermissibly high temperature of fluid handled Damage to the pump set!</p> <ul style="list-style-type: none"> ▷ Prolonged operation against a closed shut-off element is not permitted (heating up of the fluid). ▷ Observe the temperature limits in the data sheet and in the section on operating limits.

While the pump is in operation, observe and check the following:

- The pump must run quietly and free from vibrations at all times.
- Check the shaft seal.
Visual inspection while rotating the shaft once by hand.
- Check the static sealing elements for leakage.
No leakage from the sealing elements is allowed.
- Check the rolling element bearings for running noises.
Vibrations, noise and an increase in current input occurring during unchanged operating conditions indicate wear.
- Monitor the correct functioning of any auxiliary connections.

7.2.2 Lubrication and lubricant change

	DANGER
	<p>Excessive temperatures as a result of bearings running hot or defective bearing seals Fire hazard! Damage to the pump set!</p> <ul style="list-style-type: none"> ▷ Regularly check the condition of the lubricant. ▷ Regularly check the rolling element bearings for running noises.

7.2.2.1 Grease lubrication

The bearings are supplied packed with high-quality lithium-soap grease.

7.2.2.1.1 Intervals

Depending on the pump size and rotational speed, re-lubricate the rolling element bearings or replace the grease at regular intervals.

	NOTE
	<p>On some pump designs the rolling element bearings are lubricated for life. These pumps are not provided with a lubricating nipple on the bearing bracket.</p>

	NOTE
	<p>If re-lubrication intervals are short, we recommend that the grease be completely replaced once a year. Otherwise, the grease fill must be replaced completely every two years. To do so, remove the rolling element bearings, clean and pack with new grease.</p>

Motors and thrust bearing housings (if any) with lubricating nipple must be re-lubricated every 2000 hours.

If the pump is operated under extreme conditions, such as vibrations or high temperatures, the motors and (if applicable) the thrust bearing housing must be re-lubricated more frequently.

7.2.2.1.2 Grease quality

Optimum grease properties for rolling element bearings

- High melting point lithium soap base grease
- Resin-free and acid-free
- Not liable to crumble
- Rust-preventive characteristics

7.2.2.1.3 Grease quantity

Use 15 grams of grease per bearing.

7.2.2.1.4 Re-lubricating with grease

	<p>! WARNING</p>
	<p>Work in the immediate vicinity of rotating parts Risk of hand injuries!</p> <ul style="list-style-type: none"> ▷ Always have this work performed by trained personnel. ▷ Take particular caution when performing this work.

	<p>CAUTION</p>
	<p>Contaminated lubricating nipples Contamination of the lubricating grease!</p> <ul style="list-style-type: none"> ▷ Clean the grease lubricating nipples before re-lubricating them.

1. Clean the lubricating nipples, if contaminated.
2. Position the grease press on the lubricating nipple.
3. Press in the grease.

7.3 Drainage/cleaning

	<p>! WARNING</p>
	<p>Fluids handled, consumables and supplies which are hot and/or pose a health hazard Hazard to persons and the environment!</p> <ul style="list-style-type: none"> ▷ Collect and properly dispose of flushing fluid and any fluid residues. ▷ Wear safety clothing and a protective mask if required. ▷ Observe all legal regulations on the disposal of fluids posing a health hazard.

If the pump set has handled fluids whose residues could lead to corrosion damage in the presence of atmospheric humidity or could ignite upon contact with oxygen, the pump set must be neutralised, and anhydrous inert gas must be blown through the pump to ensure drying.

The pump is fitted with nozzles for draining.
The pump must not be drained while it is in operation!

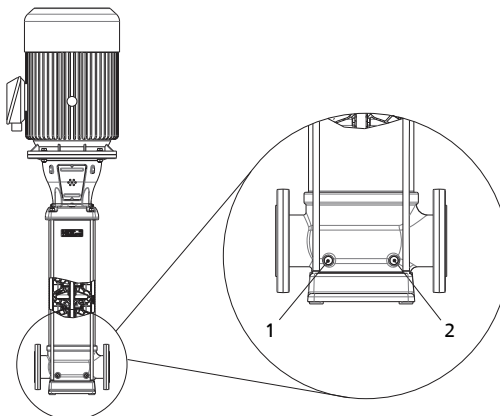





Fig. 11: Connections for draining the pump

1	Connection for draining the suction section	2	Connection for draining the discharge section
---	---	---	---

7.4 Dismantling the pump set

7.4.1 General information/Safety regulations



	<p>⚠ DANGER</p> <p>Insufficient preparation of work on the pump (set) Risk of injury!</p> <ul style="list-style-type: none"> ▷ Properly shut down the pump set. ▷ Close the shut-off elements in the suction line and discharge line. ▷ Drain the pump and release the pump pressure. ▷ Shut off any auxiliary feed lines. ▷ Allow the pump set to cool down to ambient temperature.
	<p>⚠ WARNING</p> <p>Unqualified personnel performing work on the pump (set) Risk of injury!</p> <ul style="list-style-type: none"> ▷ Always have repair work and maintenance work performed by specially trained, qualified personnel.
	<p>⚠ WARNING</p> <p>Hot surface Risk of injury!</p> <ul style="list-style-type: none"> ▷ Allow the pump set to cool down to ambient temperature.
	<p>⚠ WARNING</p> <p>Improper lifting/moving of heavy assemblies or components Personal injury and damage to property!</p> <ul style="list-style-type: none"> ▷ Use suitable transport devices, lifting equipment and lifting tackle to move heavy assemblies or components.

Always observe the safety instructions and information. (⇒ Section 7.1, Page 40)



For any work on the motor, observe the instructions of the relevant motor manufacturer.

For dismantling and reassembly observe the exploded views and the general assembly drawing.

In the event of damage you can always contact our service departments.



	<p>NOTE</p> <p>All maintenance work, service work and installation work can be carried out by KSB Service or authorised workshops. For contact details refer to the enclosed "Addresses" booklet or visit "www.ksb.com/contact" on the Internet.</p>
	<p>NOTE</p> <p>After a prolonged period of operation the individual components may be hard to pull off the shaft. If this is the case, use a brand name penetrating agent and/or - if possible - an appropriate puller.</p>

7.4.2 Preparing the pump set

	 DANGER
	<p>Power supply not disconnected Danger to life!</p> <ul style="list-style-type: none"> ▷ Disconnect all electrical connections from the power supply and secure against unintentional start-up.

1. De-energise the pump set and secure it against unintentional start-up.

7.4.3 Removing the motor

	 WARNING
	<p>Motor tipping over Risk of crushing hands and feet!</p> <ul style="list-style-type: none"> ▷ Suspend or support the motor to prevent it from tipping over.

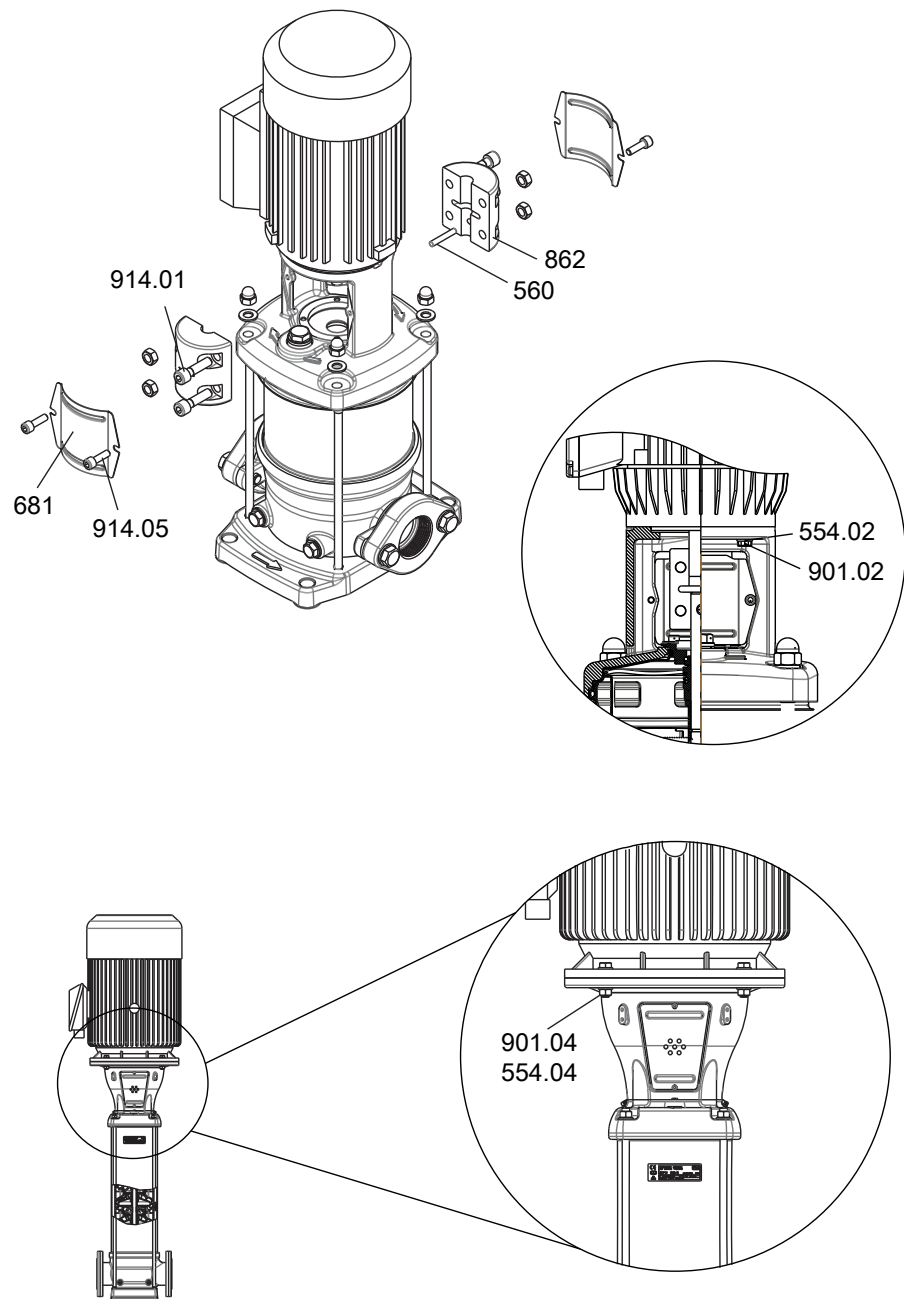

Fig. 12: Removing the motor (example drawing)

✓ The motor has been de-energised.

1. Undo hexagon socket head cap screws 914.05.
2. Remove coupling guard 681.
3. Undo hexagon socket head cap screws 914.01.
4. Take off coupling 862 with pin 560.
5. Unscrew and remove hexagon head bolts 901.02 or 901.04 and washer 554.02 or 554.04.
6. Lift the motor off the pump.

7.4.4 Removing the retaining bracket (optional)

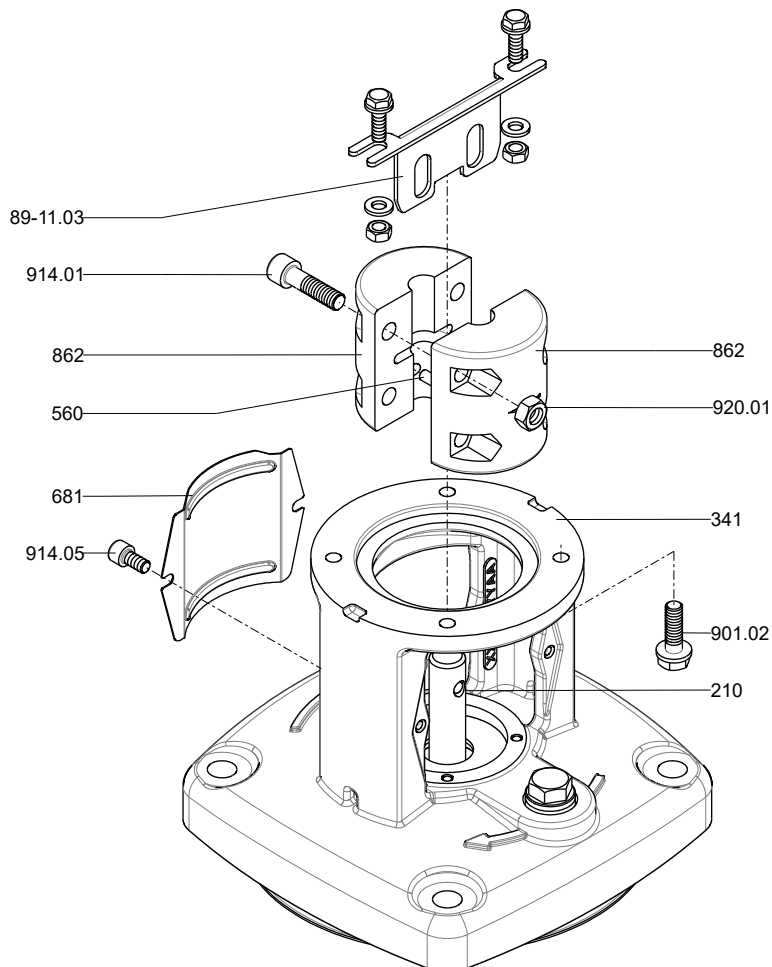

Fig. 13: Removing retaining bracket 89-11.03

✓ The motor has been removed. (⇒ Section 7.4.3, Page 45)

1. Remove retaining bracket 89-11.03

7.4.5 Removing the mechanical seal

7.4.5.1 Fixed mechanical seal

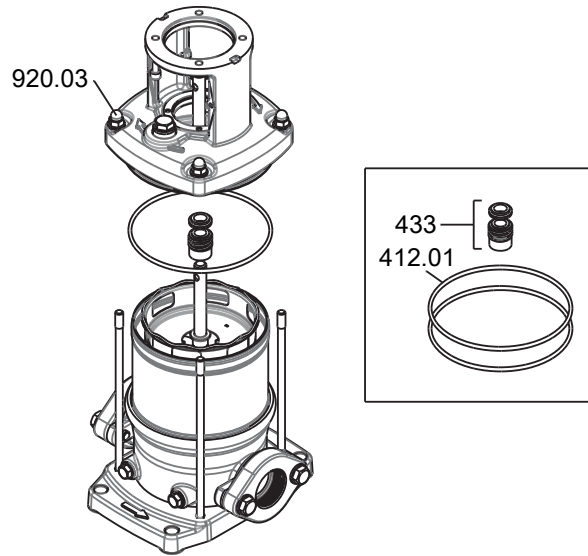

Fig. 14: Removing the mechanical seal (example drawing)

✓ The motor has been removed. (⇒ Section 7.4.3, Page 45)

1. Loosen nuts 920.03 and lift off the drive lantern.
2. Remove mechanical seal 433 and O-rings 412.01.

7.4.5.2 Easy Access mechanical seal

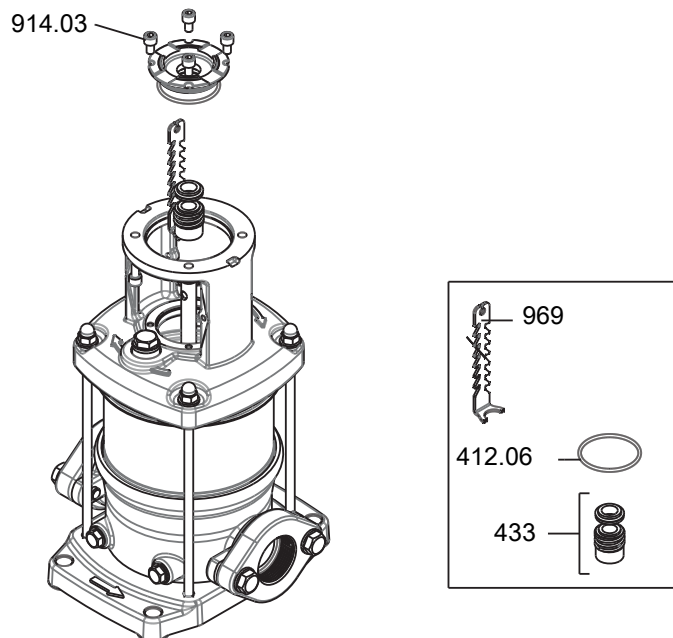

Fig. 15: Removing the mechanical seal (example drawing)

✓ The motor has been removed. (⇒ Section 7.4.3, Page 45)

1. Loosen hexagon socket head cap screws 914.03.
2. Remove O-ring 412.06.
3. Remove mechanical seal 433 using tool 969.

7.4.5.3 Cartridge seal

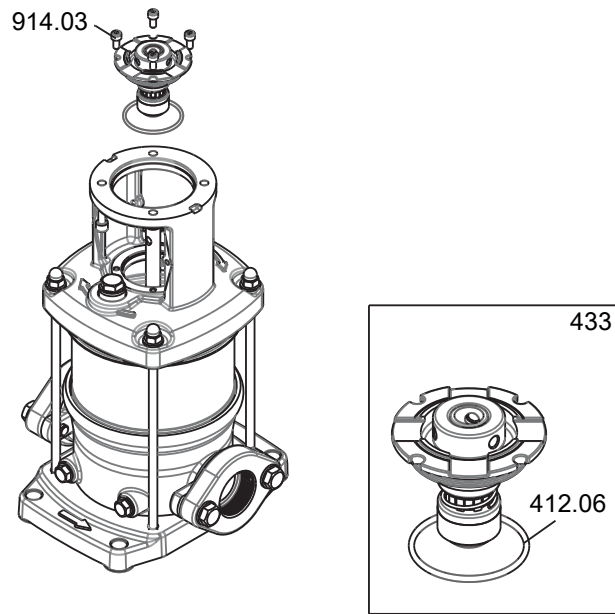





Fig. 16: Removing the mechanical seal (example drawing)
 ✓ The motor has been removed. (⇒ Section 7.4.3, Page 45)
 1. Loosen hexagon socket head cap screws 914.03.
 2. Remove mechanical seal 433.
 3. Remove O-ring 412.06.

7.5 Reassembling the pump set

7.5.1 General information/Safety regulations

	<p>⚠ WARNING</p>
	<p>Improper lifting/moving of heavy assemblies or components Personal injury and damage to property!</p> <ul style="list-style-type: none"> ▸ Use suitable transport devices, lifting equipment and lifting tackle to move heavy assemblies or components.
	<p>CAUTION</p>
	<p>Improper reassembly Damage to the pump!</p> <ul style="list-style-type: none"> ▸ Reassemble the pump (set) in accordance with the general rules of sound engineering practice. ▸ Use original spare parts only.
	<p>NOTE</p>
	<p>Use suitable tools for setting the pump shaft. If necessary, contact KSB.</p>

1798.82/13-EN

Sequence Always reassemble the pump set in accordance with the corresponding general assembly drawing.

- Sealing elements**
- O-rings
 - Check O-rings for any damage and replace by new O-rings, if required.
 - Assembly adhesives
 - Avoid the use of assembly adhesives, if possible.

Tightening torques For reassembly, tighten all screws and bolts as specified in this manual.

7.5.2 Installing the mechanical seal

	<p>! DANGER</p>
<p>Incorrect installation of mechanical seal Abrasion/rubbing of parts! Explosion hazard!</p> <p>▷ Installation should only be carried out by qualified specialist personnel.</p>	

- Installing the mechanical seal** The following rules must be observed when installing the mechanical seal:
- Work cleanly and accurately.
 - Only remove the protective wrapping of the contact faces immediately before installation takes place.
 - Prevent any damage to the sealing surfaces or O-rings.

7.5.2.1 Fixed mechanical seal

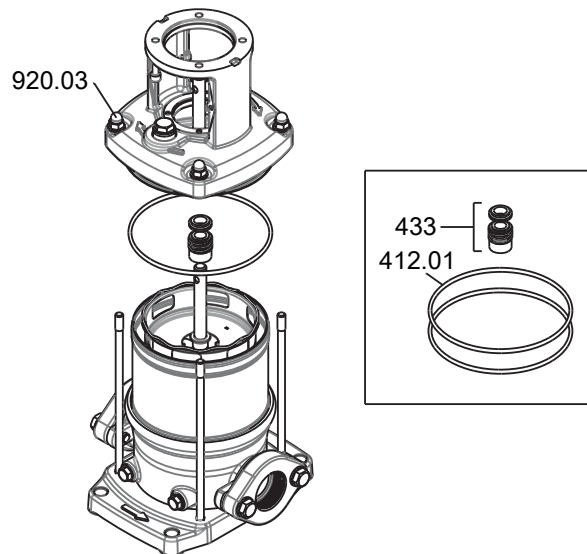

Fig. 17: Installing the mechanical seal (example drawing)

1. Insert mechanical seal 433 and O-rings 412.01.
2. Fit the drive lantern. Screw on nuts 920.03 and tighten them crosswise.
3. Adjust mechanical seal 433. (⇒ Section 7.5.4, Page 54)

7.5.2.2 Easy Access mechanical seal

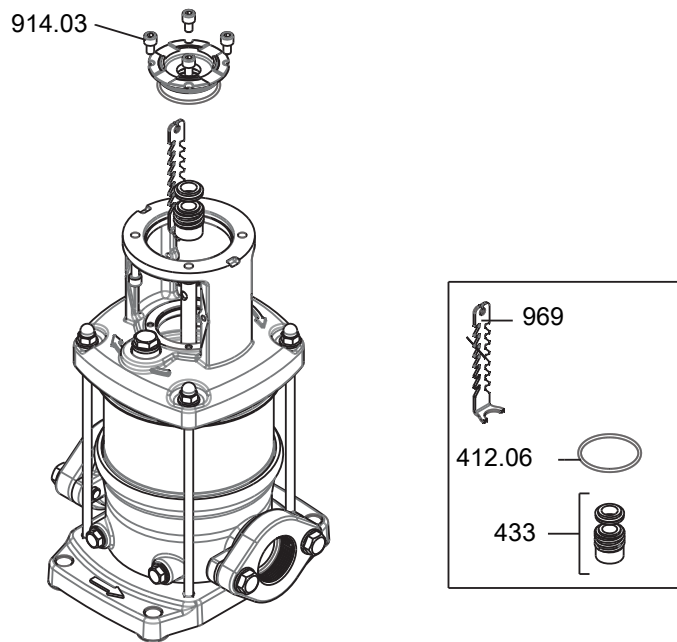

Fig. 18: Installing the mechanical seal (example drawing)

1. Insert mechanical seal 433 using tool 969.
2. Insert O-ring 412.06.
3. Screw in hexagon socket head cap screws 914.03.
4. Adjust mechanical seal 433. (⇒ Section 7.5.4, Page 54)

7.5.2.3 Cartridge seal

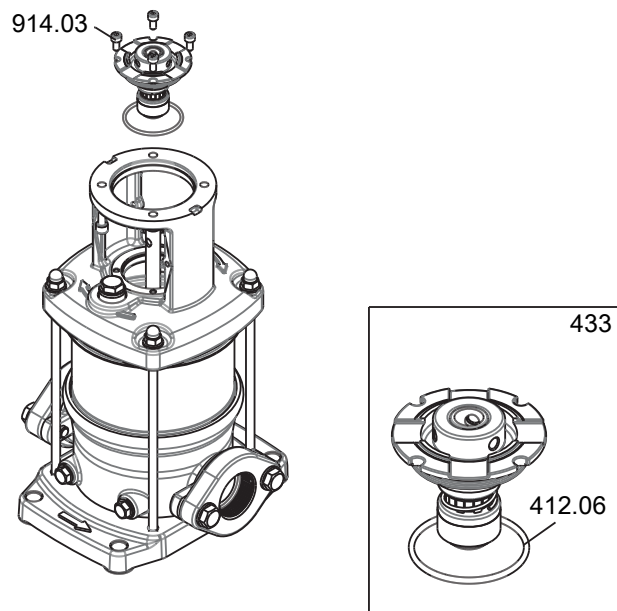

Fig. 19: Installing the mechanical seal (example drawing)

1. Insert O-ring 412.06.
2. Insert mechanical seal 433.
3. Screw in hexagon socket head cap screws 914.03.
4. Adjust mechanical seal 433. (⇒ Section 7.5.4, Page 54)

7.5.3 Mounting the motor

	⚠ WARNING
	Motor tipping over Risk of crushing hands and feet! ▶ Suspend or support the motor to prevent it from tipping over.
	NOTE
	Using a specially designed KSB motor is recommended.

The motor must meet the following conditions:

- Reinforced bearing at the driven end (absorbing the axial forces)
- Motor fastened axially (minimising the axial clearance of the hydraulic system of the pump)
- Non-keywayed shaft (improving the coupling connection and smooth running of the motor)
- The rated power must be suitable for the relevant operating frequency.
- The effective speed must always be complied with for pumps with VdS certification.
- The frame size must be suitable for connecting the motor to the drive lantern.

Table 16: Recommended motor bearings at the drive end

Motor rating [kW]	1-phase 50 Hz	3-phase 50/60 Hz	
		2 poles	4 poles
0,25	-	-	6202-2Z-C3
0,37	6202-2Z-C3	6203-2Z-C3	6202-2Z-C3
0,55	6202-2Z-C3	6203-2Z-C3	6202-2Z-C3
0,75	6204-2Z-C3	6204-2Z-C3	6202-2Z-C3
1,1	6204-2Z-C3	6204-2Z-C3	6205-2Z-C3
1,5	6305-2Z-C3	6305-2Z-C3	6205-2Z-C3
2,2	6305-2Z-C3	6305-2Z-C3	6206-2Z-C3
3,0	-	6306-2Z-C3	6206-2Z-C3
4,0	-	6306-2Z-C3	6208-2Z-C3
5,5	-	6308-2Z-C3	6208-2Z-C3
7,5	-	6308-2Z-C3	6208-2Z-C3
11,0	-	7309-BEP	-
15,0	-	7309-BEP	-
18,5	-	7309-BEP	-
22,0	-	7311-BEP	-
30,0	-	7312-BEP	-
37,0	-	7312-BEP	-
45,0	-	7313-BEP	-

If a thrust bearing housing is used:

	CAUTION
	<p>The axial clearance between the thrust bearing housing shaft and the motor shaft is set incorrectly.</p> <p>Risk of high impacts from thrust bearing housing shaft and motor shaft knocking against each other!</p> <p>Increased load on and wear of the rolling element bearings!</p> <p>▷ The electric motor must be mounted on the thrust bearing housing by a trained and duly qualified certified mechanic.</p>

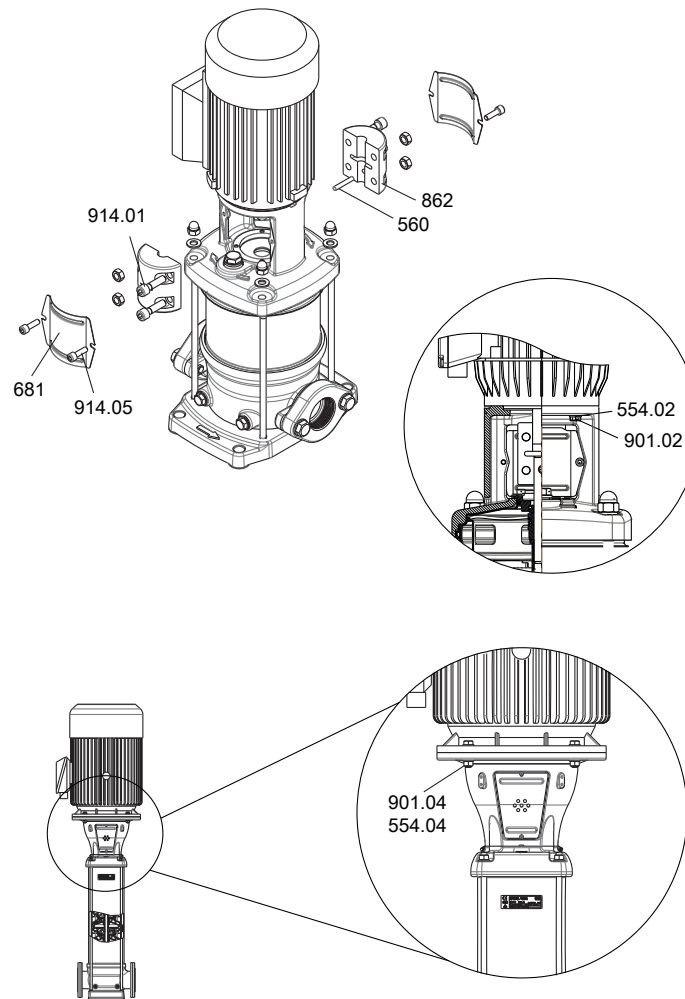
Fig. 20: Mounting the motor

✓ Retaining bracket 89-11.03 (if applicable) has been removed.
 (⇒ Section 7.4.4, Page 47)

1. Align the motor on the drive lantern.
2. Screw in hexagon head bolts 901.02 or 901.04 and washer 554.02 or 554.04.

	CAUTION
	<p>Incorrect installation of coupling</p> <p>Damage to the machinery!</p> <p>▷ The coupling must be installed by qualified specialist personnel.</p>

3. Insert coupling 862 with pin 560.
4. Screw in hexagon socket head cap screws 914.01.

5. Fit coupling guard 681.
6. Screw in hexagon socket head cap screws 914.05.

7.5.4 Adjusting the mechanical seal, coupling and pump shaft

	NOTE
	Use suitable tools for setting the pump shaft. If necessary, contact KSB.
	NOTE
	Motors ≥ 11 kW: lock rotor before adjusting the coupling. This will prevent the rotor from being lifted out of the bearings.

Movitec B, C – Fixed mechanical seal / Easy Access mechanical seal

- ✓ The motor has been mounted on the pump. (⇒ Section 7.5.3, Page 52)
 - ✓ Coupling 862 has been fastened with pin 560 and hexagon socket head cap screws 914.01.
1. Loosen hexagon socket head cap screws 914.01 by one turn each.
 2. Lower the coupling 862 to its lowest position, then raise it again by 1.5 mm.

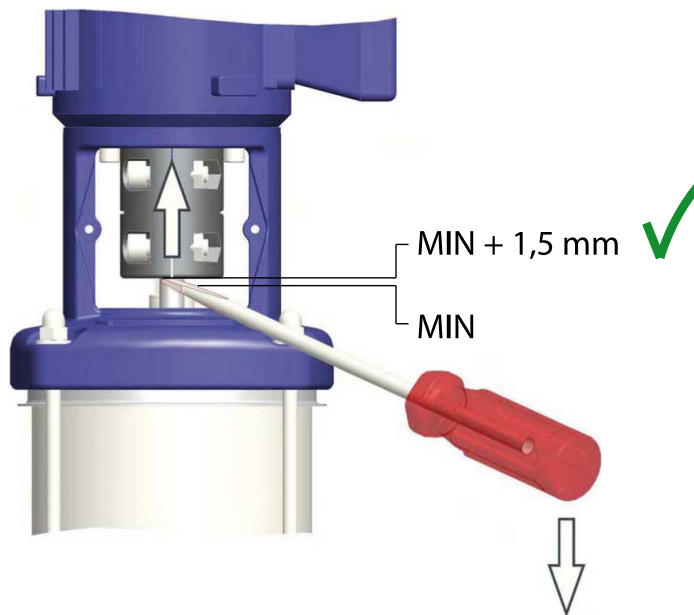

3. Verify that no clearances remain between the coupling halves, and fasten the coupling in this position.

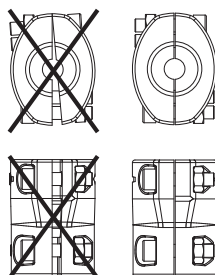

4. Apply a thread-locking agent (e.g. Loctite 2400).
5. Fit coupling guard 681 and fasten it with hexagon socket head cap screws 914.05. Tighten the screws.

Movitec B, C – cartridge seal

✓ The motor has been mounted on the pump. (⇒ Section 7.5.3, Page 52)

✓ Coupling 862 has been fastened with pin 560 and screws 914.01.

1. Adjust grub screws 904.
2. Loosen hexagon socket head cap screws 914.01 by one turn each.
3. Apply a thread-locking agent (e.g. Loctite 2400).
4. Move coupling 862 into its lowest position.
5. Tighten grub screws 904.
6. Raise coupling 862 by 1.5 mm.

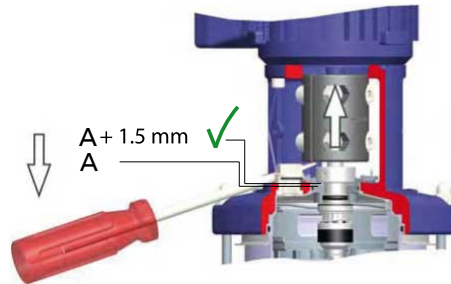

7. Tighten hexagon socket head cap screws 914.04.

8. Verify that no clearances remain between the coupling halves, and fasten the coupling in this position.

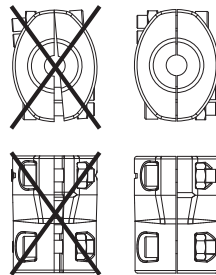

9. Mount coupling guard 681 and ATEX-compliant external guard 680, if any.

10. Apply thread-locking agent (e.g. Loctite 2400) to hexagon socket head cap screws 914.05.

Movitec LHS 6

- ✓ The motor has been mounted on the pump. (⇒ Section 7.5.3, Page 52)
- ✓ Coupling 862 has been fastened with pin 560 and hexagon socket head cap screws 914.01.

1. Raise coupling 862 to its highest position, then lower it again by 1 mm.

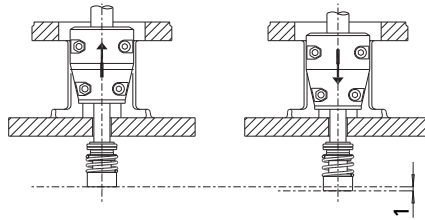

2. Verify that no clearances remain between the coupling halves, and fasten the coupling in this position.

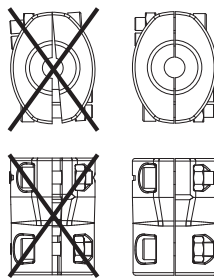

3. Install coupling guard 681.

4. Apply thread-locking agent (e.g. Loctite 2400) to hexagon socket head cap screws 914.05.

7.6 Tightening torques

Table 17: Tightening torques [Nm]

Part No.	Description	Movitec								Thread	[Nm]
		V(C/S) 2 - 15 B	V(C/S) 15 C	V(C/S) 25 B	V(C/S) 25 - 90 B	V(C/S) 40 - 90 B	V(C/S) 125 B 16 bar	V(C/S) 125 B 25 bar	LHS 6		
801	Flanged motor	X	X	-	X	-	X	X	X	M6	10
										M8	10
										M12	70
										M16	70
903.01	Screw plug, filling in / topping up oil	X	X	-	X	-	X	X	-	G 3/8	10
		-	-	-	-	-	-	-	X	G 3/8	20
903.02	Screw plug, draining fluid handled	X	X	-	X	-	X	X	-	G 1/4	10
		-	-	-	-	-	-	-	X	M10	20
914.01	Hexagon socket head cap screw	X	X	-	X	-	X	X	X	M8 aluminium	22
		X	X	-	X	-	X	X	X	M10 steel / grey cast iron	70
914.02	Hexagon socket head cap screw	X	X	-	X	-	X	X	X	M6	10
		X	X	-	X	-	X	X	X	M8	10
		X	X	-	X	-	X	X	X	M12	70
		X	X	-	X	-	X	X	X	M16	70

1798.82/13-EN

Part No.	Description	Movitec								Thread	[Nm]
		V(C/S) 2 - 15 B	V(C/S) 15 C	V(C/S) 25 B	V(C/S) 25 - 90 B	V(C/S) 40 - 90 B	V(C/S) 125 B 16 bar	V(C/S) 125 B 25 bar	LHS 6		
914.03	Hexagon socket head cap screw, seal cover	X	X	-	X	-	X	X	X	M5	4 ⁺²
		X	X	-	X	-	X	X	X	M6	10
		X	X	-	X	-	X	X	X	M8	10
920.02	Nut, shaft	X	-	-	-	-	-	-	-	M10	28
		-	X	-	-	-	-	-	-	M12	38
		-	-	-	X	-	-	-	-	M12	50
		-	-	-	-	-	X	X	-	M16	100
		-	-	-	-	-	-	-	X	M10	40
920.03	Nut, tie bolt	X	X	-	X	-	-	-	-	M8	12
		X	X	-	X	-	-	-	-	M12	25
		-	-	X	-	-	-	-	-	M16	60
		-	-	-	-	X	-	-	-	M16	85
		-	-	-	-	-	X	-	-	M20	55
		-	-	-	-	-	-	X	-	M20	85
		-	-	-	-	-	-	-	X	M16	80

7.7 Spare parts stock

7.7.1 Ordering spare parts

Always quote the following data when ordering replacement or spare parts:



- Order number
- Order item number
- Consecutive number
- Type series
- Size
- Material variant
- Seal code
- Year of construction

Refer to the name plate for all data.

Also specify the following data:

- Part number and description (⇒ Section 9.1, Page 60)
- Quantity of spare parts
- Shipping address
- Mode of dispatch (freight, mail, express freight, air freight)

8 Trouble-shooting

	 WARNING
	<p>Improper work to remedy faults</p> <p>Risk of injury!</p> <p>▷ For any work performed to remedy faults, observe the relevant information given in this operating manual and/or in the product literature provided by the accessories manufacturer.</p>

If problems occur that are not described in the following table, consultation with the KSB service is required.

Table 18: Trouble-shooting

Problem	Possible cause	Remedy
Leakage along the shaft	Seal faces of the primary rings of the mechanical seal worn or damaged	<ul style="list-style-type: none"> ▪ Replace the shaft seal. ▪ Check pump for impurities.
	Axial movement of the mechanical seal is restricted because it is stuck.	<ul style="list-style-type: none"> ▪ Quickly open and close the discharge-side valve during operation.
	Shaft seal fitted incorrectly	<ul style="list-style-type: none"> ▪ Re-install shaft seal correctly (use water and soap as a lubricant).
	Elastomers damaged by the fluid handled	<ul style="list-style-type: none"> ▪ Use a suitable elastomer for the shaft seal.
	Total operating pressure too high	<ul style="list-style-type: none"> ▪ Use a shaft seal with suitable pressure class.
	Shaft is damaged.	<ul style="list-style-type: none"> ▪ Replace the shaft.
	Pump running dry	<ul style="list-style-type: none"> ▪ Replace the shaft seal.
Leakage at the casing cover and the lower section of the pump casing	O-ring worn	<ul style="list-style-type: none"> ▪ Replace the O-ring.
	O-ring not resistant to fluid handled	<ul style="list-style-type: none"> ▪ Replace O-ring with O-ring made of suitable material.
	Pump not installed free from stresses and strains	<ul style="list-style-type: none"> ▪ Connect the piping properly.
Pump vibrates and causes running noises.	Coupling fitted incorrectly	<ul style="list-style-type: none"> ▪ Make sure the coupling halves are parallel.
	Rotor adjusted incorrectly	<ul style="list-style-type: none"> ▪ Re-adjust rotor.
	Pump not primed.	<ul style="list-style-type: none"> ▪ Prime and vent the pump.
	No or insufficient inflow	<ul style="list-style-type: none"> ▪ Provide sufficient supply. ▪ Check inlet line for clogging.
	Bearings of pump and/or motor defective	<ul style="list-style-type: none"> ▪ Replace bearings.
	NPSH available too low (cavitation)	<ul style="list-style-type: none"> ▪ Improve suction conditions.
	Pump not working in its operating range	<ul style="list-style-type: none"> ▪ Adjust system to operation within operating range or select different pump.
	Pump clogged	<ul style="list-style-type: none"> ▪ Clean the pump.
Pump does not start.	No voltage at the terminals	<ul style="list-style-type: none"> ▪ Check power supply (circuit, master switch, fuses).
	Thermal motor protection device has tripped.	<ul style="list-style-type: none"> ▪ Re-set thermal motor protection (I_{nom} see name plate).
Motor running but pump does not start.	Motor shaft defective	<ul style="list-style-type: none"> ▪ Contact supplier.
	Pump shaft defective	<ul style="list-style-type: none"> ▪ Contact supplier.
	Shaft coupling has become loose.	<ul style="list-style-type: none"> ▪ Tighten the fastening screws.

Problem	Possible cause	Remedy
Insufficient delivery and/or insufficient pressure	Valves in suction and discharge lines closed	<ul style="list-style-type: none"> ▪ Open the shut-off elements.
	Air in the pump	<ul style="list-style-type: none"> ▪ Vent the pump.
	Insufficient inlet pressure	<ul style="list-style-type: none"> ▪ Increase inlet pressure.
	Wrong direction of rotation	<ul style="list-style-type: none"> ▪ Check electrical connection.
	Suction line not vented.	<ul style="list-style-type: none"> ▪ Vent suction line.
	Air pocket in suction line	<ul style="list-style-type: none"> ▪ Lay suction line with a rising slope towards the pump.
	Pump takes in air due to leakage in suction line.	<ul style="list-style-type: none"> ▪ Repair.
	Insufficient flow rate leads to air remaining in the pump.	<ul style="list-style-type: none"> ▪ Use smaller pump. ▪ Increase the (volume) flow rate.
	Diameter of suction line too small	<ul style="list-style-type: none"> ▪ Increase diameter of suction line.
	Foot valve clogged.	<ul style="list-style-type: none"> ▪ Clean the foot valve.
	Impeller or diffuser clogged	<ul style="list-style-type: none"> ▪ Clean the pump.
	O-ring not resistant to fluid handled	<ul style="list-style-type: none"> ▪ Replace O-ring with O-ring made of suitable material.

9 Related Documents

9.1 General assembly drawings/exploded views with list of components

9.1.1 Movitec 2(L)B, 4(L)B, 6(L)B

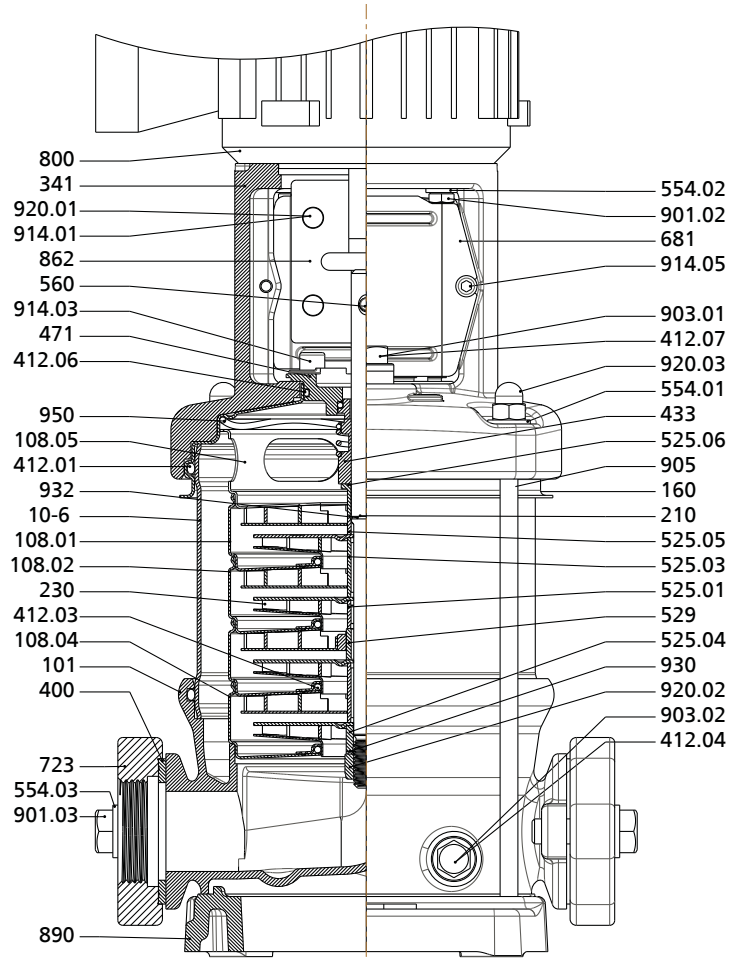

Fig. 21: General assembly drawing of Movitec 2(L)B, 4(L)B, 6(L)B

Table 19: List of components

Part No.	Description	Part No.	Description
10-6	Pump shroud	560	Pin
101	Pump casing	681	Coupling guard
108.01/02/04/05	Stage casing	723	Flange
160	Cover	800	Motor
210	Shaft	862	Coupling
230	Impeller	890	Baseplate
341	Drive lantern	901.02/03	Hexagon head bolt
400	Gasket	903.01	Screw plug
412.01/03/04/06/07	O-ring	905	Tie bolt
433	Mechanical seal	914.01/03/05	Hexagon socket head cap screw
471	Seal cover	920.01/02/03	Nut
525.01/03/04/05/06	Spacer sleeve	930	Safety device
529	Bearing sleeve	932	Circlip
554.01/03	Washer	950	Spring

9.1.2 Movitec 10(L)B, 15(L)B

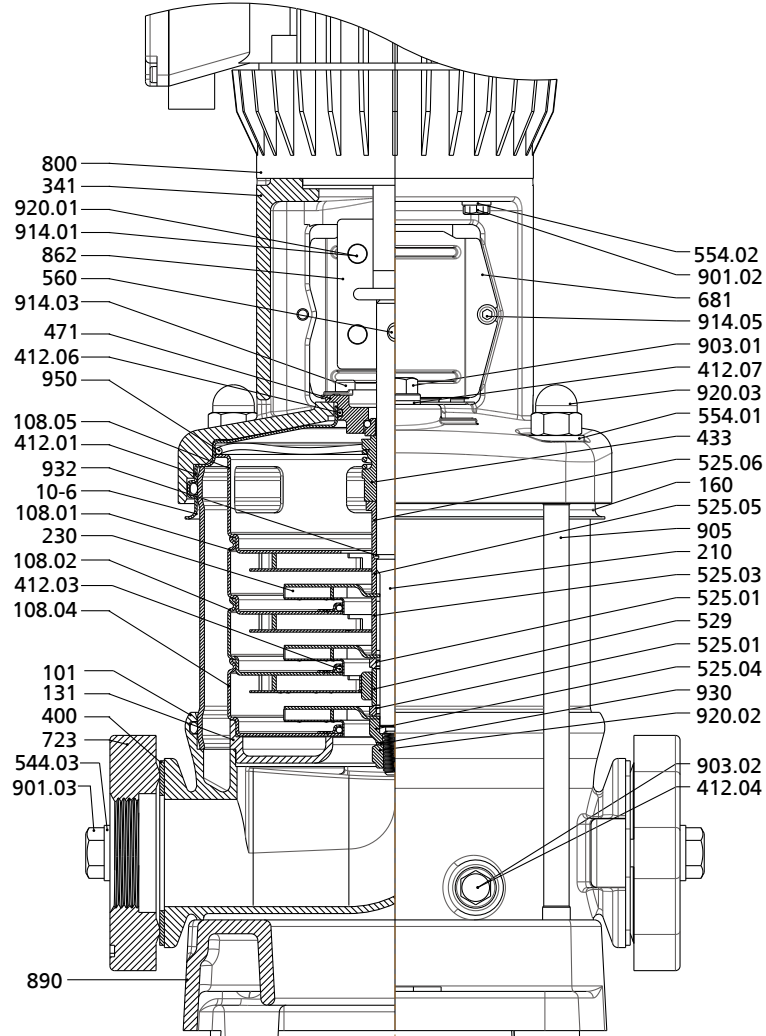

Fig. 22: General assembly drawing of Movitec 10(L)B, 15(L)B

Table 20: List of components

Part No.	Description	Part No.	Description
10-6	Pump shroud	554.01/02	Washer
101	Pump casing	560	Pin
108.01/02/04/05	Stage casing	681	Coupling guard
131	Inlet ring	723	Flange
160	Cover	800	Motor
210	Shaft	862	Coupling
230	Impeller	890	Baseplate
341	Drive lantern	901.02/03	Hexagon head bolt
400	Gasket	903.01/02	Screw plug
412	O-ring	905	Tie bolt
433	Mechanical seal	914.01/03/05	Hexagon socket head cap screw
471	Seal cover	920.01/02/03	Nut
525.01/03/04/05/06	Spacer sleeve	930	Safety device
529	Bearing sleeve	932	Circlip
544.03	Threaded bush	950	Spring

1798.82/13-EN

9.1.3 Movitec 15(L)C

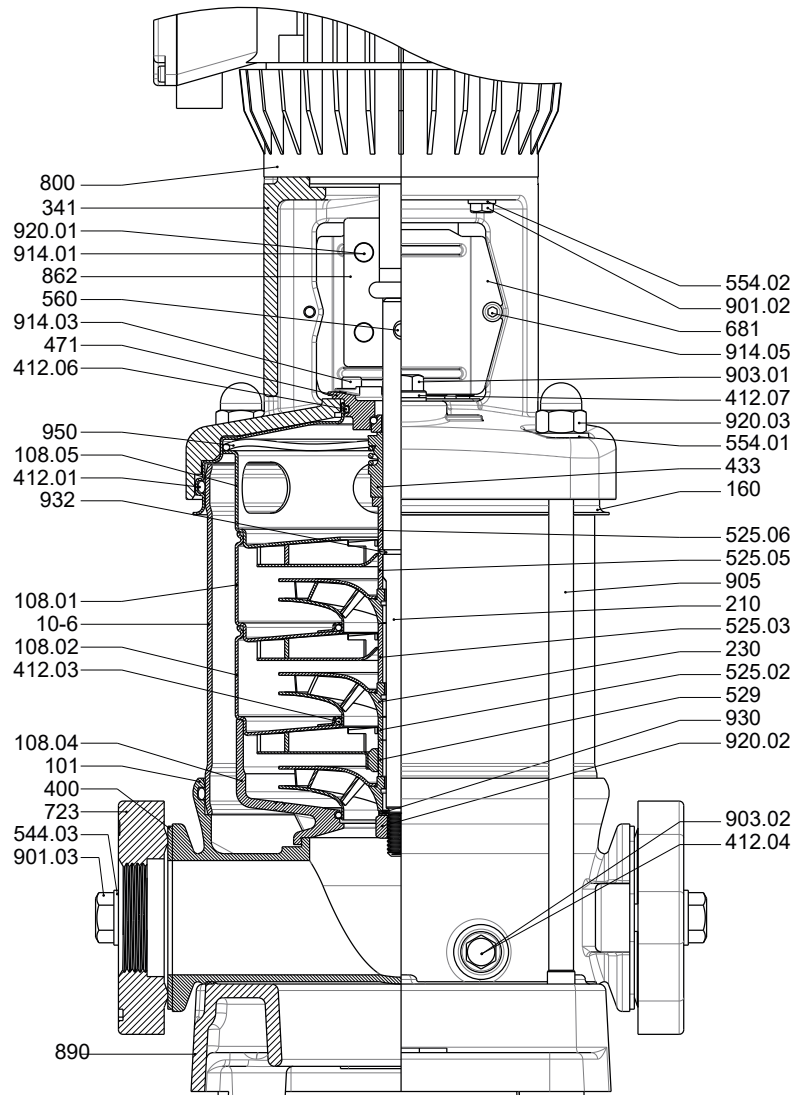

Fig. 23: General assembly drawing of Movitec 15(L)C

Table 21: List of components

Part No.	Description	Part No.	Description
10-6	Pump shroud	560	Pin
101	Pump casing	681	Coupling guard
108.01/.02/.04/.05	Stage casing	723	Flange
160	Cover	800	Motor
210	Shaft	862	Coupling
230	Impeller	890	Baseplate
341	Drive lantern	901.02/.03	Hexagon head bolt
400	Gasket	903.01/.02	Screw plug
412.01/.03/.04/.06/.07	O-ring	905	Tie bolt
433	Mechanical seal	914.01/.03/.05	Hexagon socket head cap screw
471	Seal cover	920.01/.02/.03	Nut
525.02/.03/.05/.06	Spacer sleeve	930	Safety device
529	Bearing sleeve	932	Circlip
544.03	Threaded bush	950	Spring
554.01/.02	Washer		

1798.82/13-EN

9.1.4 Movitec 25B

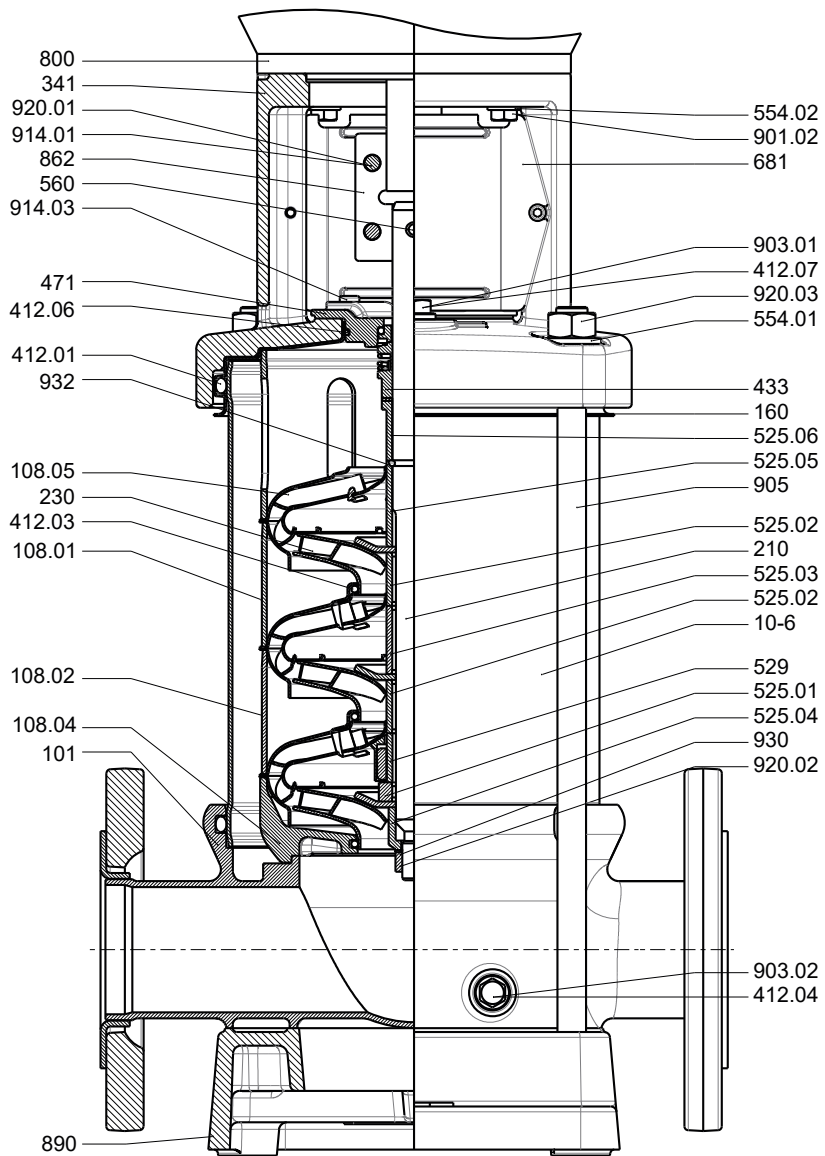

Fig. 24: General assembly drawing of Movitec 25B

Table 22: List of components

Part No.	Description	Part No.	Description
10-6	Pump shroud	560	Pin
101	Pump casing	681	Coupling guard
108.01/.02/.04/.05	Stage casing	800	Motor
160	Cover	862	Coupling
210	Shaft	890	Baseplate
230	Impeller	901.02	Hexagon head bolt
341	Drive lantern	903.01/.02	Screw plug
412.01/.03/.04/.06/.07	O-ring	905	Tie bolt
433	Mechanical seal	914.01/.03	Hexagon socket head cap screw
471	Seal cover	920.01/.02/.03	Nut
525.01/.02/.03/.04/.05/.06	Spacer sleeve	930	Safety device
529	Bearing sleeve	932	Circlip
554.01/.02	Washer		

1798.82/13-EN

9.1.5 Movitec 40B, 60B

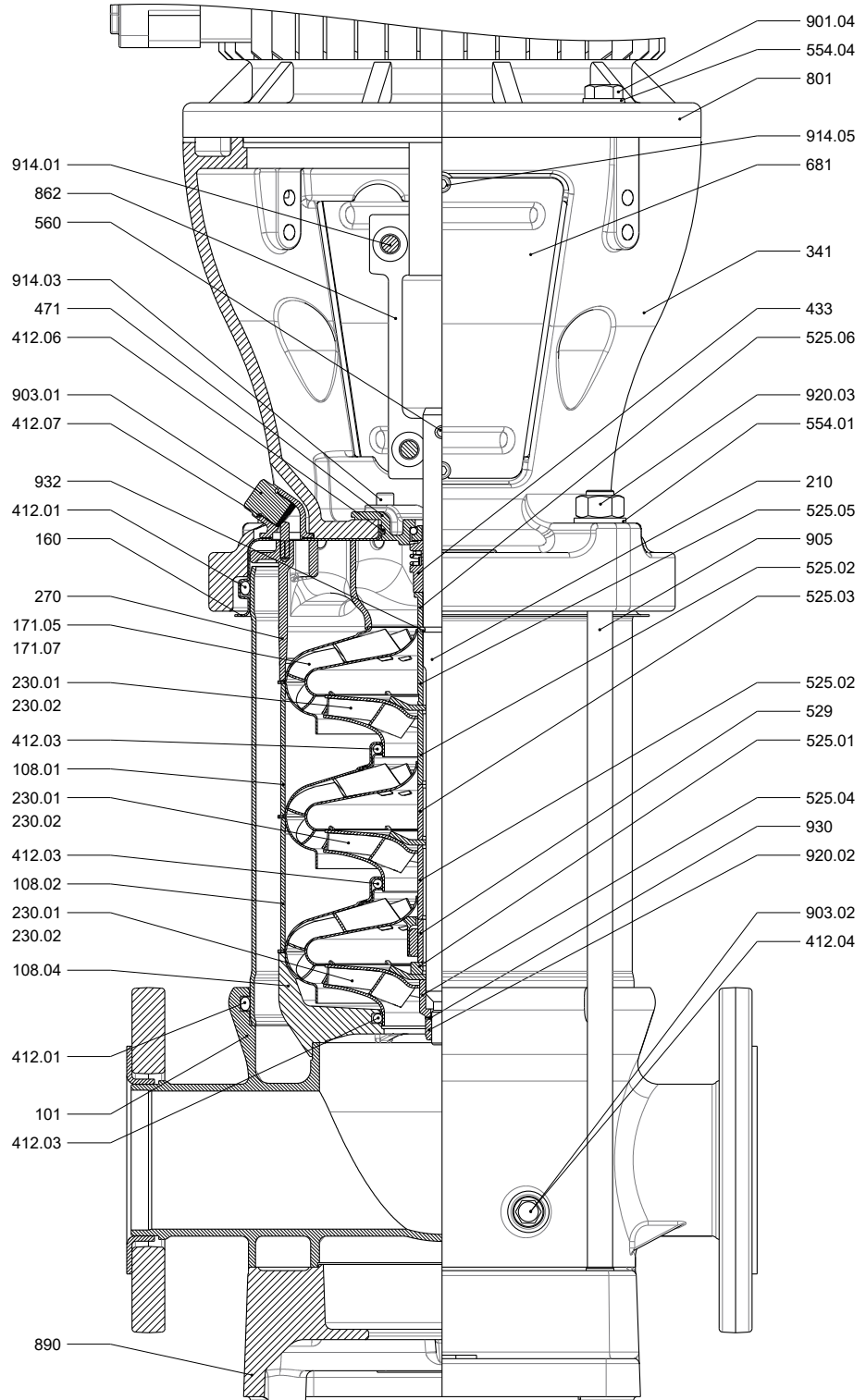

Fig. 25: General assembly drawing of Movitec 40B, 60B

Table 23: List of components

Part No.	Description	Part No.	Description
10-6	Pump shroud	554.01/02	Washer
101	Pump casing	560	Pin
108.01/02/04/05	Stage casing	681	Coupling guard
160	Cover	801	Flanged motor
171.05/07	Diffuser	862	Coupling

1798.82/13-EN

Part No.	Description	Part No.	Description
210	Shaft	890	Baseplate
230	Impeller	901.02	Hexagon head bolt
270	Deflector	903.01/02	Screw plug
341	Drive lantern	905	Tie bolt
412.01/03/04/06/07	O-ring	914.01/03	Hexagon socket head cap screw
433	Mechanical seal	920.01/02/03	Nut
471	Seal cover	930	Safety device
525.01/02/03/04/05/06	Spacer sleeve	932	Circlip
529	Bearing sleeve		

9.1.6 Movitec 90B

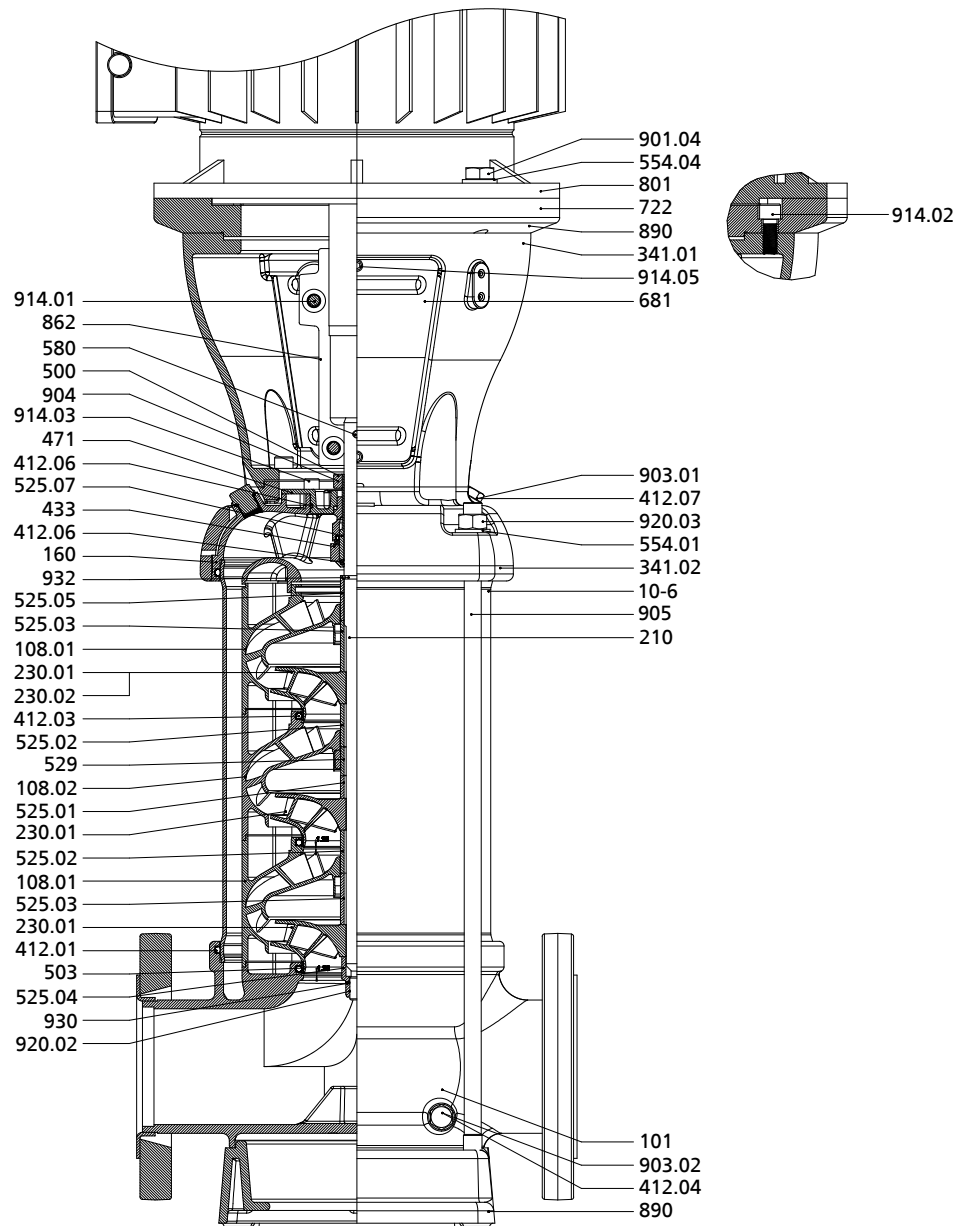

Fig. 26: General assembly drawing of Movitec 90B

1798.82/13-EN

Table 24: List of components

Part No.	Description	Part No.	Description
10-6	Pump shroud	580	Cap
101	Pump casing	681	Coupling guard
108.01/02	Stage casing	722	Flange adapter
160	Cover	801	Flanged motor
210	Shaft	862	Coupling
230.01/02	Impeller	890	Baseplate
341.01/02	Drive lantern	901.04	Hexagon head bolt
412.01/03/04/06/07	O-ring	903	Screw plug
433	Mechanical seal	904	Grub screw
471	Seal cover	905	Tie bolt
500	Ring	914.01/02/03/05	Hexagon socket head cap screw
503	Impeller wear ring	920.02/03	Nut
525.01/02/03/04/05/07	Spacer sleeve	930	Safety device
529	Bearing sleeve	932	Circlip
544.01/04	Threaded bush		

9.1.7 Movitec 125B

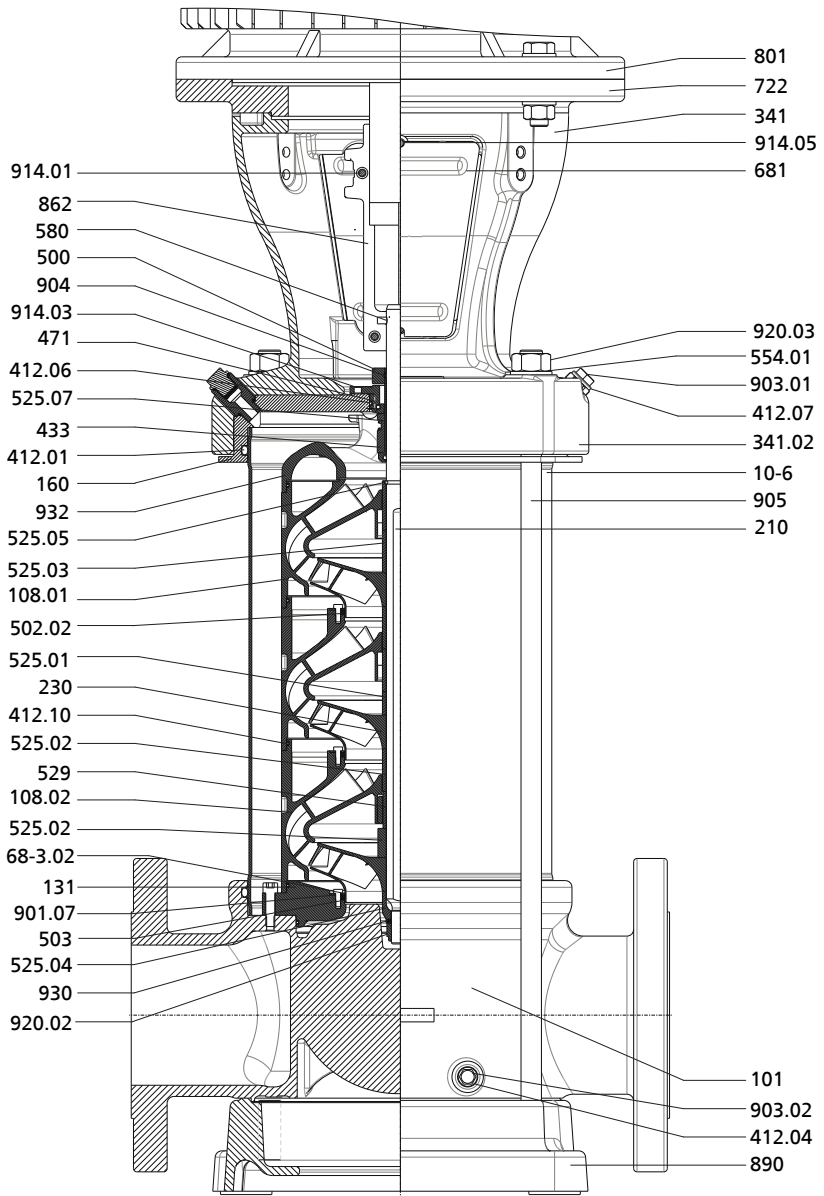

Fig. 27: General assembly drawing of Movitec 125B

Table 25: List of components

Part No.	Description	Part No.	Description
10-6	Pump shroud	554.01	Washer
101	Pump casing	580	Cap
108.01/02	Stage casing	68-3.02	Cover plate
131	Inlet ring	681	Coupling guard
160	Cover	722	Stub flange
210	Shaft	801	Flanged motor
230	Impeller	862	Coupling
341.02	Drive lantern	890	Baseplate
412.01/04/06/07/10	O-ring	901.07	Hexagon head bolt
433	Mechanical seal	903.01/02	Screw plug
471	Seal cover	904	Grub screw
500	Ring	905	Tie bolt

1798.82/13-EN

Part No.	Description	Part No.	Description
502.02	Casing wear ring	914.01/03/05	Hexagon socket head cap screw
503	Impeller wear ring	920.02/03	Nut
525.01/02/03/04/05/07	Spacer sleeve	930	Safety device
529	Bearing sleeve	932	Circlip

9.1.8 Movitec LHS

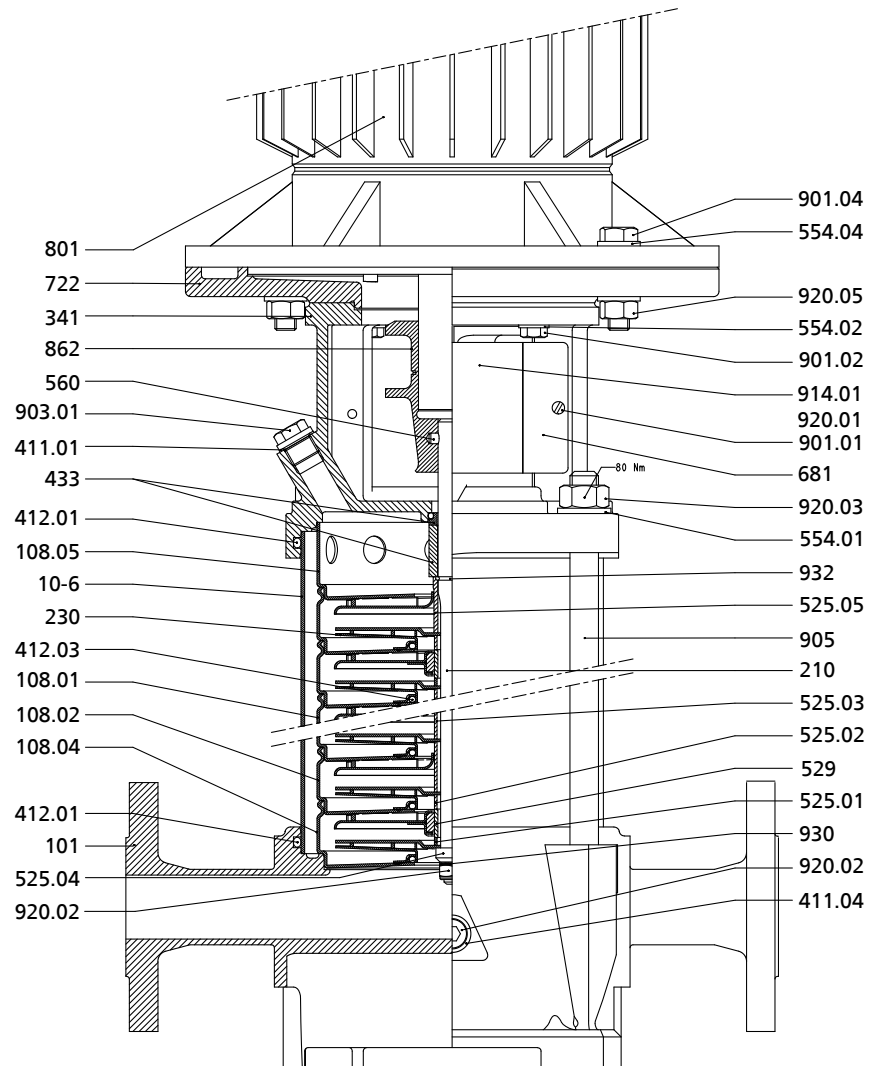

Fig. 28: General assembly drawing of Movitec LHS

Table 26: List of components

Part No.	Description	Part No.	Description
10-6	Pump shroud	560	Pin
101	Pump casing	681	Coupling guard
108.01/02/04/05	Stage casing	722	Flange adapter
210	Shaft	801	Flanged motor
230	Impeller	862	Coupling
341	Drive lantern	901.01/02/04	Hexagon head bolt
411.01/03	Joint ring	903.01	Screw plug
412.01/03	O-ring	905	Tie bolt
433	Mechanical seal	914.01	Hexagon socket head cap screw

1798.82/13-EN

Part No.	Description	Part No.	Description
525.01/02/03/04/05	Spacer sleeve	920.01/02/03/05	Nut
529	Bearing sleeve	930	Safety device
554.01/02/04	Washer	932	Circlip

9.1.9 Motor

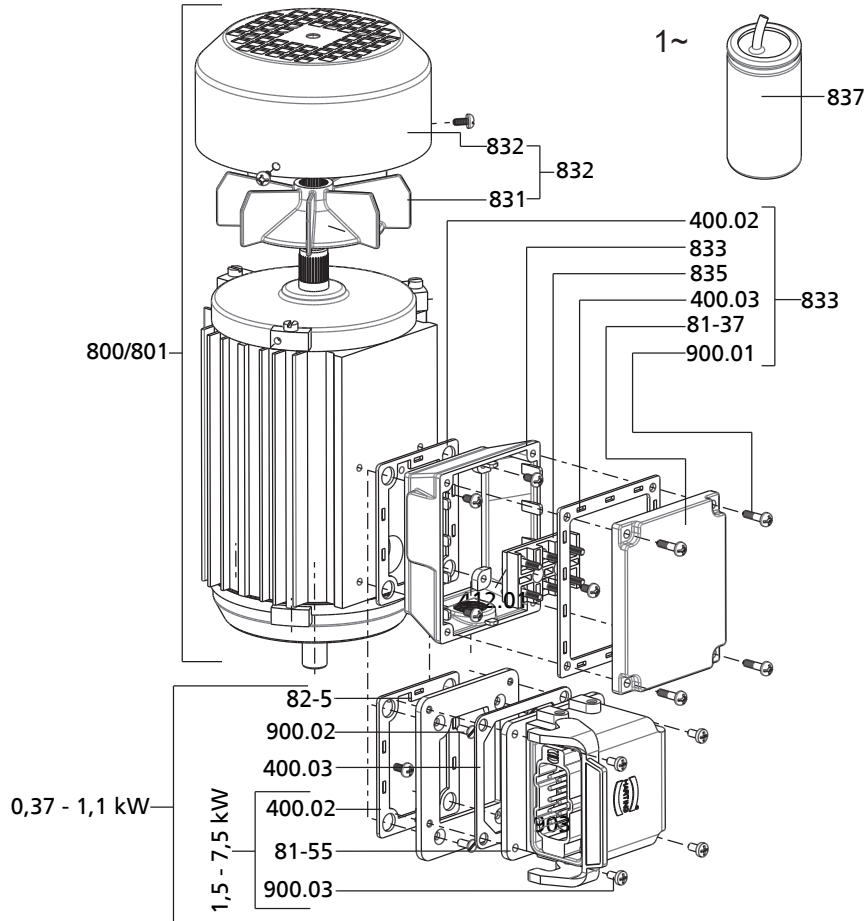

Fig. 29: Exploded view of motor

Table 27: List of components

Part No.	Description	Part No.	Description
400	Gasket	831	Fan impeller
800	Motor	832	Fan hood
801	Flanged motor	833	Terminal box
81-37	Terminal box cover	835	Terminal board
81-55	Socket	837	Capacitor
82-5	Adapter	900	Screw

9.2 Wiring diagram

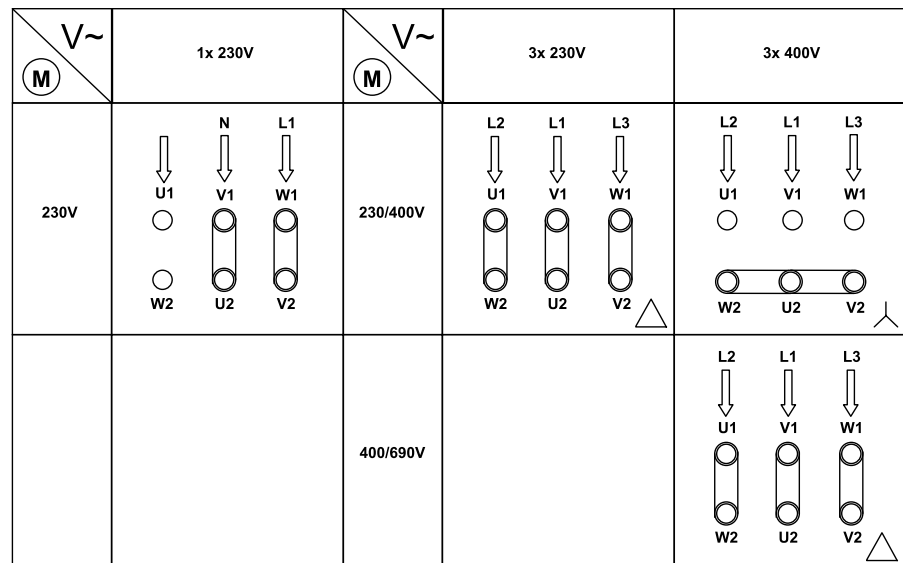

Fig. 30: Wiring diagram, depending on selected motor

10 EU Declaration of Conformity

Manufacturer: **KSB B.V.**
Kalkovenweg 13
2401 LJ Alphen aan den Rijn (The Netherlands)

This EU Declaration of Conformity is issued under the sole responsibility of the manufacturer.

The manufacturer herewith declares that **the product:**

Movitec

Serial number: 40/2021 1000000-1 - 52/2023 9999999-999

- is in conformity with the provisions of the following directives / regulations as amended from time to time:
 - Pump (set): 2006/42/EC Machinery Directive
 - Ecodesign Directive 2009/125/EC, Regulation No. 547/2012 (for water pumps with a maximum shaft power of 150 kW)
 - Electrical components²¹: 2011/65/EU Restriction of the use of certain hazardous substances in electrical and electronic equipment (RoHS)

The manufacturer also declares that

- the following harmonised international standards have been applied:
 - ISO 12100
 - EN 809

Person authorised to compile the technical file:

Menno Schaap
Manager Competence Centre Products
KSB B.V.
(Subsidiary D.P. Industries B.V.)
Kalkovenweg 13
2401 LJ Alphen aan den Rijn (The Netherlands)

The EU Declaration of Conformity was issued in/on:

Alphen aan den Rijn, 11 October 2021



Menno Schaap
Manager Competence Centre Products
KSB B.V.
Kalkovenweg 13
2401 LJ Alphen aan den Rijn

²¹ Where applicable

11 Certificate of Decontamination

Type:
 Order number /
 Order item number²²⁾:
 Delivery date:
 Application:
 Fluid handled²²⁾:

Please tick where applicable²²⁾:



Corrosive



Oxidising



Flammable



Explosive



Hazardous to health



Seriously hazardous to health



Toxic



Radioactive



Bio-hazardous



Safe

Reason for return:²²⁾

Comments:

The product / accessories have been carefully drained, cleaned and decontaminated inside and outside prior to dispatch / placing at your disposal.

We herewith declare that this product is free from hazardous chemicals and biological and radioactive substances.

For mag-drive pumps, the inner rotor unit (impeller, casing cover, bearing ring carrier, plain bearing, inner rotor) has been removed from the pump and cleaned. In cases of containment shroud leakage, the outer rotor, bearing bracket lantern, leakage barrier and bearing bracket or intermediate piece have also been cleaned.

For canned motor pumps, the rotor and plain bearing have been removed from the pump for cleaning. In cases of leakage at the stator can, the stator space has been examined for fluid leakage; if fluid handled has penetrated the stator space, it has been removed.

- No special safety precautions are required for further handling.
- The following safety precautions are required for flushing fluids, fluid residues and disposal:

.....

We confirm that the above data and information are correct and complete and that dispatch is effected in accordance with the relevant legal provisions.

.....
 Place, date and signature

.....
 Address

.....
 Company stamp

²²⁾ Required field

Index

A

Applications 8
Automation 21

B

Bearings 22

C

Certificate of Decontamination 73
Commissioning/start-up 31
Configuration 22

D

Design 21
Direction of rotation 30
Dismantling 44
Disposal 13
Drive 21

E

Electrical connection 28
Event of damage 6
 Ordering spare parts 57
Explosion protection 27, 29, 40

F

Faults
 Causes and remedies 58
Fluid handled
 Density 37
Function 22

G

Grease lubrication
 Grease quality 42
 Intervals 42

I

Installation 21
 Installation on a foundation 24
Installation at site 23
Intended use 8

K

Key to safety symbols/markings 7

M

Maintenance 41
Mechanical seal 33

N

Name plate 20

O

Other applicable documents 6

P

Partly completed machinery 6
Permissible forces at the pump nozzles 26, 27
Piping 25
Preservation 12, 39
Product description 15

R

Reassembly 44
Return to supplier 14
Returning to service 39

S

Safety 8
Safety awareness 9
Scope of supply 22
Shaft seal 21
Shutdown 39
Spare part
 Ordering spare parts 57
Storage 12, 39

T

Tightening torques 56
Transport 11

W

Warnings 7
Warranty claims 6



KSB B.V.
Kalkovenweg 13
2401 LJ Alphen aan den Rijn (Netherlands)

1798.82/13-EN (01424629)