

# Dry-installed Volute Casing Pump

## Sewatec

50 / 60 Hz  
DIN / IEC Motors  
Bearing Brackets S01, S02, S03, S04

## Installation/Operating Manual



Mat. No.: 01104287

CE

KSB 

## **Legal information/Copyright**

Installation/Operating Manual Sewatec

Original operating manual

All rights reserved. The contents provided herein must neither be distributed, copied, reproduced, edited or processed for any other purpose, nor otherwise transmitted, published or made available to a third party without the manufacturer's express written consent.

Subject to technical modification without prior notice.

© KSB SE & Co. KGaA, Frankenthal 2023-02-17

## Contents

	<b>Glossary .....</b>	<b>6</b>
<b>1</b>	<b>General.....</b>	<b>7</b>
	1.1 Principles .....	7
	1.2 Installation of partly completed machinery.....	7
	1.3 Target group.....	7
	1.4 Other applicable documents.....	7
	1.5 Symbols .....	7
	1.6 Key to safety symbols/markings.....	8
<b>2</b>	<b>Safety .....</b>	<b>9</b>
	2.1 General.....	9
	2.2 Intended use .....	9
	2.2.1 Prevention of foreseeable misuse .....	10
	2.3 Personnel qualification and training.....	10
	2.4 Consequences and risks caused by non-compliance with this manual .....	10
	2.5 Safety awareness .....	11
	2.6 Safety information for the operator/user .....	11
	2.7 Safety information for maintenance, inspection and installation .....	11
	2.8 Unauthorised modes of operation .....	11
	2.9 Explosion protection .....	12
	2.9.1 Marking .....	12
<b>3</b>	<b>Transport/Storage/Disposal .....</b>	<b>13</b>
	3.1 Checking the condition upon delivery .....	13
	3.2 Transport.....	13
	3.3 Storage/preservation .....	14
	3.4 Return to supplier.....	15
	3.5 Disposal .....	15
<b>4</b>	<b>Description of the Pump (Set) .....</b>	<b>16</b>
	4.1 General description .....	16
	4.2 Product information as per Regulation No. 1907/2006 (REACH).....	16
	4.3 Designation.....	17
	4.4 Name plate.....	17
	4.5 Design details.....	17
	4.6 Design and function .....	18
	4.7 Noise characteristics .....	19
	4.8 Scope of supply.....	19
	4.9 Dimensions and weights .....	19
<b>5</b>	<b>Installation at Site .....</b>	<b>20</b>
	5.1 Safety regulations.....	20
	5.2 Checks to be carried out prior to installation.....	20
	5.3 Installing the pump set in a horizontal position .....	20
	5.4 Piping .....	22
	5.4.1 Connecting the piping .....	22
	5.4.2 Permissible forces and moments at the pump nozzles.....	23
	5.4.3 Vacuum balance line.....	28
	5.5 Auxiliary connections .....	28
	5.6 Checking the coupling alignment .....	29
	5.7 Checking the belt drive .....	32
	5.7.1 Checking the pulley alignment .....	32
	5.7.2 Tensioning the belts .....	32
	5.8 Aligning the pump and motor .....	33
	5.8.1 Motors with adjusting screw.....	33
	5.9 Checking the lubricants.....	34

5.10	Electrical connection .....	34
5.11	Checking the direction of rotation.....	35
5.12	Priming and venting the pump .....	36
5.13	Protective devices .....	36
5.14	Connecting the vibration sensor .....	36
5.15	Connecting temperature measuring devices.....	36
5.16	Warning and trip values.....	37
<b>6</b>	<b>Commissioning/Start-up/Shutdown .....</b>	<b>38</b>
6.1	Commissioning/Start-up.....	38
6.1.1	Prerequisites for commissioning/start-up .....	38
6.1.2	Start-up.....	38
6.1.3	Shutdown .....	39
6.2	Operating limits.....	39
6.2.1	Maximum operating pressure, maximum test pressure .....	40
6.2.2	Frequency of starts.....	41
6.2.3	Fluid handled .....	41
6.2.3.1	Temperature of the fluid handled.....	41
6.2.3.2	Density of the fluid handled .....	41
6.2.3.3	Abrasive fluids.....	42
6.3	Shutdown/storage/preservation .....	42
6.4	Returning to service .....	42
<b>7</b>	<b>Servicing/Maintenance .....</b>	<b>44</b>
7.1	Safety regulations.....	44
7.2	Servicing/inspection.....	45
7.2.1	Supervision of operation .....	45
7.2.2	Inspection work.....	46
7.2.2.1	Visual inspection through the inspection hole .....	46
7.2.3	Lubrication and lubricant change .....	47
7.2.3.1	Lubricating the rolling element bearings.....	47
7.2.3.2	Changing the lubricant of the mechanical seal .....	47
7.2.3.3	Lubricant quantity .....	49
7.2.3.4	Lubricant quality .....	50
7.3	Drainage/cleaning .....	50
7.4	Dismantling the pump set.....	50
7.4.1	General information/Safety regulations.....	50
7.4.2	Preparations for dismantling .....	51
7.4.3	Separating the pump from the piping .....	52
7.4.4	Removing the belt drive for installation type 3HZ .....	52
7.4.4.1	Using taper clamping bushes .....	53
7.4.4.2	Using pulleys to DIN 2211.....	53
7.4.5	Removing the back pull-out unit.....	54
7.4.6	Removing an impeller with tapered interference fit.....	54
7.4.7	Dismantling the mechanical seal .....	56
7.4.7.1	Dismantling the pump-end mechanical seal .....	56
7.4.7.2	Dismantling the motor-end mechanical seal .....	56
7.4.7.3	Removing the C022/025/11-4STQ double cartridge seal.....	57
7.4.7.4	Removing the C033/055M1-4STQ double cartridge seal .....	57
7.4.8	Removing shaft and rolling element bearings.....	58
7.4.9	Removing the wear plate (for D impeller only) .....	59
7.5	Reassembling the pump set.....	60
7.5.1	General information/Safety regulations.....	60
7.5.2	Re-installing the shaft and rolling element bearings .....	60
7.5.3	Installing the mechanical seal .....	61
7.5.3.1	Installing the bellows-type mechanical seal.....	62
7.5.3.2	Installing the C022/025M1-4STQ double cartridge seal.....	64
7.5.3.3	Installing the C033/055M1-4STQ double cartridge seal.....	66
7.5.4	Fitting the impeller .....	69
7.5.5	Installing the back pull-out unit.....	71

7.5.6	Leak test .....	72
7.5.7	Mounting the motor.....	73
7.5.8	Fitting the belt drive.....	73
7.5.8.1	Using taper clamping bushes .....	74
7.5.8.2	Using pulleys to DIN 2211.....	74
7.6	Tightening torques.....	75
7.6.1	Tightening torques for the pump set .....	75
7.7	Spare parts stock.....	75
7.7.1	Ordering spare parts.....	75
7.7.2	Recommended spare parts stock for 2 years' operation to DIN 24296.....	76
<b>8</b>	<b>Trouble-shooting.....</b>	<b>77</b>
<b>9</b>	<b>Related Documents .....</b>	<b>79</b>
9.1	Speed adjustment.....	79
9.2	Mass moments of inertia.....	79
9.3	General assembly drawings/exploded views with list of components .....	81
9.3.1	General assembly drawing – Sewatec with bearing brackets S01, S02, S03, S04 .....	81
9.3.2	Detail drawings .....	82
9.3.2.1	Impeller types.....	82
9.3.2.2	Inspection hole, bearing brackets S01 to S04.....	83
9.3.3	Sectional drawings of the mechanical seal.....	84
9.3.3.1	Drive-end mechanical seal.....	84
9.3.3.2	Pump-end mechanical seal .....	84
9.3.3.3	Cartridge seal C022/025M1-4STQ .....	85
9.3.3.4	Cartridge seal C033/055M1-4STQ .....	86
9.3.4	Exploded view: Sewatec with bearing brackets S01, S02, S03, S04.....	87
<b>10</b>	<b>EU Declaration of Conformity .....</b>	<b>89</b>
<b>11</b>	<b>Certificate of Decontamination.....</b>	<b>90</b>
	<b>Index .....</b>	<b>91</b>

## Glossary

### Back pull-out design

The complete back pull-out unit can be pulled out without having to remove the pump casing from the piping.

### Certificate of decontamination

A certificate of decontamination is enclosed by the customer when returning the product to the manufacturer to certify that the product has been properly drained to eliminate any environmental and health hazards arising from components in contact with the fluid handled.

### Discharge line

The pipeline which is connected to the discharge nozzle

### Hydraulic system

The part of the pump in which the kinetic energy is converted into pressure energy

### Pump

Machine without drive, additional components or accessories

### Pump set

Complete pump set consisting of pump, drive, additional components and accessories

### Suction lift line/suction head line

The pipeline which is connected to the suction nozzle

## 1 General

### 1.1 Principles

This operating manual is valid for the type series and variants indicated on the front cover.

The operating manual describes the proper and safe use of this equipment in all phases of operation.

The name plate indicates the type series and size, the main operating data, the order number and the order item number. The order number and order item number clearly identify the pump set and serve as identification for all further business processes.

In the event of damage, immediately contact your nearest KSB service facility to maintain the right to claim under warranty.

### 1.2 Installation of partly completed machinery

To install partly completed machinery supplied by KSB refer to the sub-sections under Servicing/Maintenance. (⇒ Section 7.5.5, Page 71)

### 1.3 Target group

This operating manual is aimed at the target group of trained and qualified specialist technical personnel. (⇒ Section 2.3, Page 10)

### 1.4 Other applicable documents

**Table 1:** Overview of other applicable documents

Document	Contents
Data sheet	Description of the technical data of the pump (set)
General arrangement drawing / outline drawing	Description of mating dimensions and installation dimensions for the pump (set), weights
Drawing of auxiliary connections	Description of auxiliary connections
Hydraulic characteristic curve	Characteristic curves showing head, NPSH required, efficiency and power input
General assembly drawing <sup>1)</sup>	Sectional drawing of the pump
Sub-supplier product literature <sup>1)</sup>	Operating manuals and other product literature describing accessories and integrated machinery components
Spare parts lists <sup>1)</sup>	Description of spare parts
Piping layout <sup>1)</sup>	Description of auxiliary piping
List of components <sup>1)</sup>	Description of all pump components
Assembly drawing <sup>1)</sup>	Sectional drawing of the installed shaft seal


For accessories and/or integrated machinery components, observe the relevant manufacturer's product literature.

### 1.5 Symbols

**Table 2:** Symbols used in this manual







Symbol	Description
✓	Conditions which need to be fulfilled before proceeding with the step-by-step instructions
▷	Safety instructions
⇨	Result of an action
⇨	Cross-references

<sup>1</sup> If included in agreed scope of supply

Symbol	Description
1. 2.	Step-by-step instructions
	Note Recommendations and important information on how to handle the product

### 1.6 Key to safety symbols/markings

Table 3: Definition of safety symbols/markings

Symbol	Description
 <b>DANGER</b>	<b>DANGER</b> This signal word indicates a high-risk hazard which, if not avoided, will result in death or serious injury.
 <b>WARNING</b>	<b>WARNING</b> This signal word indicates a medium-risk hazard which, if not avoided, could result in death or serious injury.
<b>CAUTION</b>	<b>CAUTION</b> This signal word indicates a hazard which, if not avoided, could result in damage to the machine and its functions.
	<b>Explosion protection</b> This symbol identifies information about avoiding explosions in potentially explosive atmospheres in accordance with EU Directive 2014/34/EU (ATEX).
	<b>General hazard</b> In conjunction with one of the signal words this symbol indicates a hazard which will or could result in death or serious injury.
	<b>Electrical hazard</b> In conjunction with one of the signal words this symbol indicates a hazard involving electrical voltage and identifies information about protection against electrical voltage.
	<b>Machine damage</b> In conjunction with the signal word CAUTION this symbol indicates a hazard for the machine and its functions.





## 2 Safety

All the information contained in this section refers to hazardous situations.






In addition to the present general safety information the action-related safety information given in the other sections must be observed.

### 2.1 General

- This operating manual contains general installation, operating and maintenance instructions that must be observed to ensure safe operation of the system and prevent personal injury and damage to property.
- Comply with all the safety instructions given in the individual sections of this operating manual.
- The operating manual must be read and understood by the responsible specialist personnel/operators prior to installation and commissioning.
- The contents of this operating manual must be available to the specialist personnel at the site at all times.
- Information and markings attached directly to the product must always be complied with and kept in a perfectly legible condition at all times. This applies to, for example:
  - Arrow indicating the direction of rotation
  - Markings for connections
  - Name plate
- The operator is responsible for ensuring compliance with all local regulations not taken into account.

### 2.2 Intended use

- The pump set must only be operated within the operating limits described in the other applicable documents.
- Only operate pump sets which are in perfect technical condition.
- Do not operate partially assembled pump sets.
- Only use the pump to handle the fluids described in the data sheet or product literature of the pump model.
- Never operate the system without the fluid to be handled.
- Observe the limits for continuous duty specified in the data sheet or product literature ( $Q_{\min}$  and  $Q_{\max}$ ) (to prevent damage such as shaft fracture, bearing failure, mechanical seal damage, etc).
- When untreated waste water is handled, the duty points in continuous operation lie within  $0.7$  to  $1.2 \times Q_{\text{BEP}}$  to minimise the risk of clogging/hardening.
- Avoid duty points for continuous operation at very low speeds and small flow rates ( $< 0.7 \times Q_{\text{BEP}}$ ).
- Observe the minimum flow rate and maximum flow rate indicated in the data sheet or product literature (to prevent overheating, mechanical seal damage, cavitation damage, bearing damage, etc).
- Do not throttle the flow rate on the suction side of the system (prevention of cavitation damage).
- Consult the manufacturer about any use or mode of operation not described in the data sheet or product literature.
- Only use the respective impeller types in combination with the fluids described below.

	Free-flow impeller (impeller type F/F-max)	<b>Suitable for the following fluids:</b> fluids containing solids and stringy material as well as fluids with entrapped air or entrapped gas
	Open, diagonal single-channel impeller (impeller type D)	<b>Suitable for the following fluids:</b> fluids containing solid substances and long fibres
	Open radial multi-vane impeller (impeller type D-max)	<b>Suitable for the following fluids:</b> fluids containing solid substances and long fibres
	Closed single-channel impeller (impeller type E/E-max)	<b>Suitable for the following fluids:</b> fluids containing solids and stringy material
	Closed multi-channel impeller (impeller type K/K-max)	<b>Suitable for the following fluids:</b> contaminated, solids-laden, non-gaseous fluids without stringy material

**2.2.1 Prevention of foreseeable misuse**

- Observe the minimum flow velocities required to fully open the swing check valves to prevent the reduction of pressure and risk of clogging. (Contact the manufacturer for the required minimum flow velocities/loss coefficients.)
- Never exceed the permissible application and operating limits specified in the data sheet or product literature regarding pressure, temperature, etc.
- Observe all safety information and instructions in this manual.

**2.3 Personnel qualification and training**

All personnel involved must be fully qualified to transport, install, operate, maintain and inspect the machinery this manual refers to.

The responsibilities, competence and supervision of all personnel involved in transport, installation, operation, maintenance and inspection must be clearly defined by the operator.

Deficits in knowledge must be rectified by means of training and instruction provided by sufficiently trained specialist personnel. If required, the operator can commission the manufacturer/supplier to train the personnel.

Training on the pump (set) must always be supervised by technical specialist personnel.

**2.4 Consequences and risks caused by non-compliance with this manual**

- Non-compliance with these operating instructions will lead to forfeiture of warranty cover and of any and all rights to claims for damages.
- Non-compliance can, for example, have the following consequences:
  - Hazards to persons due to electrical, thermal, mechanical and chemical effects and explosions
  - Failure of important product functions
  - Failure of prescribed maintenance and servicing practices
  - Hazard to the environment due to leakage of hazardous substances

### 2.5 Safety awareness

In addition to the safety information contained in this operating manual and the intended use, the following safety regulations shall be complied with:

- Accident prevention, health regulations and safety regulations
- Explosion protection regulations
- Safety regulations for handling hazardous substances
- Applicable standards, directives and laws

### 2.6 Safety information for the operator/user

- Fit protective equipment (e.g. contact guards) supplied by the operator for hot, cold or moving parts, and check that the equipment functions properly.
- Do not remove any protective equipment (e.g. contact guards) while the pump is in operation. The only exception is the guard of the packing chamber.
- Provide the personnel with protective equipment and make sure it is used.
- Contain leakages (e.g. at the shaft seal) of hazardous fluids handled (e.g. explosive, toxic, hot) so as to avoid any danger to persons and the environment. Adhere to all relevant laws.
- Eliminate all electrical hazards. (In this respect refer to the applicable national safety regulations and/or regulations issued by the local energy supply companies.)
- If stopping the pump does not increase potential risk, fit an emergency-stop control device in the immediate vicinity of the pump (set) during pump set installation.

### 2.7 Safety information for maintenance, inspection and installation

- Modifications or alterations of the pump (set) are only permitted with the manufacturer's prior consent.
- Use only original spare parts or parts/components authorised by the manufacturer. The use of other parts/components can invalidate any liability of the manufacturer for resulting damage.
- The operator ensures that maintenance, inspection and installation are performed by authorised, qualified specialist personnel who are thoroughly familiar with the manual.
- Only carry out work on the pump (set) during standstill of the pump.
- Only perform work on the pump set when it has been disconnected from the power supply (de-energised).
- The pump (set) must have cooled down to ambient temperature.
- Pump pressure must have been released and the pump must have been drained.
- When taking the pump set out of service always adhere to the procedure described in the manual.
- Decontaminate pumps which handle fluids posing a health hazard. (⇒ Section 7.3, Page 50)
- As soon as the work has been completed, re-install and re-activate any safety-relevant devices and protective devices. Before returning the product to service, observe all instructions on commissioning. (⇒ Section 6.1, Page 38)

### 2.8 Unauthorised modes of operation

Never operate the pump (set) outside the limits stated in the data sheet and in this operating manual.

The warranty relating to the operating reliability and safety of the pump (set) supplied is only valid if the equipment is used in accordance with its intended use.



## 2.9 Explosion protection

**Always observe the information on explosion protection given in this section when operating an explosion-proof pump set.**

Sections of the manual marked by the symbol opposite apply to explosion-proof pump sets also when temporarily operated outside potentially explosive atmospheres.

Pumps / pump sets must not be used in potentially explosive atmospheres unless marked as explosion-proof **and** identified as such in the data sheet.

Special conditions apply to the operation of explosion-proof pump sets in accordance with EU Directive *2014/34/EU (ATEX)*.

Especially adhere to the sections in this manual marked with the symbol opposite. The explosion-proof status of the pump is only assured if the pump is used in accordance with its intended use.

Never operate the product outside the limits stated in the data sheet and on the name plate.

Prevent impermissible modes of operation.

### 2.9.1 Marking

**Pump** The marking on the pump refers to the pump part only.

Example of such marking:

II 2 G Ex h IIB T5 -T1 Gb

Refer to the individual Temperature Limits table for the temperatures permitted for the individual pump variants.

The pump complies with the requirements of type of protection constructional safety "c" to ISO 80079-37.

**Shaft coupling** An EC manufacturer's declaration is required for the shaft coupling; the shaft coupling must be marked accordingly.

**Motor** The motor must be considered separately.

### 3 Transport/Storage/Disposal

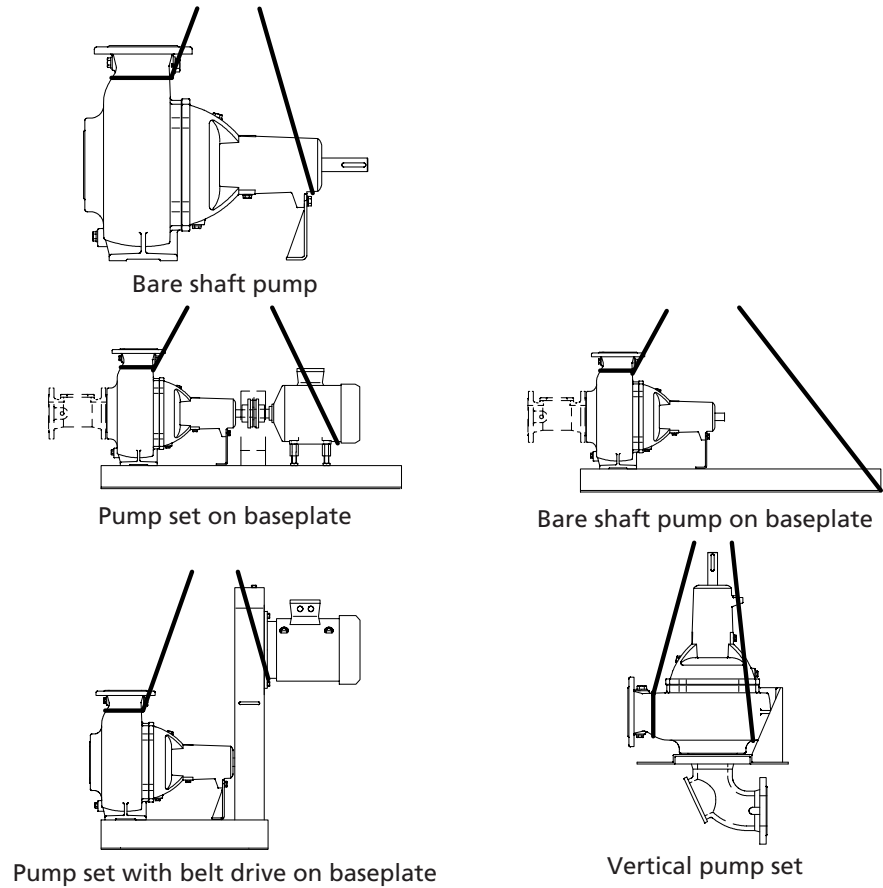
#### 3.1 Checking the condition upon delivery

1. On transfer of goods, check each packaging unit for damage.
2. In the event of in-transit damage, assess the exact damage, document it and notify KSB or the supplying dealer and the insurer about the damage in writing immediately.

#### 3.2 Transport

	<b>DANGER</b>
	<p><b>The pump (set) could slip out of the suspension arrangement</b>            Danger to life from falling parts!</p> <ul style="list-style-type: none"> <li>▷ Always transport the pump (set) in the specified position.</li> <li>▷ Never attach the suspension arrangement to the free shaft end or the motor eyebolt.</li> <li>▷ Observe the information about weights, centre of gravity and fastening points.</li> <li>▷ Observe the applicable local accident prevention regulations.</li> <li>▷ Use suitable, permitted lifting accessories, e.g. self-tightening lifting tongs.</li> </ul>
	<b>WARNING</b>
	<p><b>Uncontrolled lifting of the pump (set) or drive</b>            Risk of injury!</p> <ul style="list-style-type: none"> <li>▷ Maintain adequate safety distance during lifting operations (load may swing when being lifted).</li> </ul>
	<b>WARNING</b>
	<p><b>Placing the pump / pump set / packaging unit on unsecured and uneven surfaces</b>            Personal injury and damage to property!</p> <ul style="list-style-type: none"> <li>▷ Only place the pump / pump set / packaging unit on a surface of sufficient load-carrying capacity.</li> <li>▷ Use appropriate means to secure the pump / pump set / packaging unit against tilting or tipping over.</li> </ul>

To transport the pump/pump set suspend it from the lifting tackle as shown.



### 3.3 Storage/preservation

If commissioning is to take place some time after delivery, we recommend that the following measures be taken:


	<p><b>CAUTION</b></p> <p><b>Damage during storage due to humidity, dirt or vermin</b> Corrosion/contamination of pump (set)!</p> <ul style="list-style-type: none"> <li>▷ For outdoor storage cover the pump (set) and accessories with waterproof material and protect against condensation.</li> </ul>
	<p><b>CAUTION</b></p> <p><b>Wet, contaminated or damaged openings and connections</b> Leakage or damage to the pump!</p> <ul style="list-style-type: none"> <li>▷ Clean and cover pump openings and connections as required prior to putting the pump into storage.</li> </ul>

**Table 4:** Ambient conditions for storage

Ambient condition	Value
Relative humidity	5 % to 85 % (non-condensing)
Ambient temperature	-20 °C to +70 °C

- Store the pump set in dry, vibration-free conditions and in its original packaging. (⇒ Section 6.3, Page 42)
- 1. Spray-coat the inside wall of the pump casing and, in particular, the impeller clearance areas with a preservative.
- 2. Spray preservative through the suction nozzle and discharge nozzle. It is advisable to then close the pump nozzles (e.g. with plastic caps or similar).

2580.815/14-EN


	<b>NOTE</b>
	Observe the manufacturer's instructions for application/removal of the preservative.

### 3.4 Return to supplier

1. Drain the pump as per operating instructions. (⇒ Section 7.3, Page 50)
2. Flush and clean the pump, particularly if it has been used for handling noxious, explosive, hot or other hazardous fluids.
3. If the pump has handled fluids whose residues could lead to corrosion damage in the presence of atmospheric humidity or could ignite upon contact with oxygen, the pump must also be neutralised, and anhydrous inert gas must be blown through the pump to ensure drying.
4. Always complete and enclose a certificate of decontamination when returning the pump.  
Indicate any safety measures and decontamination measures taken.  
(⇒ Section 11, Page 90)

	<b>NOTE</b>
	If required, a blank certificate of decontamination can be downloaded from the following web site: <a href="http://www.ksb.com/certificate_of_decontamination">www.ksb.com/certificate_of_decontamination</a>

### 3.5 Disposal

	<b>⚠ WARNING</b>
	<p><b>Fluids handled, consumables and supplies which are hot and/or pose a health hazard</b></p> <p>Hazard to persons and the environment!</p> <ul style="list-style-type: none"> <li>▷ Collect and properly dispose of flushing fluid and any fluid residues.</li> <li>▷ Wear safety clothing and a protective mask if required.</li> <li>▷ Observe all legal regulations on the disposal of fluids posing a health hazard.</li> </ul>

1. Dismantle the pump (set).  
Collect greases and other lubricants during dismantling.
2. Separate and sort the pump materials, e.g. by:
  - Metals
  - Plastics
  - Electronic waste
  - Greases and other lubricants
3. Dispose of materials in accordance with local regulations or in another controlled manner.

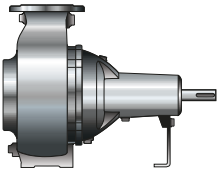
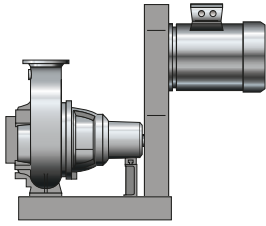
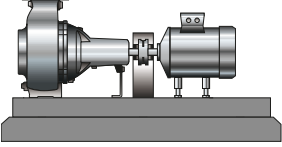
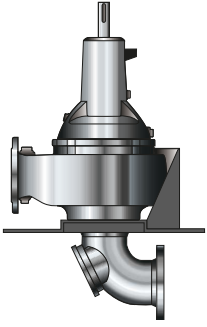
## 4 Description of the Pump (Set)

### 4.1 General description

Pump for handling untreated sewage and all types of waste water.

- Volute casing pump with single-vane impeller, multi-vane impeller, free-flow impeller or open diagonal single-vane impeller.
- Electric motor connected to the pump via a coupling, belt drive or universal-joint shaft

**Table 5:** Installation types

Installation type	Drawing	Description
Figure 0		Bare shaft pump
Figure 3HZ		Pump set with baseplate, belt drive, belt guard and drive
Figure 3EN Figure 3ENH		Pump set with directly coupled drive, baseplate, coupling (also with coupling spacer), coupling guard and height adjustment of the motor
Figure V		Pump with bare shaft at the drive end, sole plate and suction elbow

### 4.2 Product information as per Regulation No. 1907/2006 (REACH)

For information as per European chemicals regulation (EC) No. 1907/2006 (REACH) see <https://www.ksb.com/en-global/company/corporate-responsibility/reach>.



### 4.3 Designation

Example: Sewatec F 100-250G V

Table 6: Designation key

Code	Description
Sewatec	Type series
F	Impeller type
100	Nominal discharge nozzle diameter [mm]
250	Nominal impeller diameter [mm]
G	Material variant
V	Installation type

### 4.4 Name plate

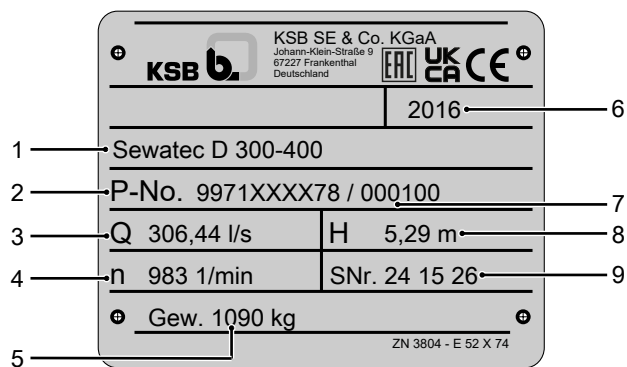


Fig. 1: Name plate (example)

1	Designation of the pump set	2	Order number
3	Flow rate	4	Speed
5	Weight of bare-shaft pump	6	Year of supply
7	Order item number	8	Head
9	Serial number		

### 4.5 Design details

#### Design

- Volute casing pump
- Back pull-out design
- Single-stage
- Various, application-oriented installation types (⇒ Section 4.1, Page 16)

#### Shaft seal

- Two bi-directional mechanical seals in tandem arrangement, with liquid reservoir

#### Impeller type

- Various application-oriented impeller types (⇒ Section 2.2, Page 9)

#### Bearings

- Grease-packed, zero-maintenance deep groove ball bearings (sealed for life) on pump and drive end

4.6 Design and function

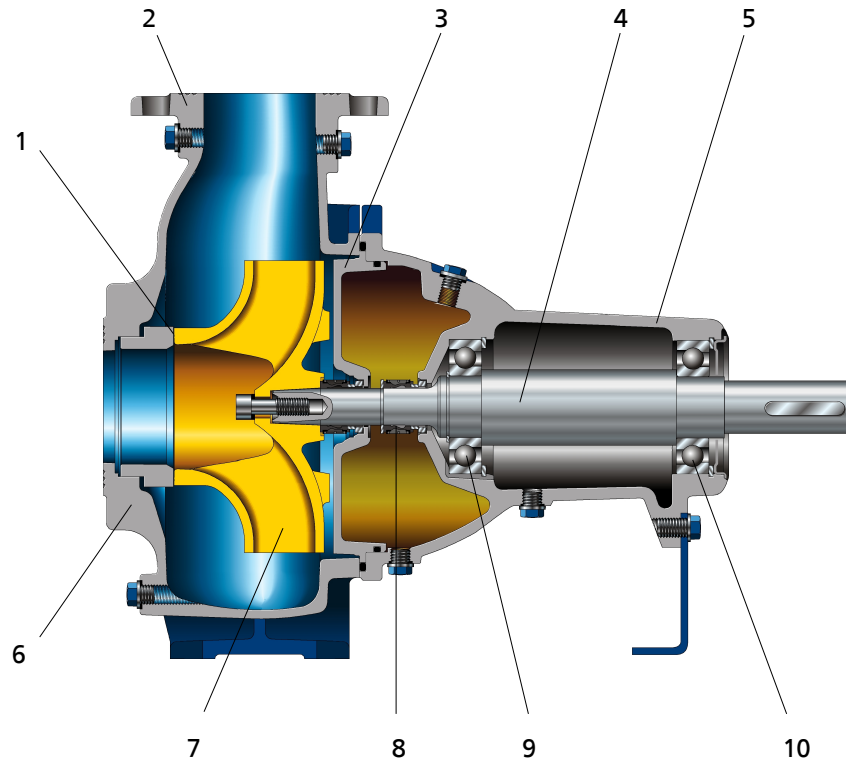


Fig. 2: Sectional drawing with K impeller

1	Clearance gap	2	Discharge nozzle
3	Discharge cover	4	Shaft
5	Bearing bracket	6	Suction nozzle
7	Impeller	8	Shaft seal
9	Rolling element bearing	10	Rolling element bearing

**Design** The pump is designed with an axial fluid inlet and a radial or tangential outlet. The hydraulic system runs in its own bearings and is connected to the motor by a shaft coupling or belt drive.

**Function** The fluid enters the pump axially via the suction nozzle (6) and is accelerated outward by the rotating impeller (7). In the flow passage of the pump casing the kinetic energy of the fluid is converted into pressure energy. The fluid is pumped to the discharge nozzle (2), where it leaves the pump. The clearance gap (1) prevents any fluid from flowing back from the casing to the suction nozzle. At the rear side of the impeller, the shaft (4) enters the casing via the casing cover (3). The shaft passage through the cover is sealed to atmosphere with a shaft seal (8). The shaft runs in rolling element bearings (9 and 10), which are supported by a bearing bracket (5) linked with the pump casing and/or casing cover.

**Sealing** The pump is sealed by two bi-directional mechanical seals in tandem arrangement. A lubricant reservoir in-between the seals ensures cooling and lubrication of the mechanical seals.

### 4.7 Noise characteristics

Table 7: Surface sound pressure level  $L_{pA}^{2)}$

Rated power input $P_N$	Pump			Pump set		
	2900 rpm	1450 rpm	960 / 760 rpm	2900 rpm	1450 rpm	960 / 760 rpm
[kW]	[dB]	[dB]	[dB]	[dB]	[dB]	[dB]
1,5	53,5	52,0	51,0	62,5	56,5	55,0
2,2	55,0	53,0	52,0	65,0	58,5	57,5
3,0	56,5	55,0	53,5	67,0	60,5	59,0
4,0	58,0	57,0	55,0	68,5	62,0	60,5
5,5	59,5	57,5	57,0	70,0	63,5	63,0
7,5	61,0	58,5	57,5	71,0	65,0	63,5
11,0	62,5	60,5	59,5	72,5	67,0	65,5
15,0	64,0	61,5	60,5	73,5	68,0	66,5
18,5	64,5	62,5	61,5	74,0	68,5	67,5
22,0	65,5	63,5	62,5	74,5	69,0	68,0
30,0	67,0	65,0	63,5	75,0	70,5	69,0
37,0	68,0	65,5	64,5	76,0	71,0	69,5

	<b>NOTE</b>
	For belt-driven pump sets add 2 dB.

### 4.8 Scope of supply

Depending on the model, the following items are included in the scope of supply:

- Pump
- Drive
- Baseplate or soleplate
- Coupling
- Coupling guard
- Belt drive and belt guard
- Suction-side flanged spacer with inspection hole<sup>3)</sup> (optional)
- Universal-joint shaft

### 4.9 Dimensions and weights

For dimensions and weights please refer to the data sheet of the pump (set).

- Pump weight: See name plate of the pump.
- Motor weight: See motor product literature.
- Weight of the shipping unit base frame with pump: See weight indicated on the base frame.
- Weight of the shipping unit base frame with pump and motor: See weight indicated on the base frame.

	<b>NOTE</b>
	Some individual components weigh more than 25 kg. Check the indicated weights. (⇒ Section 1.4, Page 7)

<sup>2</sup> Measured at a distance of 1 m from the pump outline (as per DIN 45635 Parts 1 and 24)

<sup>3</sup> For nominal discharge nozzle diameter  $\geq$  DN 100

## 5 Installation at Site

### 5.1 Safety regulations

	<p><b>⚠ DANGER</b></p> <p><b>Excessive temperatures in the shaft seal area</b> Explosion hazard!</p> <ul style="list-style-type: none"> <li>▷ Never operate a pump (set) with gland packing in potentially explosive atmospheres.</li> </ul>
	<p><b>NOTE</b></p> <p>Operating pump sets with gland packings in combination with a frequency inverter / variable speed system is not recommended.</p>

### 5.2 Checks to be carried out prior to installation

#### Place of installation

	<p><b>⚠ WARNING</b></p> <p><b>Installation on a mounting surface which is unsecured and cannot support the load</b> Personal injury and damage to property!</p> <ul style="list-style-type: none"> <li>▷ Use a concrete of compressive strength class C12/15 which meets the requirements of exposure class XC1 to EN 206.</li> <li>▷ The mounting surface must be set, even, and level.</li> <li>▷ Observe the weights indicated.</li> </ul>
--	---

1. Check the structural requirements.  
All structural work required must have been prepared in accordance with the dimensions stated in the outline drawing/general arrangement drawing.

### 5.3 Installing the pump set in a horizontal position

	<p><b>⚠ DANGER</b></p> <p><b>Electrostatic charging</b> Explosion hazard! Damage to the pump set!</p> <ul style="list-style-type: none"> <li>▷ Connect the potential equalisation conductor to the earthing terminal provided.</li> <li>▷ Make sure that the connection between pump and baseplate is electrically conductive.</li> <li>▷ Screws, bolts, nuts and shims must not be coated or the coating must be removed.</li> <li>▷ Provide potential equalisation between the pump set and the foundation.</li> </ul>
--	--

For installation types 3E and 3H

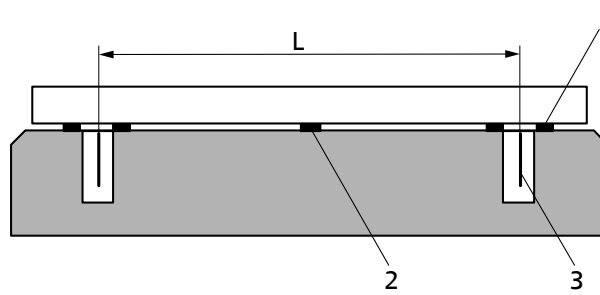


Fig. 3: Installation on a foundation with chemical anchors

L	Anchor-to-anchor distance	1	Shim
2	Shim if (L) > 800 mm	3	Chemical anchor

- ✓ The foundation has the required strength and characteristics.
  - ✓ The foundation has been prepared in accordance with the dimensions given in the outline drawing/general arrangement drawing.
1. Position the pump set on the foundation and level it with the help of a spirit level placed on the shaft and discharge nozzle.  
Permissible deviation 0.2 mm/m.
  2. Use shims (2) for height compensation, if necessary.  
Always fit shims, if any, immediately to the left and right of the chemical anchors (4) between the baseplate/foundation frame and the foundation.  
For a bolt-to-bolt distance (L) ≥ 800 mm fit additional shims (2) halfway between the adjoining holes.  
All shims must lie perfectly flush.
  3. Drill the holes as specified in the table "Chemical anchor bolt dimensions". Then clean the holes.

	<p><b>! WARNING</b></p>
	<p><b>Improper handling of mortar cartridge</b> Skin sensitisation and/or irritation!</p> <p>▷ Wear suitable protective clothing.</p>

4. Insert the mortar cartridges into the drilled holes.  
**Observe the curing times of the mortar cartridges!**
5. Insert threaded rods into the corresponding drilled holes with an electric tool (e.g. impact drill, hammer drill).
6. After the curing time (see table), tighten the chemical anchors (4) evenly and tightly.
7. Grout the baseplate using low-shrinkage concrete.

Chemical anchor dimensions

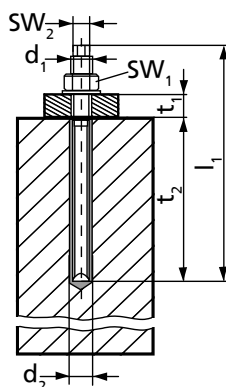


Fig. 4: Dimensions

**Table 8:** Chemical anchor dimensions

Size ( $d_1 \times l_1$ )	$d_2$	$t_1$	$t_2$	$SW_1^{4)}$	$SW_2^{4)}$	$M_{d1}$
	[mm]					[Nm]
M10 × 130	12	22	90	17	6	20
M12 × 160	14	25	110	19	8	40
M16 × 190	18	35	125	24	12	60
M20 × 260	25	65	170	30	14	120
M24 × 300 <sup>5)</sup>	28	65	210	36	17	180
M30 × 380 <sup>5)</sup>	35	65	280	46	-	400

#### 5.4 Piping

	<b>NOTE</b>
	When installing pumps in piping systems make sure to avoid any resonances at the usual excitation frequencies (e.g. 1x or 2x rotational frequency or rotational noise) in the connected piping and in the foundation. See DIN ISO 10816-3.

##### 5.4.1 Connecting the piping

	<b>⚠ DANGER</b>
	<p><b>Impermissible loads acting on the pump nozzles</b></p> <p>Danger to life from leakage of hot, toxic, corrosive or flammable fluids!</p> <ul style="list-style-type: none"> <li>▷ Do not use the pump as an anchorage point for the piping.</li> <li>▷ Anchor the pipelines in close proximity to the pump and connect them properly without transmitting any stresses or strains.</li> <li>▷ Observe the permissible forces and moments at the pump nozzles.</li> <li>▷ Take appropriate measures to compensate for thermal expansion of the piping.</li> </ul>

<sup>4</sup> SW = Width across flats

<sup>5</sup> Mounting accessories of the respective manufacturer are required.

	<b>NOTE</b>
	<p>Installing check and shut-off elements in the system is recommended, depending on the type of plant and pump. However, such elements must not obstruct proper drainage or hinder disassembly of the pump.</p>

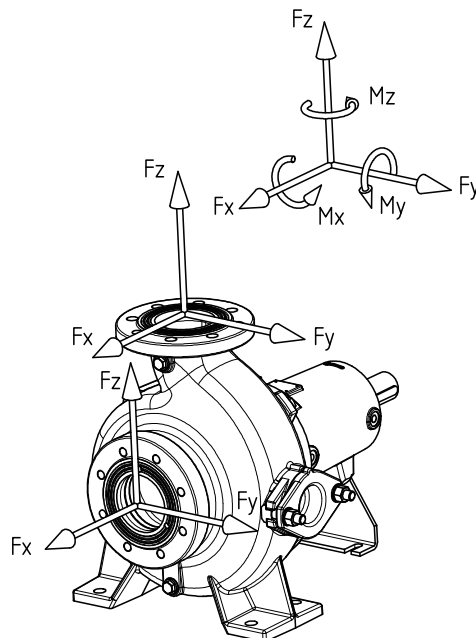
- ✓ The suction lift line has been laid with a rising slope, the suction head line with a downward slope towards the pump.
- ✓ A flow stabilisation section having a length equivalent to at least five times the diameter of the suction flange has been provided upstream of the suction flange.
- ✓ The nominal sizes of the pipelines are equal to or greater than the nominal sizes of the pump nozzles.
- ✓ To prevent excessive pressure losses, adapters to larger nominal diameters are designed with a diffuser angle of approx. 8°.
- ✓ The pipelines have been anchored in close proximity to the pump and connected without transmitting any stresses or strains.
  1. Before installation in the piping, remove the flange covers on the suction nozzle and the discharge nozzle.
  2. Connect the pump nozzles to the piping.

	<b>CAUTION</b>
	<p><b>Pumps connected with unbraced expansion joints</b> Machine damage by impermissible nozzle loads!</p> <p>▶ Never connect the pump with unbraced expansion joints.</p>

3. If the owner / operator supplies an expansion joint, it has to be braced with external tie rods to prevent impermissible nozzle loads.

### 5.4.2 Permissible forces and moments at the pump nozzles

#### Horizontal installation



**Fig. 5:** Forces and moments at the pump nozzles for horizontal installation, bare-shaft pump (Figure 0)

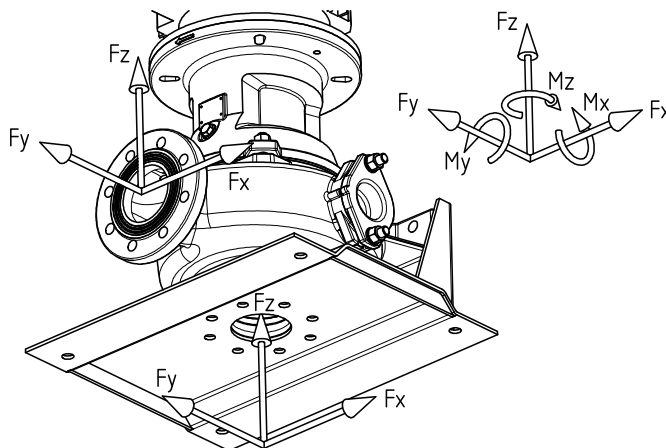
The loads are taken from ISO 5199. The values are applicable to each of the pump nozzles, taking into account the markings for the three axes of the respective flange.





Size	Impeller type	Flanges		Forces at suction nozzle				Moments at suction nozzle				Forces at discharge nozzle				Moments at discharge nozzle			
		DN1	DN2	Fy	Fz	Fx	ΣF	My	Mz	Mx	ΣM	Fy	Fz	Fx	ΣF	My	Mz	Mx	ΣM
				[N]				[Nm]				[N]				[Nm]			
150-401	E	150	150	1600	1400	1750	2750	600	700	900	1300	1400	1750	1600	2750	600	700	900	1300
150-401	F	150	150	1600	1400	1750	2750	600	700	900	1300	1400	1750	1600	2750	600	700	900	1300
150-403	K	200	150	2100	1900	2350	3650	800	950	1150	1700	1400	1750	1600	2750	600	700	900	1300
150-403	D	200	150	2100	1900	2350	3650	800	950	1150	1700	1400	1750	1600	2750	600	700	900	1300
200-315	K	200	200	2100	1900	2350	3650	800	950	1150	1700	1900	2350	2100	3650	800	950	1150	1700
200-315	D	200	200	2100	1900	2350	3650	800	950	1150	1700	1900	2350	2100	3650	800	950	1150	1700
200-316	K	200	200	2100	1900	2350	3650	800	950	1150	1700	1900	2350	2100	3650	800	950	1150	1700
200-317	K	200	200	2100	1900	2350	3650	800	950	1150	1700	1900	2350	2100	3650	800	950	1150	1700
200-318	K	200	200	2100	1900	2350	3650	800	950	1150	1700	1900	2350	2100	3650	800	950	1150	1700
200-401	E	200	200	2100	1900	2350	3650	800	950	1150	1700	1900	2350	2100	3650	800	950	1150	1700
200-402	K	200	200	2100	1900	2350	3650	800	950	1150	1700	1900	2350	2100	3650	800	950	1150	1700
200-402	D	250	200	2600	2400	2950	4550	1100	1300	1550	2300	1900	2350	2100	3650	800	950	1150	1700
200-403	K	200	200	2100	1900	2350	3650	800	950	1150	1700	1900	2350	2100	3650	800	950	1150	1700
200-405	D	250	200	2600	2400	2950	4550	1100	1300	1550	2300	1900	2350	2100	3650	800	950	1150	1700
250-401	K	250	250	2600	2400	2950	4550	1100	1300	1550	2300	2400	2950	2600	4550	1100	1300	1550	2300
250-402	D	250	250	2600	2400	2950	4550	1100	1300	1550	2300	2400	2950	2600	4550	1100	1300	1550	2300
250-403	K	250	250	2600	2400	2950	4550	1100	1300	1550	2300	2400	2950	2600	4550	1100	1300	1550	2300
300-400	K	300	300	3150	2800	3500	5500	1500	1750	2100	3100	2800	3500	3150	5500	1500	1750	2100	3100
300-401	K	300	300	3150	2800	3500	5500	1500	1750	2100	3100	2800	3500	3150	5500	1500	1750	2100	3100
300-402	D	300	300	3150	2800	3500	5500	1500	1750	2100	3100	2800	3500	3150	5500	1500	1750	2100	3100

Vertical installation



**Fig. 6:** Forces and moments at the pump nozzles, vertical installation, with soleplate  
 The loads are taken from ISO 5199. The values are applicable to each of the pump nozzles, taking into account the markings for the three axes of the respective flange.  
 The data on forces and moments apply to static piping loads only. If the limits are exceeded, they must be checked and verified.  
 If a computerised strength analysis is required, values are available on request only.  
 The values are only applicable if the pump is installed on a completely grouted baseplate and bolted to a rigid and level foundation.

**Table 10:** Forces and moments at the pump nozzles, vertical installation, with soleplate

Size	Impeller type	Flanges		Forces at suction nozzle				Moments at suction nozzle				Forces at discharge nozzle				Moments at discharge nozzle			
		DN1	DN2	Fy	Fz	Fx	ΣF	My	Mz	Mx	ΣM	Fy	Fz	Fx	ΣF	My	Mz	Mx	ΣM
				[N]				[Nm]				[N]				[Nm]			
50-215	F	65	50	600	750	650	1150	400	400	550	750	600	500	550	900	350	400	500	700
50-216	F	65	50	600	750	650	1150	400	400	550	750	600	500	550	900	350	400	500	700
50-250	K	65	50	600	750	650	1150	400	400	550	750	600	500	550	900	350	400	500	700
50-251	K	65	50	600	750	650	1150	400	400	550	750	600	500	550	900	350	400	500	700
65-215	F	80	65	700	900	800	1400	400	450	600	800	750	600	650	1150	400	400	550	750

2580.815/14-EN

Size	Impeller type	Flanges		Forces at suction nozzle				Moments at suction nozzle				Forces at discharge nozzle				Moments at discharge nozzle			
		DN1	DN2	Fy	Fz	Fx	ΣF	My	Mz	Mx	ΣM	Fy	Fz	Fx	ΣF	My	Mz	Mx	ΣM
				[N]				[Nm]				[N]				[Nm]			
65-216	E	80	65	700	900	800	1400	400	450	600	800	750	600	650	1150	400	400	550	750
65-217	F	80	65	700	900	800	1400	400	450	600	800	750	600	650	1150	400	400	550	750
65-250	K	80	65	700	900	800	1400	400	450	600	800	750	600	650	1150	400	400	550	750
65-252	K	80	65	700	900	800	1400	400	450	600	800	750	600	650	1150	400	400	550	750
80-215	F	100	80	950	1200	1050	1850	450	500	600	900	900	700	800	1400	400	450	600	800
80-216	F	100	80	950	1200	1050	1850	450	500	600	900	900	700	800	1400	400	450	600	800
80-216	E	100	80	950	1200	1050	1850	450	500	600	900	900	700	800	1400	400	450	600	800
80-217	F	100	80	950	1200	1050	1850	450	500	600	900	900	700	800	1400	400	450	600	800
80-250	K	100	80	950	1200	1050	1850	450	500	600	900	900	700	800	1400	400	450	600	800
80-252	F	100	80	950	1200	1050	1850	450	500	600	900	900	700	800	1400	400	450	600	800
80-253	F	100	80	950	1200	1050	1850	450	500	600	900	900	700	800	1400	400	450	600	800
80-253	E	100	80	950	1200	1050	1850	450	500	600	900	900	700	800	1400	400	450	600	800
80-315	K	100	80	950	1200	1050	1850	450	500	600	900	900	700	800	1400	400	450	600	800
80-315	D	100	80	950	1200	1050	1850	450	500	600	900	900	700	800	1400	400	450	600	800
80-316	D	125	80	1100	1400	1250	2150	550	650	750	1050	900	700	800	1400	400	450	600	800
80-317	F	100	80	950	1200	1050	1850	450	500	600	900	900	700	800	1400	400	450	600	800
80-317	D	100	80	950	1200	1050	1850	450	500	600	900	900	700	800	1400	400	450	600	800
100-215	F	100	100	950	1200	1050	1850	450	500	600	900	1200	950	1050	1850	450	500	600	900
100-251	F	100	100	950	1200	1050	1850	450	500	600	900	1200	950	1050	1850	450	500	600	900
100-252	F	100	100	950	1200	1050	1850	450	500	600	900	1200	950	1050	1850	450	500	600	900
100-253	F	100	100	950	1200	1050	1850	450	500	600	900	1200	950	1050	1850	450	500	600	900
100-253	K	100	100	950	1200	1050	1850	450	500	600	900	1200	950	1050	1850	450	500	600	900
100-253	D	150	100	1400	1750	1600	2750	600	700	900	1300	1200	950	1050	1850	450	500	600	900
100-254	F, K	100	100	950	1200	1050	1850	450	500	600	900	1200	950	1050	1850	450	500	600	900
100-316	F, K	150	100	1400	1750	1600	2750	600	700	900	1300	1200	950	1050	1850	450	500	600	900
100-316	D	150	100	1400	1750	1600	2750	600	700	900	1300	1200	950	1050	1850	450	500	600	900
150-253	D	150	150	1400	1750	1600	2750	600	700	900	1300	1750	1400	1600	2750	600	700	900	1300
150-315	F, K	150	150	1400	1750	1600	2750	600	700	900	1300	1750	1400	1600	2750	600	700	900	1300
150-315	D	150	150	1400	1750	1600	2750	600	700	900	1300	1750	1400	1600	2750	600	700	900	1300
150-317	D	200	150	1900	2350	2100	3650	800	950	1150	1700	1750	1400	1600	2750	600	700	900	1300
150-317	K	150	150	1400	1750	1600	2750	600	700	900	1300	1750	1400	1600	2750	600	700	900	1300
200-315	K	200	200	1900	2350	2100	3650	800	950	1150	1700	2350	1900	2100	3650	800	950	1150	1700
200-315	D	200	200	1900	2350	2100	3650	800	950	1150	1700	2350	1900	2100	3650	800	950	1150	1700
200-316	K	200	200	1900	2350	2100	3650	800	950	1150	1700	2350	1900	2100	3650	800	950	1150	1700
200-317	K	200	200	1900	2350	2100	3650	800	950	1150	1700	2350	1900	2100	3650	800	950	1150	1700
200-318	K	200	200	1900	2350	2100	3650	800	950	1150	1700	2350	1900	2100	3650	800	950	1150	1700

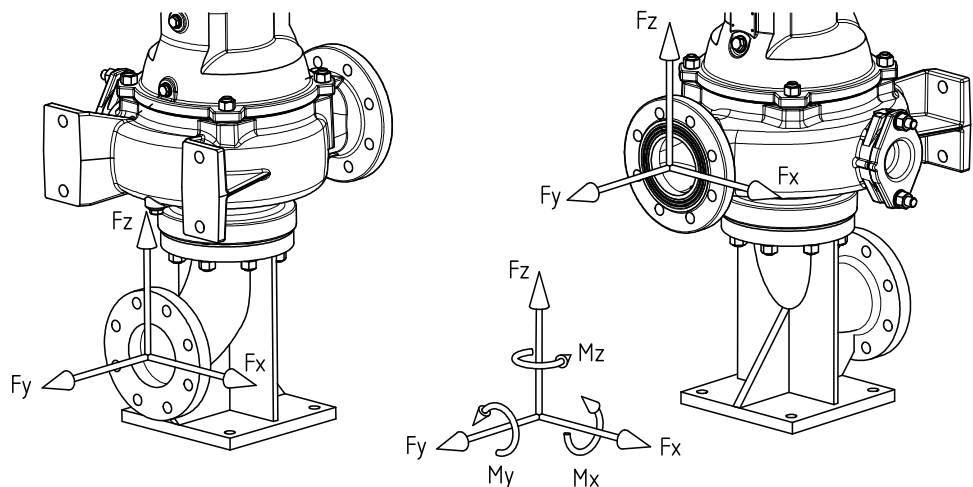


Fig. 7: Forces and moments at the pump nozzles, vertical installation, with suction elbow


2580.815/14-EN

The loads are taken from ISO 5199. The values are applicable to each of the pump nozzles, taking into account the markings for the three axes of the respective flange. The data on forces and moments apply to static piping loads only. If the limits are exceeded, they must be checked and verified. If a computerised strength analysis is required, values are available on request only. The values are only applicable if the pump is installed on a completely grouted baseplate and bolted to a rigid and level foundation.

**Table 11:** Forces and moments at the pump nozzles, vertical installation, with suction elbow

Size	Impeller type	Flanges		Forces at suction nozzle				Moments at suction nozzle				Forces at discharge nozzle				Moments at discharge nozzle			
		DN1	DN2	Fy	Fz	Fx	ΣF	My	Mz	Mx	ΣM	Fy	Fz	Fx	ΣF	My	Mz	Mx	ΣM
		[N]				[Nm]				[N]				[Nm]					
50-215	F	65	50	1700	2100	2101	3300	1100	1200	1500	2200	600	500	550	900	350	400	500	700
50-216	F	65	50	1700	2100	1850	3300	1100	1200	1500	2200	600	500	550	900	350	400	500	700
50-250	K	65	50	1700	2100	1850	3300	1100	1200	1500	2200	600	500	550	900	350	400	500	700
50-251	K	65	50	1700	2100	1850	3300	1100	1200	1500	2200	600	500	550	900	350	400	500	700
65-215	F	80	65	2050	2500	2250	3950	1150	1300	1600	2350	750	600	650	1150	400	400	550	750
65-216	E	80	65	2050	2500	2250	3950	1150	1300	1600	2350	750	600	650	1150	400	400	550	750
65-217	F	80	65	2050	2500	2250	3950	1150	1300	1600	2350	750	600	650	1150	400	400	550	750
65-250	K	80	65	2050	2500	2250	3950	1150	1300	1600	2350	750	600	650	1150	400	400	550	750
65-252	K	80	65	2050	2500	2250	3950	1150	1300	1600	2350	750	600	650	1150	400	400	550	750
80-215	F	100	80	2700	3350	3000	5250	1250	1450	1750	2600	900	700	800	1400	400	450	600	800
80-216	F	100	80	2700	3350	3000	5250	1250	1450	1750	2600	900	700	800	1400	400	450	600	800
80-216	E	100	80	2700	3350	3000	5250	1250	1450	1750	2600	900	700	800	1400	400	450	600	800
80-217	F	100	80	2700	3350	3000	5250	1250	1450	1750	2600	900	700	800	1400	400	450	600	800
80-250	K	100	80	2700	3350	3000	5250	1250	1450	1750	2600	900	700	800	1400	400	450	600	800
80-252	F	100	80	2700	3350	3000	5250	1250	1450	1750	2600	900	700	800	1400	400	450	600	800
80-253	F	100	80	2700	3350	3000	5250	1250	1450	1750	2600	900	700	800	1400	400	450	600	800
80-253	E	100	80	2700	3350	3000	5250	1250	1450	1750	2600	900	700	800	1400	400	450	600	800
80-315	K	100	80	2700	3350	3000	5250	1250	1450	1750	2600	900	700	800	1400	400	450	600	800
80-315	D	100	80	2700	3350	3000	5250	1250	1450	1750	2600	900	700	800	1400	400	450	600	800
80-316	D	125	80	3200	3950	3550	6200	1500	1900	2100	3050	900	700	800	1400	400	450	600	800
80-317	F	100	80	2700	3350	3000	5250	1250	1450	1750	2600	900	700	800	1400	400	450	600	800
80-317	D	100	80	2700	3350	3000	5250	1250	1450	1750	2600	900	700	800	1400	400	450	600	800
100-215	F	100	100	2700	3350	3000	5250	1250	1450	1750	2600	1200	950	1050	1850	450	500	600	900
100-251	F	100	100	2700	3350	3000	5250	1250	1450	1750	2600	1200	950	1050	1850	450	500	600	900
100-252	F	100	100	2700	3350	3000	5250	1250	1450	1750	2600	1200	950	1050	1850	450	500	600	900
100-253	F	100	100	2700	3350	3000	5250	1250	1450	1750	2600	1200	950	1050	1850	450	500	600	900
100-253	K	100	100	2700	3350	3000	5250	1250	1450	1750	2600	1200	950	1050	1850	450	500	600	900
100-253	D	150	100	4050	5000	4500	7850	1750	2050	2500	3650	1200	950	1050	1850	450	500	600	900
100-254	F, K	100	100	4050	5000	4500	7850	1750	2050	2500	3650	1200	950	1050	1850	450	500	600	900
100-316	F, K	150	100	4050	5000	4500	7850	1750	2050	2500	3650	1200	950	1050	1850	450	500	600	900
100-316	D	150	100	4050	5000	4500	7850	1750	2050	2500	3650	1200	950	1050	1850	450	500	600	900
150-253	D	150	150	4050	5000	4500	7850	1750	2050	2500	3650	1750	1400	1600	2750	600	700	900	1300
150-315	F	150	150	4050	5000	4500	7850	1750	2050	2500	3650	1750	1400	1600	2750	600	700	900	1300
150-315	D	150	150	4050	5000	4500	7850	1750	2050	2500	3650	1750	1400	1600	2750	600	700	900	1300
150-317	D	200	150	5400	6700	6000	10450	2300	2650	3250	4800	1750	1400	1600	2750	600	700	900	1300
150-317	K	150	150	4050	5000	4500	7850	1750	2050	2500	3650	1750	1400	1600	2750	600	700	900	1300
200-315	K	200	200	5400	6700	6000	10450	2300	2650	3250	4800	2350	1900	2100	3650	800	950	1150	1700
200-315	D	200	200	5400	6700	6000	10450	2300	2650	3250	4800	2350	1900	2100	3650	800	950	1150	1700
200-316	K	200	200	5400	6700	6000	10450	2300	2650	3250	4800	2350	1900	2100	3650	800	950	1150	1700
200-317	K	200	200	5400	6700	6000	10450	2300	2650	3250	4800	2350	1900	2100	3650	800	950	1150	1700
200-318	K	200	200	5400	6700	6000	10450	2300	2650	3250	4800	2350	1900	2100	3650	800	950	1150	1700

5.4.3 Vacuum balance line

	<b>NOTE</b>
	Where fluid has to be pumped out of a vessel under vacuum, installing a vacuum balance line is recommended.

The following rules apply to vacuum balance lines:

- Minimum nominal line diameter 25 mm.
- The line extends above the highest permissible fluid level in the vessel.

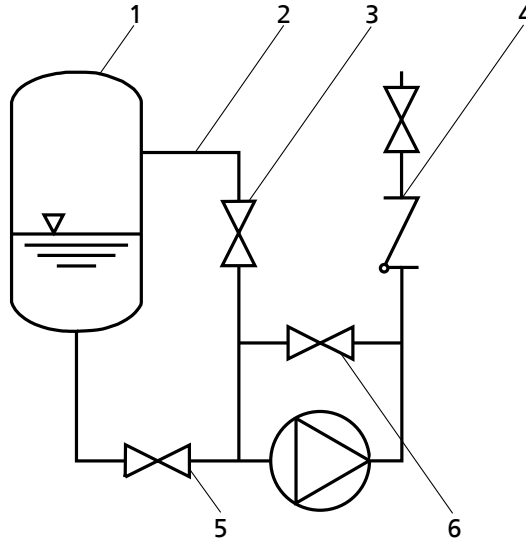




Fig. 8: Vacuum balance system

1	Vessel under vacuum	2	Vacuum balance line
3	Shut-off element	4	Swing check valve
5	Main shut-off element	6	Vacuum-tight shut-off element

	<b>NOTE</b>
	An additional line fitted with a shut-off valve (from the pump discharge nozzle to the balance line) facilitates venting of the pump before start-up.

5.5 Auxiliary connections

	<b>WARNING</b>
	<p><b>Screw plugs subjected to pressure</b> Risk of injuries by parts flying off and escaping fluid!</p> <ul style="list-style-type: none"> <li>▷ Never use screw plugs for releasing pressure from the pump casing.</li> <li>▷ Always use suitable venting devices (e.g. vent valve).</li> </ul>

The following auxiliary connections are available:

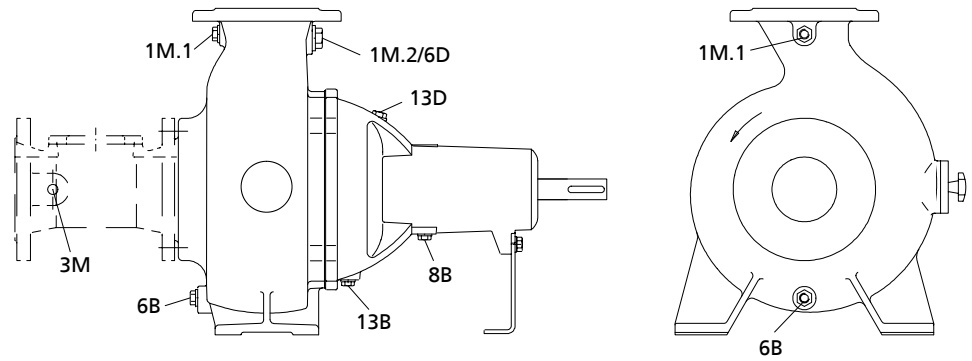





Fig. 9: Auxiliary connections

Table 12: Sizes of auxiliary connections


Connection	Description	Size						
		050-215 050-216 050-250 050-251	065-215 065-216 065-217 065-250 065-252 065-253	080-215 080-216 080-217 080-250 080-252 080-253 080-315 080-316 080-317	150-315 150-317 200-315 200-316 200-317 200-318	100-401 K 100-400 D 100-403	150-400 150-403 200-402 200-403 200-405	250-401 250-403 300-400 300-401 250-402 300-402
1M.1	Pressure gauge	G 1/2						
1M.2 <sup>6)</sup>	Pressure gauge	-			G 1/2			
6D	Vent	G 1/2	G 3/4	G 1		G 1 1/4		
3M	Pressure/vacuum gauge	G 1/2						
6B	Casing drain	G 1/2			G 1			
8B	Leakage monitoring	G 3/8						
13D	Lubricant filler opening	G 1/2						
13B	Lubricant drain	G 3/8						

### 5.6 Checking the coupling alignment

 	 <b>DANGER</b>
	<p>Inadmissible temperatures at the coupling or bearings due to misalignment of the coupling  Explosion hazard!  Risk of burns!</p> <p>► Make sure that the coupling is correctly aligned at all times.</p>

2580.815/14-EN

<sup>6</sup> For vertical installation only

	<b>CAUTION</b>
	<p><b>Misalignment of pump and motor shafts</b>                  Damage to pump, motor and coupling!</p> <ul style="list-style-type: none"> <li>▷ Always check the coupling after the pump has been installed and connected to the piping.</li> <li>▷ Also check the coupling of pump sets supplied with pump and motor mounted on the same baseplate.</li> </ul>

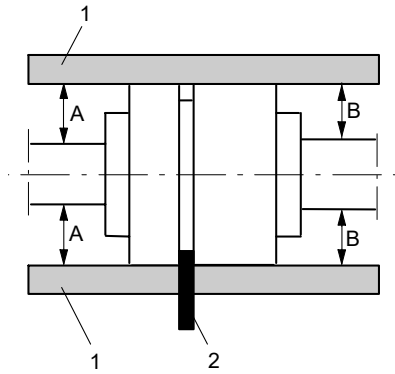


Fig. 10: Non-spacer-type coupling, checking the coupling alignment

1	Straight edge	2	Gauge
---	---------------	---	-------

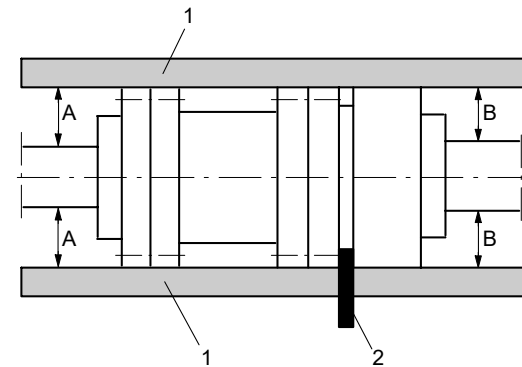


Fig. 11: Spacer-type coupling, checking the coupling alignment

1	Straight edge	2	Gauge
---	---------------	---	-------

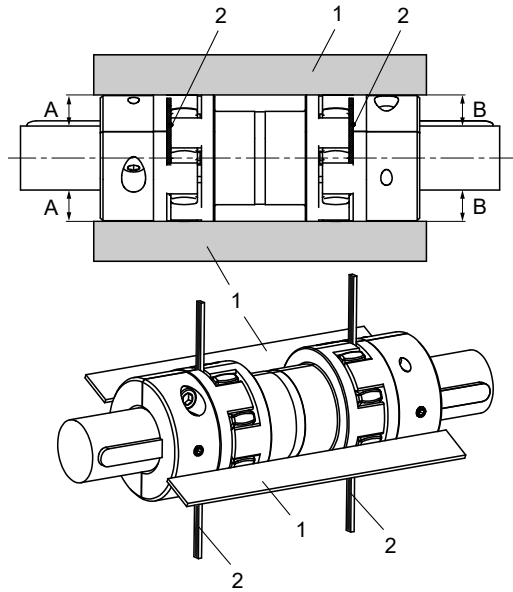


Fig. 12: Double Cardan spacer-type coupling, checking the coupling alignment

1	Straight edge	2	Gauge
---	---------------	---	-------

Table 13: Permissible alignment offset of coupling halves

Coupling type	Radial offset	Axial offset
	[mm]	[mm]
Non-spacer-type coupling (⇒ Fig. 10)	≤ 0,1	≤ 0,1
Spacer-type coupling (⇒ Fig. 11)	≤ 0,1	≤ 0,1
Double Cardan coupling (⇒ Fig. 12)	≤ 0,5	≤ 0,5

- ✓ The coupling guard and its footboard, if any, have been removed.
  1. Loosen the support foot and re-tighten it without transmitting any stresses and strains.
  2. Place the straight edge axially on both coupling halves.
  3. Leave the straight edge in this position and turn the coupling by hand.  
The coupling is aligned correctly if the distances A and B to the respective shafts are the same at all points around the circumference.  
Observe the permissible radial offset in coupling half alignment (⇒ Table 13) both during standstill and at operating temperature as well as under inlet pressure.
  4. Check the distance (dimension see general arrangement drawing) between the two coupling halves around the circumference.  
The coupling is correctly aligned if the distance between the two coupling halves is the same at all points around the circumference.  
Observe the permissible axial offset in coupling half alignment (⇒ Table 13) both during standstill and at operating temperature as well as under inlet pressure.
  5. If alignment is correct, re-install the coupling guard and its footboard, if any.

**Checking the coupling alignment with a laser tool**

Coupling alignment may also be checked with a laser tool. Observe the documentation provided by the manufacturer of the measuring instrument.

### 5.7 Checking the belt drive

#### 5.7.1 Checking the pulley alignment

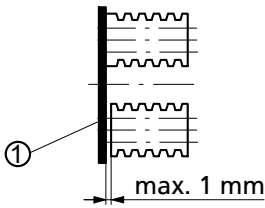


Fig. 13: Checking the pulley alignment

- ✓ The belt guard has been removed.
- ✓ Required tools: wedge gauge, straight-edge

  1. Place the straight-edge (1) vertically on both pulleys.
  2. Leave the straight-edge (1) in this position and turn the measuring point by hand.
  3. Adjust the alignment, if required. (⇒ Section 7.5.8, Page 73)
  4. Re-fit the belt guard.

#### 5.7.2 Tensioning the belts

	<b>CAUTION</b>
	<p><b>Lack of tension</b> Insufficient power transmission! Wear resulting from excessive slip!</p> <p>▷ Check the tension forces.</p>
	<b>CAUTION</b>
	<p><b>Excessive tension</b> Service life reduced by excessive stretching, unnecessary flexing work or excessive temperatures!</p> <p>▷ Check the tension forces.</p>

901.59

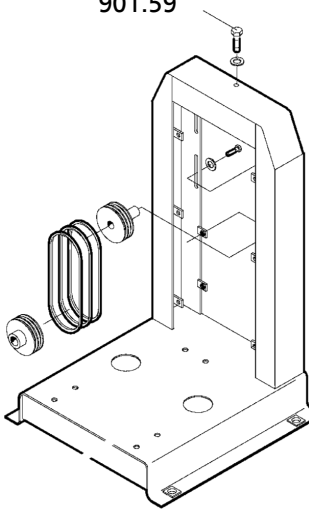


Fig. 14: Tensioning the belts

1. Adjust the tension by tightening and loosening bolt 901.59.
2. Check the tension again between ½ hour and 1 hour after initial tensioning.
3. Observe the V-belt tension and deflection described in the following table.

Check the belt tension with a suitable measuring device (not included in the scope of supply).

Table 14: V-belt tension and deflection

Surface type	Test force per V-belt	Diameter of smallest pulley	Static belt tension				Deflection per 100 mm centre distance	
			Standard		Raw edge		Standard	Raw edge
			Initial installation	After running in	Initial installation	After running in		
			[N]	[N]	[N]	[N]	[mm]	[mm]
SPA XPA	50	71 < 100	350	250	400	300	3,2	2,9
		> 100 < 140	400	300	500	400	2,75	2,55
		> 140 < 200	500	400	600	450	2,55	2,4
		> 200					2,45	2,3
SPB XPB	75	< 160	650	500	700	550	3,0	2,55
		> 160 < 224	700	550	850	650	2,55	2,2
		> 224 < 355	900	700	1000	800	2,25	1,85
		> 355					2,1	1,75
SPC XPC	125	180 < 250	350	250	400	300	2,55	2,2
		> 250 < 355	400	300	500	400	2,2	2,05
		> 355 < 560	500	400	600	450	2,0	1,9
		> 560					1,9	1,7

2580.815/14-EN



	<b>⚠ WARNING</b>
	<p><b>Failure to re-install or re-activate protective devices</b>          Risk of injury from moving parts or escaping fluid!</p> <ul style="list-style-type: none"> <li>▸ As soon as the work is completed, properly re-install and re-activate any safety-relevant devices and protective devices.</li> </ul>

### 5.8 Aligning the pump and motor

After having installed the pump set and connected the piping, check the coupling alignment and, if required, re-align the pump set (at the motor).

#### 5.8.1 Motors with adjusting screw

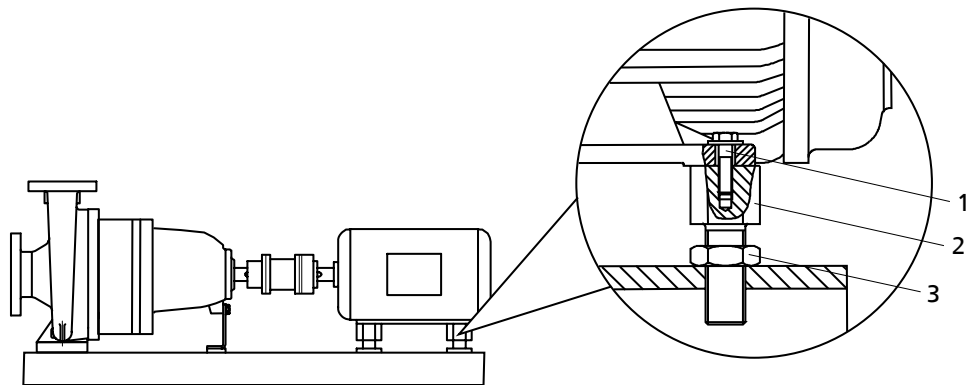


Fig. 15: Motor with adjusting screw

1	Hexagon head bolt	2	Adjusting screw
3	Locknut		

- ✓ The coupling guard and its footboard, if any, have been removed.
- 1. Check the coupling alignment.
- 2. Unscrew the hexagon head bolts (1) at the motor and the locknuts (3) at the baseplate.
- 3. Turn the adjusting screws (2) by hand or by means of an open-end wrench until the coupling alignment is correct and all motor feet rest squarely on the baseplate.
- 4. Re-tighten the hexagon head bolts (1) at the motor and the locknuts (3) at the baseplate.
- 5. Check proper functioning of coupling/shaft.  
 Check that coupling/shaft can easily be rotated by hand.

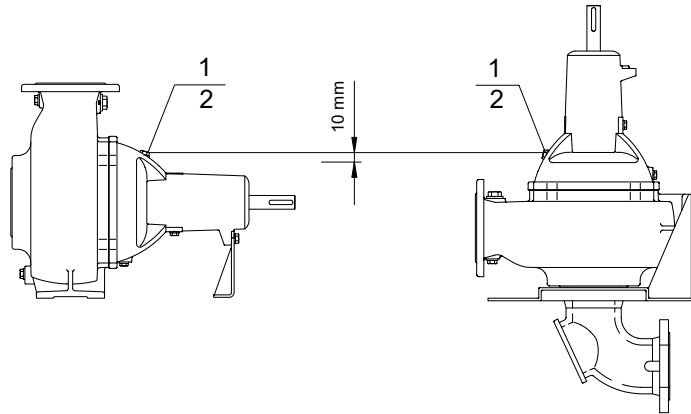
	<b>⚠ WARNING</b>
	<p><b>Unprotected rotating coupling</b>          Risk of injury by rotating shafts!</p> <ul style="list-style-type: none"> <li>▸ Always operate the pump set with a coupling guard.              If the customer specifically requests not to include a coupling guard in KSB's delivery, then the operator must supply one!</li> <li>▸ Observe all relevant regulations for selecting a coupling guard.</li> </ul>

	<b>⚠ DANGER</b>
	<p><b>Risk of ignition by frictional sparks</b>          Explosion hazard!!</p> <ul style="list-style-type: none"> <li>▸ Choose a coupling guard material that is non-sparking in the event of mechanical contact.</li> </ul>

6. Fit the coupling guard and its footboard, if any.
7. Check the distance between coupling and coupling guard.  
The coupling guard must not touch the coupling.

**5.9 Checking the lubricants**

- Grease-lubricated bearings
    - Grease-lubricated bearings have been packed with grease at the factory.
  - Lubricant reservoir for the mechanical seal
    - The lubricant reservoirs have been filled at the factory.
1. Before commissioning the pump set, check the lubricant level.



**Fig. 16:** Checking the lubricants

- ✓ The pump set has been installed as described in this manual.
1. Unscrew and remove screw plug (1) with joint ring (2).
  2. If the lubricant level is within the 10 mm tolerance range below the opening, re-insert and fasten screw plug (1) with joint ring (2).
  3. If the lubricant level is below the tolerance range, fill in more lubricant.  
(⇒ Section 7.2.3.2, Page 47)

**5.10 Electrical connection**

	<p><b>⚠ DANGER</b></p>
	<p><b>Electrical connection work by unqualified personnel</b>                  Danger of death from electric shock and explosion!</p> <ul style="list-style-type: none"> <li>▷ Always have the electrical connections installed by an electrically qualified person.</li> <li>▷ Observe regulations IEC 60364 and, for explosion-proof versions, EN 60079 .</li> </ul>
	<p><b>⚠ DANGER</b></p>
	<p><b>Incorrect electrical installation</b>                  Danger of death from electric shock!</p> <ul style="list-style-type: none"> <li>▷ For electrical installation, also observe the requirements of IEC 60079-14.</li> <li>▷ Always connect explosion-proof motors via a motor protection switch.</li> </ul>

2580.815/14-EN

	<b>⚠ WARNING</b>
	<p><b>Incorrect connection to the mains</b>          Damage to the power supply network, short circuit!</p> <ul style="list-style-type: none"> <li>▷ Observe the technical specifications of the local energy supply companies.</li> </ul>

1. Check the available mains voltage against the data on the motor name plate.
2. Select an appropriate starting method.

	<b>NOTE</b>
	<p>Installing a motor protection device is recommended.</p>

### 5.11 Checking the direction of rotation

	<b>⚠ DANGER</b>
	<p><b>Temperature increase resulting from contact between rotating and stationary components</b>          Explosion hazard!          Damage to the pump set!</p> <ul style="list-style-type: none"> <li>▷ Never check the direction of rotation by starting up the unfilled pump set.</li> <li>▷ Separate the pump from the motor to check the direction of rotation.</li> </ul>

	<b>⚠ WARNING</b>
	<p><b>Hands inside the pump casing</b>          Risk of injuries, damage to the pump!</p> <ul style="list-style-type: none"> <li>▷ Always disconnect the pump set from the power supply and secure it against unintentional start-up before inserting your hands or other objects into the pump.</li> </ul>

	<b>CAUTION</b>
	<p><b>Incorrect direction of rotation with non-reversible mechanical seal</b>          Damage to the mechanical seal and leakage!</p> <ul style="list-style-type: none"> <li>▷ Separate the pump from the motor to check the direction of rotation.</li> </ul>

	<b>CAUTION</b>
	<p><b>Drive and pump running in the wrong direction of rotation</b>          Damage to the pump!</p> <ul style="list-style-type: none"> <li>▷ Refer to the arrow indicating the direction of rotation on the pump.</li> <li>▷ Check the direction of rotation. If required, check the electrical connection and correct the direction of rotation.</li> </ul>

The correct direction of rotation of the motor and pump is clockwise (seen from the drive end).

1. Start the motor and stop it again immediately to determine the motor's direction of rotation.
2. Check the direction of rotation.  
 The motor's direction of rotation must match the arrow indicating the direction of rotation on the pump.
3. If the motor is running in the wrong direction of rotation, check the electrical connection of the motor and switchgear, if any.

### 5.12 Priming and venting the pump

	<b>DANGER</b>
	<p><b>Shaft seal failure caused by insufficient lubrication</b>          Hot or toxic fluid could escape!          Damage to the pump!</p> <ul style="list-style-type: none"> <li>▷ Before starting up the pump set, vent the pump and suction line and prime both with the fluid to be handled.</li> </ul>

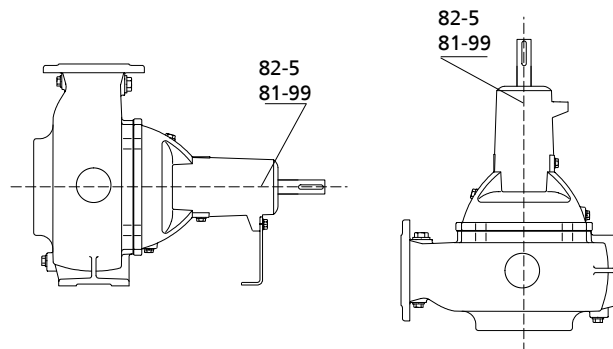
1. Vent the pump and suction line and prime both with the fluid to be handled.
2. Fully open the shut-off valve in the suction line.
3. Fully open all auxiliary connections (barrier fluid, flushing liquid, etc).

### 5.13 Protective devices

	<b>WARNING</b>
	<p><b>Failure to re-install or re-activate protective devices</b>          Risk of injury from moving parts or escaping fluid!</p> <ul style="list-style-type: none"> <li>▷ As soon as the work is completed, properly re-install and re-activate any safety-relevant devices and protective devices.</li> </ul>

### 5.14 Connecting the vibration sensor

The pump is supplied prepared for the connection of a vibration sensor as an option. Fasten the vibration sensor at the point indicated at the bearing bracket. Observe the technical literature of the sensor for fastening and electrical wiring.

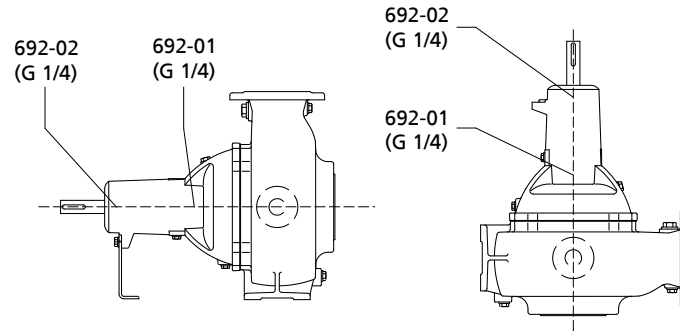


**Fig. 17:** Position of vibration sensor

82-5	Adapter	81-99	Electric part
------	---------	-------	---------------

### 5.15 Connecting temperature measuring devices

The pump is supplied prepared for the connection of resistance thermometers as an option. Fasten the resistance thermometers at the points indicated at the bearing bracket. Observe the technical literature of the sensor for fastening and electrical wiring.



**Fig. 18:** Positions of resistance thermometers

692-01	Temperature measuring device No. 1	692-02	Temperature measuring device No. 2
--------	------------------------------------	--------	------------------------------------

### 5.16 Warning and trip values

As an option, the pump can be fitted with various sensors. If such sensors are fitted, observe the following warning values and trip values:

**Table 15:** Warning values and trip values

Sensors		Warning value	Trip value
Vibrations <sup>7)</sup> of pumps with a drive rating < 200 kW	[mm/s - rms]	6,3 <sup>8)</sup>	9,5
Vibrations of pumps with a drive rating > 200 kW	[mm/s - rms]	7,6	11,9
Bearing temperature at the outer bearing ring	[°C]	85	90

<sup>7)</sup> To DIN ISO 10816-7, category II, zone A

<sup>8)</sup> Within the preferred operating range of  $0.7 \leq Q/Q_{BEP} \leq 1.2$  the vibration values of newly commissioned pumps with good system conditions (piping layout, approach flow at the pump, etc.) are below the limits of zone A to DIN ISO 10816-7, i.e. below 3.5 mm/s rms.

## 6 Commissioning/Start-up/Shutdown









### 6.1 Commissioning/Start-up



#### 6.1.1 Prerequisites for commissioning/start-up

Before commissioning/starting up the pump set, make sure that the following conditions are met:

- The pump set has been properly connected to the power supply and is equipped with all protection devices.
- The pump has been filled with the fluid to be handled. The pump has been vented.
- The direction of rotation has been checked. (⇒ Section 5.11, Page 35)
- All auxiliary connections required are connected and operational.
- The lubricant has been checked.
- After prolonged shutdown of the pump (set), the activities required for returning the equipment to service have been carried out.


#### 6.1.2 Start-up

 	 <b>DANGER</b>
	<p><b>Non-compliance with the permissible pressure and temperature limits if the pump is operated with the suction and/or discharge line closed.</b>  Explosion hazard!  Hot or toxic fluids escaping!</p> <ul style="list-style-type: none"> <li>▷ Never operate the pump with the shut-off elements in the suction line and/or discharge line closed.</li> <li>▷ Only start up the pump set with the discharge-side shut-off element slightly or fully open.</li> </ul>
 	 <b>DANGER</b>
	<p><b>Excessive temperatures due to dry running or excessive gas content in the fluid handled</b>  Explosion hazard!  Damage to the pump set!</p> <ul style="list-style-type: none"> <li>▷ Never operate the pump set without liquid fill.</li> <li>▷ Prime the pump as per operating instructions.</li> <li>▷ Always operate the pump within the permissible operating range.</li> <li>▷ If the pump is in slurp mode, stop the pump immediately.</li> </ul>
	 <b>WARNING</b>
	<p><b>Pump sets with high noise levels</b>  Damage to hearing!</p> <ul style="list-style-type: none"> <li>▷ Persons must only enter the vicinity of the running pump set if they are wearing protective clothing/ear protection.</li> <li>▷ See noise characteristics. (⇒ Section 4.7, Page 19)</li> </ul>

	 <b>WARNING</b>
	<p><b>Abnormal noises, vibrations, temperatures or leakage</b>            Damage to the pump!            Risk of personal injury!</p> <ul style="list-style-type: none"> <li>▷ Switch off the pump (set) immediately.</li> <li>▷ Eliminate the causes before returning the pump set to service.</li> </ul>

- ✓ The pump, suction line and discharge line have been vented and primed with the fluid to be handled.
- 1. Fully open the shut-off element in the suction head/suction lift line.
- 2. Close/slightly open the shut-off element in the discharge line; fully open the shut-off element if a check valve is installed.
- 3. Start up the motor.
- 4. Immediately after the pump has reached full rotational speed, swiftly open the shut-off element in the discharge line and adjust it to comply with the duty point.

**Frequency inverter** When the pump is started up via frequency inverter, ensure short start ramps (approximately 3 - 5 seconds).

	<b>NOTE</b>
	<p>Speed-controlled operation shall only start after approximately 3 to 5 minutes.            Pump start-up with long start ramps and low frequency may cause clogging.</p>




**6.1.3 Shutdown**

1. Close the shut-off element in the discharge line.  
 If the discharge line is equipped with a check valve, the shut-off element may remain open as long as there is back pressure.
2. Switch off the motor, making sure that the unit runs down smoothly to a standstill.

**Prolonged shutdown periods** For prolonged shutdown, close the shut-off element in the suction line.

**Danger of frost/freezing** If there is any danger of frost/freezing, drain the pump and protect it against freezing.

**6.2 Operating limits**

 	 <b>DANGER</b>
	<p><b>Non-compliance with operating limits for pressure, temperature, fluid handled and speed</b>            Explosion hazard!            Hot or toxic fluid could escape!</p> <ul style="list-style-type: none"> <li>▷ Comply with the operating data specified in the data sheet.</li> <li>▷ Never use the pump for handling fluids it is not designed for.</li> <li>▷ Avoid prolonged operation against a closed shut-off element.</li> <li>▷ Never operate the pump at temperatures, pressures or rotational speeds exceeding those specified in the data sheet or on the name plate unless the written consent of the manufacturer has been obtained.</li> </ul>

2580.815/14-EN

	<b>DANGER</b>
	<p><b>Formation of a potentially explosive atmosphere inside the pump</b> Explosion hazard!</p> <p>▷ When draining tanks take suitable measures to prevent dry running of the pump (e.g. fill level monitoring).</p>

### 6.2.1 Maximum operating pressure, maximum test pressure

	<b>CAUTION</b>
	<p><b>Permissible operating pressure exceeded</b> Damage to connections and seals!</p> <p>▷ Never exceed the operating pressure specified in the data sheet.</p>

**Table 16:** Maximum operating pressure, maximum test pressure

Size	Maximum operating pressure	Maximum test pressure
	[bar]	
050 - 215	10	15
050 - 216	10	15
050 - 250	10	15
050 - 251	10	15
065 - 215	6	9
065 - 216	6	9
065 - 217	7	10,5
065 - 250	6	9
065 - 252	6	9
065 - 253	6	9
080 - 215	6	8,5
080 - 216	7	10,5
080 - 217	6	9
080 - 250	6	9
080 - 252	6	9
080 - 253	6	9
080 - 315	10	15
080 - 316	10	15
080 - 317	10	15
100 - 215	6	9
100 - 250	6	9
100 - 251	6	9
D 100 - 251	6	9
100 - 252	6	9
100 - 253	6	9
D 100 - 253	6	9
100 - 254	6	9
100 - 315	10	15
100 - 316	6	9
D 100 - 316	10	15
100 - 317	7	10,5
K 100 - 400	10	15
100 - 401	10	15



Size	Maximum operating pressure	Maximum test pressure
	[bar]	
100 - 403	10	15
150 - 251	6	9
150 - 253	6	9
150 - 315	6	9
150 - 317	6	9
150 - 400	10	15
150 - 401	10	15
150 - 403	10	15
151 - 403	10	15
200 - 315	6	9
200 - 316	6	9
200 - 317	4	6
200 - 318	4	6
K 200 - 402	10	15
200 - 403	10	15
200 - 405	10	15
250 - 401	10	15
250 - 402	10	15
250 - 403	10	15
300 - 400	10	15
300 - 401	10	15
300 - 402	10	15

**6.2.2 Frequency of starts**

To prevent high temperature increases in the motor and excessive loads on the pump, coupling, V-belts, motor, seals and bearings, the frequency of starts shall not exceed the following number of start-ups per hour.

**Table 17:** Frequency of starts

Rated motor power [kW]	Maximum frequency of starts [Starts/hour]
≤ 11	25
12 - 37	20


**6.2.3 Fluid handled**

**6.2.3.1 Temperature of the fluid handled**

	<b>CAUTION</b>
	<p><b>Impermissibly high temperature of fluid handled</b> Damage to the pump!</p> <ul style="list-style-type: none"> <li>▷ Prolonged operation against a closed shut-off element is not permitted (heating up of the fluid).</li> <li>▷ Observe the temperature limits in the data sheet and in the section on operating limits. (⇒ Section 6.2, Page 39)</li> </ul>

**6.2.3.2 Density of the fluid handled**

The power input of the pump set will change in proportion to the density of the fluid handled.

	<b>CAUTION</b>
	<p><b>Impermissibly high density of the fluid handled</b> Motor overload!</p> <ul style="list-style-type: none"> <li>▷ Observe the information about fluid density in the data sheet.</li> <li>▷ Make sure the motor has sufficient power reserves.</li> </ul>

### 6.2.3.3 Abrasive fluids

Do not exceed the maximum permissible solids content specified in the data sheet. When the pump handles fluids containing abrasive substances, increased wear of the hydraulic system and the shaft seal are to be expected. In this case, halve the intervals commonly recommended for servicing and maintenance.

## 6.3 Shutdown/storage/preservation

### Storing a new pump set

If commissioning is to take place some time after delivery, we recommend that the following measures be taken for pump (set) storage:

- Store the pump (set) in a dry and protected location.
- If properly stored indoors, the pump set is protected for a maximum of 12 months.  
New pumps are supplied by our factory duly prepared for storage.
- Rotate the shaft of the pump by hand once a month.

### The pump (set) remains installed

- ✓ Sufficient fluid is supplied for the functional check run of the pump.
  1. For prolonged shutdown periods, start up the pump (set) regularly between once a month and once every three months for approximately five minutes.
    - ⇒ This will prevent the formation of deposits within the pump and the pump intake area.



### The pump (set) is removed from the pipe and stored

- ✓ The pump has been properly drained. (⇒ Section 7.3, Page 50)
- ✓ The safety instructions for dismantling the pump have been observed. (⇒ Section 7.4.1, Page 50)
- ✓ The permissible ambient temperature for storing the pump is observed.
  1. Spray-coat the inside wall of the pump casing and, in particular, the impeller clearance areas with a preservative.
  2. Spray the preservative through the suction nozzle and discharge nozzle. It is advisable to then close the pump nozzles (e.g. with plastic caps)
  3. Oil or grease all exposed machined parts and surfaces of the pump (with silicone-free oil or grease, food-approved, if required) to protect them against corrosion.  
Observe the additional instructions on preservation.

## 6.4 Returning to service












For returning the equipment to service, observe the sections on commissioning/start-up (⇒ Section 6.1, Page 38) and the operating limits (⇒ Section 6.2, Page 39) .

In addition, carry out all servicing/maintenance operations before returning the pump (set) to service. (⇒ Section 7, Page 44)

	<p style="background-color: #f4a460; padding: 2px;"><b>⚠ WARNING</b></p> <p><b>Failure to re-install or re-activate protective devices</b>          Risk of injury from moving parts or escaping fluid!</p> <ul style="list-style-type: none"> <li>▷ As soon as the work is completed, properly re-install and re-activate any safety-relevant devices and protective devices.</li> </ul>
	<p style="background-color: #0070c0; color: white; padding: 2px;"><b>NOTE</b></p> <p>On pumps/pump sets older than 5 years we recommend replacing all elastomer seals.</p>

## 7 Servicing/Maintenance

### 7.1 Safety regulations

	<p style="background-color: #e67e22; color: white; padding: 5px;"> <b>DANGER</b></p> <p><b>Improper cleaning of coated pump surfaces</b> Explosion hazard by electrostatic discharge!</p> <ul style="list-style-type: none"> <li>▷ When cleaning coated pump surfaces in atmospheres of Explosion group IIC, use suitable anti-static equipment.</li> </ul>
	<p style="background-color: #e67e22; color: white; padding: 5px;"> <b>DANGER</b></p> <p><b>Sparks produced during servicing work</b> Explosion hazard!</p> <ul style="list-style-type: none"> <li>▷ Observe the safety regulations in force at the place of installation!</li> <li>▷ Always perform maintenance work at an explosion-proof pump (set) outside of potentially explosive atmospheres.</li> </ul>
 	<p style="background-color: #e67e22; color: white; padding: 5px;"> <b>DANGER</b></p> <p><b>Improperly serviced pump set</b> Explosion hazard! Damage to the pump set!</p> <ul style="list-style-type: none"> <li>▷ Service the pump set regularly.</li> <li>▷ Prepare a maintenance schedule with special emphasis on lubricants, shaft seal and coupling.</li> </ul>
<p>The operator ensures that maintenance, inspection and installation are performed by authorised, qualified specialist personnel who are thoroughly familiar with the manual.</p>	
	<p style="background-color: #f1c40f; padding: 5px;"> <b>WARNING</b></p> <p><b>Unintentional starting of the pump set</b> Risk of injury by moving components and shock currents!</p> <ul style="list-style-type: none"> <li>▷ Ensure that the pump set cannot be started unintentionally.</li> <li>▷ Always make sure the electrical connections are disconnected before carrying out work on the pump set.</li> </ul>
	<p style="background-color: #f1c40f; padding: 5px;"> <b>WARNING</b></p> <p><b>Fluids handled, consumables and supplies which are hot and/or pose a health hazard</b> Risk of injury!</p> <ul style="list-style-type: none"> <li>▷ Observe all relevant laws.</li> <li>▷ When draining the fluid take appropriate measures to protect persons and the environment.</li> <li>▷ Decontaminate pumps which handle fluids posing a health hazard.</li> </ul>

	<b>⚠ WARNING</b>
	<p><b>Insufficient stability</b> Risk of crushing hands and feet!</p> <ul style="list-style-type: none"> <li>▷ During assembly/dismantling, secure the pump (set)/pump parts to prevent tilting or tipping over.</li> </ul>

A regular maintenance schedule will help avoid expensive repairs and contribute to trouble-free, reliable operation of the pump, pump set and pump parts with a minimum of servicing/maintenance expenditure and work.

	<b>NOTE</b>
	<p>All maintenance work, service work and installation work can be carried out by KSB Service or authorised workshops. For contact details refer to the enclosed "Addresses" booklet or visit "<a href="https://www.ksb.com/en-global/contact">https://www.ksb.com/en-global/contact</a>" on the Internet.</p>

Never use force when dismantling and reassembling the pump set.

## 7.2 Servicing/inspection

### 7.2.1 Supervision of operation

	<b>⚠ DANGER</b>
	<p><b>Formation of a potentially explosive atmosphere inside the pump</b> Explosion hazard!</p> <ul style="list-style-type: none"> <li>▷ The pump internals in contact with the fluid to be handled, including the seal chamber and auxiliary systems must be filled with the fluid to be handled at all times.</li> <li>▷ Provide sufficient inlet pressure.</li> <li>▷ Provide an appropriate monitoring system.</li> <li>▷ If the pump is in slurp mode, stop the pump immediately.</li> </ul>

	<b>CAUTION</b>
	<p><b>Increased wear due to dry running</b> Damage to the pump set!</p> <ul style="list-style-type: none"> <li>▷ Never operate the pump set without liquid fill.</li> <li>▷ Never close the shut-off element in the suction line and/or supply line during pump operation.</li> </ul>

 	<b>⚠ DANGER</b>
	<p><b>Non-compliance with operating limits for pressure, temperature, fluid handled and speed</b> Explosion hazard! Hot or toxic fluid could escape!</p> <ul style="list-style-type: none"> <li>▷ Comply with the operating data specified in the data sheet.</li> <li>▷ Never use the pump for handling fluids it is not designed for.</li> <li>▷ Avoid prolonged operation against a closed shut-off element.</li> <li>▷ Never operate the pump at temperatures, pressures or rotational speeds exceeding those specified in the data sheet or on the name plate unless the written consent of the manufacturer has been obtained.</li> </ul>

While the system is in operation, observe and check the following:

- The pump must run quietly and free from vibrations at all times.
- Monitor the correct functioning of any auxiliary connections.
- Monitor the stand-by pump.  
To make sure that stand-by pumps are ready for operation, start them up once a week.
- Check the flexible elements of the coupling or belts and replace them if required.
- For bearing temperature monitoring, set the temperatures as follows: alert at 85 °C, pump cut-out at 90 °C.
- For vibration monitoring, set the values as follows: alert at 6.3 mm/s, pump cut-out at 9.5 mm/s.

**7.2.2 Inspection work**

	<b>DANGER</b>
	<p><b>Electrostatic charging</b> Explosion hazard! Damage to the pump set!</p> <ul style="list-style-type: none"> <li>▷ Connect the potential equalisation conductor to the earthing terminal provided.</li> <li>▷ Make sure that the connection between pump and baseplate is electrically conductive.</li> <li>▷ Screws, bolts, nuts and shims must not be coated or the coating must be removed.</li> <li>▷ Provide potential equalisation between the pump set and the foundation.</li> </ul>

**7.2.2.1 Visual inspection through the inspection hole**

If there are problems with clogging, the inside of the casing and the impeller can be checked via the inspection hole.

	<b>WARNING</b>
	<p><b>Fluids handled, consumables and supplies which are hot and/or pose a health hazard</b> Hazard to persons and the environment!</p> <ul style="list-style-type: none"> <li>▷ Collect and properly dispose of flushing fluid and any fluid residues.</li> <li>▷ Wear safety clothing and a protective mask if required.</li> <li>▷ Observe all legal regulations on the disposal of fluids posing a health hazard.</li> </ul>

	<b>WARNING</b>
	<p><b>Hands or foreign objects in the pump casing</b> Risk of injuries, damage to the pump!</p> <ul style="list-style-type: none"> <li>▷ Check that the inside of the pump is free from any foreign objects. Remove any foreign objects.</li> <li>▷ Never insert your hands or any other objects into the pump, if the pump set has not been disconnected from the power supply and secured against unintentional start-up.</li> </ul>

If a problem has occurred which requires visual inspection, observe the following instructions:

2580.815/14-EN

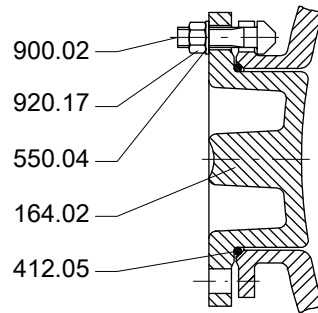


Fig. 19: Inspection hole in the casing

**Opening the inspection hole**

- Close the shut-off element on the suction side.
- Switch off the drive and make sure it cannot be re-started unintentionally.
- Close the shut-off element on the discharge side.
- Open the drain plug (auxiliary connection 6B). (⇒ Section 5.5, Page 28)
- Collect and dispose of any liquid residues.
- Loosen nuts 920.17 at the inspection hole. Remove inspection cover 164.02.
- Perform a visual inspection with a lamp or similar.

**Closing the inspection hole**

- Fit new O-ring 412.05.
- Fit inspection cover 164.02.
- Fit discs 550.04 and nuts 920.17 on screws 900.02. Tighten the nuts.
- Observe the instructions on commissioning/start-up. (⇒ Section 6.1.1, Page 38)

**7.2.3 Lubrication and lubricant change**

	<p><b>⚠ DANGER</b></p>
	<p><b>Excessive temperatures as a result of bearings running hot or defective bearing seals</b></p> <p>Explosion hazard! Fire hazard! Damage to the pump set!</p> <p>▷ Regularly check the condition of the lubricant.</p>

**7.2.3.1 Lubricating the rolling element bearings**

The rolling element bearings of the pump sets are grease-packed and maintenance-free.

**7.2.3.2 Changing the lubricant of the mechanical seal**

	<p><b>⚠ DANGER</b></p>
	<p><b>Excessive temperatures in the shaft seal area</b></p> <p>Explosion hazard! Damage to the pump set!</p> <p>▷ Regularly check the lubricant level.</p>

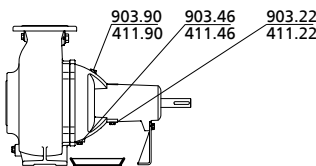
2580.815/14-EN

	<b>! WARNING</b>
	<p><b>Lubricants posing a health hazard and/or hot lubricants</b>            Hazard to persons and the environment!</p> <ul style="list-style-type: none"> <li>▷ When draining the lubricant take appropriate measures to protect persons and the environment.</li> <li>▷ Wear safety clothing and a protective mask if required.</li> <li>▷ Collect and dispose of any lubricants.</li> <li>▷ Observe all legal regulations on the disposal of fluids posing a health hazard.</li> </ul>

	<b>! WARNING</b>
	<p><b>Screw plugs subjected to pressure</b>            When opening screw plugs, liquid might spurt out!</p> <ul style="list-style-type: none"> <li>▷ Wear safety goggles and protective clothing, if required.</li> <li>▷ Open the screw plug slowly.</li> </ul>

The lubricant reservoir of the pump set is filled at the factory with environmentally-friendly, non-toxic lubricant of medical quality.

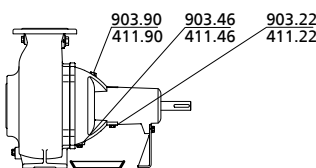
**Draining the lubricant**



**Fig. 20:** Draining the lubricant

- ✓ Have a suitable container on hand for the used lubricant.
- 1. Place the container underneath screw plug 903.46.
- 2. Remove screw plug 903.46 and joint ring 411.46 at the bottom side of the bearing bracket and drain off the lubricant.
- 3. Fit screw plug 903.46 with joint ring 411.46.

	<b>NOTE</b>
	<p>Paraffin oil is bright and transparent in appearance.            If the oil fill is severely contaminated, this will suggest a defective mechanical seal.            The mechanical seal should be replaced.</p>



**Fig. 21:** Filling in the lubricant

**Filling in the lubricant**

1. Unscrew and remove screw plug 903.90 with joint ring 411.90.
2. Fill the lubricant reservoir up to the filler opening.
3. Fit screw plug 903.90 with joint ring 411.90.

**Intervals** Change the lubricant every 10,000 operating hours, but at least every three years.



7.2.3.3 Lubricant quantity

Table 18: Lubricant quantity [l]

Size	Bearing bracket	Lubricant quantity
050 - 215	S01	2,5
050 - 216	S01	2,5
050 - 250	S01	3,2
050 - 251	S02	4,0
065 - 215	S01	2,5
065 - 216	S01	2,5
065 - 217	S01	2,5
065 - 250	S01	3,2
065 - 252	S01	3,2
065 - 252	S02	4,0
065 - 253	S01	3,2
065 - 253	S02	4,0
080 - 215	S01	2,5
080 - 216	S01	2,5
080 - 217	S01	2,5
080 - 250	S01	3,2
080 - 252	S01	3,2
080 - 253	S02	4,0
080 - 315	S03	6,0
080 - 316	S03	6,0
080 - 317	S03	6,0
100 - 215	S01	2,5
100 - 250	S01	3,2
100 - 251	S02	4,0
100 - 252	S01	3,2
100 - 253	S02	4,0
100 - 254	S01	3,2
100 - 315	S03	6,0
100 - 316	S03	6,0
100 - 317	S03	6,0
100 - 400	S04	8,0
100 - 401	S04	8,0
150 - 251	S02	4,0
150 - 253	S02	4,0
150 - 315	S03	6,0
150 - 317	S03	6,0
150 - 400	S04	8,0
150 - 401	S04	8,0
150 - 403	S04	8,0
200 - 315	S03	6,0
200 - 316	S03	6,0
200 - 317	S03	6,0
200 - 318	S03	6,0
200 - 402	S04	8,0
200 - 403	S04	8,0
250 - 401	S04	8,0
250 - 403	S04	8,0

Size	Bearing bracket	Lubricant quantity
300 - 400	S04	8,0
300 - 401	S04	8,0

**7.2.3.4 Lubricant quality**

**Recommended lubricant quality**

**Alternative**

- Environmentally friendly, non-toxic white oil of medical quality
- Thin-bodied paraffin oil, non-toxic
- Water/propylene glycol mixture with corrosion inhibitors for frost protection down to < -20 °C

**7.3 Drainage/cleaning**

	<b>WARNING</b>
	<p><b>Fluids handled, consumables and supplies which are hot and/or pose a health hazard</b></p> <p>Hazard to persons and the environment!</p> <ul style="list-style-type: none"> <li>▷ Collect and properly dispose of flushing fluid and any fluid residues.</li> <li>▷ Wear safety clothing and a protective mask if required.</li> <li>▷ Observe all legal regulations on the disposal of fluids posing a health hazard.</li> </ul>

If the pump set has handled fluids whose residues could lead to corrosion damage in the presence of atmospheric humidity or could ignite upon contact with oxygen, the pump set must be neutralised, and anhydrous inert gas must be blown through the pump to ensure drying.

Use connection 6B to drain the fluid handled (see drawing of auxiliary connections).

**7.4 Dismantling the pump set**

**7.4.1 General information/Safety regulations**

	<b>WARNING</b>
	<p><b>Unqualified personnel performing work on the pump (set)</b></p> <p>Risk of injury!</p> <ul style="list-style-type: none"> <li>▷ Always have repair work and maintenance work performed by specially trained, qualified personnel.</li> </ul>

	<b>WARNING</b>
	<p><b>Improper lifting/moving of heavy assemblies or components</b></p> <p>Personal injury and damage to property!</p> <ul style="list-style-type: none"> <li>▷ Use suitable transport devices, lifting equipment and lifting tackle to move heavy assemblies or components.</li> </ul>

Observe the general safety instructions and information.

For any work on the motor, observe the instructions of the relevant motor manufacturer.

For dismantling and reassembly observe the exploded view and the general assembly drawing.

In case of damage you can always contact our service departments.

2580.815/14-EN

	<b>DANGER</b>
	<p><b>Insufficient preparation of work on the pump (set)</b> Risk of injury!</p> <ul style="list-style-type: none"> <li>▷ Properly shut down the pump set.</li> <li>▷ Close the shut-off elements in the suction line and discharge line.</li> <li>▷ Drain the pump and release the pump pressure. (⇒ Section 7.3, Page 50)</li> <li>▷ Shut off any auxiliary feed lines.</li> <li>▷ Allow the pump set to cool down to ambient temperature.</li> </ul>
	<b>NOTE</b>
	<p>An impeller removal tool is required to remove the impeller.</p>



**7.4.2 Preparations for dismantling**


	<b>DANGER</b>
	<p><b>Insufficient preparation of work on the pump (set)</b> Risk of injury!</p> <ul style="list-style-type: none"> <li>▷ Properly shut down the pump set.</li> <li>▷ Close the shut-off elements in the suction line and discharge line.</li> <li>▷ Drain the pump and release the pump pressure. (⇒ Section 7.3, Page 50)</li> <li>▷ Shut off any auxiliary feed lines.</li> <li>▷ Allow the pump set to cool down to ambient temperature.</li> </ul>
	<b>WARNING</b>
	<p><b>Components with sharp edges</b> Risk of cutting or shearing injuries!</p> <ul style="list-style-type: none"> <li>▷ Always use appropriate caution for installation and dismantling work.</li> <li>▷ Wear work gloves.</li> </ul>
	<b>NOTE</b>
	<p>The pump casing can remain installed in the piping for further dismantling.</p>

1. Disconnect the power supply (e.g. at the motor).
2. Disconnect and remove all auxiliary pipework.
3. Remove coupling guard 681.
4. Remove the coupling spacer of coupling 848, if any.
5. Drain the oil.



### 7.4.3 Separating the pump from the piping



The pump can be dismantled without removing the pump casing from the pipeline.  
Exception: When removing or re-fitting a casing wear ring or wear plate.

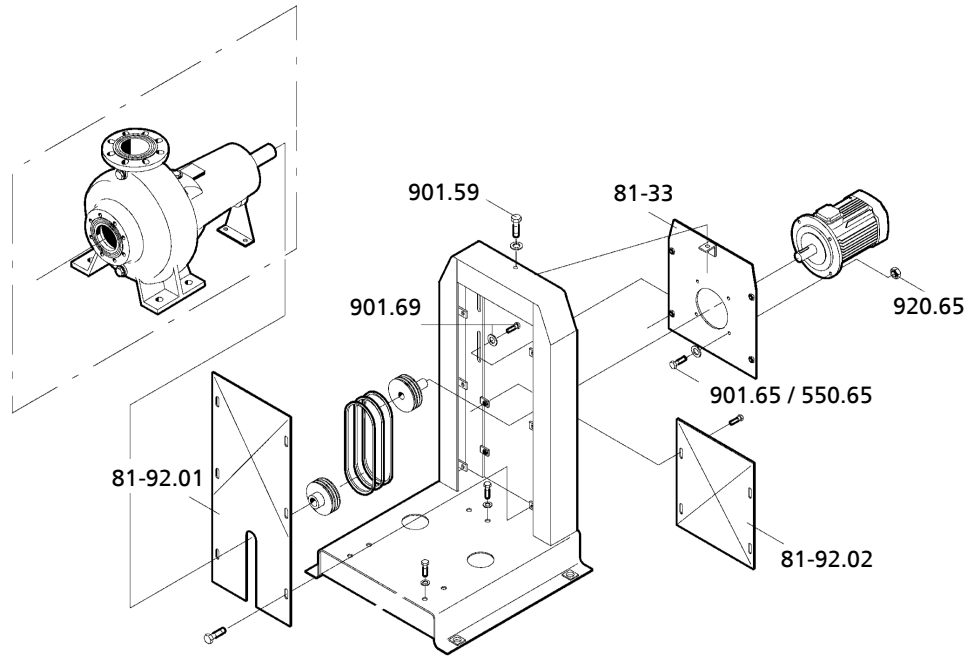
	 <b>DANGER</b>
	<p><b>Insufficient preparation of work on the pump (set)</b> Risk of injury!</p> <ul style="list-style-type: none"> <li>▷ Properly shut down the pump set.</li> <li>▷ Close the shut-off elements in the suction line and discharge line.</li> <li>▷ Drain the pump and release the pump pressure. (⇒ Section 7.3, Page 50)</li> <li>▷ Shut off any auxiliary feed lines.</li> <li>▷ Allow the pump set to cool down to ambient temperature.</li> </ul>

	<b>NOTE</b>
	<p>After the pump set has been dismantled, the suction casing should be cleaned with water. Suitable protective clothing is recommended.</p>

### 7.4.4 Removing the belt drive for installation type 3HZ

	 <b>DANGER</b>
	<p><b>Work in the area of the V-belts</b> Injury by moving parts!</p> <ul style="list-style-type: none"> <li>▷ Make sure that the pump set cannot be switched on.</li> </ul>

	 <b>DANGER</b>
	<p><b>Unsecured dismantled components</b> Injury by falling parts!</p> <ul style="list-style-type: none"> <li>▷ Secure all dismantled components or assemblies against moving or tipping over.</li> </ul>



**Fig. 22:** Removing the belt drive

1. Loosen and remove pump-end and motor-end cover plates 81.92-01 and 81.92-02 from the pulley.
2. Slightly loosen bolt 901.69 at motor plate 81-33.
3. Lower the motor including the motor plate via adjusting screw 901.59 until the V-belt can be removed by hand.
4. If required, remove the pulley.
5. Secure the motor with a lifting rope.  
Use the lifting lug.
6. Completely undo bolts 901.69 and 901.59 at motor plate 81.33 and remove the motor plate with the motor.
7. Undo screwed connections 901.65, 550.65 and 920.65 and remove the motor from the motor plate.

#### 7.4.4.1 Using taper clamping bushes

- ✓ Dismantling steps 1 to 3 have been completed.
  1. Loosen all screws.
  2. Completely undo one or two screws, depending on the bush size. Oil the screw(s) and screw them into the jacking threads.
  3. Tighten the screw(s) evenly until the bush separates from the hub and the disc can be moved freely on the shaft.
  4. Remove the pulley from the shaft together with the bush.

#### 7.4.4.2 Using pulleys to DIN 2211

- ✓ Dismantling steps 1 to 3 have been completed.
  1. Use a puller to remove the pulleys from the shaft.



#### NOTE

The puller is not included in the scope of supply.

### 7.4.5 Removing the back pull-out unit

The steps for dismantling vary depending on the installation type (3E or 3H):

#### For installation type 3E:

- ✓ The lubricant chamber has been drained off all lubricant.
  - ✓ Transport equipment and lifting tackle are available.
  - ✓ An area for the back pull-out unit has been prepared.
1. Remove the coupling guard.
  2. Remove the coupling spacer, if any.
  3. Remove the drive, if required.
  4. Loop a rope tightly around the bearing carrier.
  5. Undo bolts 901.61 and discs 550.61 fastening the support foot.
  6. Undo screwed connections 902.01 and 920.01 and pull the complete back pull-out unit consisting of bearing bracket 330, shaft 210 and impeller 230 out of pump casing 101.
  7. Place the back pull-out unit in a safe and dry installation area and secure it against tipping over or rolling off.

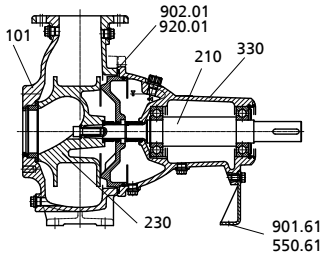


Fig. 23: Removing the back pull-out unit

#### For installation type 3H:

- ✓ The lubricant chamber has been drained off all lubricant.
  - ✓ Transport equipment and lifting tackle are available.
  - ✓ The belt drive has been removed.
  - ✓ An area for the back pull-out unit has been prepared.
1. Loop a rope tightly around the bearing carrier.
  2. Remove the drive and motor stand, if required.
  3. Undo bolts 901.61 and discs 550.61 fastening the support foot.
  4. Undo screwed connections 902.01 and 920.01 and pull the complete back pull-out unit consisting of bearing bracket 330, shaft 210 and impeller 230 out of pump casing 101.
  5. Place the back pull-out unit in a safe and dry installation area and secure it against tipping over or rolling off.

### 7.4.6 Removing an impeller with tapered interference fit

1. Unscrew socket head cap screw 914.10 with disc 550.23.
2. Completely screw the grub screw into the shaft thread.
3. Use a forcing screw to pull off impeller 230.

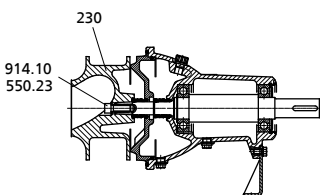


Fig. 24: Removing the impeller

	<b>NOTE</b>
	The forcing screw is not included in the scope of supply. It can be ordered separately from KSB.

Table 19: Forcing screws for pulling off the impeller

Size	Impeller type	Forcing screw (ADS)	
		Thread	Code
050-215	F	M 10	ADS 0
050-216	F	M 10	ADS 0
050-250	F, K	M 16	ADS 1

2580.815/14-EN

Size	Impeller type	Forcing screw (ADS)	
		Thread	Code
050-251	F, K	M 20	ADS 2
065-215	F	M 10	ADS 6
065-216	E	M 12	ADS 7
065-217	F	M 10	ADS 6
065-250	F, K	M 16	ADS 1
065-253	F	M 20	ADS 2
080-215	F	M 10	ADS 6
080-216	F	M 10	ADS 6
080-216	E	M 12	ADS 7
080-217	F	M 10	ADS 6
080-250	F, K	M 16	ADS 1
080-252	F	M 16	ADS 1
080-253	F, E	M 20	ADS 2
080-315	K	M 20	ADS 2
080-315	D	M 20	ADS 4
080-316	D	M 20	ADS 4
080-317	F	M 20	ADS 2
080-317	D	M 20	ADS 4
100-215	F	M 10	ADS 6
100-250	E	M 16	ADS 1
100-251	F	M 20	ADS 2
100-251	D	M 16	ADS 3
100-252	F	M 16	ADS 1
100-253	E, F, K	M 20	ADS 2
100-253	D	M 16	ADS 3
100-254	F, K	M 16	ADS 1
100-315	D	M 20	ADS 4
100-316	F, K	M 20	ADS 2
100-316	D	M 20	ADS 4
100-317	E	M 20	ADS 2
100-400	K	M 20	ADS 5
100-401	E, F, K	M 20	ADS 5
100-403	D	M 24	ADS 5
150-251	D	M 16	ADS 3
150-253	D	M 16	ADS 3
150-315	F	M 20	ADS 2
150-315	D	M 20	ADS 4
150-317	E, K	M 20	ADS 2
150-317	D	M 20	ADS 4
150-400	D	M 24	ADS 5
150-400	K	M 20	ADS 5
150-401	D	M 24	ADS 5
150-401	E, F	M 20	ADS 5
150-403	K	M 24	ADS 5
150-403	D	M 24	ADS 5
151-403	K	M 24	ADS 5
200-315	K	M 20	ADS 2
200-315	D	M 20	ADS 4

Size	Impeller type	Forcing screw (ADS)	
		Thread	Code
200-316	K	M 20	ADS 2
200-317	K	M 20	ADS 2
200-318	K	M 20	ADS 2
200-400	D	M 24	ADS 5
200-402	K	M 20	ADS 5
200-402	D	M 24	ADS 5
200-403	K	M 20	ADS 5
200-405	D	M 24	ADS 5
250-400	D	M 24	ADS 5
250-401	K	M 20	ADS 5
250-402	D	M 24	ADS 5
250-403	K	M 20	ADS 5
300-400	D	M 24	ADS 5
300-400	K	M 20	ADS 5
300-401	K	M 20	ADS 5
300-402	D	M 24	ADS 5

#### 7.4.7 Dismantling the mechanical seal

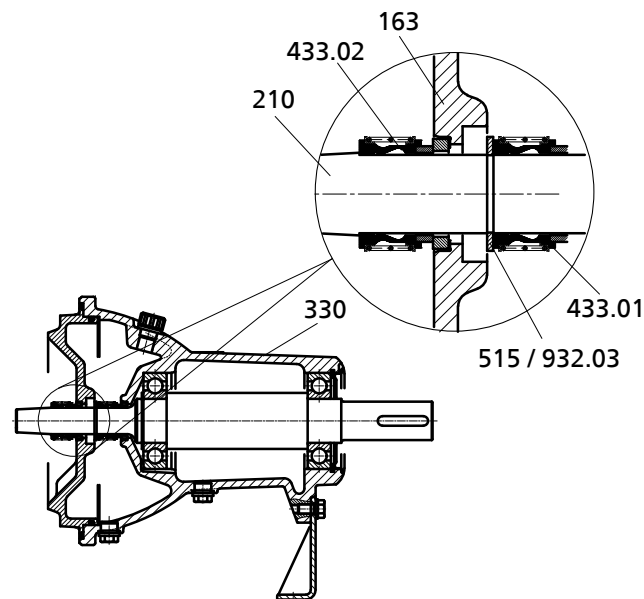


Fig. 25: Dismantling the mechanical seal

##### 7.4.7.1 Dismantling the pump-end mechanical seal

- ✓ The back pull-out unit and the impeller have been removed as described above.
  1. Pull the rotating assembly of mechanical seal 433.01 off shaft 210.
  2. Remove discharge cover 163 from bearing bracket 330.
  3. Press the stationary seat of mechanical seal 433.02 out of discharge cover 163.

##### 7.4.7.2 Dismantling the motor-end mechanical seal

- ✓ The back pull-out unit and the impeller have been removed as described above.
  1. Remove locking ring 515 or circlip 932.03.
  2. Pull the rotating assembly of mechanical seal 433.01 off shaft 210.



### 7.4.7.3 Removing the C022/025/11-4STQ double cartridge seal

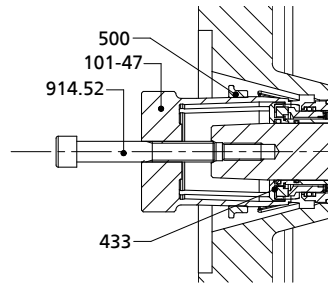


Fig. 26: Removing the C022/025/11-4STQ double cartridge seal

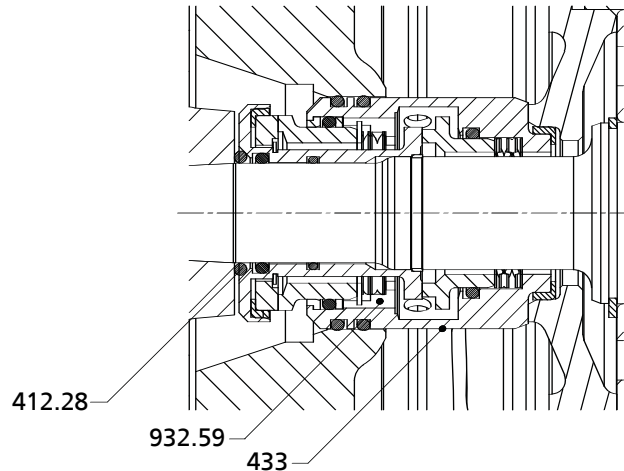


Fig. 27: Removing the mechanical seal

- ✓ The back pull-out unit and the impeller have been removed as described above.
1. Fix discharge cover 163 to bearing bracket 330 using suitable bolts/screws and washers.
  2. Remove O-ring 412.28 from the shaft.
  3. Slide puller 101-47 over the shoulder of mechanical seal 433 and lock with ring 500.
  4. Press forcing screw 914.52 against shaft 210 and pull mechanical seal 433 out of discharge cover 163.

### 7.4.7.4 Removing the C033/055M1-4STQ double cartridge seal

The rules of sound engineering practice and the pump manufacturer's general provisions apply. Tidiness and cleanliness are essential for proper execution of the installation work.

- ✓ The back pull-out unit of the pump has been removed from the pump casing and safely positioned and secured in a horizontal position.
  - ✓ The impeller and keys have been removed from the pump shaft.
1. Remove circlip 932.53 from discharge cover 163.
  2. Use the radial groove in shaft sleeve 523 to remove the mechanical seal cartridge. Remove evenly, using a suitable extraction tool.
  3. Carefully pull the complete cartridge seal off the shaft.
  4. Clean the pump components in the area of the mechanical seal, pump shaft 210, discharge cover 163 and bearing bracket 330. Check for any damage.

Further dismantling of the mechanical seal is carried out at KSB.

7.4.8 Removing shaft and rolling element bearings

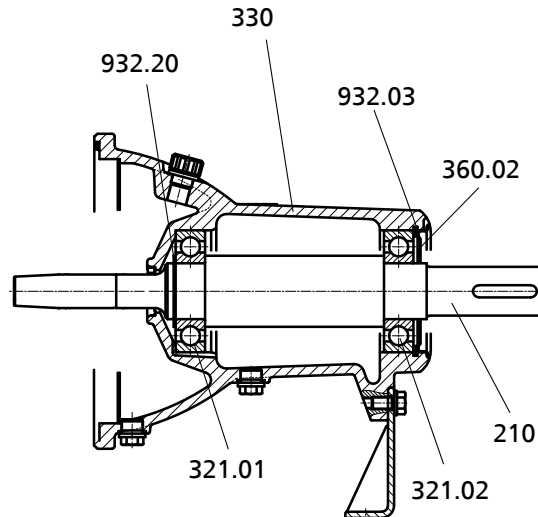
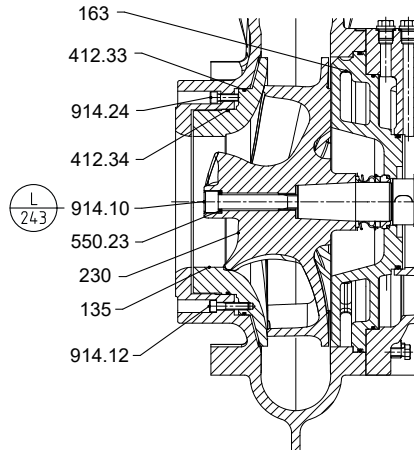


Fig. 28: Removing the shaft and rolling element bearings

- ✓ The back pull-out unit, impeller and mechanical seal have been removed as described.
- 1. Remove cover 360.02 and circlip 932.02.
- 2. Drive shaft 210 with deep groove ball bearings 321.01/02 out of the bearing bracket towards the drive end.
- 3. Remove circlip 932.20.
- 4. Pull deep groove ball bearings 321.01/02 off the shaft.
- 5. Remove the stationary seat of drive-end mechanical seal 433.01 from bearing bracket 330.
- 6. Clean all components and inspect them for signs of wear.

	<b>CAUTION</b>
	<p><b>Re-installing damaged components</b>                  Damage to the machine!</p> <ul style="list-style-type: none"> <li>▷ Re-work damaged components or replace by new ones.</li> </ul>

7.4.9 Removing the wear plate (for D impeller only)



**Fig. 29:** Removing the wear plate

- ✓ The back pull-out unit, the belt drive (if any) and the motor have been properly removed from the pump casing.
- ✓ The inside of the casing has been cleaned.
- ✓ The wear plate needs to be replaced as a result of visual inspection.
  1. Unbolt the pump casing from the piping.
  2. Undo hexagon socket head cap screws 914.12.
  3. Remove wear plate 135.01 and O-rings 412.34.

## 7.5 Reassembling the pump set

### 7.5.1 General information/Safety regulations

	<b>⚠ WARNING</b>
	<p><b>Improper lifting/moving of heavy assemblies or components</b>                  Personal injury and damage to property!</p> <ul style="list-style-type: none"> <li>▸ Use suitable transport devices, lifting equipment and lifting tackle to move heavy assemblies or components.</li> </ul>
	<b>CAUTION</b>
	<p><b>Improper reassembly</b>                  Damage to the pump!</p> <ul style="list-style-type: none"> <li>▸ Reassemble the pump (set) in accordance with the general rules of sound engineering practice.</li> <li>▸ Use original spare parts only.</li> </ul>

**Sequence** Always re-assemble the pump (set) in accordance with the corresponding general assembly drawing and/or exploded view.

**Sealing elements** Check O-rings for any damage and replace by new O-rings if required.  
 Never use O-rings that have been made by cutting an O-ring cord to size and gluing the ends together.

**Assembly aids** Coat the locating surfaces of the individual components and screwed connections with graphite or similar before reassembly.

**Tightening torques** For reassembly, tighten all screws and bolts as specified in this manual. (⇒ Section 7.6, Page 75) (Also see general assembly drawing and data sheet.)

**Bearings** Only use specified bearings to DIN 625 (part Nos. 320.01/02).

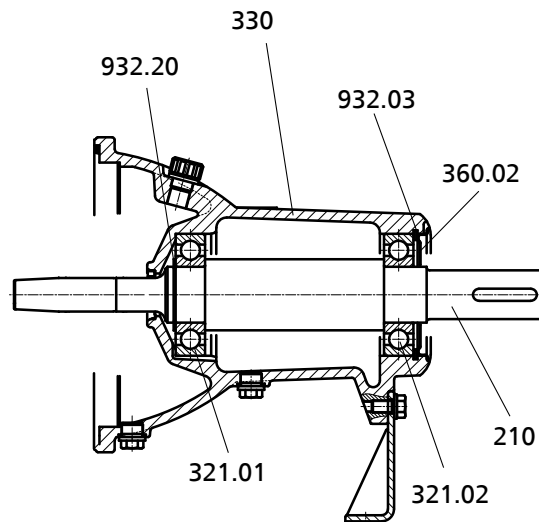
**Table 20:** Bearing assembly

Bearing bracket size	Grease-packed deep groove ball bearings, sealed for life
S01	6307 - 2 Z - C3
S02	6311 - 2 Z - C3
S03	6314 - 2 Z - C3
S04	6314 - 2 Z - C3

**Checking the alignment** After assembly with the pump casing that has remained in the piping, check the coupling alignment. (⇒ Section 5.6, Page 29)

### 7.5.2 Re-installing the shaft and rolling element bearings

When re-installing the shaft, replace deep groove ball bearings 321.01/02, if required. (⇒ Section 7.5.1, Page 60)



**Fig. 30:** Installing the shaft and rolling element bearings

1. Press deep groove ball bearings 321.01/02 onto shaft 210 until they abut against the shaft shoulder.
2. Insert circlip 932.20 into shaft 210.
3. Insert pre-assembled shaft 210 into bearing bracket 330 from the drive end.
4. Press cover 360.02 into the bearing bracket.

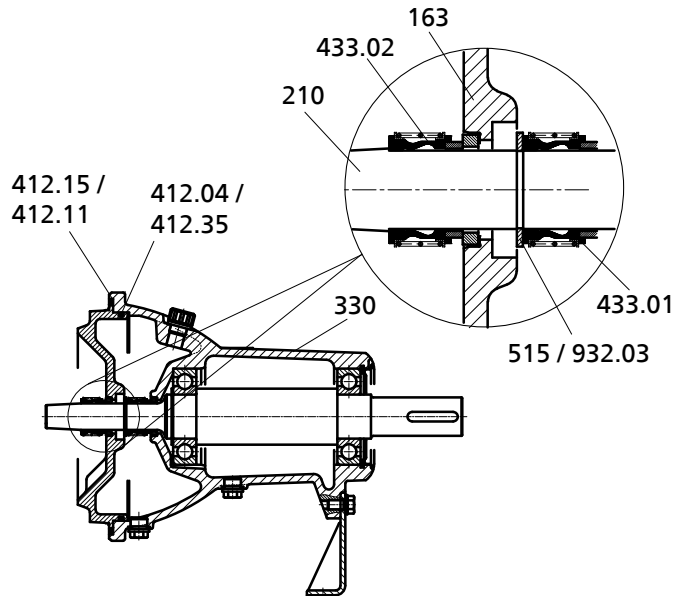
### 7.5.3 Installing the mechanical seal

We recommend always using new original mechanical seals for re-assembly.

**Observe the following to ensure trouble-free operation of the mechanical seal:**

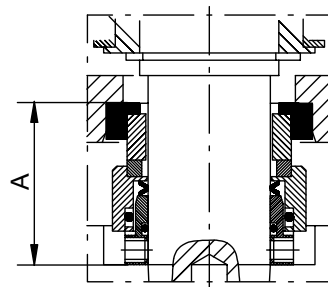
- Only remove the protective wrapping of the seal faces immediately before assembly takes place.
- Make sure the surface of the shaft is absolutely clean and undamaged.
- Immediately before installing the mechanical seal, wet the seal faces with a drop of oil.
- For easier installation of bellows-type mechanical seals, wet the inside diameter of the bellows with soapy water (not oil).
- To prevent any damage to the rubber bellows, place a thin foil (of approximately 0.1 to 0.3 mm thickness) around the free shaft stub. Slide the rotating assembly over the foil into its installation position. Then remove the foil.

## 7.5.3.1 Installing the bellows-type mechanical seal


**Fig. 31:** Installing the mechanical seals

- ✓ The shaft and rolling element bearings have been properly installed in the bearing bracket.
1. Slide drive-end mechanical seal 433.01 onto shaft 210 and secure it with locking ring 515 or circlip 932.03.
  2. Insert O-rings 412.04/412.35 and 412.15/412.11 into discharge cover 163, and press them into bearing bracket 330 as far as they will go.
  3. Slide pump-end mechanical seal 433.02 onto shaft 210.

For special mechanical seals with covered spring, tighten the socket head cap screw at the rotating assembly before fitting the impeller. Observe installation dimension "A".


**Fig. 32:** Installation dimension "A"

**Table 21:** Installation dimension "A" [mm]

Size	Impeller type	Installation dimension "A" [mm]
050 - 215	F	29,0
050 - 216	F	29,0
050 - 250	F, K	29,0
050 - 251	F, K	38,5
065 - 215	F	29,0
065 - 216	E	38,5
065 - 217	F	29,0
065 - 250	F, K	29,0
065 - 253	F	38,5
080 - 215	F	29,0

Size	Impeller type	Installation dimension "A" [mm]
080 - 216	F	29,0
080 - 216	E	38,5
080 - 217	F	29,0
080 - 250	F, K	29,0
080 - 252	F	29,0
080 - 253	E, F	38,5
080 - 315	K	38,5
080 - 315	D	38,5
080 - 316	D	38,5
080 - 317	D, F	38,5
100 - 215	F	29,0
100 - 250	E	29,0
100 - 251	F	38,5
100 - 251	D	38,5
100 - 252	F	29,0
100 - 253	D, E, F, K	38,5
100 - 254	F, K	29,0
100 - 315	D	38,5
100 - 316	K, F, D	38,5
100 - 317	E	38,5
100 - 400	K	48,3
100 - 401	K	48,3
100 - 403	D	48,3
150 - 251	D	38,5
150 - 253	D	38,5
150 - 315	D, F	38,5
150 - 317	E, D, K	38,5
150 - 400	K	48,3
150 - 401	E, F	48,3
150 - 403	K, D	48,3
200 - 315	D, K	38,5
200 - 316	K	38,5
200 - 317	K	38,5
200 - 318	K	38,5
200 - 402	K, D	48,3
200 - 403	K	48,3
200 - 405	D	48,3
250 - 401	K	48,3
250 - 402	D	48,3
250 - 403	K	48,3
300 - 400	K	48,3
300 - 401	K	48,3
300 - 402	D	48,3

7.5.3.2 Installing the C022/025M1-4STQ double cartridge seal

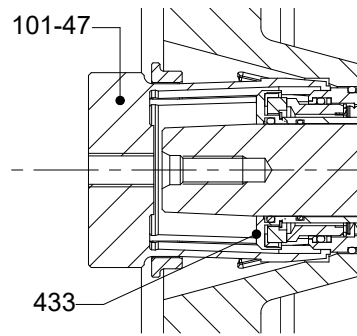


Fig. 33: Installing the C022/025M1-4STQ double cartridge seal

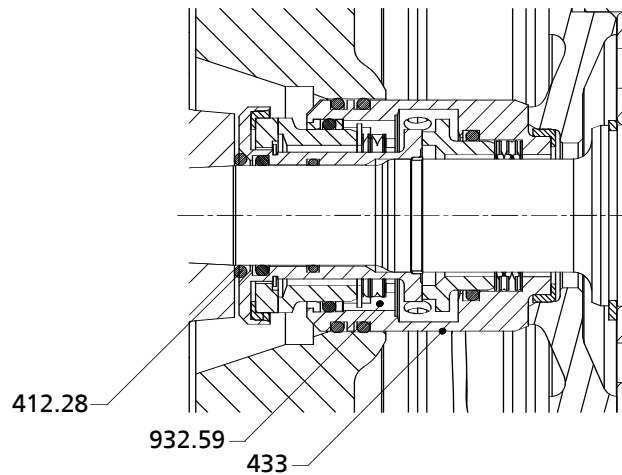



Fig. 34: Installing the mechanical seal

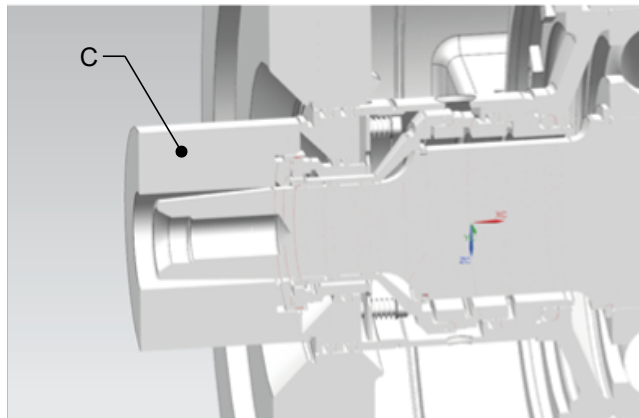
- ✓ The installation of the mechanical seal is carried out in accordance with the installation drawing.
  - ✓ The back pull-out unit of the pump has been placed in a clean and level assembly area.
  - ✓ The KSB 4STQ double cartridge seal is fully assembled and undamaged.
1. Insert circlip 932.59 in the shaft groove and make sure that circlip 932.59 is positioned correctly in the shaft groove. When fitting the circlip take care to prevent damage to the shaft.

	<p style="background-color: yellow; margin: 0;"><b>CAUTION</b></p> <p><b>Use of grease or other permanent lubricants</b> Torque transmission impeded / overheating of and damage to the pump!</p> <ul style="list-style-type: none"> <li>▷ Never use grease or other permanent lubricants for fitting the torque-transmitting elements of a mechanical seal.</li> <li>▷ Use soft soap to reduce any friction caused during assembly.</li> <li>▷ Never coat the mechanical seal faces with grease or oil.</li> </ul>
--	---

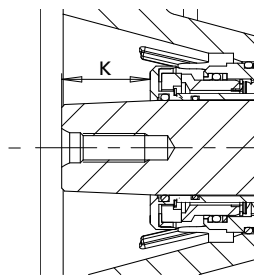


	<b>CAUTION</b>
	<p><b>Improper installation of the mechanical seal</b>                  Damage to the seal faces!</p> <ul style="list-style-type: none"> <li>▷ Install the mechanical seal using the supplied mounting device 101-47.</li> <li>▷ Prevent sudden forces acting on the mounting device and mechanical seal.</li> </ul>

2. Prior to assembly, wet the external elastomers (O-rings and gasket) and the seats of the mechanical seal at the shaft, discharge cover 163 and seal housing with a suitable lubricant (e.g. soap suds).
3. Press mechanical seal 433 into discharge cover 163 by hand as far as possible.
4. Fit mechanical seal 433 using mounting device 101-47. Check the mechanical seal position against reference dimensions "K" (see table: Reference dimension "K") and correct the installation position if required.
5. Slide O-ring 412.28 over shaft, until it abuts against the mechanical seal.



**Fig. 35:** Mounting device 101-47



**Fig. 36:** Reference dimension "K" from shaft end to KSB double cartridge seal

**Table 22:** Reference dimension "K"

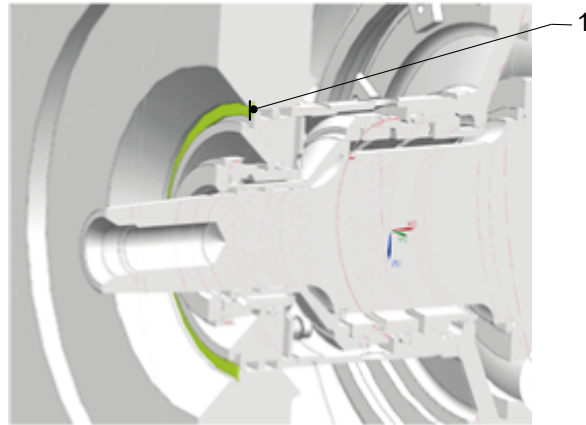
Size	Reference dimension "K"
50-215/216 65-215/217 80-215/217, F 80-216 100-215	25 +/- 0,5
65-216 E 80-216	33 +/- 0,5

Size	Reference dimension "K"
50-250 65-250/252 80-250/252 100-250/252/254	39 +/- 0,5
50-251 65-253 80-253/315/316/317 100-251/253/315/316/317 150-315/317 200-315/316/317/318	43 +/- 0,5

7.5.3.3 Installing the C033/055M1-4STQ double cartridge seal

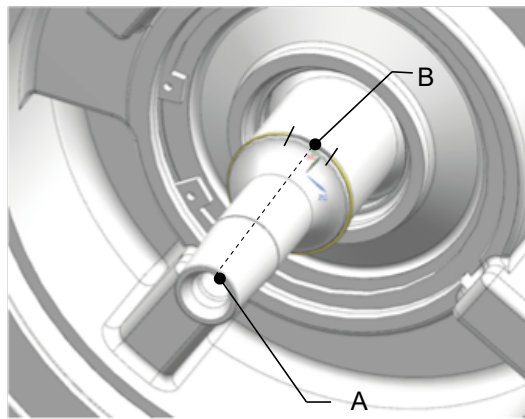
	<p><b>! WARNING</b></p>
	<p><b>Components with sharp edges</b> Risk of cutting or shearing injuries!</p> <ul style="list-style-type: none"> <li>▸ Always use appropriate caution for installation and dismantling work.</li> <li>▸ Wear work gloves.</li> </ul>
	<p><b>CAUTION</b></p>
	<p><b>Use of grease or other permanent lubricants</b> Torque transmission impeded / overheating of and damage to the pump!</p> <ul style="list-style-type: none"> <li>▸ Never use grease or other permanent lubricants for fitting the torque-transmitting elements of a mechanical seal.</li> <li>▸ Use soft soap to reduce any friction caused during assembly.</li> <li>▸ Never coat the mechanical seal faces with grease or oil.</li> </ul>
	<p><b>CAUTION</b></p>
	<p><b>Improper installation of the mechanical seal</b> Damage to the seal faces!</p> <ul style="list-style-type: none"> <li>▸ Install the mechanical seal using the supplied mounting device C.</li> <li>▸ Prevent sudden forces acting on the mounting device and mechanical seal.</li> </ul>

- ✓ The relevant documentation for installing the mechanical seal is observed.
  - ✓ The back pull-out unit has been removed from the pump casing and safely positioned and secured in a horizontal position.
  - ✓ The original 4STQ cartridge seal is fully assembled and undamaged.
  - ✓ Mounting device C is available.
1. Guide the mechanical seal (without external O-rings) onto the shaft as far as it will go.



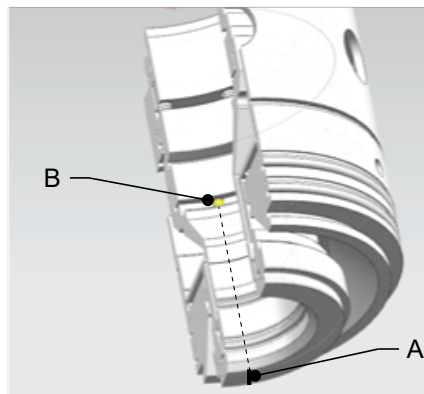
**Fig. 37:** Illustration of the groove

2. Visually check that the groove for the circlip in discharge cover 1 aligns with the corresponding surface of the mechanical seal (seal housing).
3. Pull the mechanical seal off the shaft.
4. Fit the circlip in the shaft groove.



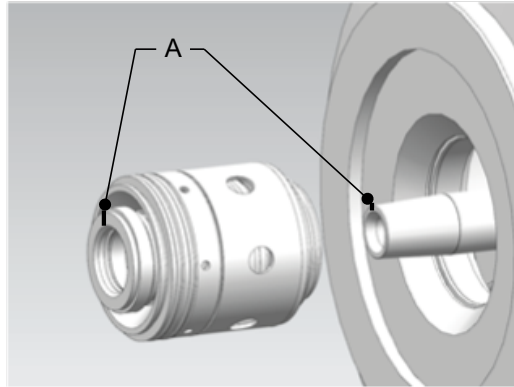
**Fig. 38:** Marking the shaft end

5. Mark the front face of shaft end A. To do so extend the central position of ring opening B in the axial direction.



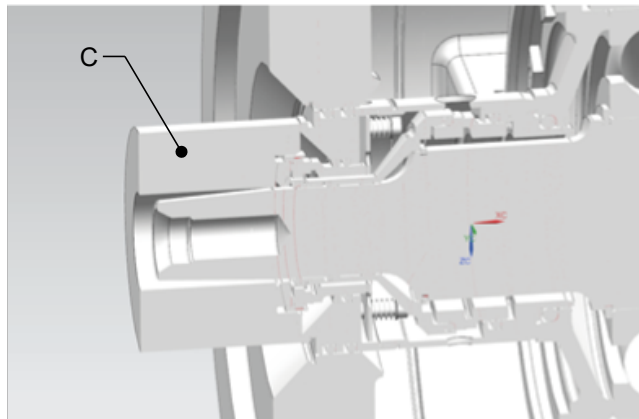
**Fig. 39:** Marking the mechanical seal

6. Mark the front face of mechanical seal A. To do so extend the position of the anti-rotation pin B in the axial direction.
7. Fit the external O-rings and wet them with a suitable lubricant (e.g. soap solution).

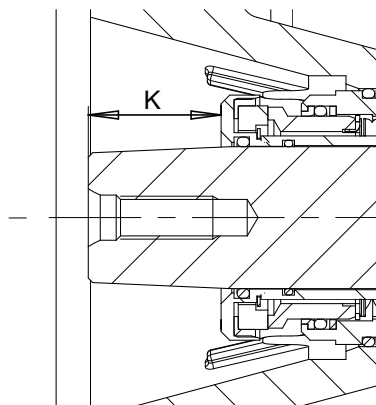


**Fig. 40:** Aligning the markings

8. Place the mechanical seal on the shaft. Guide it as far into the discharge cover as possible. Verify that the markings A are aligned with each other.

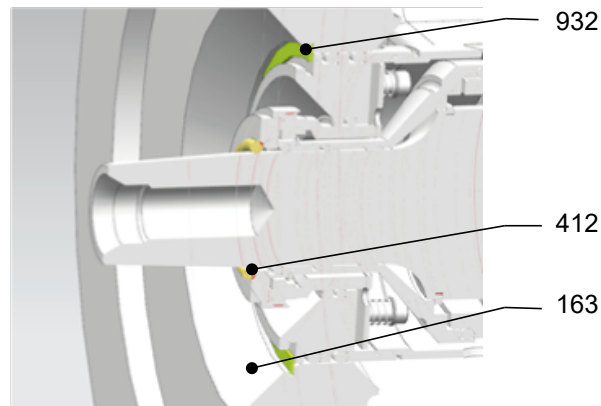


**Fig. 41:** Mounting device C



**Fig. 42:** Reference dimension "K" from shaft end to mechanical seal

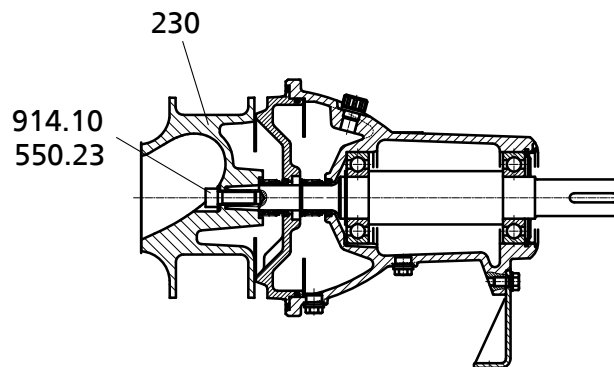
- Position mounting device C on the front face of the mechanical seal. Fit the mechanical seal. Verify the position of the mechanical seal with reference dimension "K" = 43+/- 0.5 mm; adjust the position if necessary.



**Fig. 43: Final assembly**

- Fit circlip 932 in the groove of discharge cover 163. Make sure it is correctly seated.
- Slide O-ring 412 over the shaft until it abuts against the mechanical seal.

**7.5.4 Fitting the impeller**



**Fig. 44: Fitting the impeller**

- ✓ The shaft and rolling element bearings have been properly installed.
  - ✓ The mechanical seals have been properly installed.
- Slide impeller 230 onto the shaft end.
  - Screw in impeller screw 914.10 and disc 550.23. Tighten them with a torque wrench.

	<b>NOTE</b>
	On shafts without a Helicoil thread insert secure the impeller screw with Loctite 243.

**Table 23: Tightening torque for impeller screw [Nm]**

Size	Impeller type	Thread	Tightening torque [Nm]
050 - 215	F	M 8	26
050 - 216	F	M 8	26
050 - 250	F, K	M 10	35
050 - 251	F, K	M 16	150
065 - 215	F	M 8	26

Size	Impeller type	Thread	Tightening torque [Nm]
065 - 216	E	M 10	35
065 - 217	F	M 8	26
065 - 250	F, K	M 10	35
065 - 253	F	M 16	150
080 - 215	F	M 8	26
080 - 216	F	M 8	26
080 - 216	E	M 10	35
080 - 217	F	M 8	26
080 - 250	F, K	M 10	35
080 - 252	F	M 10	35
080 - 253	E, F	M 16	150
080 - 315	D, K	M 16	150
080 - 316	D	M 16	150
080 - 317	D, F	M 16	150
100 - 215	F	M 8	26
100 - 250	E	M 10	35
100 - 251	F	M 16	150
100 - 251	D	M 10	35
100 - 252	F	M 10	35
100 - 253	D, E, F, K	M 10	35
100 - 254	F, K	M 10	35
100 - 315	D	M 16	150
100 - 316	D, F, K	M 16	150
100 - 317	E	M 16	150
100 - 400	K	M 20	290
100 - 401	K	M 20	290
100 - 403	D	M 20	290
150 - 251	D	M 16	150
150 - 253	D	M 16	150
150 - 315	D, F	M 16	150
150 - 317	E, D, K	M 16	150
150 - 400	K	M 20	290
150 - 401	E, F, D	M 20	290
150 - 403	K	M 20	290
200 - 315	D, K	M 16	150
200 - 316	K	M 16	150
200 - 317	K	M 16	150
200 - 318	K	M 16	150
200 - 402	K, D	M 20	290
200 - 403	K	M 20	290
200 - 405	D	M 20	290
250 - 401	K	M 20	290
250 - 402	D	M 20	290
250 - 403	K	M 20	290
300 - 400	K	M 20	290
300 - 401	K	M 20	290
300 - 402	D	M 20	290

**Note:**

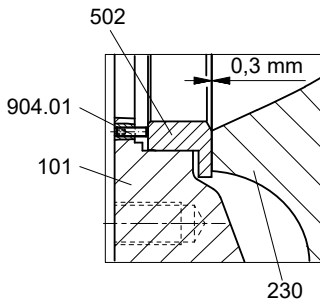
Make sure that the tapered fit of impeller and shaft is undamaged and assembled free from grease.  
 For size Sewatec D 150-251 first screw screwed coupling 852 into the shaft.

**7.5.5 Installing the back pull-out unit**

	<p><b>! WARNING</b></p>
	<p><b>Back pull-out unit tilting</b>                  Risk of crushing hands and feet!                  ▷ Suspend or support the bearing bracket at the pump end.</p>

**Version with adjustable casing wear ring (for sizes E 100-250, E 100-253, E 100-317, E 150-317, K 100-253, K 100-254, K 100-316)**

- ✓ The shaft, rolling element bearings, mechanical seal and impeller have been assembled properly.
- ✓ For back pull-out units without coupling, fit the coupling in accordance with the manufacturer's instructions.



**Fig. 45:** Fitting the casing wear ring

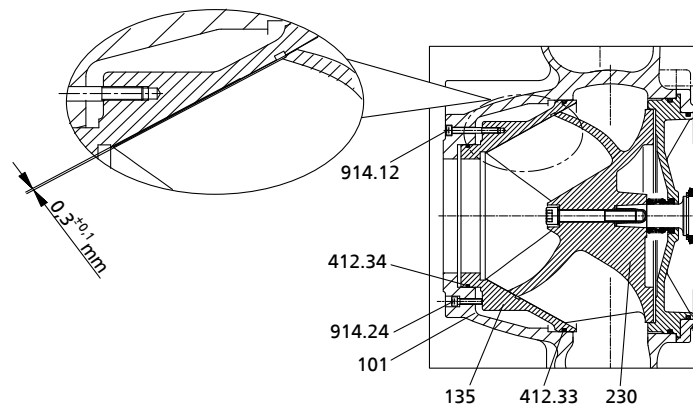
1. Insert casing wear ring 502 into pump casing 101.
2. Glue 3 pieces of cardboard<sup>9)</sup> of approximately 2 mm in thickness and 15 mm in length to the front face of the impeller.  
 ⇒ In assembled condition, this will result in a clearance of 0.3 mm between impeller and casing wear ring.
3. Insert the complete back pull-out unit into the pump casing.
4. Screw in grub screws 904.01, lock the casing wear ring in position.
5. Secure grub screws 904.01 with Loctite.
6. Evenly tighten screwed connection 920.01 between pump casing and bearing bracket.
7. Fasten the support foot to the baseplate with bolts 901.61 and discs 550.61.

	<p><b>NOTE</b></p>
	<p>Only adjust the clearance gap for bearing brackets S01, S02 and S03. Bearing bracket S04 has a radial clearance.</p>

**Version with wear plate (for D impellers only)**

- ✓ The shaft, rolling element bearings, mechanical seal and impeller have been assembled properly.
- ✓ The pump casing is not connected to the piping.

<sup>9</sup> Use cardboard which easily dissolves in water.



**Fig. 46:** Fitting the wear plate

1. Equip wear plate 135 with two new O-rings 412.33 and 412.34.
2. Insert wear plate 135 into pump casing 101.
3. Fasten wear plate 135 to pump casing 101 with hexagon socket head cap screws 914.12.
4. Adjust the clearance between impeller 230 and wear plate 135 by tightening and loosening screws 914.12 and 914.24.
  - ⇒ Screw 914.24 presses the wear plate in the direction of the impeller.
  - ⇒ The clearance equals  $0.3^{\pm 0.1}$  mm (measured on the suction side from the outer surface of the impeller vane to the wear plate).
5. Insert the complete back pull-out unit into the pump casing.
6. Evenly tighten screwed connection 920.01 between pump casing and bearing bracket.
7. Fasten the support foot to the baseplate with bolts 901.61 and discs 550.61.

### 7.5.6 Leak test


After reassembly of the pump, subject the mechanical seal area/lubricant reservoir to a leak test.

1. Tightly screw the testing device into the filler opening (auxiliary connection 13D). (⇒ Section 5.5, Page 28)
2. Test medium: Compressed air  
 Test pressure: Max. 0.8 bar  
 Test period: 2 min
  - ⇒ The pressure must not drop during the test period.
  - ⇒ If the pressure does drop, check the seals and screwed connections. Then perform another leak test.
3. Once the leak test has been successful, fill in the lubricant.  
 (⇒ Section 7.2.3.2, Page 47)




### 7.5.7 Mounting the motor

#### Version with coupling

	<b>NOTE</b>
	Steps 1 and 2 do not apply to versions with spacer-type coupling.


1. Shift the motor to connect it to the pump via the coupling.
2. Fasten the motor to the baseplate.
3. Align the pump and motor. (⇒ Section 5.8, Page 33)
4. Connect the motor to the power supply (refer to manufacturer's product literature).


#### Version with belt drive

	<b>! WARNING</b>
	<p><b>Motor tipping over</b> Risk of squashing hands and feet!</p> <ul style="list-style-type: none"> <li>▷ Suspend or support the motor to prevent it from tipping over.</li> </ul>

1. Fasten the motor to motor plate 81-33 with bolts 901.65, discs 550.65 and nuts 920.65.
2. Screw motor plate 81-33 including motor to motor bracket 890.
3. Screw in height-adjusting elements 901.59 / 550.59.
4. Mount motor bracket 890 on baseplate.

### 7.5.8 Fitting the belt drive

	<b>CAUTION</b>
	<p><b>V-belts pulled on with force</b> Damage to the V-belts! Reduced service life of V-belts!</p> <ul style="list-style-type: none"> <li>▷ Only pull on V-belts if this is possible without using any force.</li> <li>▷ Only pull on V-belts by hand. Do not use any tools (e.g. levers).</li> </ul>

	<b>CAUTION</b>
	<p><b>Multiple V-belt drives</b> Reduced service life of the V-belts!</p> <ul style="list-style-type: none"> <li>▷ Always replace the complete set of V-belts if individual belts are worn.</li> <li>▷ Use V-belts of the same length.</li> </ul>

- ✓ The V-belts are free from burs, rust and dirt.
  - ✓ The motor has been mounted on the motor plate or motor bracket as specified.
  - ✓ The pump has been assembled as specified.
1. Use bushing 540.03 to fit pulley 882.02 on the motor shaft.
  2. Fit bushing 540.02 on pump shaft 210.
  3. Place pulley 882.01 on bushing 540.02.
  4. Pull V-belts on pulleys 882.01/882.02.
  5. Check the alignment of the pulleys.
  6. Tension the V-belts. (⇒ Section 5.7.2, Page 32)

	<b>CAUTION</b>
	<p><b>Swelling of V-belts due to aggressive ambient conditions</b>                  Reduced service life of V-belts!</p> <p>▷ Protect V-belts suitably from oil mist, dripping oil and other chemical influences.</p>

### 7.5.8.1 Using taper clamping bushes

- ✓ All bright (machined) surfaces, such as the drilled holes and the tapered sleeve of the taper clamping bush as well as the tapered drilled hole in the disc have been cleaned and degreased.
1. Insert the taper clamping bush into the hub and align all connection holes.
    - ⇒ Make sure all half threaded holes are matched with half unthreaded holes.
  2. Lightly oil grub screws (sizes 1008 - 3030) or socket head cap screws (sizes 3535 - 5050) and screw them in. Do not tighten the screws at this stage.
  3. Clean and degrease the shaft. Slide the disc with the taper clamping bush onto the shaft until it reaches the required position.
  4. If using a key, first insert this key into the keyway of the shaft. Make sure there is a clearance gap between the key and the drilled keyway.
  5. Evenly tighten the grub screws or socket head cap screws.
  6. Check the tightening torque of the screws after 1/2 to 1 hour. Re-adjust the tightening torque, if required.

**Table 24:** Tightening torque for taper clamping bushes

Bush	Tightening torque	Screws	
	[Nm]	Quantity	Size
1004 / 1108	5,6	2	1/4" BSW
1310 / 1315	20	2	3/8" BSW
1210 / 1215	20	2	3/8" BSW
1610 / 1615	20	2	3/8" BSW
2012	31	2	7/16" BSW
2517	48	2	1/2" BSW
3020 / 3030	90	2	5/8" BSW
3535	112	3	1/2" BSW
4040	170	3	5/8" BSW
4545	192	3	3/4" BSW
5050	271	3	7/8" BSW

	<b>NOTE</b>
	Fill any open connection holes with grease to prevent the ingress of foreign matter.

### 7.5.8.2 Using pulleys to DIN 2211

- Use a pneumatic or hydraulic puller to fit the pulleys.
- Watch the position of the key.
- Secure the pulley axially with a grub screw.

## 7.6 Tightening torques

### 7.6.1 Tightening torques for the pump set

**Table 25:** Tightening torques for the pump set [Nm]

Thread	(A4-70 / 1.4462)
M 6	7
M 8	17
M 10	35
M 12	60
M 16	150
M 20	290
M 24	278 / 500
M 27	409 / 736
M 30	554 / 1000

## 7.7 Spare parts stock

### 7.7.1 Ordering spare parts

Always quote the following data when ordering replacement or spare parts:

- Order number
- Order item number
- Consecutive number
- Type series
- Size
- Material variant
- Seal code
- Year of construction

Refer to the name plate for all data.

Also specify the following data:

- Part No. and description (⇒ Section 9.3, Page 81)
- Quantity of spare parts
- Shipping address
- Mode of dispatch (freight, mail, express freight, air freight)

## 7.7.2 Recommended spare parts stock for 2 years' operation to DIN 24296

Table 26: Quantity of spare parts for recommended spare parts stock

Part No.	Description	Number of pumps (including stand-by pumps)								Spare part	Replacement part	Wear part
		1	2	3	4	5	6	8	10 and more			
135	Wear plate	1	2	2	2	3	3	4	50 %	-	-	✗
163	Discharge cover	1	2	2	2	3	3	4	50 %	✗	-	-
210	Shaft	1	1	1	2	2	2	3	30 %	✗	-	-
230	Impeller	1	1	1	2	2	2	3	30 %	-	✗	-
321.01/02	Rolling element bearing (set)	1	1	1	2	2	3	4	50 %	-	-	✗
330	Bearing bracket, complete	-	-	-	-	-	-	1	2 pcs.	✗	-	-
433.01/02	Mechanical seal, complete (set)	1	2	3	4	4	4	6	90 %	-	-	✗
502.01	Casing wear ring	1	2	2	2	3	3	4	50 %	-	-	✗
503	Impeller wear ring	1	2	2	2	3	3	4	50 %	-	-	✗
	Assembly for gland packing consisting of: ▪ Neck bush ▪ Shaft protecting sleeve ▪ Lantern ring	1	1	1	2	2	2	3	40 %	-	✗	-
	Packing cord (4 rings)	4	4	6	8	8	9	12	100 %	-	-	✗
	Sealing elements (set)	2	4	6	8	8	9	12	150 %	-	-	✗

Keeping a stock of wear parts and replacement parts is recommended also during the warranty period.

## 8 Trouble-shooting

	<b>WARNING</b>
	<p><b>Improper work to remedy faults</b> Risk of injury!</p> <p>▷ For any work performed to remedy faults, observe the relevant information given in this operating manual and/or in the product literature provided by the accessories manufacturer.</p>

If problems occur that are not described in the following table, consultation with the KSB service is required.

- A Pump delivers insufficient flow rate
- B Motor is overloaded
- C Excessive discharge pressure
- D Increased bearing temperature
- E Leakage at the pump
- F Excessive leakage at the shaft seal
- G Vibrations during pump operation
- H Impermissible temperature increase in the pump

Table 27: Trouble-shooting

A	B	C	D	E	F	G	H	Possible cause	Remedy <sup>10)</sup>
X	-	-	-	-	-	-	-	Pump delivers against an excessively high pressure.	Re-adjust to duty point. Check system for impurities. Increase speed.
X	-	-	-	-	-	X	X	Pump and/or piping are not completely vented or primed.	Vent and/or prime.
X	-	-	-	-	-	-	-	Supply line or impeller clogged	Remove deposits in the pump and/or piping.
X	-	-	-	-	-	-	-	Formation of air pockets in the piping	Alter piping layout. Fit vent valve.
-	-	-	X	-	X	X	-	Pump is warped or sympathetic vibrations in the piping.	Check the piping connections and secure fixing of pump; if required, reduce distances between the pipe clamps. Fix the pipelines using anti-vibration material.
X	-	-	-	-	-	X	X	Suction head is too high/NPSH <sub>available</sub> (positive suction head) is too low.	Check/alter fluid level. Fully open the shut-off element in the supply line. Change suction line, if the friction losses in the suction line are too high. Check any strainers installed/suction opening. Observe permissible speed of pressure fall.
-	-	-	X	-	-	-	-	Increased axial thrust	Contact KSB.
X	-	-	-	-	-	-	-	Air intake at the shaft seal	Fit new shaft seal.
X	-	-	-	-	-	-	-	Wrong direction of rotation	Interchange two of the phases of the power cable.
X	X	-	-	-	-	-	-	Motor is running on 2 phases only.	Replace the defective fuse. Check the electric cable connections.
X	-	-	-	-	-	-	-	Speed is too low.	Increase speed, request particulars.
-	-	-	-	-	-	X	-	Defective bearing(s)	Replace bearing(s).
-	-	-	X	-	-	X	X	Insufficient flow rate	Increase the minimum flow rate.
X	-	-	-	-	-	X	-	Wear of internal components	Replace worn components by new ones.

2580.815/14-EN

<sup>10)</sup> Pump pressure must be released before attempting to remedy faults on parts which are subjected to pressure.

A	B	C	D	E	F	G	H	Possible cause	Remedy <sup>10)</sup>
-	X	-	-	-	-	X	-	Pump back pressure is lower than specified in the purchase order.	Re-adjust to duty point.
-	X	-	-	-	-	-	-	Density or viscosity of the fluid handled is higher than stated in the purchase order.	Contact KSB.
-	X	X	-	-	-	-	-	Speed is too high.	Reduce speed, request particulars.
-	-	-	-	X	-	-	-	Assembly bolts/sealing elements	Re-tighten bolts. Fit new sealing elements.
-	-	-	-	-	X	-	-	Worn shaft seal	Fit new shaft seal.
-	-	-	-	-	-	X	-	Vibrations during pump operation	Correct the suction conditions. Re-align the pump. Re-balance the impeller. Increase pressure at the pump suction nozzle.
-	-	-	X	-	X	X	-	The pump set is misaligned.	Check the coupling/belt drive. Re-align, if required.
-	-	-	X	-	-	-	-	Non-compliance with specified coupling distance	Correct the distance according to general arrangement drawing.
-	X	-	-	-	-	-	-	Operating voltage too low.	Increase the voltage.

## 9 Related Documents

### 9.1 Speed adjustment

If the speed needs to be adjusted, the pulleys may only be changed within the limits specified for the pulley dimensions and the centreline distances between pump and motor shaft. If the moment of inertia needs to be increased, a flywheel can be fitted to the motor as an addition. In this case, select a motor with reinforced bearings.

### 9.2 Mass moments of inertia

**Table 28:** Mass moments of inertia and mass details of pulleys in GG

Pulley width						Pulley diameter	n <sub>max. dyn. balanced</sub> [rpm]
50 mm		80 mm		100 mm			
I [kgm <sup>2</sup> ]	m [kg]	I [kgm <sup>2</sup> ]	m [kg]	I [kgm <sup>2</sup> ]	m [kg]	d [mm]	
0,012	5	0,022	9	0,027	11	140	3000
0,017	6	0,028	10	0,034	12	150	3000
0,022	7	0,035	11	0,045	14	160	3000
0,036	9	0,057	14	0,073	18	180	3000
0,055	11	0,09	18	0,11	22	200	3000
0,088	14	0,14	22	0,18	28	224	3000
0,13	17	0,22	28	0,28	36	250	3000
0,22	22	0,35	36	0,44	45	280	2700
0,35	28	0,56	45	0,69	56	315	2700
0,57	36	0,89	57	1,13	72	355	2200
0,92	46	1,46	73	1,82	91	400	1900
1,46	58	2,34	92,8	2,92	116	450	1700
2,23	72	3,56	115	4,45	143	500	1500
3,5	90	5,61	144	7,01	180	560	1350

**Table 29:** Mass moments of inertia and mass details of pulleys with taper clamping bushes

Pulley width				Pulley diameter	n <sub>max. dyn. balanced</sub> [rpm]
50 mm (SPA - 3 grooves)		100 mm (SPA - 5 grooves)			
I [kgm <sup>2</sup> ] <sup>11)</sup>	m [kg] <sup>11)</sup>	I [kgm <sup>2</sup> ] <sup>11)</sup>	m [kg] <sup>11)</sup>	d [mm]	
0,0024	1,4	--	--	100	3000
0,0029	1,6	--	--	106	3000
0,0038	1,6	--	--	112	3000
0,0048	1,9	--	--	118	3000
0,0059	2,3	--	--	125	3000
0,0075	2,6	0,014	4,0	132	3000
0,0097	2,9	0,017	5,2	140	3000
0,013	3,6	0,021	5,9	150	3000
0,018	4,4	0,028	6,8	160	3000
--	--	0,034	7	170	3000
0,030	6,1	0,044	8	180	3000
--	--	0,055	9,3	190	3000
0,034	5,5	0,07	10,5	200	3000
--	--	0,089	12,2	212	3000
0,048	6,2	0,11	14	224	3000
--	--	0,17	19,5	236	3000

Pulley width				Pulley diameter	n <sub>max. dyn. balanced</sub>
50 mm (SPA - 3 grooves)		100 mm (SPA - 5 grooves)			
l [kgm <sup>2</sup> ] <sup>11)</sup>	m [kg] <sup>11)</sup>	l [kgm <sup>2</sup> ] <sup>11)</sup>	m [kg] <sup>11)</sup>	d [mm]	[rpm]
0,068	6,8	0,21	22,5	250	3000
0,097	7,6	0,23	21	280	2700
0,16	11	0,34	24	315	2700
0,163	12	0,48	25,5	335	2200
0,244	13	0,57	31,5	400	1900

---

<sup>11)</sup> Without locking sleeve



9.3 General assembly drawings/exploded views with list of components

9.3.1 General assembly drawing – Sewatec with bearing brackets S01, S02, S03, S04

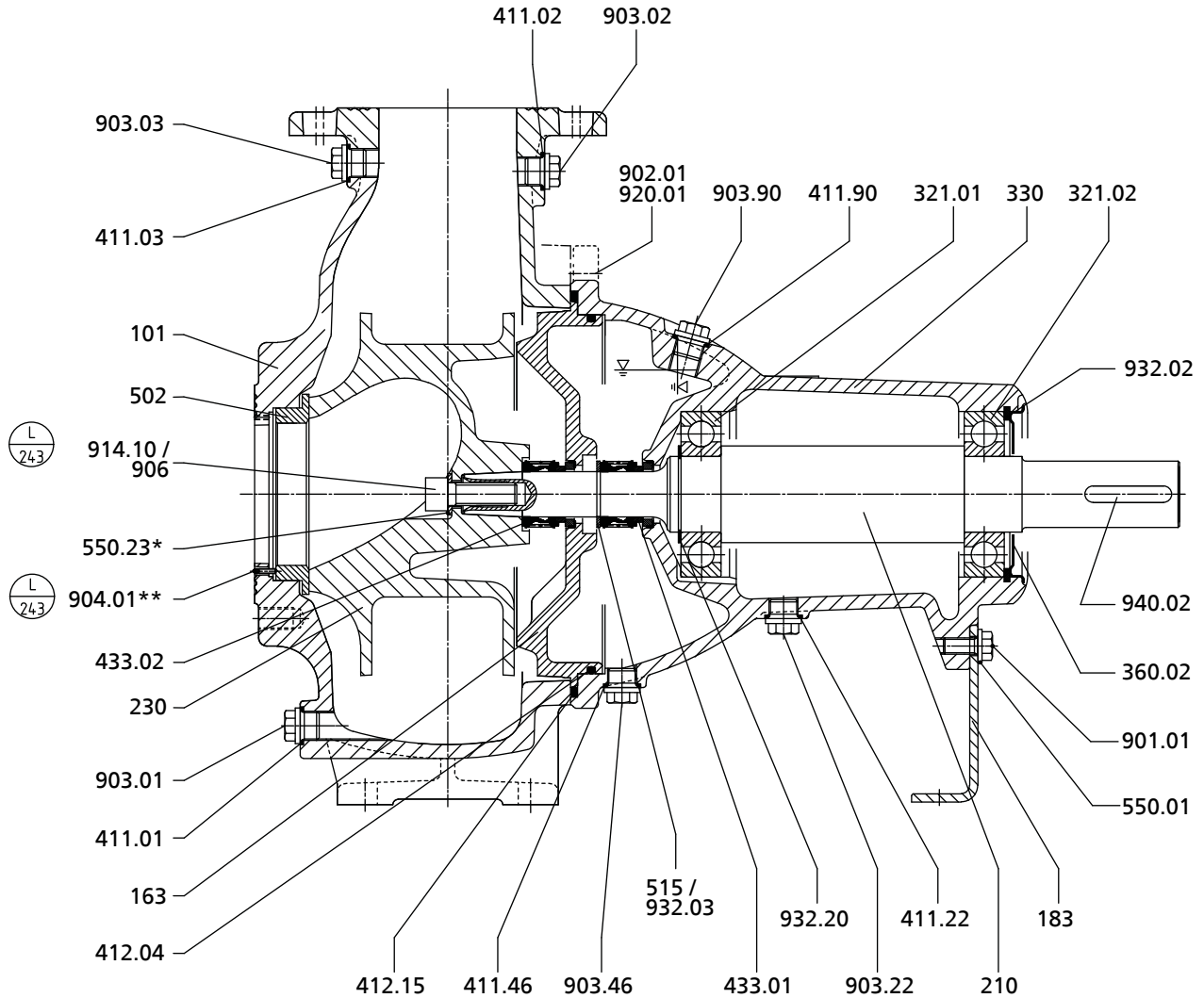


Fig. 47: General assembly drawing of Sewatec - with bearing brackets S01, S02, S03, S04, impeller type E; \* if any, \*\* only for sizes E 100-250, E 100-253, E 100-317, E 150-317, K 100-253, K 100-254, K 100-316

Table 30: List of components

Part No.	Description	Part No.	Description
101	Pump casing	502	Casing wear ring
135	Wear plate	515	Locking ring
163	Discharge cover	550.01/.04/.23	Disc
164.02	Inspection cover	900.02	Bolt/screw
183	Support foot	901.01	Hexagon head bolt
210	Shaft	902.01	Stud
230	Impeller	903.01/.02/.03/.22/.46/.90	Screw plug
321.01/.02	Radial ball bearing	904.01	Grub screw
330	Bearing bracket	906	Impeller screw
360.02	Bearing cover	914.10/.12/.24	Hexagon socket head cap screw
411.01/.02/.03/.22/.46/.90	Joint ring	920.01/.17	Nut
412.04/.05/.15/.34	O-ring	932.02/.03/.20	Circlip
433.01/.02	Mechanical seal		

2580.815/14-EN

9.3.2 Detail drawings

9.3.2.1 Impeller types

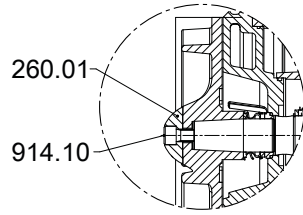


Fig. 48: F impeller

Table 31: List of components

Part No.	Description	Part No.	Description
260.01	Impeller hub cap	914.10	Hexagon socket head cap screw

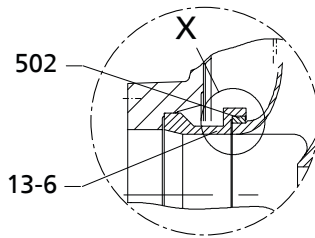


Fig. 49: K impeller

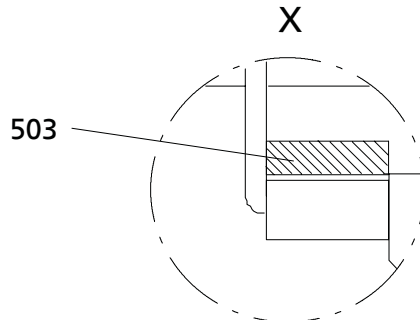


Fig. 50: Detail X: impeller wear ring for K impeller

Table 32: List of components

Part No.	Description	Part No.	Description
13-6 <sup>12)</sup>	Casing insert	502 <sup>13)</sup>	Casing wear ring
503	Impeller wear ring		

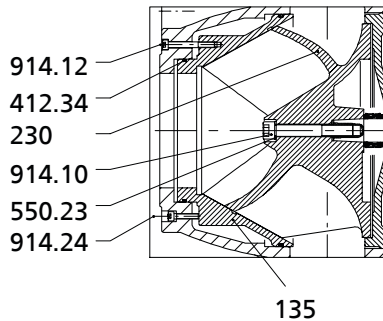


Fig. 51: D impeller (single-vane impeller) and D impeller (multi-vane impeller)

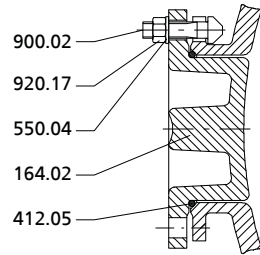
<sup>12</sup> Only for Sewatec 100-401 and 200-400

<sup>13</sup> Not for Sewatec 100-401

**Table 33:** List of components

Part No.	Description	Part No.	Description
230	Impeller	550.23	Disc
412.34	O-ring	914.10/.12/.24	Hexagon socket head cap screw

**9.3.2.2 Inspection hole, bearing brackets S01 to S04**



**Fig. 52:** Inspection hole, bearing brackets S01 to S04

**Table 34:** List of components

Part No.	Description	Part No.	Description
164.02	Inspection cover	900.02	Bolt/screw
412.05	O-ring	920.17	Nut
550.04	Disc		

### 9.3.3 Sectional drawings of the mechanical seal

#### 9.3.3.1 Drive-end mechanical seal

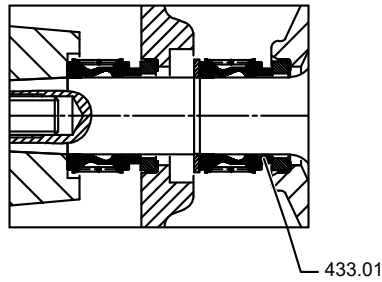


Fig. 53: Drive-end mechanical seal

Table 35: List of components

Part No.	Description
433.01	Mechanical seal

#### 9.3.3.2 Pump-end mechanical seal

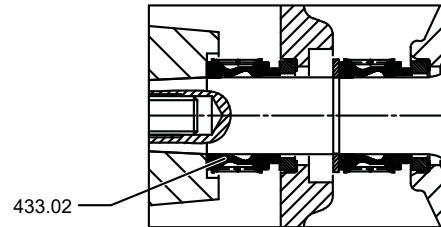


Fig. 54: Pump-end mechanical seal

Table 36: List of components

Part No.	Description
433.02	Mechanical seal

9.3.3.3 Cartridge seal C022/025M1-4STQ

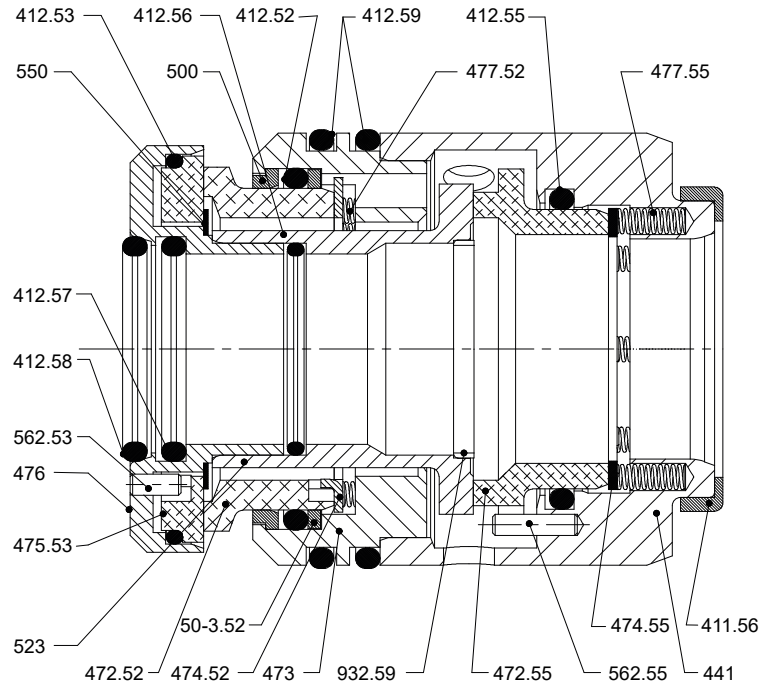


Fig. 55: Sectional drawing

Table 37: List of components

Part No.	Description	Part No.	Description
411.56	Joint ring	487	Mating ring carrier
412.52/.53/.55/.56/.57/.58/.59	O-ring	50-3.52	Backing ring
441	Shaft seal housing	500	Ring
472.53/.55	Primary ring	550	Disc
473	Primary ring carrier	562.52/.55	Parallel pin
474.53/.55	Thrust ring	904.53	Grub screw
475.52	Mating ring	914.52	Hexagon socket head cap screw
476	Mating ring carrier	932.52/.53/.59	Circlip
477.53/.55	Spring for mechanical seal	940	Key

9.3.3.4 Cartridge seal C033/055M1-4STQ

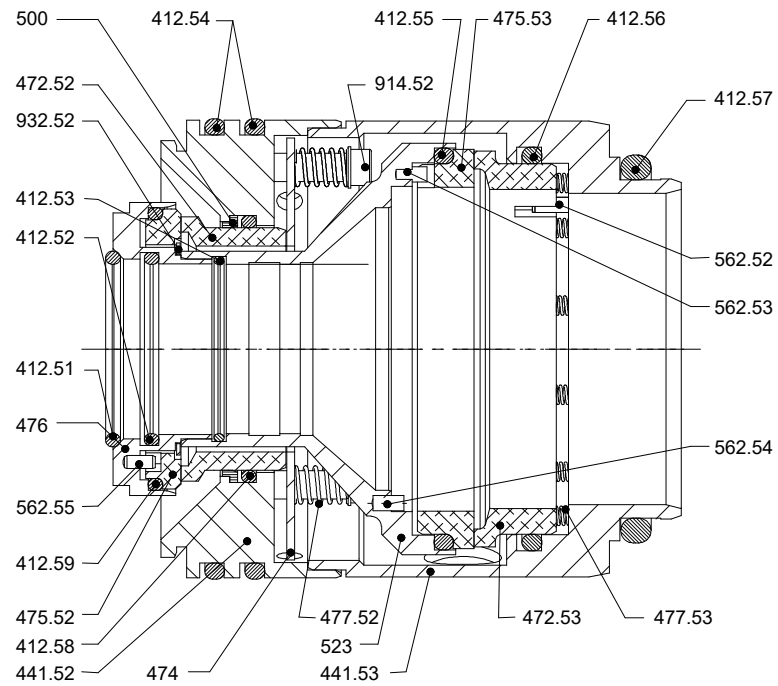


Fig. 56: Sectional drawing

Table 38: List of components

Part No.	Description	Part No.	Description
412.51/.52/.53/.54/.55/.56/.57/.58/.59	O-ring	477.52/.53	Spring for mechanical seal
441.52/.53	Shaft seal housing	500	Ring
472.52/.53	Primary ring	523	Shaft sleeve
474	Thrust ring	562.52/.53/.54/.55	Parallel pin
475.52/.53	Mating ring	914.52	Hexagon socket head cap screw
476	Mating ring carrier	932.52	Circlip

9.3.4 Exploded view: Sewatec with bearing brackets S01, S02, S03, S04

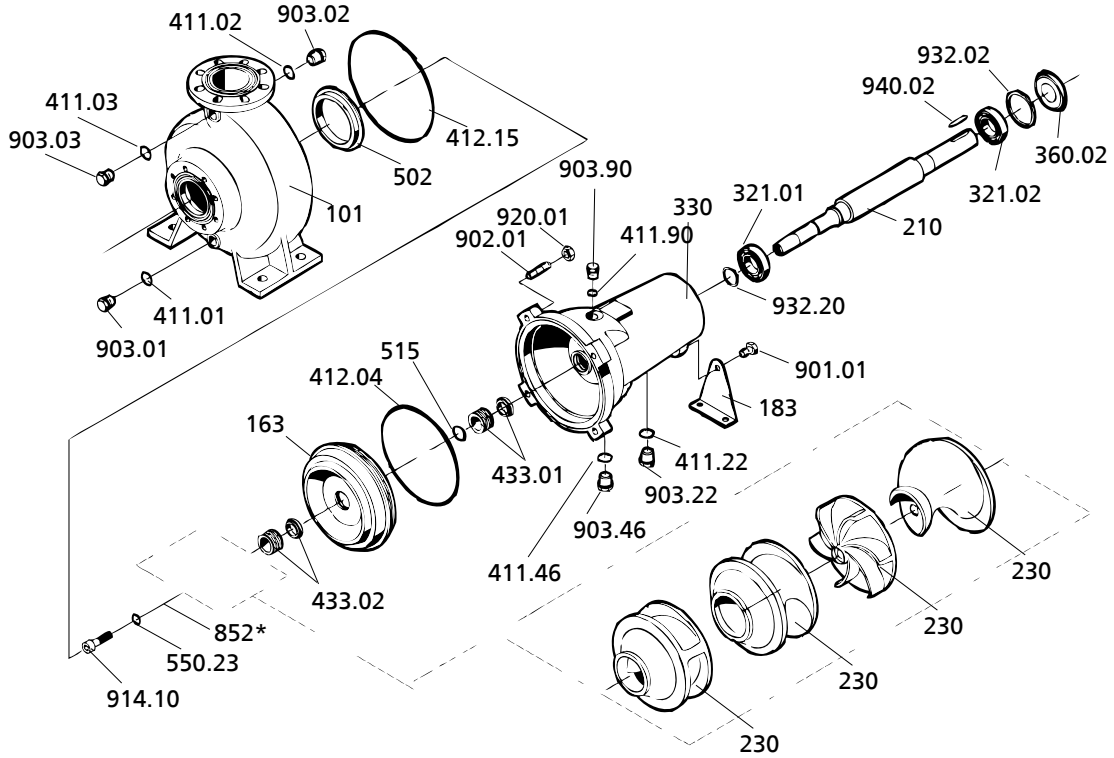


Fig. 57: Exploded view of the pump; \* For Sewatec D 150-251 a screwed coupling (852) is used in this position.

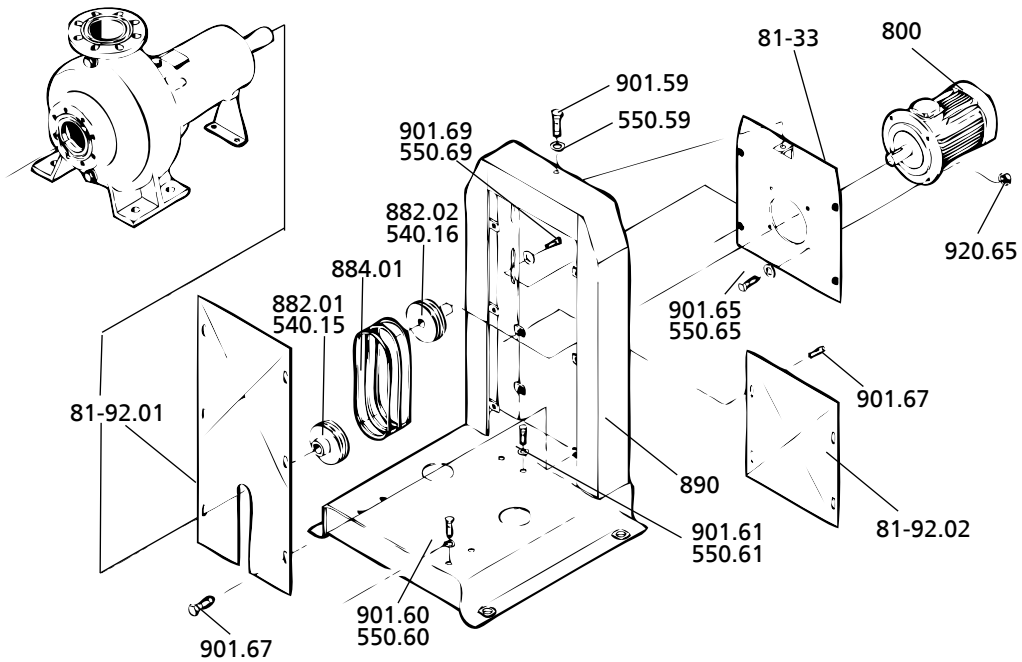


Fig. 58: Exploded view of the belt drive

Table 39: List of components

Part No.	Description	Part No.	Description
81-33	Metal sheet	540.15/.16	Bush
81-92.01/.02	Cover plate	550.23/.59/.60/.61/.65/.69	Disc
101	Pump casing	800	Motor
163	Discharge cover	852 <sup>14)</sup>	Screwed coupling

<sup>14</sup> For Sewatec D150-251 only

Part No.	Description	Part No.	Description
183	Support foot	882.01/02	V-belt pulley
210	Shaft	884.01	V-belt
230	Impeller	890	Baseplate
321.01/02	Radial ball bearing	901.01/.59/.60/.61/.65/.67/.69	Hexagon head bolt
330	Bearing bracket	902.01	Stud
360.02	Bearing cover	903.01/.02/.03/.22/.46/.90	Screw plug
411.01/.02/.03/.22/.46/.90	Joint ring	914.10	Hexagon socket head cap screw
412.04/.15	O-ring	920.01/.65	Nut
433.01/02	Mechanical seal	932.02/.20	Circlip
502	Casing wear ring	940.02	Key
515	Locking ring		



## 10 EU Declaration of Conformity

Manufacturer: **KSB SE & Co. KGaA**  
**Johann-Klein-Straße 9**  
**67227 Frankenthal (Germany)**

The manufacturer herewith declares that the product:

### Sewabloc, Sewatec, Sewatec SPN

KSB order number: .....

- is in conformity with the provisions of the following directives / regulations as amended from time to time:
  - Pump (set): 2006/42/EC Machinery Directive

The manufacturer also declares that

- the following harmonised international standards<sup>15)</sup> have been applied:
  - ISO 12100
  - EN 809

Person authorised to compile the technical file:

Name  
Function  
Address (company)  
Address (street, No.)  
Address (post or ZIP code, city) (country)

The EU Declaration of Conformity was issued in/on:

Place, date

.....<sup>16)</sup>.....

Name  
Function  
Company  
Address

---

<sup>15)</sup> Apart from the standards listed here referring to the Machinery Directive, further standards are observed for explosion-proof versions (ATEX Directive) as applicable and are listed in the legally binding EU Declaration of Conformity.

<sup>16)</sup> A signed, legally binding EU Declaration of Conformity is supplied with the product.

## 11 Certificate of Decontamination

Type: .....

Order number /  
Order item number<sup>17)</sup>: .....

Delivery date: .....

Application: .....

Fluid handled<sup>17)</sup>: .....

Please tick where applicable<sup>17)</sup>:




Corrosive




Oxidising




Flammable




Explosive




Hazardous to health




Seriously hazardous to health




Toxic




Radioactive




Bio-hazardous




Safe

Reason for return<sup>17)</sup>: .....

Comments: .....

The product / accessories have been carefully drained, cleaned and decontaminated inside and outside prior to dispatch / placing at your disposal.

We herewith declare that this product is free from hazardous chemicals and biological and radioactive substances.

For mag-drive pumps, the inner rotor unit (impeller, casing cover, bearing ring carrier, plain bearing, inner rotor) has been removed from the pump and cleaned. In cases of containment shroud leakage, the outer rotor, bearing bracket lantern, leakage barrier and bearing bracket or intermediate piece have also been cleaned.

For canned motor pumps, the rotor and plain bearing have been removed from the pump for cleaning. In cases of leakage at the stator can, the stator space has been examined for fluid leakage; if fluid handled has penetrated the stator space, it has been removed.

- No special safety precautions are required for further handling.
- The following safety precautions are required for flushing fluids, fluid residues and disposal:

.....  
.....

We confirm that the above data and information are correct and complete and that dispatch is effected in accordance with the relevant legal provisions.

.....  
Place, date and signature

.....  
Address

.....  
Company stamp

<sup>17</sup> Required field

## Index

### A

Applications 9

### B

Bearings 17

### C

Certificate of Decontamination 90

Commissioning 38

Coupling alignment 30, 31

### D

Design 17

Designation 17

Direction of rotation 35

Dismantling 50

Disposal 15

### E

Event of damage 7

Ordering spare parts 75

Explosion protection 12, 20, 29, 33, 35, 38, 39, 44, 45, 46, 47

### F

Faults

Causes and remedies 77

Fluid handled

Density 41

Frequency of starts 41

### I

Impeller type 17

Installation

Installation on a foundation 21

Installation at site 20

Intended use 9

### K

Key to safety symbols/markings 8

### L

Lubricant

Quantity 49

### M

Maintenance 45

### O

Operating limits 39, 45

Order number 7

Other applicable documents 7

### P

Partly completed machinery 7

Permissible forces and moments at the pump nozzles 24, 25, 27

Piping 23

Preservation 14

Priming and venting 36

Product description 16

### R

Reassembly 50, 60

Return to supplier 15

Returning to service 42

### S

Safety 9

Safety awareness 11

Scope of supply 19

Shaft seal 17

Spare part

Ordering spare parts 75

Spare parts stock 76

Storage 14

### T

Tightening torques 75

Transport 13

### W

Warnings 8

Warranty claims 7







**KSB SE & Co. KGaA**

Johann-Klein-Straße 9 • 67227 Frankenthal (Germany)

Tel. +49 6233 86-0

[www.ksb.com](http://www.ksb.com)

2580.815/14-EN (01104287)